

# Creation of a Robotic System for Weed Management in Greenhouse Cucumbers

## Abstract

The increasing demand of the rapidly growing population of the world involves compact cultivation. This requires use of greenhouse for food production. Growth of weeds in the environment is a problem for the production. There are many solutions for the problem. Application of robots can be a useful and economic choice. In this study, a purely mechanical machine has been devised for weed control in greenhouse for the first time. It moves on a monorail along the greenhouse to destroy the weeds. The machine stops in the distance between the two main plant rows (cucumber) and its arm goes into the gap to cut the weeds by rotating its blades. This is continued repeatedly. The cutting is by the rotational speed of the blade. Variable-speed motions of the blade were at 3500, 2500 and 1500 rpm for 3 types of moulinex, triangular, and circular blades. The movement speed of the arm was 10 and 30 rpm and the forward movement speed of the machine were 30, 40, 50, 60, 80 and 120 rpm. The results showed that different types of blades, blade speeds and engine speed affect significantly ( $p < 0.05$ ) the percentage of weeds being cut. The interactions of these factors have no significant effect on percentage; the average percentages by the blades have significant differences with each other. Although none of the effects of combination of ANOVA were significant, the comparison of the mean showed that if the blade rotational speed was low, the blade type would have a significant effect on the number of cut weeds. As blade speed increases, their efficiencies were not significantly different. Type of the blades used in the speed of 10 rpm of the engine arm had a significant effect on the cut weed percentage. It can be concluded that the comparison of the interactions between the three different types of blades, blade speed and the movement speed of the arm motor demonstrated that the largest percentage of cut weeds occurred when we use Moulinex blades with 3500 rpm and 10-rpm of engine arm.

**Keywords:** greenhouse, weed control robot, weeds, cucumber

## Introduction

Use of natural resources has been changed in the world and extensive agriculture is replaced by compact cultivation. The demand for off-season production of fruits and vegetables and other agricultural products require controlled environmental conditions. Thus, The Greenhouse technology can be a good choice. Using greenhouse has many advantages including off-season production, efficient use of equipment, increases in productivity of resources and ultimately improvement in profitability of products against factors such as high temperature, strong winds, heavy rains, devastating storms, pests and diseases. Weeds like flairs, wheat, corn, and other weeds often grow in greenhouses resulting in lost production of the main plants. Since the conditions for growing cucumber in greenhouse is in a way that other plants can grow in the best way, this condition is provided for the weeds to grow faster than the original plant. Up to now many methods and ways have been done to prevent the growth of weeds. These are including disinfection of soils either naturally or chemically, destroying weed seeds by heating the environment, use of herbicides. Most of the farmers tend to use the maximum available space and the typical instruments and the machines used for removing weeds could not be used. It is very costly to employ workers to remove the weeds.

Automation of trimming and forwarding with simultaneous localization and mapping techniques will change the industry in the future (Billingsley et al. 2007). It is necessary to select control methods properly to control weeds effectively. Available time, labor, equipment, costs, and types of weeds and the areas infested need to be considered when planning a weed control program. Many alien plant introductions may be benign for years or decades before suddenly exploding into a serious weed pest method (Baskin, Y. 1996). Weed bio control is the suppression of weeds by insects and microorganisms that feed on the target plants or otherwise parasitize them. Success in the method is not assured., because bio control is species-specific and there are a couple of hundred serious weed species and only limited resources to do the exploratory, safety, and efficacy research, bio control has to focus only on a few of the most serious weeds (Baskin, Y. 1996). Cultural control includes those management practices that modify the agro ecosystem to make the pasture, crop, or forest ecosystem resistant to weed establishment (Smith, et al. 1986) integrating sheep or goats to browse brush species and fowl to graze herbs and grasses (Popay and Field 1996). Use of invertebrates or microbes is a specific weed management tactic (Arsalanbod et al. 2013). Prior to the development of modern herbicides, ranch and forest managers relied mainly on mechanical methods of weed control, such as grubbing, bulldozing, dragging, cabling, and mowing. Compared to mechanical weed control methods, herbicides provide greater efficacy at lower cost. Herbicidal weed control results in greater grass production in pastures than does clipping of weeds (Baumann et al. 1991). Technology plays an essential role in this adjustment process (González et al. 2009). The prevention of musculoskeletal disorders has motivated the replacement of human labour by automatons (Van Henten et al 2005).

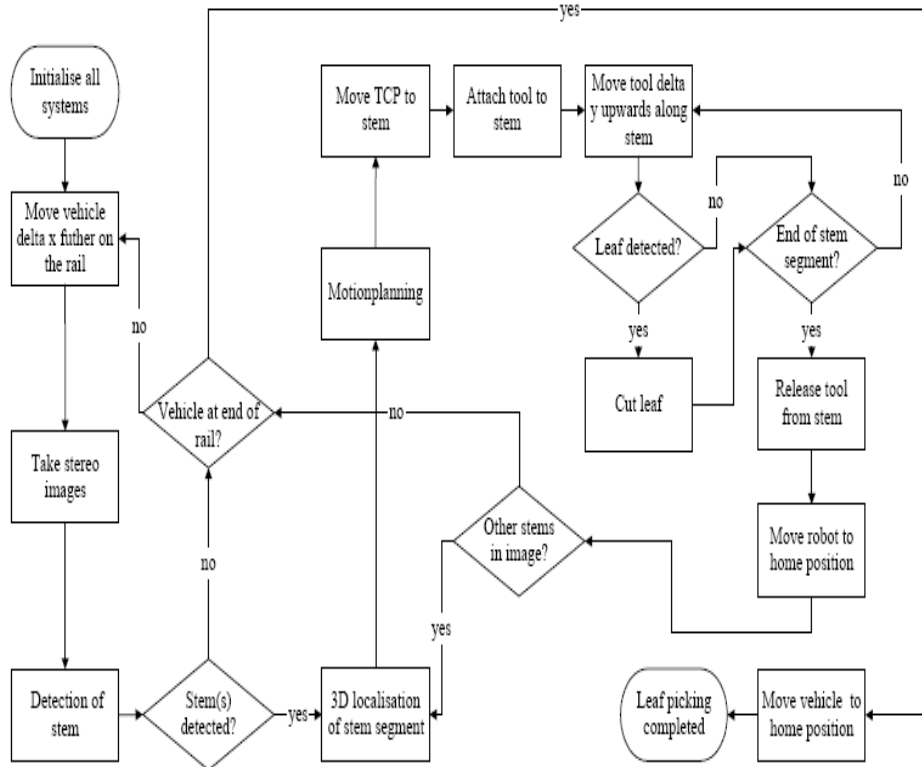
The main application of robots in the commercial sector has been concerned with the substitution of manual human labour by robots or mechanized systems to make the work more time efficient, accurate, uniform and less costly (Sezen, 2003; Hopkins, 2000; Giacomelli and Ting, 1995; Van Henten et.al., 2003; Pilarski, 2002). Producers believe that automation is a viable and sometimes necessary (Giacomelli and Ting 1995) method to ensure maximum profits with minimum costs (Hopkins 2000). Studying on harvesting robot tomato was started in Japan (Monta 2000). From then on robotic technology has been used worldwide for many biological materials (Mohammadi

Monavar et al 2013). Development of an autonomous weeding machine requires a vision system capable of detecting and locating the position of the crop. It is important for the vision system to be able to recognize the accurate position of the crop stem to be protected during weeding (Kiani and Jafari 2012). Pe´rez et al. (2000) developed a near-ground image capturing and processing technique to detect broad-leaved weeds in cereal crops under actual field conditions. The proposed method used color information to discriminate between vegetation and background, whilst shape analysis techniques were applied to distinguish between crop and weeds. Shape features of the radish plant and weed were investigated by Cho et al. (2002). They proposed a machine vision system using a charge coupled device camera for the weed detection in a radish farm. The success rate of recognition was 92% for radish and 98% for weeds (Cho et al. 2002). Astrand and Baerveldt (2003) used some combinations of color and shape features for sugar beet weed segmentation. Color features could solely have up to 92% success rate in classification. This rate increased to 96% by adding two shape features. Jafari et al. (2006) extracted the actual relations between the three main color components R, G and B which constitute weeds and sugar beet color classes by means of discriminant analysis. Different classification success rates ranging from 77% to 98% were gained. Pan et al. (2007) studied the segmentation of weeds and soybean seedlings by their 3CCD images in the field. Texture features of weed species have been applied for distinguishing weed species by Meyer et al. (1998). Grass and broadleaf classification had the accuracies of 93% and 85%, respectively. Polder et al. (2007) used textural image analysis to detect weeds in grass. Gabor wavelet features of NIR images of apples were extracted for quality inspection and used as input to kernel PCA (Zhu et al. 2007). Kernel PCA first maps the nonlinear features to linear space and then PCA is applied to separate the image Gabor wavelet (5 scales and 8 orientations) combined with kernel PCA had the highest recognition rate (90.5%). Recent advances in robotics enable the application of mobile robots for greenhouse tasks which can reduce operator's fatigue and workload, improving the efficiency and operational safety. Manipulator robots have been successfully tested, these robots usually being controlled by vision systems (Sandini et al., 1990; Dario et al., 1994; Kondo and Ting, 1998).

Spray equipment has been developed with vertical spray booms that increase the deposition in the canopy (Langenakens et al 2002, Nuyttens et al 2004, Julián Sánchez-Hermosilla et al 2011). Some of these alternatives are self-propelled vehicles such as Fumimatic® (IDM S.L, Almería, Spain) and Tizona (Carretillas Amate S.L., Almería, Spain), or autonomous vehicles such as Fitorobot (Universidad de Almería, Cadia S.L., Almería, Spain), designed specifically to move without difficulty over loose soils and in spaces with a large number of obstacles (Sánchez et al 2010). These vehicles rely on (inductive) sensors to follow metal pipes buried in the soil; few projects have addressed the navigation problem of vehicles in greenhouses operating completely autonomously [González et al 2009, Mandow et al 1996, and Subramanian et al 2005]. The main challenge of these systems is that localization approaches needed for feeding the closed-loop controllers would lead to inaccurate measurements after a few steps fail for long trajectories (Borenstein et al 1996). A stereovision system along with an image processing algorithm was used to recognize the weeds and also to estimate their location in the field.

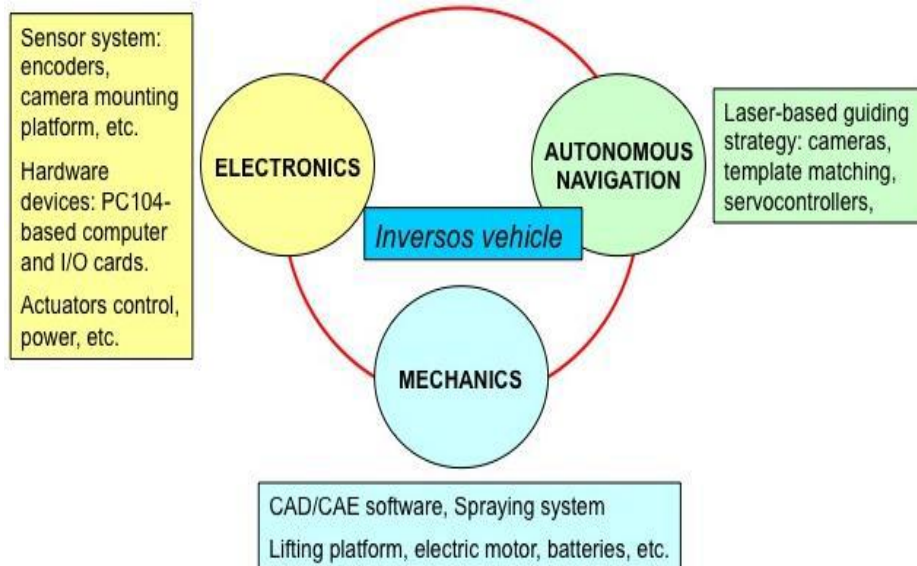
In order to apply chemical directly to the weed's vascular tissue, the direct chemical application end effector was developed. This direct chemical application was performed by cutting the weed's stem and wiping chemical on its cut surface. Lamm et al (2002) conducted a research to develop a proto-type weed control robot that could spray weeds in cotton plants in the seed line. Lee et al (1999) developed a real-time intelligent weed control system for selective herbicide

application to in-row weeds using machine vision and chemical application. Van Henten and et al, (2005) have studied an Autonomous Robot for De-leafing Cucumber Plants Grown in a High-wire cultivation system. The paper presents an autonomous robot for removing the leaves from cucumber plants grown in a high-wire cultivation system. Really van Henten and et al, (2005) describes a functional model and field test of an autonomous robot for de-leafing cucumber plants grown in a high-wire cultivation system. (Figure 1)



**Figure 1: Task sequence during leaf picking in a whole path: 3D, three dimensional; TCP, tool center point**

Artificial neural networks have also been used by many researchers to discriminate weeds (Burks et al., 2005; Granito et al., 2005) with machine vision. (Figure 2)



**Figure 2: Mechatronic paradigm followed in the research (Hermosilla et al 2013)**

Belforte et al. (2006) presents a fixed-position robot. It is interfaced to a standard belt-conveyor displacement system that provides the robot with pallets containing the crops. Ollero et al. (1994), Mandow et al. (1996), and Martinez et al. (2005) describe an autonomous vehicle (Aurora) for spraying purposes. Singh et al. (2004) and Subramanian et al. (2005) also describe a mini-robot to perform spraying activities based on fuzzy logic. The sensorial system uses vision and ladar (laser radar) sensors.

The review of these researches indicates that there is not much research on control or elimination of weeds in a cucumber greenhouse and there is no research for a robotic weed control in a cucumber greenhouse. Various researchers have conducted research regarding general weed control and elimination in external (outdoor) environments. In addition, these researches have been conducted only for a few specific plants. Most of the research in areas of robotic weed control is conducted before the plant growth or in some cases where the main plant is 20 – 30 cm in height. Thus, this research can only serve as a useful guide to help us conduct this research regarding robotic weed control and elimination in an indoor environment and where the main plant can grow even up to 10 meters.

The goal of this study is to design and develop machinery to control weeds in cucumber greenhouses without using chemical materials. The specific objectives of this study are to determine the best type of blades to cut weeds among cultivation rows, best rotation rate for the cutting blades the best moving rate for the guiding arm of the blade, and the best moving rate for the robot.

## **Materials and Methods**

### **Study area**

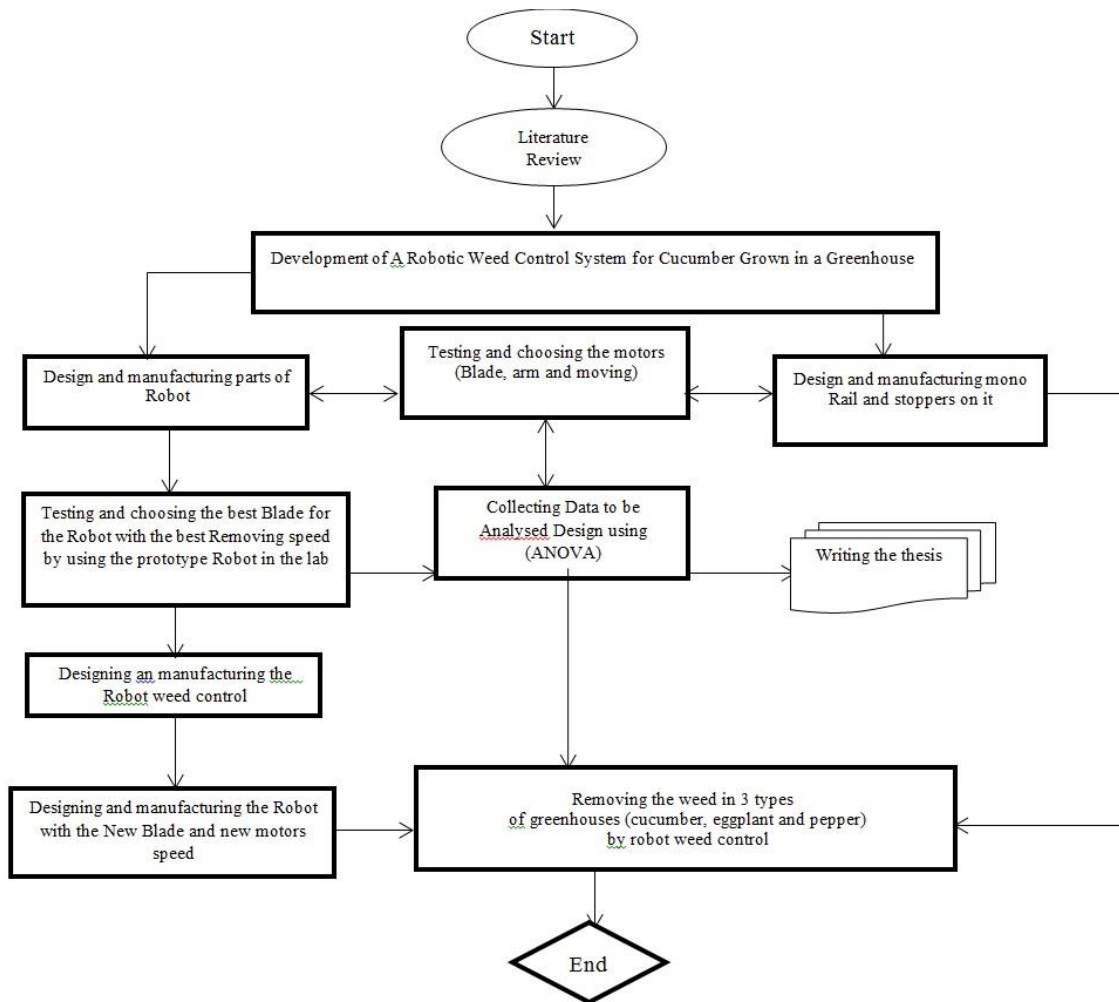
Jiroft is in southern part of Iran with latitude/longitude 67,028, 28 North and 73694, 57 East with an altitude of 690 meters above the sea level and average annual rainfall of 87 mm and a mean annual temperature of -2 to +48 ° C. Jiroft is an area of about 7- thousand-year background with sandy loam soil and hot and dry weather. In the summer months of July and August, the temperature sometimes reaches above 50 ° C but, in winter, the weather is temperate. More

specifically, the temperature is between  $10^{\circ}\text{C}$  to  $25^{\circ}\text{C}$  during the day and  $2^{\circ}\text{C}$  to  $10^{\circ}\text{C}$  at night in the winter. And also because of the fertile soil and sufficient water resources, farmers have the opportunity to cultivate in the cold season (winter) and sell their products to other parts of Iran and neighboring countries. Because of the temperate weather for about 8 months of the year (from October to April), there is no need for heaters in greenhouses, which leads to low production costs, thereby encouraging landowners to construct greenhouses.

Currently there are over two thousand five hundred hectares of greenhouses in the area and surrounding villages. Jiroft is not only one of the greenhouse regions in Iran but also in the Middle East. There are about 5 thousand hectares of small tunnel temporary greenhouses that are gathered outside the growing season and again are constructed at the beginning of the next season.

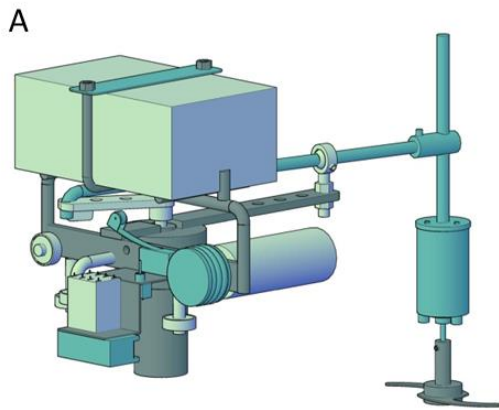
## **Methods**

All the tests in this research have been conducted in two hectares of greenhouse and the other greenhouses in Jiroft. During the growing period, weeds use a large part of water and food and removing them takes time and is costly. The new design was based on a double track (like trains) structure that moves between planted rows. It has a toxin tank, camera, laptop stations and six engines and Sprayer nozzles. It is supplied by a 12-volt car battery. Initially, the program was designed to identify weed in a way that its picture in different situations were taken. When the device moves in front of each row, the eye of the system regularly send a picture to the device. It would compare the taken photos with the database in the memory through the Matlab software. If the image matched with any of the photos in the database of the laptop, an order would be sent to the poison spraying device to sprayed nozzles. But after making the hardware of the system, there was a big problem programing the system and the machine did not work well. The problem was that when a weed had a small change in the shape, size, or leaf size, the system could not detect it. We need to have millions of pictures of different positions of the plant stored in the database laptop which was not practical. Then, it was determined to act the contrary. It means that the system had to identify the main plant, and everything else was accepted as weed. To do this, two methods were done, first through the thick stems and plant shape and the second by the difference in the color of the main plant and weed. In the first method, in the early stages of plant growth, plant size and shape are very close to the weeds. Thus, the system had frequent mistakes and might make damage to the main plant. Secondly, because diversity was high in weeds and the color in some were very close to the main plant, and also during the growing season the color of the plant was changing, the system was making mistake. Because the system needs to be specialized, complex and expensive, it distanced our target that was a practical simple and affordable device. Experimental procedure of this research is conducted in three stages of designing, assembling, and testing the system. (Figure 3)

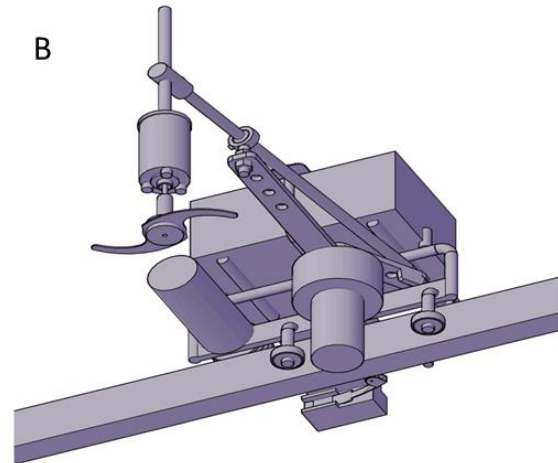


**Figure 3: Flowchart of the study**

**Design of main components of the robot weed control:** The Auto CAD software 2011 version 18.1 was used to design the robot. The robot was attached to the monorail. The implement consists of major components of monorail, the main chassis, ball- bearings, wheels, arms, motors, blades, micro switches, relay, battery, and adjusting mechanism. (Figure 4)



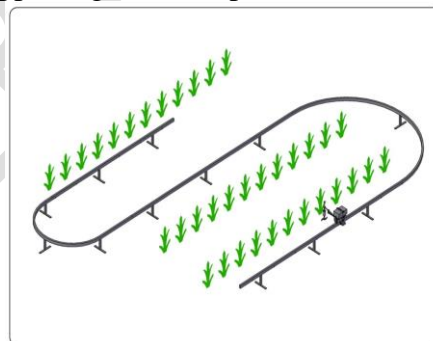
**schematic diagram of the robot  
weed control designed side view**



**schematic diagram of the robot  
weed control designed down view**

**Figure 4: the main components of the robot**

The first point in design of this device was movement method in the greenhouse. We designed a Monorail with two main tasks to move all over inside the greenhouse (Figure 5) and to have stoppers to hold the machine in proper positions. According to robot design and higher height of main plants rows compared to greenhouse level, the rail should be placed above the ground. There are some appendages with 40 cm distance installed on the large 6 cm side along the rail. When the robot reaches each appendage, it stops. After completion of device arms' performance, it restarts to move to the next appendage and the process will be repeated. (Figure 5)



**Figure 5: the pattern for installing monorail between rows**

Several factors must be considered in chassis designing. We have to minimize the weight to easily move on the rails with a small engine. Second, the device must have enough strength to keep all the components. Since the chassis is constant and according to monorail designing, the device should traverse a semicircle with a diameter of 1 meter, length of main chassis must be designed so that the device doesn't exit from the rail. After building and testing some chassis in various sizes and moving it on this semicircle, the best size was selected. The main frame is made from an iron band bearing dimensions of 2cm x 18cm x 5mm. In order to hold battery,

bearing bases, micro switches and the min arm, there are some other fragments on main chassis. We've tried to install these fragments in a way that robot gravity center be placed on monorail. There are few holes in the chassis to facilitate the installation of motor, wheels and required electrical fragments.

The machine makes use of 4 ball- bearings. 3 help the machine to grip the rail and facilitate easy movement and 2 are on one side and 3 on the other. It moves on the rail with the wheel installed at the back of the machine powered by a motor. The diameter of the wheel is 4cm and the ideal speed will be determined during the test.

The moveable mechanical arm consists of 3 parts. Chassis, small arm, main arm. The frame is made of an IRON band bearing dimension  $2\text{ cm} \times 20\text{ cm} \times 5\text{ mm}$ . The chassis to the main chassis is welded and non-moving motor driving the robot arm is located on the chassis. The holes on the mechanical arm facilitate the machine to choose the desired distances. The small arm is on the motor. It completes rotation of the blade between the 2 main plants. There are a few holes on it to ensure that we can obtain the desired vertical distance. There is a slot under the small arm in order to avoid any damage to the motor. The small arm is installed to the main arm on one side. A blade is installed to the main arm on the other side. It moves forward and enables the blade to get between the main plants. A shank protector in one of the holes in the chassis arm causes easy movement and the selection of the angle for cutting.

For the robot to function, it needs to have three motors installed on it. Each motor has a different function and specifications. Motor No. 1 enables the machine to move on the mono rail with sufficient speed and power, a motor with a speed of 60 rpm is required. This high speed motor is specifically used because the robot makes a stop every 40 cm. The motor is fixed directly to the wheels in front of the robot (12 VOLT, 0.5 AMP). Motor No. 2 helps the mechanical arms move forward and backwards. It is connected to the small arm and creates a rotary motion. As the small arm is connected to the big arm, it causes the big arm to move. A few speed tests were conducted before a 10 RPM motor was selected (12 VOLT, 0.5 AMP). Motor No. 3 helps the blade to rotate at high speed in order to cut the weeds. A high powered motor of 3500 RPM had to be chosen. The motor is fixed to the chassis and the chassis is installed to the main arm. This chassis can move up and down and we can fix the distance between the blade and the ground level. After conducting a number of tests, we found that a motor with 3500 RPM was best suited for this function (12 VOLT, 0.75 AMP).

The blade is attached to a high speed motor that enables it to cut the weeds at high speeds. Size and weight of blade are important. The device arm, with the blade attached to it, will be extended as it enters the row to cut the weeds. To accomplish this successfully, the blade size must be chosen carefully as the distance between the two plants is about 40 cm. After conducting a number of tests, we found that a blade with 100 mm was best suited for this function. The blade should be constructed of a light weight material as a heavy blade can make the device unstable when the big arm is outstretched (when it goes inside the row). Due to dampness and high humidity in the greenhouse resulting in corrosion, a stainless steel blade needs to be used. After conducting tests, a double stainless steel blade (moulinex) was found to be most suitable. There are two micro switches and one relay installed on the machine. The micro switches along with the electrical equipment are considered to be the brain of the machine. One micro switch is installed near the rail to move the machine.

When the machine reaches the stoppers installed on the rail, the switch instructs the machine to stop. The second isochronous micro switch controls the second motor and regulates the movement of the first motor. At the next stop, this action is repeated again.

A SEALD LEAD ACID 12 volt 7.2-9 Amper battery powers the machine. The battery can provide power to the machine for up to 2 hours. It is the heaviest part of the robot and is installed on the main chassis - just above the rails and wheels of the machine.

Three types of blades are selected, the first is in the blade form moulinex, the second is triangle form, and the third is circular. The best shape was moulinex form according to the greenhouses, workshop and laboratory tests. On the small arm of the machine there are 3 holes and on the chassis of the device there are also 4 holes based on the location of the fulcrum arm machine. The holes change the width of the working machine, so that the device will be able to move and use the holes in each of the 12 transverse distances between the two main plants to cut the weeds. Thus, if the greenhouse owners want to change the distances of planting between the rows, and this device is used for plants including cucumber, it can easily be achieved by placing the arm in another hole to change the working width. The best distance for cultivating cucumber in a row is 40 centimeters. The cutting width of 380 mm is determined. Due to the lack of precision of farmers in observing the exact distance, stem diameter in the late stages of growth tend to grow are non-vertical, so it seems that it is better the cutting blade to go within a centimeter close to main plant. Since the closer distance will cause a damage to the main stem.

### **The Robot Work Principles**

After switching the device on with the bottom, the robot starts moving on the monorail which has railed along the greenhouse from one row to another. When the robot reaches the first stopper on the rail, it strikes the first micro switch and the micro switch's roller passes over it. When the micro switch's roller is just over the stopper, the micro switch orders the first motor responsible for moving the robot on the rail to switch off; this causes the device to stop moving. The same order is given simultaneously to the second motor responsible for moving the arm to work. The second motor is located under the small arm of the robot causing the circular movement of the small arm.

### **Time needed for robot to Move from One stopper to another**

For motor No 1 a typical speed is 60rpm or 0/45 km/h

Diameter of wheel is 4 cm

$4 \times 3.14 = 12.56 =$  Surrounding of wheel, (cm)

$$T = \frac{3.6 \times x}{Vf}$$

Where,

t= time needed for robot to move from one stopper to another (between two continues stopper), (s)

x= Stopper distance, (m);

Vf= forward speed (km/h)

Assuming Vf = 0/45 km/h (the minimum forward speed) and x=40 cm (distance between two continues stopper), then t=3.2s. for passing the robot between two stoppers within a row was considered for the consequent calculations.

To remove the Time Used for One distance within two plants, we used a typical speed is 10rpm or 0/16 rps (s=second) for motor No2, So for 1 rotate=6s,

T=6s= time needed for robot to remove weed (between two continues plant), (s)

## Greenhouse Test

Three types of blades have 3 rotations of 3500, 2500, and 1500 for the best answer (Table 1). The type of a blade with speed of 3500 rpm rotation/min and arm moving speed or the same speed of arm motor and 10rotation/min was achieved. To compare the efficiency between the blades, the rate of waste grass removal was expressed as a percentage. (Table 1)

**Table 1: Types of blades**

Type of blade	Blade A (moulinex)	Blade B (triangle)	Blade C (circular)
Blade rotation	3500RPM	2500RPM	1500 RPM
Arm motor movement speed	RPM10	—	RPM30

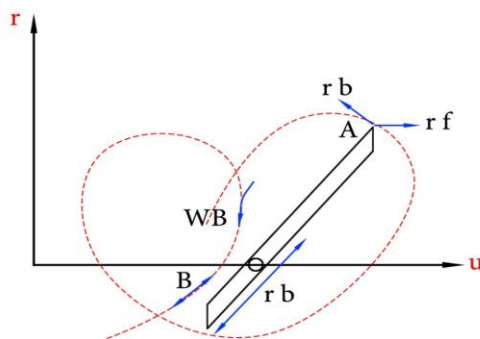
## The Greenhouse Plot Preparation

The weed-removing robot was tested in a two hectare greenhouse, which included four saloons of 5000 m<sup>2</sup>. In this 5000 m<sup>2</sup> hall, about ten thousand seeds were initially planted in pots, and then transferred to the ground with the spaces between two plants being 40 centimeters apart. The device was tested three times in the greenhouse. First, 15 days after the crop was cultivated in the ground and the weeds around them were also 15 days old. The second time when the original plants were 2 months old and they were ready for the product. To remove weeds (10000m<sup>2</sup>) it takes 4 workers during harvesting season every day.

## Results and Discussion

Stickles that their blades are like circular stickles have usually from two to four blades. Following table shows direction of the tip of one blade (A tip) in a two blade stickle. As it is observed, tip of the blade shows a cycloid curve in the ground level (Figure 6).

When blades with the speed of WB go around the circle or axle of stickle and this axle goes on with VF speed, the tips of blades spend a cycloid curve. Speed of the tip of blade is equal to coordinate sum of speed of move and its environmental speed.



**Figure 6: Calculating velocity of rotating blade in stickles (Source: person, 1987)**

$$V_{bf} = v_f + v_b$$

$$(4.1)$$

If  $V_{bf}$  is the total speed of blade than ground surface (m/s) and  $v_f$  is the moving speed of stickle (m/s) and  $v_b$  is the environmental speed of blade tip (m/s) [ $v_b = v_b \cdot WB$ ] and  $r_b$  = radius of blade tip (m) and  $WB$  = circular speed of blade [rad/s].

If consider direction of moving as  $u$ , direction of moving blade than product that is in direction of  $V_{bf}$  and by rotating the blade it changes in each moment and turns. In this state for achieving components of  $u$  and  $v$  speed of blade tip can be written as component of blade speed in direction of moving  $u$ : (person, 1987). (Figure 7)

$$r_u = r_f - U_{bu} = v_f - v_b \sin \theta = r_f - r_b \omega_b \sin(\omega_b t)$$

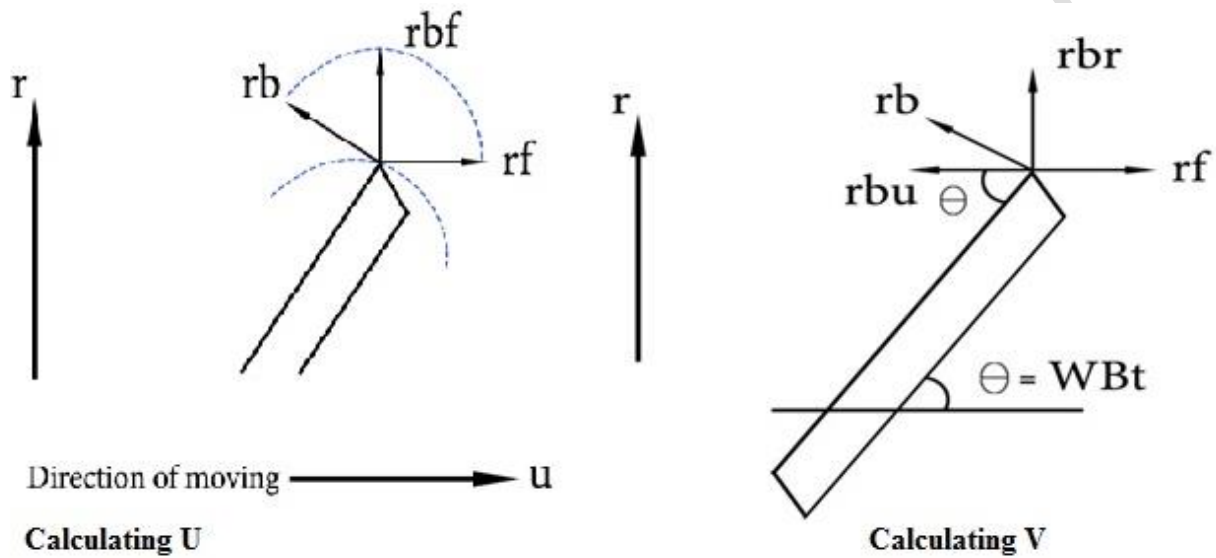


Figure 7: Calculating U (left) and V (right) (Source: person, 1987)

The component of blade tip in direction  $v$  is obtained by:

$$V_v = V_b v = V_b \cos \theta = r_b \omega_b \cos(\omega_b t)$$

$V_u$  and  $U_u$  based on (m/s)- $\theta$  angle between blade and movement direction =  $WBt$

And  $t$  = measured time from point  $\theta = 0$  (s)

Speed of blade tip than ground is obtained by:

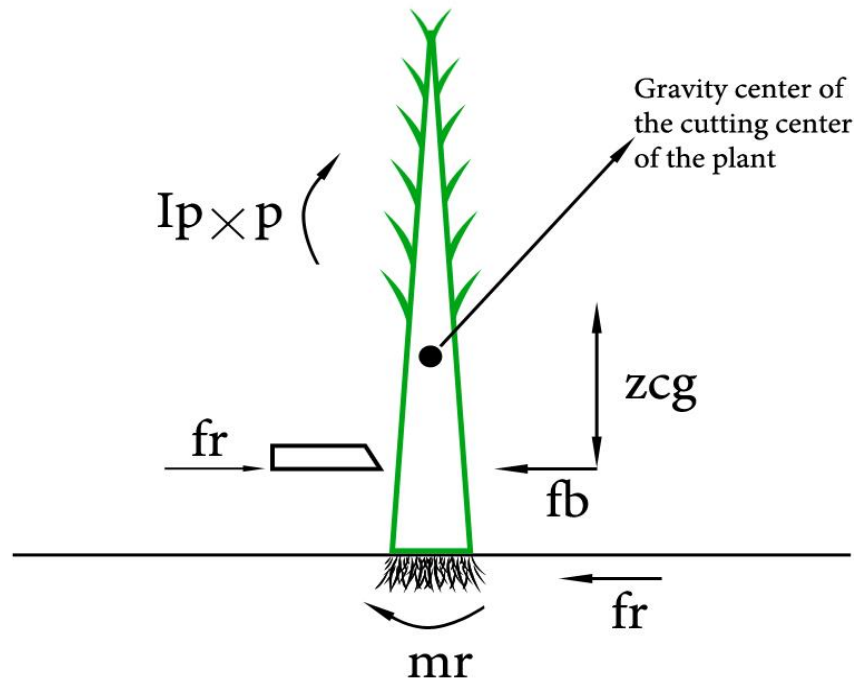
$$|r_{bf}| = \sqrt{|V_r|^2 + |r_u|^2}$$

Then based on features of plant for specifying the lowest velocity blade in the cutting strike is achieved. When strike power is used for cutting stem. There is no anti-blade and only by stick of blade to the stem causes stem to be cut. In the cases when blade nonexistent all support is from the plant itself (anti-blade job), this support is by bending strength of remaining plant in the cutting line and hardness of its torques that a part of plant over the level of cutting line is supplied.

In the Figure (8) forces and torques are represented in the cutting strike to the plant. Plant acts like a pile that one part of it is stricken, soil and root of plant is a force of  $F_b$  and provides torques  $M_r$  that causes the plant to stand straight.  $F_b$  power is the result of sum of impacts of root strength that provides bending strength of stem in the height of cutting point. Gravity center of the cutting center of the plant body in the height and  $Z_c$  from the cutting surface:

In the strike cutting that is shown in the picture to the cut part there is a speed to right and against hour direction and finally a hard and torques power will be formed in the center of the plant; sum of torques than cut gravity center (person, 1987). (Figure 8)

$$IP\alpha p = (Fr - Fb) Zcg$$



**Figure 8: Components of forces (Source: person, 1987)**

Alfa p= Angular momentum of plant (Radian/s<sup>2</sup>)

Fr= cutting power (N)

Fb=bending strength of the plant body (N)

IP= pant geometry hardness torques (Kgm<sup>2</sup>=mPrg<sup>2</sup>)

Mp: weight of the cutting part of the plant (kg)

Rg= radius of geidasion in the cutting part of the plant (m)

$$\alpha p = \frac{ac - acg}{zcg}$$

Ac= speed of plant in the cutting level (m/s<sup>2</sup>)

Acg= speed of plant gravity center (m/s<sup>2</sup>)

Assuming that speed of plant in the cutting level is equal to the speed of blade movement and we can write:

Vk= speed of blade (m/s)

$$ac = \frac{1000r^2k}{ds}$$

Ds= diagonal of stem in the cutting level (mm)

From formulas 1,2, and 3 we conclude that:

$$Vk = \sqrt{ds \frac{(fr - fb)}{1000 \times mp} \left(1 + \frac{z^2 cg}{r^2 g}\right)}$$

It is possible to consider bending strength of areal body equal to final load for bending failure.

$$fb \approx fbu = \frac{I su}{C L}$$

Fbu: final load for bending failure (N)

I (torques of cross section hardness (4 mm))

$C$  = radius distance from stem axle to the most far point that should be situated underneath.

$I/C$  = module of cross section ( $\text{mm}^3$ )

$S_u$  = final buckling  $\text{N}/\text{mm}^2$

$L$  = distance of load center to reliance point (mm)

In the formula  $V_k$ , if values of  $r_g$  and  $z_{cg}$  can be achieved easily, one approximate simple equation can be considered assuming that  $r_g = z_{cg}$ .

This more simple equation shows the impact of key variables that interfere in strike cutting, if bending strength of areal part,  $F_b$  is so great that the entire cutting powers support  $F_x$  the least speed of the blade is zero and cutting is similar to Scissors blade. Decrease in the height of cutting for increasing  $F_b$  and decreasing  $F_s$  by use of one blade, both of them are influential for lowering the speed. The consumption power of plate like reaper; it is more than types of tooth, because not only they carry the grass, but give them great deal of acceleration. Sickle usually is a device connected from two blades or three blades or four blades that are also connected to one motor (Person, 1987).

The way it works is similar to plate like sickle. It differs when blades are connected to the circulating plate. Stably blades are connected to a motor and a specified direction after the motor and before blades release from Klatch to in lower speeds of motor and the time when blades face to the obstacle movement from motor to the blades would be interrupted. For calculating the consumption power, these devices can be written as:

$P_{mt} = (P_{ls} + E_{sc} r_f) w_c$

$P_{mt}$ : general necessary axle power (Kw)

$P_{ls}$ : wasted power for air erosion, plant and transformance machine (Kw/m from cutting length)

$E_{sc}$ : special energy of cutting ( $\text{kd}/\text{m}^2$ )

$W_c$ : length of cutting sickle (m)

The values of NIAE show  $1.5 < P_{ls} < 4 \text{kw}/\text{m}$  for plate and cylindrical sickles. Because  $P_{ls}$  part is mentioned based on length of cutting. For sickles, it is the something about 1.5 to  $2.5 \text{kw}/\text{m}$ . Rate of  $E_{sc}$  from  $1.5 \text{ kd}/\text{m}^2$  keen blade is  $2.1 \text{ Kd}/\text{m}^2$  for a slow blade changes. The ordinary type of these sickles work with strike power (Person, 1987).

### Static analysis

There are four factors in this research including type of blade 1, blade rotation 2, arm motor movement speed 3 and number of weeds 4, and a dependent variable of weeds percentage. There are 3 types of blades A, B and C, blade rotations of 1500, 2500 and 3500, and arm motor movement speed of 10 and 30. The obtained results are brought in Table 4. According to Table 4, not all binary, ternary and quaternary interaction effects are significant. Main effects of T, BR, AMS and NW are significant at (0.05) significance level.

In the table T = type of blade, BR = Blade rotation, AMS = Arm motor movement speed, NW = Number of weeds, SB = shape of blade

According to Tables 2 and 3, BR factor is significant with  $P < 0,05$ . This indicates Blade type A with 67.833 mean and standard error of 3.052. It has the highest effect and Blade type B with 61.388 mean and standard error of 3.083 has the lowest effect on weed percentage. (**Table 2**)

**Table 2: Factors effective on weed percentage and Percentage factors effective on weed**

Changes' origin	mean	Std. error	Changes' origin	mean	Std. error
Blade A	67.833	3.052	R1500	50.39	1.866
Blade B	61.388	3.083	R2500	64.95	1.51
Blade C	64.333	3.388	R3500	78.23	1.71

Blade rotation (BR) factor is significant with  $P < 0.05$  which indicates that 3500 R with 78.23 mean and standard error of 1.71 has the highest effect and 1500 R with 50.39 mean and standard error of 1.866 has the lowest effect.

**Arm motor movement speed (AMS) factor** is significant with  $P < 0.05$  which indicates that speed of 10 with 69.148 mean and standard error of 2.457 has had the highest and speed of 30 with 59.88 mean and standard error of 2.461 has the lowest effect on weed percentage. (Table 3)

**Table 3: Factors effective on weed percentage**

Changes' origin speed	mean	Std. error	Changes' origin	mean	Std. error
10	69.148	2.457	NW	8.203	0.527
30	59.88	2.461			

**Number of weeds (NW) factor** is also significant with  $P < 0.05$  and mean and standard error of this factor are 8.203 and 0.527, respectively.

### Ineffective factors in the 1st stage of analysis with interaction effects

**Two-factor interactions:** Effects of Interaction between Blade type and Blade rotation at 0.05 level is insignificant. Therefore, removing this effect from the model is statistically justified (T×BR Interaction). Effects of Interaction between Blade type and Arm motor movement speed at 0.05 level is insignificant. Therefore, removing this effect from the model is statistically justified (T×AMS Interaction), Effects of Interaction between the Blade type and weed number at 0.05 level is insignificant. Therefore, removing this effect from the model is statistically justified (T×NW Interaction). Effects of Interaction between Blade Rotation and Arm motor movement speed at 0.05 Level is insignificant. Therefore, removing this effect from the model is statistically justified (BR×AMS Interaction). Effects of Interaction between the Blade Rotation and Weed number at 0.05 level is insignificant. Therefore, removing this effect from the model is statistically justified (BR×AMS Interaction). Effects of Interaction between Arm motor movement speed and Number of Weeds at 0.05 Level is insignificant. Therefore, removing this effect from the model is statistically justified (AMS ×NW Interaction).

**Three-factor interactions:** Effects of Interaction between Blade Type and Blade Rotation and Arm motor movement speed at 0.05 Level is insignificant. Therefore, removing this effect from

the model is statistically justified (T×BR×AMS Interaction). Effects of Interaction between the Blade Type and Blade Rotation and Number of weeds at 0.05 level is insignificant. Therefore, removing this effect from the model is statistically justified (T×BR× NW Interaction). Effects of Interaction between Blade Type and Arm motor movement speed and Number of weeds at 0.05 Level is insignificant. Therefore, removing this effect from the model is statistically justified (T× AMS × NW Interaction). Effects of Interaction between Blade Rotation and Arm motor movement speed and Number of weeds at 0.05 Level is insignificant. Therefore, removing this effect from the model is statistically justified (BR × AMS × NW Interaction).

**Four-factor interactions:** Effects of Interaction between the Blade Type and Blade Rotation and Arm motor movement Speed and Number of weeds at 0.05 level is insignificant. Therefore, removing this effect from the model is statistically justified (T×BR × AMS × NW Interaction). According to Table 4, all the interaction effects are removed from the model. Then, variance analysis is done again and effective factor are specified in this stage. (Table 4 and 5)

**Table 4: Effects of T×BR Interaction**

Interaction Types	Changes' origin	Sum of squares	Mean sum of squares	p-value
<b>Two-factor interactions</b>				
T×BR Interaction	T×BR	114.1	57.1	0.1272
T×AMS Interaction	T×AMS	5.4	5.4	0.6493
T×AMS Interaction	T×AMS	5.4	5.4	0.6493
T×NW Interaction	T×NW	1.9	1.9	0.7887
BR×AMS Interaction	BR×AMS	73.6	36.8	0.2560
BR×AMS Interaction	BR×NW	91.5	45.8	0.1872
AMS ×NW Interaction	AMS×NW	0.7	0.7	0.8732
<b>Three-factor interactions</b>				
T×BR×AMS Interaction	T×BR×AMS	16	8	0.7356
T×BR× NW Interaction	T×BR×NW	140.6	70.3	0.08
T× AMS × NW Interaction	T×AMS×NW	21.9	21.9	0.3641
BR × AMS × NW Interaction	BR×AMS×NW	17.6	8.8	0.7138
<b>Four-factor interactions</b>				
T×BR × AMS × NW Interaction	T×BR×AMS×NW	6.6	3.3	0.8809

**Table 5: Variance analysis (ANOVA) for weed percentage in the model without interactions**

Model	Sum of squares	Mean sum of squares	df	F statistic	p-value
T	110.3	110.3	1	4.1848	0.0462
BR	6977.1	3488.6	2	132.4174	0.000
AMS	1157.4	1157.4	1	43.9322	0.000
NW	140.1	140.1	1	5.3179	0.025
Error	1264.6	26.3	48		

**Effective factors in the 2nd stage of analysis without interactions**

According to p-values, all main effects of Blade type, Blade rotation, Arm motor movement speed and number of weeds factors are significant at 0.05 Level. (Table 6 and 7)

Auxiliary test (LSD) was conducted for detection of significant difference between factor levels.

**Table 6: Comparison of significant difference between Blade Type factor's levels**

Blade1	Blade2	Mean differences(I-J)	STD Error	P-value
A	B	6.4444	1.62462	0.000
	C	3.5000	1.62462	0.036
B	A	-6.44444	1.62462	0.000
	C	-2.9444	1.62462	0.076
C	A	-3.5000	1.62462	0.036
	B	2.9444	1.62462	0.076

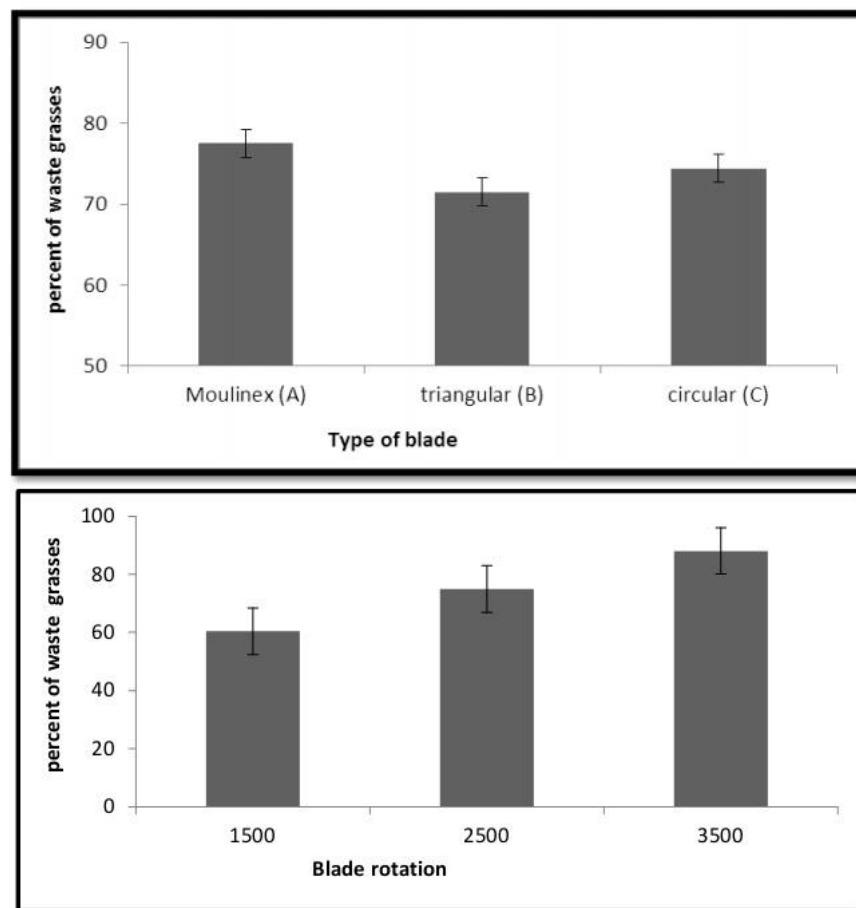
**Table 7: Comparison of significant difference between Blade Type factor's levels**

BR1	BR2	Mean differences (I-J)	STD Error	P-value
1500	2500	-14.5556	1.62462	0.000
	3500	-27.8333	1.62462	0.000
2500	1500	14.5556	1.62462	0.000
	3500	-13.2778	1.62462	0.000
3500	1500	27.8333	1.62462	0.000
	2500	13.2778	1.62462	0.000

According to P-values in table 6, the difference between A and B Blade's mean with P-value which is 0.000 is significant at 0.05 Level. In other words, mean of weeds cut by these two Blade Types are significantly different and according to the Mean differences column it is implied that mean of Weed percentage cut by blade A is larger than mean of Weed percentage cut by blade B. Mean difference between Blades A and C with 0.036 P-value is significant at 0.05 level. It

means that mean of weeds cut by these two Blade Types are significantly different and according to the Mean differences column it is implied that mean of Weed percentage cut by blade A is larger than mean of Weed percentage cut by blade C. The difference between B and C Blade's mean with 0.076 P-value is not significant at 0.05 Level. In other words, mean of weeds cut by these two blade types are not significantly different. In general, mean of weeds cut by Blade B has had the smallest value (61.388) and that by Blade A has had the largest value (67.833).

According to P-value column in table 7, mean difference between Blade Rotation levels are all significant. In other words, the means of weeds cut in 1500 R, 2500R and 3500R are not significantly different. According to mean differences column, it can be inferred that mean of weeds cut in 1500 R has been smaller than those of 2500R and 3500R. As well, mean of weeds cut in 2500 R has been smaller than that of 3500R. Generally, mean of weeds cut in 1500 R has been the smallest (59.39) and that of 3500R has been the largest (78.23). (Figure 9)



**Figure 9: Comparing effects of various Blade types on cut weed's percentage (A), Comparing effects of various Blade Rotation levels on cut weed's percentage (B)**

## Descriptive statistics and graphs for the Variables

Table 8 to 11 and Figures 10 show descriptive statistics and Frequency of the percentage of the Weed for Blade A ,B ,C, BR(1500,2500,3500 rpm), AMS(10,30 rpm) and NW.

**Table 8 : Blade Type descriptive statistics**

<b>T</b>	<b>Blade A</b>	<b>Blade B</b>	<b>Blade C</b>
<b>frequency</b>	18	18	18
<b>mean</b>	67.8333	61.3889	64.3333
<b>median</b>	68.5000	60.0000	69.0000
<b>STD deviation</b>	1.29	13.0841E1	14.3773E1
<b>Skewness</b>	.372	-.007	-.509
<b>kurtosis</b>	-.127	-.519	-.711
<b>Minimum</b>	45.00	38.00	35.00
<b>Maximum</b>	95.00	85.00	84.00

**Table 9 : Descriptive statistics for BR**

<b>BR</b>	<b>R 1500</b>	<b>R 2500</b>	<b>R 3500</b>
<b>frequency</b>	18	18	18
<b>mean</b>	50.3889	64.9444	78.2222
<b>median</b>	52	65.5000	78
<b>STD deviation</b>	7.91974	6.43951	7.28056
<b>Skewness</b>	-0.342	-0.020	0.454
<b>kurtosis</b>	-0.279	-0.826	0.144
<b>Minimum</b>	35	53	66
<b>Maximum</b>	65	77	95

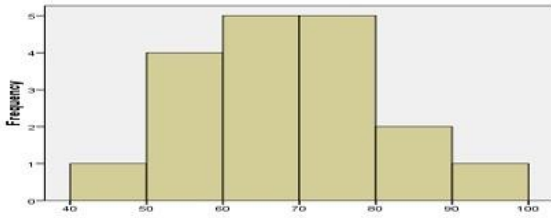
**Table 10 : Descriptive statistics for the Arm motor movement speed**

<b>AMS</b>	<b>Speed 10</b>	<b>Speed 30</b>
<b>frequency</b>	27	27
<b>mean</b>	69.11481	59.8889
<b>median</b>	69	60
<b>STD deviation</b>	1.2769	1.2789
<b>Skewness</b>	0.185	-0.413
<b>kurtosis</b>	-1.084	-0.949
<b>Minimum</b>	46	35
<b>Maximum</b>	95	79

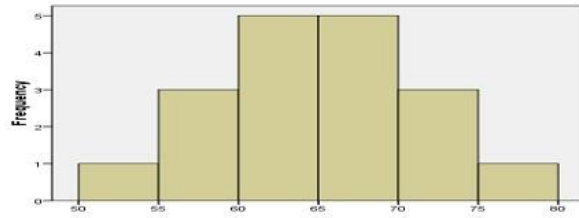
**Table 11 : Descriptive statistics for the number of the weed**

<b>frequency</b>	54
<b>mean</b>	8.2037
<b>median</b>	8
<b>STD deviation</b>	3.87727
<b>Skewness</b>	0.366

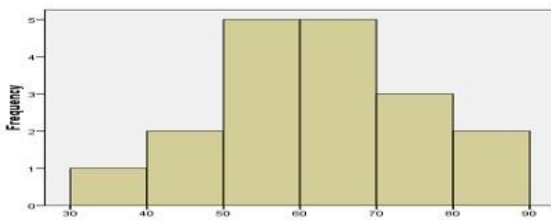
<b>kurtosis</b>	1.343
<b>Minimum</b>	0
<b>Maximum</b>	20



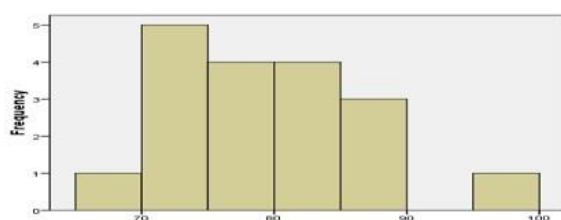
blade A



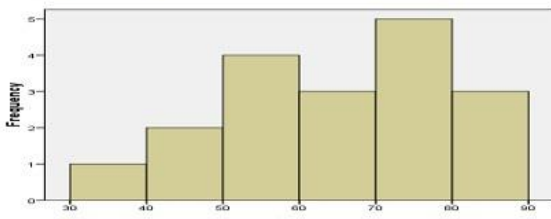
Rotation 2500



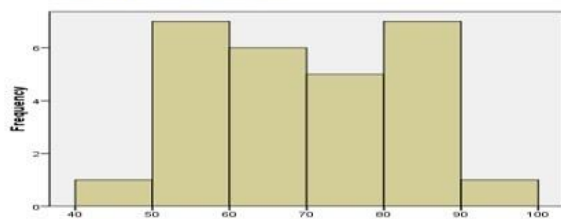
blade B



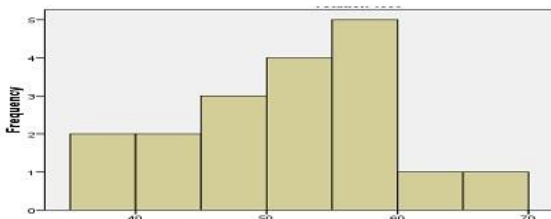
Rotation 3500



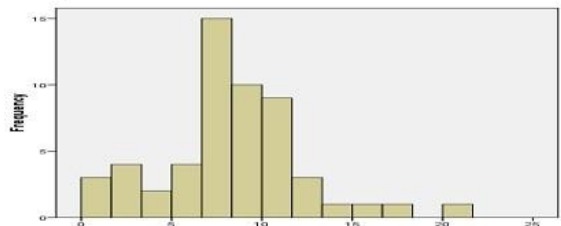
blade C



Speed of Machine Arm 10



Rotation 1550



considerable weed distribution

**Figure 10: descriptive statistics**

The analysis of the interaction of the blade speed and blade type showed that (a) none of the mutual interactions was significant in the variance test. (b) t-test showed that if the rotational speed of the blade was low, the blade type would have a significant effect on the NW cut. (c) The increase in the blades 'rotational speed, the efficiency of the blades did not change significantly. (d) For all the blade types, the highest percentage of the weeds cut was at 3500 rpm. In each motor arm speed, the increasing of the rotational blade speed caused an increase in percentage of weeds cut. In each rotational blade speed, if the motor arm speed increases the percentage of the weeds cut will decrease.

### Computing width of the working machine

The small arm of the machine there are 3 holes and on the chassis of the device based on the location of the fulcrum arm machine also there are 4 holes. Average of issues having at least one shared character in each column of the Duncan test in the possibility level of 5% has no significant difference.

### Computing the different width for the machine

1- If the present holes on the short arm (3 holes) are called  $A_1$ ,  $A_2$ , and  $A_3$  and the chassis holes (4 holes) are called  $B_1$ ,  $B_2$ ,  $B_3$  and  $B_4$ , the following cases arise:

$(A_1-B_1)$ ,  $(A_1-B_2)$ ,  $(A_1-B_3)$ ,  $(A_1-B_4)$

$(A_2-B_1)$ ,  $(A_2-B_2)$ ,  $(A_2-B_3)$ ,  $(A_2-B_4)$

$(A_3-B_1)$ ,  $(A_3-B_2)$ ,  $(A_3-B_3)$ ,  $(A_3-B_4)$

The length of the small arm is 70 mm. (From the junction to the motor arm to the bottom) that rotates around his arm where the arm is connected to the motor. So the short arm rotates round a circle with a diameter of 140 mm or 14 cm. If the distance between the centers of the last hole on the short arm ( $A_1$ ) to the motor shaft of the motor is considered 65 mm, the long arm ( the main) device when using the last hole at the junction of the short arm ( $A_1$ ) rotates round a circle with a diameter of 130 mm or 13 centimeters over it. As the distance between the holes is 20 mm or 2 centimeters, so if the second hole  $A_2$  is used the diameter will be 90 mm or 9 centimeters. If the latest hole ( $A_3$  the nearest hole to the shaft) is used, the circle with a diameter of 50 mm or 5 inches will be traversed.

4- If the arm is placed in the hole  $A_1$  and the main arm in the hole  $B_1$  and the small arm is completely in the vertical position with and the chassis that the base of arm is placed in its holes. A right triangle is created that two sides of it is clear .It is the triangle  $A_1B_1D$  (All measures are in mm units). (Figure 11a)

$A_1D = \text{the radius} = 65 \text{ mm} = a$

$B_1D = 150 \text{ mm} = b$

$$c^2 = a^2 + b^2 \Rightarrow c^2 = (65)^2 + (150)^2 \Rightarrow c^2 = 4225 + 22500 \Rightarrow c^2 = 26725 \Rightarrow c = 163.47 \text{ mm} \approx c = 164 \text{ mm} \Rightarrow A_1B_1 = 164 \text{ mm}$$

Because  $A_1 B_1$  is part of the big arm so the remaining part of the big arm (the main part) will be equal to:

$$350 - 164 = 186 \text{ mm}$$

If the small arm moves a full semicircle the right triangle will change to isosceles triangle with sides of:

$$A_1B_1 = 164 \text{ mm}$$

$$EB_1 = 164 \text{ mm}$$

$$A_1 E = 130 \text{ mm diameter}$$

Both sides  $A_1 B_1$  and  $B_1 E$  are parts of the long arm (main) of the machine. However, as in this case be considered along the arm. (Figure 11b)

Another triangle will be created on the top of the triangle  $A_1B_1E$  called  $B_1FG$ . Calculating the length of  $FG$  the width of the working machine can be created. In this triangle  $B_1G$  equals  $B_1F$  so that it is isosceles triangle and the angles  $\alpha$  and  $\beta$  are equal, as a result, the triangles  $A_1B_1E$  and  $B_1FG$  are similar. The similarity of the two triangles can be written (Figure 11c) as bellow:

$$A_1B_1 = B_1E \Rightarrow 350 - 164 = 186$$

$$\frac{A_1B_1}{B_1G} = \frac{B_1E}{B_1F} = \frac{A_1E}{FG} \Rightarrow \frac{164}{186} = \frac{164}{186} = \frac{130}{FG} \Rightarrow FG = \frac{130 \times 186}{164} = 147.43 \Rightarrow FG \approx 147$$

Since the beginning of the long arm is placed right in the axis of the cutting blade, so two radiuses of the blades should be added to the both sides of FG side of the triangle then cutting width of the machine in using the holes ( $A_1 - B_1$ ) is achieved.

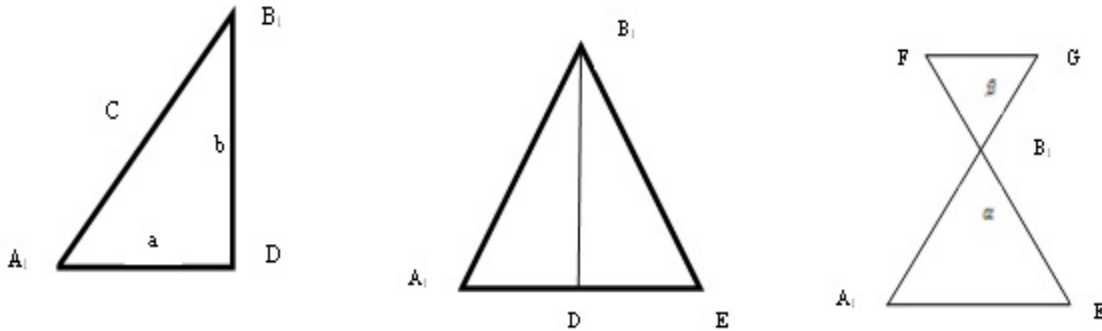


Figure 11: the different width for the machine

**So:**

The width of cutting  $FG = 147 = FG + r + r \Rightarrow 147 + 50 + 50 \Rightarrow$

The width of the machine in position 1 ( $A_1B_1$ ) = 247mm.

In the same way and using different holes can be calculated as 11 other states. In the following calculation to determine the width of the machine in different modes is presented.

The width of the machine in position 2 ( $A_1B_2$ )

$$A_1D = r = 65\text{mm} = a$$

$$B_1D = 130\text{ mm} = b \Rightarrow c^2 = a^2 + b^2 \Rightarrow c^2 = (65)^2 + (130)^2 \Rightarrow c^2 = 4225 + 16900$$

$$c^2 = 21125 \Rightarrow c = 145.34 \Rightarrow c \approx 145\text{ mm}$$

$$350 - 145 = 205$$

$$A_1B_2 = 145\text{mm}$$

$$EB_2 = 145$$

$$B_2G = 155$$

$$B_2F = 155$$

$$A_1E = 133$$

$$\frac{A_1B_2}{B_2G} = \frac{EB_2}{B_2F} = \frac{A_1E}{FG} \Rightarrow \frac{145}{205} = \frac{145}{205} = \frac{130}{FG}$$

$$FG = \frac{130 \times 205}{145} \Rightarrow FG = 183.79 \Rightarrow FG \approx 184$$

$FG = 184 \Rightarrow$  The width of cutting =  $184 + r + r \Rightarrow$  The width of cutting =  $184 + 50 +$

$50 \Rightarrow$  The width of cutting = 284 mm

The width of the machine in position 3 ( $A_1B_3$ )

$$A_1D = r = 65\text{mm} = a$$

$$B_3D = 110\text{ mm} = b \Rightarrow c^2 = a^2 + b^2 \Rightarrow$$

$$c^2 = (65)^2 + (110)^2 \Rightarrow c^2 = 4225 + 12100 \Rightarrow c^2 = 16325$$

$$\Rightarrow c = 127.76 \Rightarrow c \approx 128$$

$$350 - 128 = 222$$

$$\frac{A_1B_3}{B_3G} = \frac{EB_3}{B_3F} = \frac{A_1E}{FG} \Rightarrow \frac{128}{222} = \frac{128}{222} = \frac{130}{FG}$$

$$FG = \frac{130 \times 222}{128} \Rightarrow FG = 225.46 \Rightarrow FG \approx 225 \text{mm}$$

The width of cutting =  $225 + r + r \Rightarrow$  The width of cutting =  $225 + 50 + 50$   
 $\Rightarrow$  The width of cutting = 325mm

The width of the machine in position 4 ( $A_1B_4$ )

$$A_1D = r = 65 \text{mm} = a$$

$$B_4D = 90 \text{mm} = b \Rightarrow$$

$$c^2 = a^2 + b^2 \Rightarrow c^2 = (65)^2 + (90)^2 \Rightarrow c^2 = 4225 + 8100$$

$$\Rightarrow c^2 = 12325 \Rightarrow c = 111.01 \Rightarrow c \approx 111$$

$$350 - 111 = 239$$

$$\frac{A_1B_4}{B_4G} = \frac{EB_4}{B_4F} = \frac{A_1E}{FG} \Rightarrow \frac{111}{239} = \frac{111}{239} = \frac{130}{FG}$$

$$\Rightarrow FG = \frac{130 \times 239}{111} \Rightarrow FG = 279.90 \Rightarrow FG \approx 280 \text{mm}$$

The width of cutting =  $280 + r + r \Rightarrow$  The width of cutting =  $280 + 50 + 50 \Rightarrow$   
 The width of cutting = 380mm

The width of the machine in position 5 ( $A_2B_1$ )

$$A_2D = r = 45 = a$$

$$B_1D = 150 = b \Rightarrow$$

$$c^2 = a^2 + b^2 \Rightarrow c^2 = (45)^2 + (150)^2 \Rightarrow c^2 = 2025 + 22500$$

$$\Rightarrow c^2 = 24525 \Rightarrow c = 156.6 \Rightarrow c \approx 157$$

$$350 - 157 = 193$$

$$\frac{A_2B_1}{B_1G} = \frac{EB_1}{B_1F} = \frac{A_2E}{FG} \Rightarrow \frac{157}{193} = \frac{157}{193} = \frac{90}{FG} \Rightarrow FG = \frac{193 \times 90}{157} \Rightarrow FG = 110.6 \Rightarrow FG \approx 111 \text{mm}$$

The width of cutting =  $FG + r + r = 111 + 50 + 50 \Rightarrow$  The width of cutting = 211mm

The width of the machine in position 6 ( $A_2B_2$ )

$$A_2D = r = 45 = a$$

$$B_2D = 130 = b \Rightarrow$$

$$c^2 = a^2 + b^2 \Rightarrow c^2 = (45)^2 + (130)^2 \Rightarrow c^2 = 2025 + 16900$$

$$\Rightarrow c^2 = 18925 \Rightarrow c = 137.56 \Rightarrow c \approx 138$$

$$(350 - 138 = 212)$$

$$\frac{A_2B_2}{B_2G} = \frac{EB_2}{B_2F} = \frac{A_2E}{FG} \Rightarrow \frac{138}{212} = \frac{138}{212} = \frac{90}{FG} \Rightarrow FG = \frac{90 \times 212}{138} \Rightarrow FG = 138.2 \Rightarrow FG \approx 138$$

$FG \approx 138$ , The width of cutting =  $FG + r + r = 138 + 50 + 50 \Rightarrow$  The width of cutting = 238mm

The width of the machine in position 7 ( $A_2B_3$ )

$$A_2D = r = 45 = a$$

$$B_3D = 110 = b \Rightarrow$$

$$c^2 = a^2 + b^2 \Rightarrow c^2 = (45)^2 + (110)^2 \Rightarrow c^2 = 2025 + 12100$$

$$\Rightarrow c^2 = 14125 \Rightarrow c = 118.8 \Rightarrow c \approx 119$$

$$350 - 119 = 231$$

$$\frac{A_2B_3}{B_3G} = \frac{EB_3}{B_3F} = \frac{A_2E}{FG} \Rightarrow \frac{111}{231} = \frac{111}{231} = \frac{90}{FG} \Rightarrow FG = \frac{231 \times 90}{111} \Rightarrow FG = 187.29 \approx 187 \text{mm}$$

The width of cutting =  $FG + r + r = 187 + 50 + 50 \Rightarrow$  The width of cutting = 287mm

The width of the machine in position 8 ( $A_2B_4$ )

$$A_2D = r = 45 = a$$

$$B_4D = 90 = b \Rightarrow$$

$$c^2 = a^2 + b^2 \Rightarrow c^2 = (45)^2 + (90)^2 \Rightarrow c^2 = 2025 + 8100$$

$$\Rightarrow c^2 = 10125 \Rightarrow c = 100.6 \Rightarrow c \approx 101$$

$$350-101=249$$

$$\frac{A_2B_4}{B_4G} = \frac{EB_4}{B_4F} = \frac{A_2E}{FG} \Rightarrow \frac{101}{249} = \frac{101}{249} = \frac{90}{FG} \Rightarrow FG = \frac{249 \times 90}{101} \Rightarrow 221.88 \Rightarrow FG \approx 222$$

$$\text{The width of cutting} = FG + r + r = 222 + 50 + 50 \Rightarrow \text{The width of cutting} = 322\text{m}$$

The width of the machine in position 9 ( $A_3B_1$ )

$$A_3D = r = 25 = a$$

$$B_1D = 150 = b \Rightarrow$$

$$c^2 = a^2 + b^2 \Rightarrow c^2 = (25)^2 + (150)^2 \Rightarrow c^2 = 625 + 22500$$

$$\Rightarrow c^2 = 23125 \Rightarrow c = 152.06 \Rightarrow c \approx 152$$

$$350-152=198$$

$$\frac{A_3B_1}{B_1G} = \frac{EB_1}{B_1F} = \frac{A_3E}{FG} \Rightarrow \frac{152}{198} = \frac{152}{198} = \frac{50}{FG} \Rightarrow FG = \frac{198 \times 50}{152} \Rightarrow FG = 65.13 \Rightarrow FG \approx 65$$

$$\text{The width of cutting} = FG + r + r \Rightarrow \text{The width of cutting} = 65 + 50 + 50 = 165\text{m}$$

The width of the machine in position 10 ( $A_3B_2$ )

$$A_3D = r = 25 = a$$

$$B_2D = 130 = b \Rightarrow$$

$$c^2 = a^2 + b^2 \Rightarrow c^2 = (25)^2 + (130)^2 \Rightarrow c^2 = 625 + 16900$$

$$\Rightarrow c^2 = 17525 \Rightarrow c = 132.38 \Rightarrow c \approx 132$$

$$350-132=218$$

$$\frac{A_3B_2}{B_2G} = \frac{EB_2}{B_2F} = \frac{A_3E}{FG} \Rightarrow \frac{132}{218} = \frac{132}{218} = \frac{50}{FG} \Rightarrow$$

$$FG = \frac{50 \times 218}{132} \Rightarrow FG = 82.57 \Rightarrow FG \approx 83$$

$$\text{The width of cutting} = FG + r + r \Rightarrow \text{The width of cutting} = 83 + 50 + 50 = 183\text{mm}$$

The width of the machine in position 11 ( $A_3B_3$ )

$$A_3D = r = 25 = a$$

$$B_3D = 110 = b \Rightarrow$$

$$c^2 = a^2 + b^2 \Rightarrow c^2 = (25)^2 + (110)^2 \Rightarrow c^2 = 625 + 12100$$

$$\Rightarrow c^2 = 12725 \Rightarrow c = 112.80 \Rightarrow c \approx 113$$

$$350-113=237$$

$$\frac{A_3B_3}{B_3G} = \frac{EB_3}{B_3F} = \frac{A_3E}{FG} \Rightarrow \frac{113}{238} = \frac{113}{238} = \frac{50}{FG} \Rightarrow$$

$$FG = \frac{50 \times 238}{113} \Rightarrow FG = 105.30 \Rightarrow FG = 105$$

$$\text{The width of cutting} = FG + r + r \Rightarrow \text{The width of cutting} = 105 + 50 + 50 \Rightarrow 205$$

= The width of cutting

The width of the machine in 12 ( $A_3B_4$ )

$$A_3D = r = 25 = a$$

$$B_4D = 90 = b \Rightarrow$$

$$c^2 = a^2 + b^2 \Rightarrow c^2 = (25)^2 + (90)^2 \Rightarrow c^2 = 625 + 8100$$

$$\Rightarrow c^2 = 8725 \Rightarrow c = 93.40 \Rightarrow c \approx 93$$

$$350-93=257$$

$$\frac{A_3B_4}{B_4G} = \frac{EB_4}{B_4F} = \frac{A_3E}{FG} \Rightarrow \frac{93}{257} = \frac{93}{257} = \frac{50}{FG} \Rightarrow$$

$$FG = \frac{50 \times 257}{93} \Rightarrow FG = 138.17 \Rightarrow FG \approx 138$$

The width of cutting =  $FG + r + r \Rightarrow$  The width of cutting =  $138 + 50 + 50 \Rightarrow 238$   
 = The width of cutting

**Table 12: Final specifications of the machine**

number	position	The width of cutting
1	(A <sub>1</sub> – B <sub>1</sub> )	247mm
2	(A <sub>1</sub> – B <sub>2</sub> )	284mm
3	(A <sub>1</sub> – B <sub>3</sub> )	325mm
4	(A <sub>1</sub> – B <sub>4</sub> )	380mm
5	(A <sub>2</sub> – B <sub>1</sub> )	211mm
6	(A <sub>2</sub> – B <sub>2</sub> )	238mm
7	(A <sub>2</sub> – B <sub>3</sub> )	287mm
8	(A <sub>2</sub> – B <sub>4</sub> )	322mm
9	(A <sub>3</sub> – B <sub>1</sub> )	165mm
10	(A <sub>3</sub> – B <sub>2</sub> )	183mm
11	(A <sub>3</sub> – B <sub>3</sub> )	205mm
12	(A <sub>3</sub> – B <sub>4</sub> )	238mm

## Conclusion

In this study a mechanical robot was designed that can move between the rows on a monorail in the greenhouse. The arm of this robot has the ability to go in the space between the plants and cut the weeds. Six engine speeds of 30-40-50-60-80- 120 rpm were tried to test the proper speed. After various tests on each of the motors 50 and 60 rpm were selected. Both seemed to work well for the robot, but since one of the objectives of the study is to cut the weeds in the minimum time, the engine speed was 60 rpm, so a shorter time interval between the two main plants is used. To select the best arm speed, two motors with speeds of 10 and 30 rpm were used. Since the study results indicated that as much as the speed of the engine is further, the percentage of

cut weeds reduces, therefore, the motor of 10-rpm was selected to move the arm. To choose the best type of blade, three blade types of A (Moulinex), blade B (triangular) or C (circular) were used. The average percentage of cut weeds by the blades had significant differences. After selecting three types of blades A, B, C, each was investigated in the three speeds, 1500, 2500 and 3500 rpm. The highest and the lowest cut weeds were obtained in use of the 3500 rate and in 1500 rpm for the rotating blade.

None of the effects of combination of ANOVA was significant. The comparison of the test showed that if the blade rotation speed is low, it will have a significant effect on the number of cut weeds. By increasing rotational speed of the blades, the efficiency of the blade showed no significant differences. For all the blades the most percentage of the cut weeds was obtained with a rotation speed of 3500 rpm. The effects of combination of speed of arm and type of blade indicated that the blades type in the speed of 10 rpm, the movement of the engine arm, had a significant effect on the percentage of cut weeds and that while the percentage of the cut weeds by the Moulinex blades was maximized, increase in the speed to 30 rpm, there is a reduction in the efficiency of the Moulinex blade arm and all the other types.

The analysis of the interaction of the blade speed and blade type showed that (a) none of the mutual interactions was significant in the variance test. (b) t-test showed that if the rotational speed of the blade was low, the blade type would have a significant effect on the NW cut. (c) The increase in the blades 'rotational speed, the efficiency of the blades did not change significantly. (d) For all the blade types, the highest percentage of the weeds cut was at 3500 rpm. Studying the interactive effect of blade rotational speed and the motor arm speed indicated that if the speed of the motor arm is 10rpm and the blade rotational speed is 3500 rpm, percentage of cut weed will be maximized and that the lowest percentage occurred in the blade rotational speed of 1500 rpm and 30 rpm speed of the motor arm. In each motor arm speed, the increase in the rotational blade speed caused an increase in percentage of cut weeds. If the motor arm speed is increased in each rotational blade speed, the percentage of cut weeds will decrease. The comparison of the interactions between the three different types of blades, blade speed and the speed of the arm demonstrated that the most percentage of the cut weeds was obtained when the Moulinex blade at the rotational speed of 3500 rpm was used and engine speed was 10rpm. The lowest percentage of cut weeds was obtained when the blade speed was 1500 and the speed of motor arm was 10 rpm and the blades types were triangular and circular. Regarding the speed of the machine and also the speed of the motor arm from the time it stops on the first stopper, up to the end of a cycle and it takes 10 seconds for restarting of the machine to the next stopper and the next cycle.

It can be recommended that since most of the greenhouse farmers have the low literacy, they will refuse to use a complicated system. Because they are always worry that having a mistake in using the system will cause their product to be damaged, so it should be tried to offer them a simple system not a complicated one. Low cost is one of the ways that we can put a new idea into a community, especially in the farmers' community. Therefore, in designing of this system it was tried to use the simplest methods and technologies.

## References

1. Arsalanbod, M. and Roland D. Kay. (2013). Farm Management-Planting, Control, and Implementation. Agricultural Department, Oromieh, Iran
2. Astrand, B. and Baerveldt, A. J. (2003). Mobile Robot for Mechanical Weed Control. *Int. Sugar J.*, 105(1250): 89-95.
3. Baskin, Y. (1996). Curbing undesirable aliens. *Bioscience* 46(10): 732–736.
4. Baumann, P.A., D.H. Bade, and D.L. Biediger. (1991). Forage grass response to chemical and mechanical weed control measures. *Abstr., Proc. 44th South. Weed Sci. Soc.* p. 193.
5. Belforte, G., R. Deboli, P. Gay, P. Piccarolo, and D. Ricauda. (2006). Robot design and testing for greenhouse applications. *Biosystems Eng.* 95(3): 309-321.
6. Billingsley, John, Arto Visala, Arto, Mark, Dunn. (2007). *Robotics in Agriculture and Forestry*, Chapter 46, p:2-14.
7. Borenstein, J.; Everett, H.R.; Feng, L. (1996). *Navigating Mobile Robots. Systems and Techniques*, 1st ed.; A.K. Peters, Ltd.: Wellesley, MA, USA.
8. Burks, T. F., Shearer, S. A., Heath, J. R. and Donohue, K. D. (2005). Evaluation of Neuralnetwork Classifiers for Weed Species Discrimination. *Biosystems Engineering* 91(3), 293-304.
9. Cho, S. I., Lee, D. S. and Jeong, J. Y. (2002). Weed-plant Discrimination by Machine Vision and Artificial Neural Network. *Biosystems Eng.*, 83 (3): 275–280.
10. Dario, P., G. Sandini, B. Allotta, A. Bucci, F. Buemi, M. Massa, F. Ferrari, M. Magrassi, L. Bosio, R. Valleggi, E. Gallo, A. Bologna, F. Cantatore, G. Torrielli, and A. Mannucci. (1994). The Agrobot Project for greenhouse automation. *Acta Hort. (ISHS)* 361: 85-92.
11. Giacomelli G.A., and Ting K.C. (1995) "Transportation and Robotics for greenhouse Crop Production Systems", *Acta Hort (ISHS)*, Vol 399, pp. 49-60.
12. González. R., Rodríguez. F., Sánchez-Hermosilla. J., G. Donaire. J. (2009). Navigation techniques for mobile robots in greenhouses. *Applied Engineering in Agriculture*. Vol. 25(2): 153-165. American Society of Agricultural and Biological Engineers.
13. Hopkins, M. (2000). Automating in the 21st Century Career and Technical Education", *Greenhouse Grower*, pp. 4-12.
14. Jafari, A., Mohtasebi, S. S., Eghbaliand, H. and Omid, M. (2006). Weed Detection in Sugar Beet Fields Using Machine Vision.
15. Julián Sánchez-Hermosilla 1, Ramón González 2, Francisco Rodríguez 2 and Julián Jacob Carbalido, Manuel Perez-Ruiz, ChrisGliever, Juan Agüera, Design. (2011). development and lab evaluation of a weed control sprayer to be used in robotic systems. First RHEA International Conference on Robotics and associated High-technologies and Equipment for Agriculture Hosted by the University of Pisa, Italy, September 19-20-21.
16. Kiani1, S and Jafari, A (2012). Crop Detection and Positioning in the Field Using Discriminant Analysis and Neural Networks Based on Shape Features. *J. Agr. Sci. Tech.* Vol. 14: 755-765.
17. Kondo, N., and K. C. Ting. (1998). Robotics for plant production. *Artificial Intelligence Review* 12: 227-243.
18. Lamm, R. D. Slaughter, D C. Giles, D K. (2002). *Transactions of the ASABE*. Vol. 45(1): 231–238 . (doi: 10.13031/2013.7861).
19. Langenakens, J.; Vergauwe, G.; De Moor, A. (2002). Comparing hand-held spray guns and spray booms in lettuce crops in a greenhouse. *Aspects Appl. Biol.* 66, 123–128.
20. Lee, W.S. Slaughter, D C. Giles, D K. (1999). Robotic weed control system for tomatoes. *Precision agriculture*, 1, 95-113. Kluwer Academic Publishers. Manufactured in the Netherlands.
21. Mandow, A.; Gómez de Gabriel, J.M.; Martínez, J.L.; Muñoz, V.F.; Ollero, A; García-Cerezo, A. (1996). The autonomous mobile robot Aurora for greenhouse operation. *IEEE Robot. Auto. Mag.*, 3, 18–28.
22. Martinez, J. L., A. Mandow, J. Morales, S. Pedraza, and A. Garcia-Cerezo. (2005). Approximating kinematics for tracked mobile robots. *The Intl. J. of Robotics Res.* 24(10): 867-878.
23. Meyer, G. E. Mehta, T., Kocher, M. F., Mortensen, D. A., Samal, A. (1998). Textural Imaging and Discriminant Analysis for Distinguishing Weeds for Spot Spraying. *Transactions of the ASAE*, 41(4), 1189– 1197.
24. Mohammadi monavar, Hasan. Alimardani, Reza. Mahmud, Omid. (2013). *Journal of Agricultural Machinery* Vol. 3, No. 1, Spring - Summer 2013, p. 9-15 (in Farsi).
25. Monta, M. (2000). Robot for bioproduction systems. 2nd IFAC/CIGR International workshop on Bio-Robotics, Information Technology and Intelligent Control for Bioproduction Systems. Osaka, Japan.

26. Nuyttens, D., S. Windey, and B. Sonck. (2004). Comparison of operator exposure for five different greenhouse spraying applications. *J. Agric. Safety and Health* 10(3): 187-195.
27. Ollero, A., A. Mandow, V. F. Muñoz, and J. Gómez de Gabriel. (1994). Control architecture for mobile robot operation and navigation *Robotics. & Computer- Integrated- Mfg.* 11(4): 259-269.
28. Pan, J., Min, H. and Yong, H. (2007). Crop and Weed Image Recognition by Morphological Operations and ANN Model. *Instrumentation and Measurement, Technology Conference – IMTC.* Warsaw, Poland, May 1-3, 2007.
29. Pe´rez, A. J., Lopez, F., Benlloch, J. V. and Christensen, S. (2000). Colour and Shape Analysis Techniques for Weed Detection in Cereal Fields. *Comput. Electron. Agric.* 25: 197–212.
30. Persson, S. (1987). *Mechanics of Cutting Plant Material.* Vol. Monograph No. 7. St Joseph, MIch., USA: ASAE.
31. Pilarski, T., Happold, M., Pangels, H., Ollis, M., Fitzpatrick, K., Stentz A. (2002). "The Demeter System for Automated Harvesting", *Autonomous Robots*, Vol 13, pp. 9-20.
32. Polder, G., Van Evert, F. K., Lamber, A. (2007). Weed Detection Using Textural Image Analysis. EFITA. <http://www.efita.net/apps/accesbase/dbsommaire.asp?d = 6257>.
33. Popay, I., and R. Field. (1996). Grazing animals as weed control agents. *Weed Technol.* 10:217–231.
34. Sánchez-Hermosilla, J.; Rincón, V.J.; Páez, F.; Agüera, F.; Carvajal, F. (2011). Field evaluation of a self-propelled sprayer and effects of the application rate on spray deposition and losses to the ground in greenhouse tomato crops. *Pest Manag. Sci.* 2011, 67, 942–947.
35. Sánchez-Hermosilla, J.; Rodríguez, F.; González, R.; Guzmán, J.L.; Berenguel, M. (2010). A Mechatronic Description of an Autonomous Mobile Robot for Agricultural Tasks in Greenhouses. In *Mobile Robots Navigation*; Barrera, A., Ed.; InTech.: Rijeka, Croatia,; pp. 583–608.
36. Sandini, G., F. Buemi, M. Massa, and M. Zucchini. (1990). Visually guided operations in greenhouses. *IEEE Intl. Workshop on Intelligent Robots and Systems.* Piscataway, N.J.: IEEE.
37. Sezen, B. (2003), "Modelling Automated Guided Vehicle Systems in material Handling", *Dogus Universitesi Dergisi*, Vol 4, No. 3, pp. 207-216.
38. Singh, S., T. F. Burks, and W. S. Lee. (2004). Autonomous robotic vehicle for greenhouse spraying. ASAE Paper No. 043091. St. Joseph, Mich.: ASAE.
39. Smith, B., P. Leung, and G. Love (ed.). (1986). *Intensive grazing management: forage, animals, men, profits.* Graziar's Hui. Kamuela, Hawaii.
40. Subramanian, V., T. F. Burks, and S. Singh. (2005). Autonomous greenhouse sprayer vehicle using machine vision and ladar for steering control. *Applied Eng. in Agric.* 21(5): 935-943.
41. Van Henten, E.J. Van Tuijl, B.A.J. Hoogakker, G-J. Van Der Weerd, M.J . Hemming, J.J. Kornet, J.G and Bontsema, J (2005). An Autonomous Robot for De-leafing Cucumber Plants Grown in a High-wire Cultivation System, Greenhouse Technology Group, Agrotechnology & Food Innovations Ltd. P.O. Box 17, NL6700 AA Wageningen The Netherlands.
42. Van Henten, E.J., Van Tuijl, B.A.J, Hemming, J., Kornet, J.G., Bontsema, J. and Van Os, E.A. (2003). Field test of an autonomous cucumber picking robot. *Biosystems Engineering*, 86(3): 305-313.
43. Zhu, B., Jiang, L., Luo, Y. and Tao, Y. (2007). Gabor Feature-based Apple Quality Inspection Using Kernel Principal Component Analysis. *J. Food Eng.* 8(4): 741-749.