

---

## Original Research Article

# OPTIMIZATION OF STEAM BOILER AIRFLOW CONTROL SYSTEM IN A TYPICAL OIL REFINERY POWER PLANT

To address this, the damper-louvers system was replaced with a Variable Frequency Drive (VFD), which would adjust the motor speed to match the required airflow, thereby reducing energy wastage. The process was simulated and VFD/FDF motor analyzed in MATLAB Simulink, determining the optimal speed, airflow, and power requirements. Results obtained show that the VFD control system improves the FDF motor's power efficiency from 47.7% to 85%, with an annual energy saving of 8,502,302 kWh (8.5 GWh). This results in a total cost benefit of N478.18 million annually, representing a 43.8% cost saving. The implementation cost of the VFD infrastructure was estimated at N111, 440,000, with a payback period of approximately eleven months. The findings suggest deployment of higher FDF motor speed ratings to enhance speed control and energy efficiency in Oil refinery power plant.

## ABSTRACT

This paper presents optimization of Steam Boiler Airflow Control System in a Typical Oil Refinery Power Plant. The power plant is equipped with four steam boilers using a damper-louvers airflow control system. Analysis has revealed significant energy wastage due to inefficiency and over-air supply, with the system requiring 59,904,436 kWh annually at a financial cost of N1, 093,255,884. The existing system's inefficiency results in an annual electrical energy waste of 8,502,302 kWh. This inefficiency is attributed to the Force Draft Fan (FDF) motor operating at maximum speed continuously, regardless of the steam profile or airflow requirements. This study aimed at optimizing the steam boiler airflow control system in a typical oil refinery power plant for improved power efficiency, energyconservation, and cost savings citing Port Harcourt Refinery Company (PHRC) at Alesa-Elеме, Rivers State, Nigeria.

*Keywords: Force Draft Fan, Variable Frequency Drive, Airflow control system, MATLAB Simulink, energy conservation, Cost saving opportunity, PHRC.*

## 1. INTRODUCTION

In a typical refinery, steam generation is crucial to support various operations, requiring substantial financial and resource investments. Ensuring maximum efficiency and cost-effectiveness in steam generation is essential, and the process must continually adapt to advancements in technology [1]. As refineries face increasing demands and limited resources, enhancing the efficiency of steam boilers and minimizing waste become imperative. Port Harcourt Refining Company Limited (PHRC), a

subsidiary of the Nigerian National Petroleum Company (NNPC) Limited, located at Alesa-Elеме in Rivers State, Nigeria, operates with a refining capacity of 210,000 barrels per day. The refinery loses a substantial amount of money, over 480 million naira per year, due to poor efficiency of the steam boiler airflow control system. Based on investigation, a sizable number of refineries and steam power plants across the globe were besieged with similar challenge. The Louvers damper control system is used to control boiler combustion airflow. This system allows the FDF electric motor to run

continuously at full-load speed, generates maximum airflow irrespective of the airflow required for combustion, and as such, always consumes maximum power, even when a low airflow profile is needed. The excess air generated by the fan is discharged into the atmosphere through a damper louvers-controlled system opening; this is a huge waste. This technique is inefficient and energy sapping. The refinery converts crude oil into finished petroleum products and is equipped with a 4 x 14 MW steam turbines power plant as one of its power sources[2]. Over time, the degradation of the refinery's power system has led to inefficiencies and elevated operational costs, adversely impacting the refinery's production and increasing expenses. A significant portion of the power generated at the refinery is consumed by electric motors. Implementing efficient drive systems can lead to substantial energy savings. Variable Frequency Drives (VFDs) are known for their energy efficiency and their ability to significantly reduce electricity consumption and operational costs for electric motors. This study focuses on improving the cost-effectiveness and operational efficiency of the Force Draft Fan (FDF) motor by integrating a VFD system.

## 2. REVIEWED WORKS

In oil refinery power plants, where process variability is high, the implementation of optimized airflow control systems has proven to be particularly beneficial [3]. Studies have demonstrated that refineries using advanced control systems for boiler optimization have seen substantial improvements in operational efficiency and reductions in operational costs. In [4], it was stated that airflow control in steam boilers directly impacts the combustion process, as it determines the amount of oxygen available to react with the fuel. An excess of air can lead to energy losses, while insufficient air results in incomplete combustion and increased emissions of carbon monoxide and unburned hydrocarbons. These systems also contribute to better compliance with environmental regulations, as they help minimize pollutant emissions as in [5]. LEMTEK UI has reported that air fan system currently used in Power Plant of PLTU Tanjung Jati B Jepara is inefficient. Inefficiency of the air fan system has resulted to waste of electric energy amount of 13,352,929 KWh (13,35 GWh) a year with a financial loss of IDR 13,352,929,140 [6]. Steam boilers are a critical component in oil refineries, where they are used to generate steam for various process heating requirements, including distillation, cracking, and other thermal operations. Effective boiler operation has been a key to maximizing energy efficiency and minimizing fuel consumption, as well as reducing greenhouse gas emissions [7]. Research in [8] has shown that the implementation of these techniques can reduce fuel consumption by up to 10% and significantly lower emissions.[9] Stated that the efficiency of these boilers is largely dependent on the balance between fuel input and the airflow required

for complete combustion. In many refineries, traditional control methods are still used, often resulting in suboptimal performance due to the dynamic nature of refinery operations. Recent advancements in control theory and optimization techniques have opened up new possibilities for improving steam boiler efficiency. Techniques such as model predictive control (MPC) and artificial intelligence-based approaches, including neural networks and fuzzy logic, have been applied to the optimization of airflow in industrial boilers [10]. Modern control systems aim to maintain an optimal air-to-fuel ratio, ensuring efficient combustion under varying operating conditions. Several studies have highlighted the importance of using advanced control algorithms to optimize this process, with significant improvements in both efficiency and emissions reduction [11]. These methods enable real-time adjustments based on predictive models of the boiler's behaviour, leading to more accurate control and improved performance [12]. Despite these advantages, the adoption of such technologies remains limited in many refineries, primarily due to the cost of implementation and the complexity of integrating new control systems with existing infrastructure as stated in [13]. In [14], factor affecting efficiency of a power plant, effect of operational practices, choice of fuel, and technologies available for improving the thermal power plant efficiency were analysed. A conceptual model was formed from the review conducted to verify the thematic analysis method for improving thermal power plant efficiency. Research findings in [15] reveal that the power demand of the refinery is quite enormous, and it is of absolute importance to ensure efficient and cost-effective operation of the plant. This necessitates the need to optimize the steam boiler airflow control system in a typical oil refinery steam power plant for maximum efficiency. Evaluation of PHRC steam boilers performance reveals that the boiler air fan motor is not efficient as it supplies excess air; this is attributed to the boiler's poor airflow control system. Energy efficiency of the forced draft fan (FDF) is only 47.7%. The flow rate capacity of the FDF is 143KNM<sup>3</sup>/hr but the flow rate utilized is 72KNM<sup>3</sup>/hr for complete combustion.

## 3. RESEARCH METHOD

The methodology adopted includes control strategy design, system modeling, and simulation-based optimization using MATLAB Simulink.

### A. Existing System:

A simplified schematic diagram of an existing steam boiler control system configured in PHRC boiler unit is shown in Fig. 1.

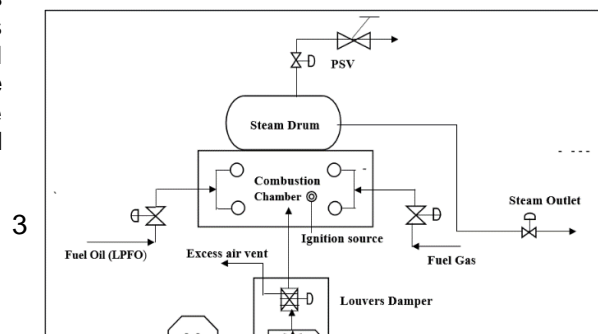
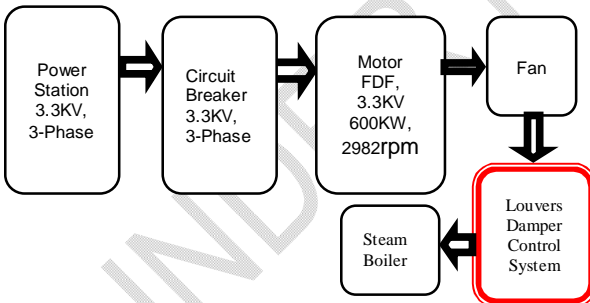

Fig. 1 is translated into fig. 2 as block diagram of the existing louvers damper Airflow control system. The FDF-motor is a 3.3 kilo-volts, 600KW motor with maximum speed of 2982 rpm. Power is supplied directly from a 3.3KV, 3 - phase circuit breaker. The motor runs at maximum rated speed at all times driving the FD fan that in turns generates maximum of airflow rate of  $143.1 \left(\frac{kNM^3}{hr}\right)$  meant for steam profile of 120 Tones/hr of steam as the maximum continuous rating and peak load for two hours at 138 Tones/hr with pressure and temperature of 43.5Bar and 405°C respectively. The air flows through an Air duct installed with a louvers damper system to regulate the amount of airflow into the combustion chamber. This control is done by adjusting the opening and closing of a set of louvers pedaled by a pneumatic system. The adjustment is based on the amount of steam needed. In most cases, the steam is generated at about 60Tonnes/hr, hence, only about  $78.3 \left(\frac{kNM^3}{hr}\right)$  airflow rate is needed, and then the excess air is vented into the atmosphere. This system design amount to energy wastage and it is less efficient.



**Fig. 2: Block diagram of the existing louvers damper Airflow control system**

### B. Modified System:

To overcome the inefficiency and over air supply, VFD implementation is recommended. VFD regulates the air supply by adjusting the motor speed so that there is just sufficient combustible air for any giving steam profile without excess air being generated, translating to decrease in electrical power demand, saving electrical energy and system efficiency improvement. The VFD control system block diagram is shown in fig.3.

### C. System Equations

The variable frequency drive (VFD) powers the FDF - motor with varying supply frequency between (2.5-50Hz) to drive the motor at varying speed corresponding to the supply frequency. Thus, with the shaft of the FD fan connected with the asynchronous motor, varying air flow that matches the motor speed is generated into the steam boiler. This resulted by adjusting the frequency through the VFD and can control the speed of the induction motor since the relationship between the speed and frequency (f) is given by equation 1:

$$Speed = \frac{120 \times f}{number\ of\ pole} \quad (1)$$

The electrical power being consumed through the VFD is calculated based on the voltage drop and current being drawn by the load (electric motor) and the relationship is given by equation 2:

$$P = \sqrt{3} \cdot V \cdot I \cdot \cos\theta \quad (2)$$

Where: P: Electrical power at load (W). V: Voltage drop at the load (V). I: Current being drawn by the load (A).  $\cos\theta$ : Power factor at the load.

The financial cost calculation of electric power based on the amount of power during running hours is given by equation 3:

$$Fin\ cost = P \times RH \times P\ per\ KWh \quad (3)$$

Where: P: Electric power (W). RH (Running hours): VFD working duration (hours). Price per KWh: Electricity per price in KWh ratings. The savings opportunity is the difference between the installed device power and the device power in a simulation as given by equation 4:

$$S = Real\ power - Simulated\ power \quad (4)$$

Where: S is saving opportunity, Real power: Total active power of the FDF for any given duration. Simulated power: Total power gotten through Simulink simulation for any duration.

The efficiency of the FDF is the comparison between the total power output and total power input as given by equation 5:

$$\eta = \frac{dp \cdot Q}{\sqrt{3} \cdot V \cdot I \cdot \cos\theta} \times 100\% \quad (5)$$

Where:  $\eta$ : Fan efficiency,  $\Delta p$ : Differential pressure  $Q$ : Air debit, Total electric power input  $P = \sqrt{3} \cdot V \cdot I \cdot \cos\theta$ :

#### D. System Modeling

Figure 4 is a simulated circuit of the VFD to drive the FDF motor. The supply voltage first passes through the rectifier unit where it is converted from AC to DC voltage. The DC voltage enters the filter to reduce the harmonic distortion during AC to DC conversion. Main part is an inverter which consists of six insulated gate bipolar transistor (IGBT) to convert DC to AC. Various frequency are carried out by using the pulse width modulation (PWM) method in the inverter device, this device gives a combination of sine and saw signal pulses that vary according to the required needs. Speed of the motor depends on adjusted frequency. Therefore, by adjusting the frequency through to the VFD we can control the speed of the induction motor. The variable-frequency drive will help to deliver only the needed power to attain such speed for the desirable airflow; this is achieved by varying the frequency of the supply therefor saving energy and cost. The simulation blocks for the control system are as follows:

- i. **Rectifier and filter Stage:** A full wave rectifier section consists of solid-state rectifier converts three phase 50Hz power to either fixed DC voltage or variable DC voltage. DC link chopper removes unwanted signal harmonics and capacitor filter smoothen the rippled dc voltage, as shown in the simulated fig. 4.
- ii. **PWM Generator block:** PWM Generator block generates pulses for carrier-based pulse width modulation (PWM) converters using two-level topology. It is used to fire the forced commutated devices (FETs, GTOs, or IGBTs) of single phase, two-phase, three-phase, two-level bridges, or a combination of two three-phase bridges as shown in the simulated fig. 4.
- iii. **Inverter Stage:** uses power transistors or thyristors or IGBTs which switches the rectified DC voltage on and off, produces a current or voltage waveforms at the required frequency. The distortion occurred depends on the design of the inverter circuit and filter circuit as shown in the simulated fig. 4.
- iv. **Voltage, Current, fan speed and air flow output:** showcase the targeted outputs using the scopes as shown in the simulated fig. 4.
- v. **IGBT output:** This electronic switch enables the conversion between Direct Current (DC) and Alternating Current (AC). The quick switching between AC and DC enables precise control as they adjust power output to match motor needs as shown in the simulated fig. 4.
- vi. **Three Phases V-I Measurement:** a drive analyser that measures the dc bus voltage and current across the terminals when balance or unbalance as shown in the simulated fig. 4.
- vii. **Forced Draft Fan motor:** A forced draft fan (FD

fan) is a fan that is used to push air into a boiler or other combustion chamber. It is located at the inlet of the boiler and creates a positive pressure in the combustion chamber, which helps to ensure that the fuel burns properly and the boiler operates efficiently, as shown in the simulated fig. 4.

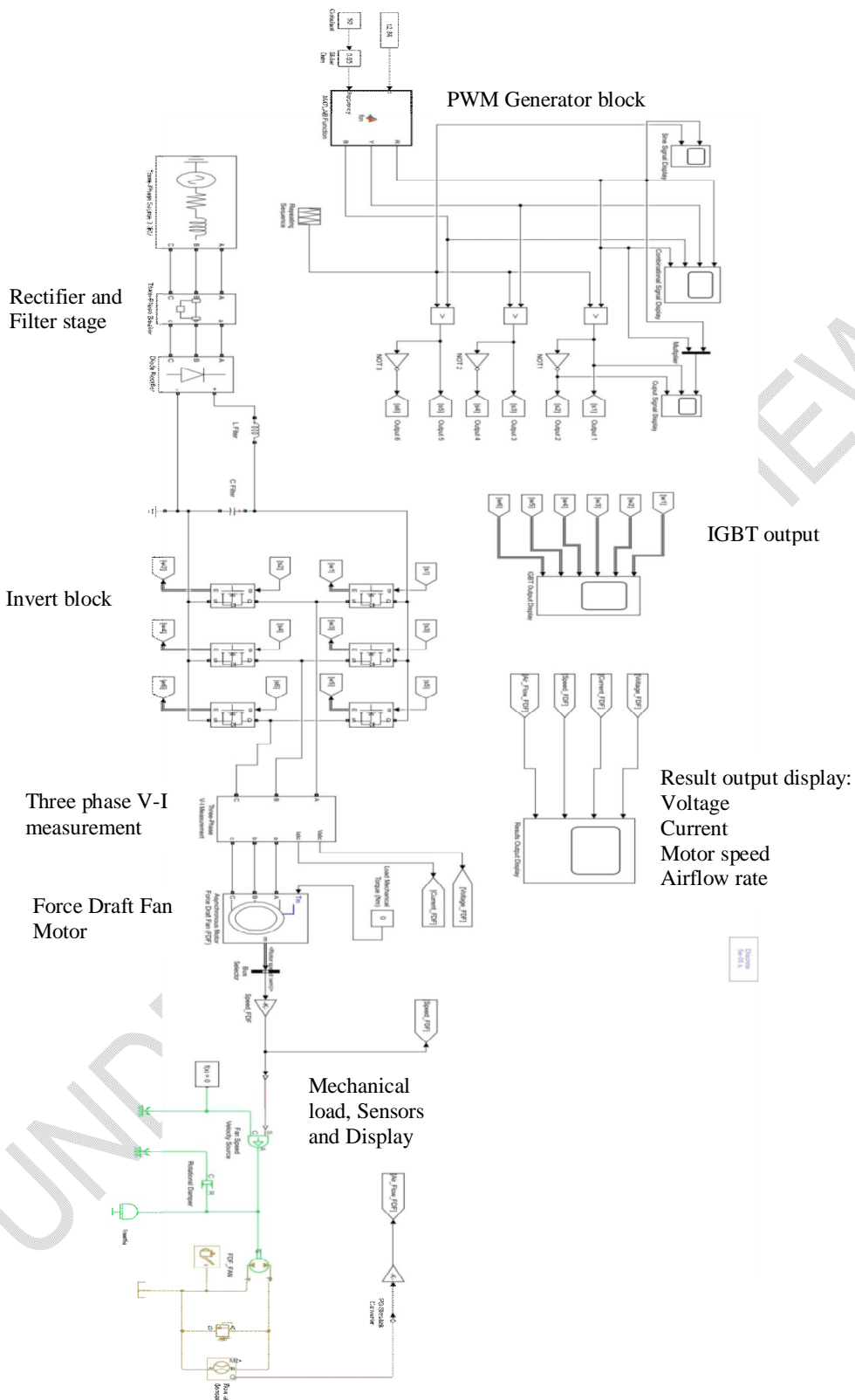

Fig. 4: Simulated blocks of the VFD control system

### E. VFD Control Algorithm

The following algorithm were developed and used for the VFD control system:

- Step 1: Power ON the system
- Step 2: initialize and generate pulse width modulation
- Step 3: Check the power parameter generated
- Step 4: Is the voltage generated between 955V and 3.3kV? If yes, go to step 5 for VFD control. If no, go to step 3
- Step 5: Apply rectification
- Step 6: Apply filter
- Step 7: Apply inverter IGBT
- Step 8: Measure the voltage and current
- Step 9: Drive the FDF motor & Fan with the PWM frequency generated
- Step 10: Generate airflow and control the speed of the steam boiler
- Step 11: is the airflow speed ok? If yes, go to step 10. If no, go to step 3

The flow chart of the VFD control is shown in fig.5

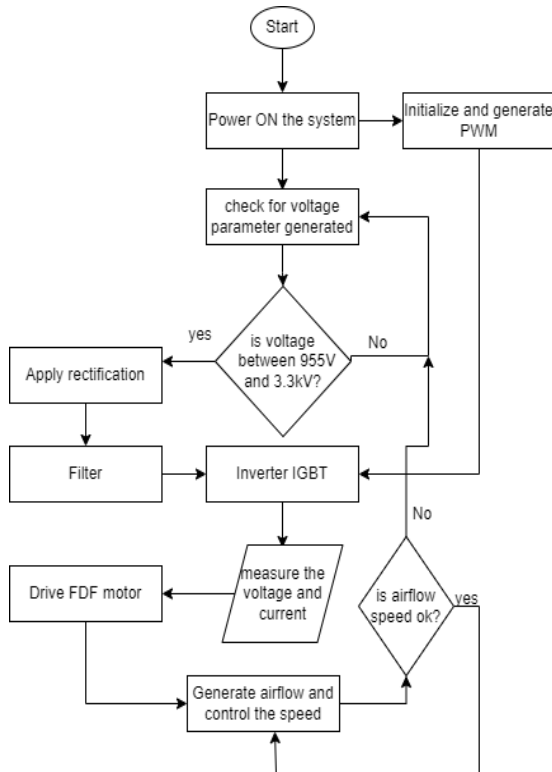

Fig.5: Flowchart of the proposed VFD control

The simulated parameters are shown in Table 1.

Table 1: VFD / Motor Parameters

No	Block name	Input Parameter
1	Power source	3 phase Configuration: Yg Vrms: 3300
2	Air circuit breaker	Breaker resistance: 0.01Ω Configuration: Y(grounded)
3	Diode Rectifier	Bridge arms: 3 Device: IGBT/Diode
4	L filter	Inductance: 80H
5	C filter	7500F
6	Function generator	Sequence: 3 phase Frequency: 50Hz
7	Digital clock	Clocking time: $1e^{-6}s$
8	Slider gain	Interval: 0-1
9	Repeating sequence	Time delay:
10	Relational operator	Relational: > Output data type: Boolean 1,2,3.
11	Not gate	Operation: Not Output data type: Boolean 1,2,3.
12	IGBT	Internal resistance: $1e^{-3}$ Snubber resistance: $1e^5$ 1,2,3,4,5,6
13	VI measurement	Measurement: phase to phase Current measurement: Yes
14	Asynchronous motor FDF	Rotor type: Squirrel cage Mechanical input: Torque Tm,0 Nominal power: 600000W Voltage: 3.3kv Frequency: 50Hz Pole: 2 Slip: 0.013
15	Bus selector	Mechanical motor speed (Wm)
16	Shaft speed	Velocity source: Torque sensor
17	FDF fan	Displacement: $5e^{-6}m^3/rad$ Nominal shaft angular velocity: 2982 Nominal fluid density: 1400000 No Load Torque: 10.9.
18	Scope Display	Sine signal display, Output signal display, IGBT output display, Combination signal display, Result output display

## 4. RESULTS AND DISCUSSION

### A. Analysis of the VFD Output Signals.

Varying frequency is the input signal to the simulation block. There are four (4) output signals of the VFD FDF each signal showing voltage, current, motor speed and airflow. The Simulation was done by varying the input frequency from 2.5 Hz to 50 Hz simultaneously with varying speed rate from (5%) to (100%). The variation of the input frequency is carried out in the signal generator section through the slider gain block. Every increase in frequency in the generator signal produced an increase in motor

voltage, speed and air flow rate. Data from the simulated results are shown in Table 2.

**Table 2: VFD Simulation Results**

S/N	VFD SET PT (%)	FREQUENCY (Hz)	VOLTAGE (V)	CURRENT (A)	SPEED (RPM)	AIR FLOW RATE ( $\frac{kNM^3}{hr}$ )
1	5	2.5	955	23.2	151.3	9.8
2	10	5	1050	40.34	390	14.41
3	15	7.5	1446	48.70	461.3	22.0
4	20	10	1574	28.40	602.0	33.43
5	25	12.5	1801	33.91	750.3	39.76
6	30	15	2205	35.74	900	42.9
7	35	17.5	2400	38.32	1050	50.08
8	40	20	2495	41.05	1200	57.24
9	45	22.5	2616	56.8	1385	66.05
10	50	25	2717	65.74	1500	72.81
11	55	27.5	2837	80.82	1650	79.62
12	60	30	2884	82.9	1800	86.5
13	65	32.5	2900	88.4	1938.3	92.95
14	70	35	2930	90.3	2087.4	100.1
15	75	37.5	2960	96	2236.5	107.2
16	80	40	2988	101.2	2400	115
17	85	42.5	3047	104.3	2550	121.6
18	90	45	3114	108.1	2700	128.8
19	95	47.5	3163	112.5	2847	135.8
20	100	50	3242	115.4	2997	143.1

Table 2 shows the lowest input frequency to be 2.5 Hz and the highest is 50 Hz, the lowest FDF voltage is 955 V, and the highest is 3242 V, the current ranges from 23.2 A to 115.4 A, while the lowest motor speed is 151.3 rpm and the highest is 2997 rpm. The lowest air flow obtained is 9.8 ( $\frac{kNM^3}{hr}$ ) while the highest is 143.1 ( $\frac{kNM^3}{hr}$ ).

From the data in Table 2, the relationship between varying frequency and the speed of the FDF motor is graphically represented in Fig.6. The graph shows the relationship between the variations of input frequency of the VFD from 2 Hz to 50 Hz with the speed of the FDF motor. It is quite evidenced that there is a linear relationship between the frequency and speed, increasing the frequency does results into increasing the speed of the FDF motor.

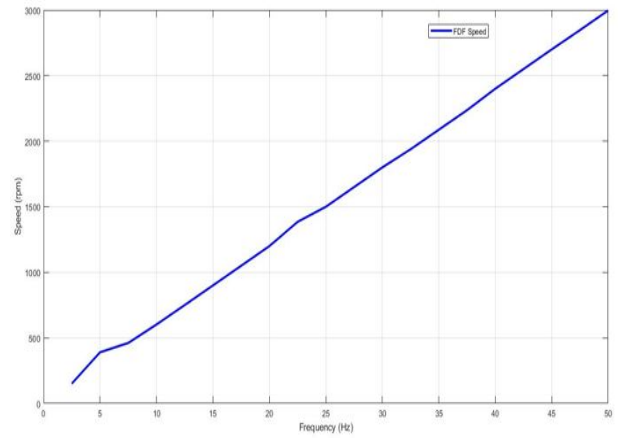

**Fig.6: Correlation between Frequency (input) and Speed of the VFD FDF**

Figure 7 gives the relationship between the speed and the air flow generated. This illustrates the correlation between the FDF speed and air flow rate as a linear function. The lower FDF motor speed yields a lower air flow rate while higher FDF motor yields a higher air flow rate, which means the rate change of speed is directly proportional to the rate of change of the air flow rate. This can be easily traced to the fact that shaft of the FDF fan is coupled with the FDF motor, thus as the motor is rotating at higher speeds, it will give higher air flow rate.

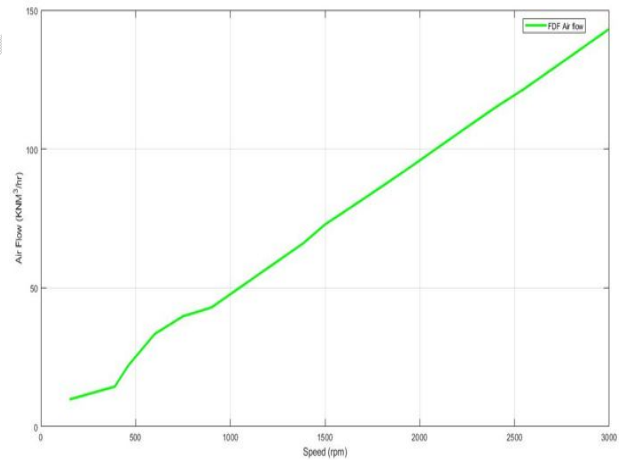

**Fig. 7: The Correlation between FDF Speed and Air Flow**

The relationship between the voltages of the FDF motor with the variation of the frequency is given in Fig. 8. As the frequency is being increased, the voltage is being increased. The rate of change of the frequency is directly to the rate of change of voltages. At lower frequency of 2.5Hz, the voltage is 955V, while at maximum frequency of 50Hz, the voltage is 3242V

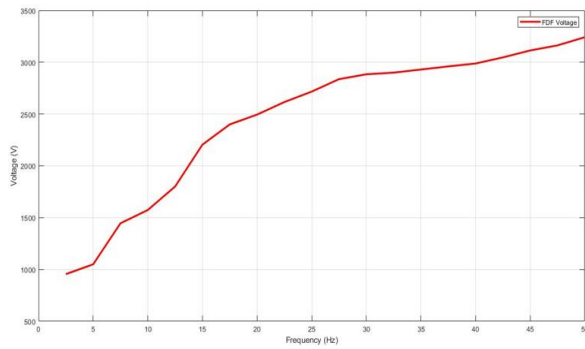

**Fig. 8: The Correlation between Frequency (input) and Voltage of the VFD FDF**

**A. Simulation Results**

The MATLAB/Simulink simulation of the Variable Frequency Drive (VFD) for the Forced Draft Fan (FDF) revealed that at an input frequency of 27.5 Hz (55% VFD set point), the motor operates at 1650 RPM, drawing 80.82 amps at 2837 volts to achieve an optimal airflow rate of 79.62 KNM<sup>3</sup>/hr. The simulation results are detailed in Fig. 9 through fig. 12:

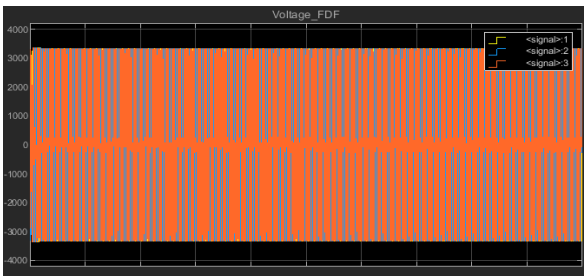

**Fig. 9: VFD Simulation Voltage Output Result**

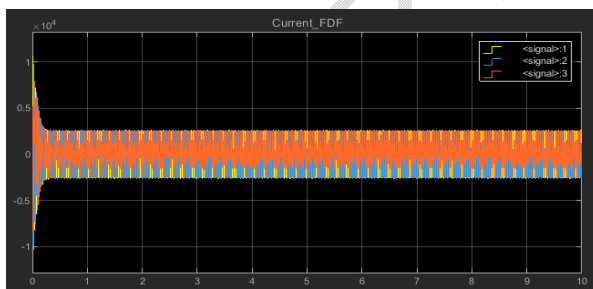

**Fig.10: VFD Simulation Current Output Result**

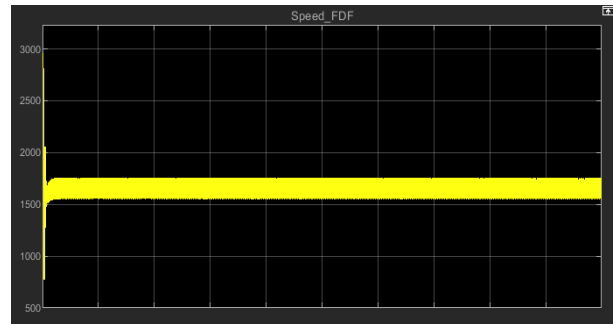

**Fig. 11: VFD Simulation Speed Result**

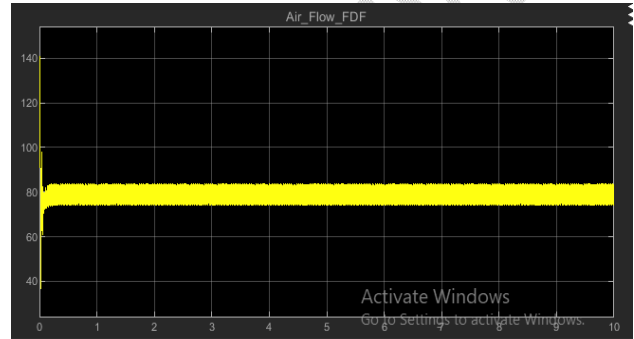

**Fig. 12: VFD Simulation Airflow Result**

**B. Power Calculation**

The simulation power calculation is carried out based on the data gotten from Table 2, VFD simulation results. From the data, the air flow rate value which is close to the actual air flow rate value needed for each of the four (4) boilers, the air flow rate value is 79.62 ( $\frac{kNM^3}{hr}$ ) for the Force Draft Fan (FDF) and the corresponding frequency is 27.5Hz (55% VFD set points). The air flow rate would show the frequency, voltage, current and motor speed values, and then the power calculated based on these values. Total running hours based on the operation time for 20 days is reduced by off time, the result is 448 hours. From the simulation result in table 2, for best result the VFD set point would be at 55% which is 27.5Hz. This would generate an optimum volume of 79.62KNM<sup>3</sup>/H airflow sufficient for the required combustion and steam production, judging by the maximum daily average airflow data obtained from the boilers, which is put at 78.66KNM<sup>3</sup>/H.

The power calculation for the FDF motor at 55% VFD set point is as follows:

**i. Electric Power Calculation:**

$$P = 3 \times V \times I \times \cos\theta$$

Where  $\cos\theta = 0.85$ ,  $V=2837V$ , and  $I = 80.82A$ .

$$P=3 \times 2837 \times 80.82 \times 0.85=337.565 \text{ kW}$$

**ii. Energy Consumption:** The total power consumption for one hour is 337.565 kWh For 448 operational hours over 20 days, the

total energy consumed is:  
 $E = 337.565 \text{ kWh} \times 448 \text{ hours} = 151,229.12 \text{ kWh} \approx 151,229,120 \text{ Wh}$

- iii. **Cost Calculation:** N56.28 per kWh. Reference to PHED industrial area electricity tariff, 2023.:  
 Financial Cost =  $151,229.12 \text{ kWh} \times \text{N}56.28 = \text{N}8,511,174.87$

- iv. **Efficiency Calculation:** The efficiency  $\eta$  is calculated using:

$$\eta = \frac{dp \cdot Q}{\sqrt{3} \cdot V \cdot I \cdot \cos\theta} \times 100\%$$

Using the operating hour of boiler 1 with VFD which is 448 hours in 20 days, therefore, the FDF efficiency is calculated thus:

$$\eta = \frac{1 \times 79.62 \times 60 \times 60 \times 448}{151,229,120 \text{ Whr}} \times 100\%$$

$$\eta = 84.91\%$$

$$\eta \approx 85\%$$

Therefore, using the VDF, the FDF Motor efficiency is 85 % which is quite effective.

### C. Comparative Analysis

The energy and cost analysis for the four boilers as shown in Table 3 compared with existing control system (without VFD) to the VFD-controlled system.

**Table 3: Cost Comparison of Existing Control System vs. VFD Controlled System (for 20 days)**

Steams	Existing Control System (without VFD)		VFD Controlled System		Cost Saving (Naira)
	Energy demand (kWh)	Cost (Naira)	Energy demand (kWh)	Cost (Naira)	
Boiler 1	268,800	15,128,064	151,229.12	8,511,174.87	6,616,889.13
Boiler 2	264,600	14,891,688	148,866.17	8,378,187.77	6,531,500.23
Boiler 3	265,800	14,959,224	149,541.30	8,416,184.36	6,543,039.92
Boiler 4	265,200	14,925,456	149,203.73	8,397,185.92	6,528,270.08
<b>TOTAL</b>	<b>1,064,400</b>	<b>59,904,432</b>	<b>598,840.32</b>	<b>33,702,732.92</b>	<b>26,201,699.08</b>

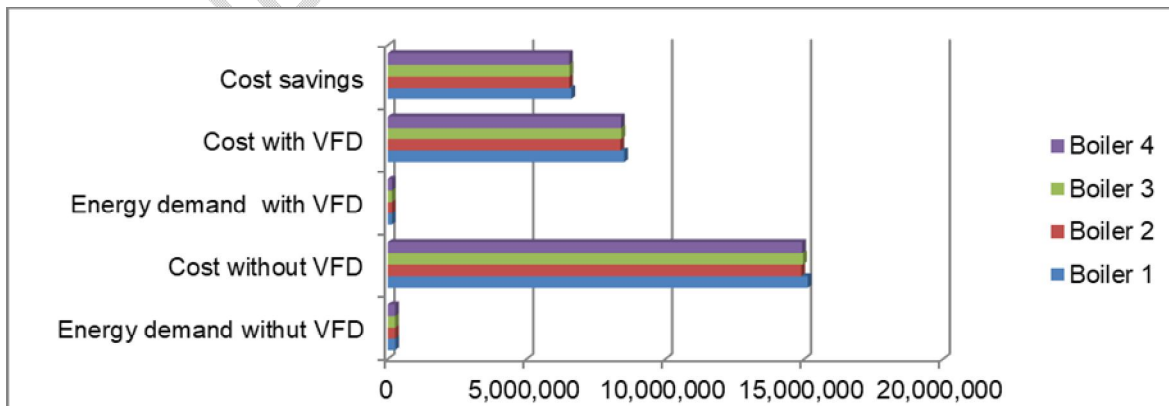

**Fig. 13: cost and energy comparative results of the boiler system with and without VFD control system**

### i. Annual Cost Savings

Assuming the conditions persist throughout the year, the annual cost saving is:

$$\text{Total Annual Savings} = 36520 \times 26,201,699.08 = \text{N}478,181,008.32$$

### ii. Cost of Implementing VFD Infrastructure

The cost breakdown for implementing the VFD infrastructure is as follows:

- 650 kW VFD units (4): N96,000,000
- Siemens Simatic S7-1200 PLC (4): N3,440,000
- Siemens KTP600 Basic Colour HMI (4): N6,400,000
- Input/Output Modules: N725,000
- Data Communication Cables: N175,000
- Installation and Programming: N3,500,000
- Miscellaneous Expenses: N1,200,000
- Total Cost: N111,440,000**

### iii. Payback Period for each of the boiler

The payback period for the VFD implementation is calculated using equation 6:

$$PL = (\text{Total Cost}) \div \left( \frac{N}{\text{yr}} \cdot \text{Savings} \right) \text{ per boiler} \quad (6)$$

Fig. 13 shows that the steam boiler airflow system has been successfully optimized through efficient method of controlling the speed of the force draft fan motor for energy cost savings and energy conservation.

## 5. CONCLUSION

The analysis of the steam boiler airflow control system at Port Harcourt Refining Company (PHRC) demonstrates significant improvements in cost and efficiency with the implementation of Variable Frequency Drive (VFD) technology.

The estimated annual cost for operating the four Forced Draft Fan (FDF) motors with the existing louvers damper system, without VFD, is approximately N1,093,255,884. In contrast, with VFD control, the total annual running cost is reduced to N615,074,875.79. This represents a substantial annual energy cost saving of N478,181,008.21, or a 43.8% reduction. The VFD technology effectively lowers energy consumption by reducing the rotational speed of the motors, thereby eliminating excess airflow and enhancing efficiency. Notably, the efficiency of the FDF motors improved from 47.7% to 85.0% with VFD control. This significant increase in motor efficiency is attributed to the use of motors with fewer poles—specifically, two-pole motors—which contribute to better speed control and performance. This research confirms that VFD technology is both energy-conservative and economically viable. For optimal motor speed control and improved efficiency in variable voltage applications, it is recommended to use electric motors with fewer poles. This approach contrasts with previous studies that reported lower efficiency improvements, highlighting the effectiveness of the two-pole motor configuration used in this study.

### DISCLAIMER (ARTIFICIAL INTELLIGENCE)

Author(s) hereby declare that NO generative AI technologies such as Large Language Models (ChatGPT, COPILOT, etc) and text-to-image generators have been used during writing or editing of manuscripts.

#### Disclaimer (Artificial intelligence)

##### Option 1:

Author(s) hereby declare that NO generative AI technologies such as Large Language Models (ChatGPT, COPILOT, etc.) and text-to-image generators have been used during the writing or editing of this manuscript.

##### Option 2:

Author(s) hereby declare that generative AI technologies such as Large Language Models, etc. have been used during the writing or editing of

manuscripts. This explanation will include the name, version, model, and source of the generative AI technology and as well as all input prompts provided to the generative AI technology

Details of the AI usage are given below:

- 1.
- 2.
- 3.

## REFERENCES

- [1] Smith, T., & Johnson, R. (2022). Advanced control systems for industrial steam boilers: Optimizing efficiency and emissions. *Journal of Power Systems Engineering*, 45(3), 215-230. <https://doi.org/10.1016/j.jpse.2022.04.001>
- [2] PHRC News, (2018). *A New dawn for PHRC Power Plant and utility*. PHRC NEWS, (4th Quarter), (p.12). <https://www.bpe.gov.ng/port-harcourt-refining-company-limited-phrc/>
- [3] Martinez, L., & Sanchez, R. (2017). Case study: Improving boiler efficiency in oil refineries through control system upgrades. *Energy Systems Engineering*, 15(3), 215-227. <https://doi.org/10.1016/j.eseng.2017.02.005>
- [4] Jones, K., & Patel, N. (2018). Impact of airflow control on combustion efficiency in industrial boilers. *Journal of Combustion Science*, 34(4), 321-330. <https://doi.org/10.1016/j.jcomsci.2018.09.007>
- [5] Rao, D., & Gupta, P. (2018). Environmental impact of industrial emissions from oil refinery boilers. *Journal of Environmental Engineering*, 44(1), 98-108. <https://doi.org/10.1016/j.jenveng.2018.06.002>
- [6] Pramono, M. W., Muhamad, H., and Arief, M. (2021). Energy saving analysis of air fan motor in power plant boiler controlled by variable frequency drive. *International Journal of Power Electronics and Drive Systems (IJPEDS)*, 12(4), 2059-2069. DOI: [10.11591/ijped.v12.i4.pp2059-2069](https://doi.org/10.11591/ijped.v12.i4.pp2059-2069)
- [7] Brown, A., & Green, M. (2019). Energy efficiency in industrial steam boilers: Challenges and solutions. *Energy Engineering*

Review, 12(2), 134-150.  
<https://doi.org/10.1016/j.eneng.2019.05.004>

- [8] Lin, Z., Huang, X., & Xu, Y. (2019). Artificial intelligence for optimizing combustion in steam boilers. *Journal of Applied Energy Research*, 45(5), 765-780.  
<https://doi.org/10.1016/j.jaer.2019.03.010>
- [9] Williams, D., & Clark, E. (2020). Modern challenges in steam boiler operation and control. *Journal of Energy Systems*, 23(9), 441-455. <https://doi.org/10.1016/j.jes.2020.07.013>
- [10] Zhang, T. (2020). Advanced optimization techniques for improving efficiency in industrial steam boilers. *Journal of Process Optimization*, 38(6), 643-656.  
<https://doi.org/10.1016/j.jpropt.2020.02.006>.
- [11] Kim, H., & Lee, J. (2021). Optimization of air-fuel ratio in industrial boilers using advanced control algorithms. *Control Engineering Journal*, 29(7), 587-598.  
<https://doi.org/10.1080/00207179.2021.1806193>
- [12] Chen, W., & Zhao, Q. (2021). Predictive control strategies for enhancing industrial boiler performance. *Journal of Process Control*, 58, 91-102. <https://doi.org/10.1016/j.jprocont.2020.11.003>
- [13] Yao, J., & Huang, S. (2022). Challenges and opportunities in the adoption of advanced control systems in oil refineries. *Refinery Engineering Journal*, 11(4), 299-310.  
<https://doi.org/10.1016/j.rej.2022.05.008>
- [14] Bandi, D., Madhu, L. N., Maddu, M. K., Pilli, P., Akkimsetti, S. (2020). Improving Thermal Power Plant Efficiency. *International Journal of recent Technology and Engineering (IJRTE)*. 8(6). 1265-1274
- [15] Omar, J. K., Firas, B. I., Thamir, K. I., Saiful, H. A. H. (2022). Energy and exergy analysis of the steam power plants: A comprehensive review on the Classification, Development, Improvements, and configurations. *Ain Shams Engineering Journal (science direct)*. 13 (3) 101640

UNDER PEER REVIEW