

## Original Research Article

# Thermo-structural Comparative Analysis of Internal Combustion Engine Piston by Finite Element Methods

### ABSTRACT

The piston is a "heart" of the engine and its working condition is the worst one of the key parts of the engine in the working environment. So, it is very important for structural analysis of the piston. This study analyses the piston to gain a result, which improves and optimizes the structure of the piston. Piston endures the cyclic gas pressure and the inertial forces at work, and this working condition may cause the fatigue damage of piston such as piston side wear, piston head cracks and the literature survey show that ideal piston consumes heat produced by burnt gases resulting in decrease of engine overall efficiency. One of the design criteria is the endeavour to reduce the structural weight and thus to reduce fuel consumption. This has been made possible by improved engine design. These improvements include increased use of lightweight materials, such as advanced ultrahigh tensile strength steels, aluminium and magnesium alloys, polymers, and carbon-fibre reinforced composite materials. Here the life of the piston is improved by means of introducing a new composite matrix of aluminium with particulates of silicon carbide which has the maximum wear factor and has the same performance except a little bit variation in properties reinforcement with Silicon carbide. The piston is designed and analysed through aluminium and silicon carbide in the ratio 2:3. A parametric model of a piston is done in 3D modeling software Solidworks and finite element analysis is used to calculate stresses, strains, deformations, temperature distributions and heat flux distribution by ANSYS software on piston and finally concluded the material which is the suitable for the internal combustion engine based on the results.

*Keywords: FEA, Piston, Al-6061, AlSiC-12*

### INTRODUCTION

Piston is considered as one of the most important parts in a reciprocating engine, reciprocating pumps, gas compressors and pneumatic cylinders, among other similar mechanisms in which it helps to convert the chemical energy obtained by the combustion of fuel into useful (work) mechanical power. The purpose of the piston is to provide a means of conveying the expansion of gases to the crankshaft via connecting rod, the piston acts as a movable end of the combustion chamber. Piston is essentially a cylindrical plug that moves up and down in the cylinder. It is equipped with piston rings to provide a good seal between the cylinder wall. Piston is one of the key components in an engine and it closely relates to the performance efficiency and carbon emissions. Pistons work in harsh condition and its reliability has become the key factors to improve engine reliability. They produce high stress and deformation due to

periodic load effect from high gas pressure, high speed reciprocating motion from the inertia force, lateral pressure, and friction. Burning of the high-pressure gas products at high temperature expands piston which produces thermal stress and deformation. Therefore, it is essential to analysis the thermal stress and strain, temperature fields, heat transfer, thermal and mechanical load coupling of the piston in order to improve the thermal stress distribution and improve its working reliability during the piston designed. In recent years, digital simulation technologies have been developing rapidly with the capability of simulating the product in the real-life environment. The results of these simulations are used to optimize design, in order to reduce the design cost and improve the quality of products. Recently, there has been studies to improve the working performance of internal combustion engine piston.

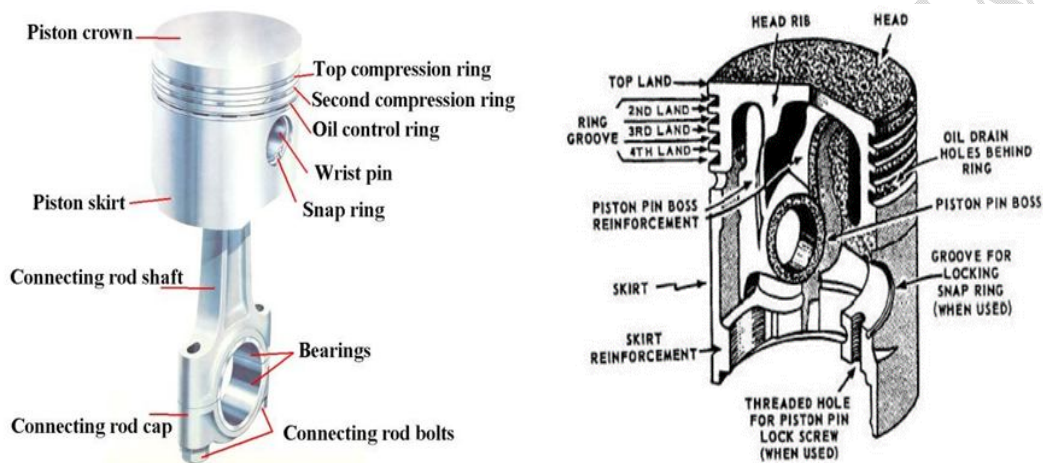

**Fig. 1. Simple construction of a piston (Manjunatha, 2013).**

Aluminium pistons can be either cast or forged. The forged piston is denser and forms a better heat path to allow the heat to get away from the piston head. It has a grain flow also that improves its wearing ability. The forged aluminium piston is also lighter in comparison with the cast iron piston. Thus, it produces lower inertia forces as it accelerates and decelerates in the cylinder. Lightness reduces the weight of the reciprocating masses and so enables higher engine speeds. Good heat conductivity reduces the risk of detonation so allowing a higher compression ratio.

Cast iron has been a universal material since early years because it possesses an excellent wearing quality, coefficient of expansion, and general suitability in manufacture. Due to the reduction of weight in reciprocating parts, the use of aluminium for piston has become essential. To obtain equal strength a greater thickness of metal is necessary, the advantage of the light metal is lost when this principle is used. Aluminium is inferior to cast iron in strength and wearing qualities, and its greater coefficient of expansion necessitates greater clearance in the cylinder to avoid the risk of seizure. The heat conductivity of aluminium is about three times that of cast iron, and this combined with the greater thickness necessary for strength, enables an aluminium alloy piston to run at much lower temperatures than a cast-iron one (200°C to 250°C as compared with 400° to 450°C)(Javidani & Larouche, 2014). As a result, carbonized oil does not form on the underside of the piston, and the crankcase, therefore, keeps cleaner(Koech, 2012). This cool-running property of aluminium is now recognized as being quite as valuable as its lightness, also pistons are sometimes made thicker than necessary for strength in order

to give improved cooling. The piston is subjected to highly rigorous conditions and must therefore have enormous strength and heat resistant properties to withstand high gas pressure. Its construction should be rigid enough to withstand thermal and mechanical distortion. To maintain piston temperature within limits, the heat from the crown of piston must be dissipated quickly and efficiently to the rings and bearing area and then to the cylinder walls. Numerous studies have been conducted to improve the design and material properties of the internal combustion engine piston.

Buyukkaya and Cerit (2007) also conducted thermal analyses on a conventional (uncoated) diesel piston, made of aluminium silicon alloy and steel. Secondly, thermal analyses are performed on pistons, coated with MgO–ZrO<sub>2</sub> material by means of using a commercial code, namely ANSYS. It has been shown that the maximum surface temperature of the coated piston with material which has low thermal conductivity is improved approximately 48% for the AISi alloy and 35% for the steel. Junju et al. (2012) investigated the effect of thermal barrier coatings on diesel engine performance his results indicate a reduction in fuel consumption and an improvement in the efficiency of the diesel engine. Durat et al. (2012) investigated the thermal barrier coating development for diesel engine aluminium piston and found that the resulting predicted temperatures and stresses on the piston, together with material strength information, the primary cause of coating failure is proposed to be low cycle fatigue resulting from localized yielding when the coating is hot and in compression. Srinadh and Rajasekhara (2015) investigated 1300cc diesel engine piston and piston rings using Pro/Engineer and ANSYS software to study the stress and displacement on cast iron, aluminium alloy A360 and Zamak by applying structural pressure. The thermal flux and temperature distribution are also analysed by applying temperatures on the piston surface in thermal analysis. Kumar (2016) conducted finite element analysis (FEA) of a four-stroke engine piston to compare aluminium alloy and Silicon carbide reinforced Zirconium diboride using CREO software for the model and ANSYS software for analysis. The study further analysed the natural frequency and Vibration mode of the piston and rings. Liu et al. (2024) conducted a finite element analysis of piston under thermal, mechanical and thermo-mechanical loads coupling by using the ANSYS software. By analysing the heat and force distributions on the piston, to determine the maximum stress concentration areas the results indicated that the highest temperature on the piston appears at the top of the combustion chamber bulge, where the deformations of the piston and combustion chamber are the most serious. Computer Aided Engineering Tools (CAET) propose the incredible benefit to enabling designers to consider virtually any modelling option without incurring the expensive actual manufacturing of the machine component. The ability to try new methodology on the computer concedes the chance to omitted the problems before production. Additionally, designers can easily and shortly identify the sensitivity of specific modeling parameters on the quality and production of the final part. The complex parts of the component can be simply simulated by computer aided engineering tools (CAET).

Due to improvements in IC engine power and performance, the pistons in the combustion chamber are subjected to increasingly higher thermal and mechanical loads. The cyclic changes in thermal and mechanical stresses seriously affect the piston fatigue life. Therefore, it is necessary to analyze the strength of the piston in the design process. The main purpose of the study is to model and simulate a three-dimensional internal combustion engine piston in Solidworks. Aluminium alloy (Al-6061) and Aluminium Silicon-Carbide (AlSiC-12) will be assigned to the designs and develop meshing and analysis

of piston in ANSYS Workbench 20.1 to determine various thermo-mechanical (structural) analysis variables like total deformation, directional deformations, equivalent elastic strain, equivalent Von Mises stress, Strain Energy, thermal Strain and factor of safety.

## 2. Material selection and process methodology

The most commonly used materials for pistons of I.C. engines are cast iron, cast aluminium, forged aluminium, titanium, cast steel and forged steel(Kumara & Charooa, 2024). The cast iron pistons are used for moderately rated engines with piston speeds below 6 m/s and aluminium alloy pistons are used for highly rated engines running at higher piston speeds(Al-Samarai & Al-Douri, 2024). It may be noted:

- i. The coefficient of thermal expansion for aluminium is about 2.5 times that of cast iron, therefore, a greater clearance must be provided between the piston and the cylinder wall in order to prevent seizing of the piston when engine runs continuously under heavy loads. But if excessive clearance is allowed, then the piston will develop 'piston slap' while it is cold and this tendency increases with wear. The less clearance between the piston and the cylinder wall will lead to seizing of piston.
- ii. The aluminium alloys used for pistons have high heat conductivity (nearly four times that of cast iron), therefore, these pistons ensure high rate of heat transfer and thus keeps down the maximum temperature difference between the centre and edges of the piston head or crown.
- iii. The aluminium alloys are about three times lighter than cast iron, therefore, its mechanical strength is good at low temperatures, but they lose their strength (about 50%) at temperatures above 325°C.

### 2.1. Aluminium alloy (AL-6061)

Aluminium /Aluminium alloys have high ductility and corrosion resistance. At sub-zero temperatures, their strength can be increased. However, their strength can be reduced at high temperatures of about 200-250°C hence the inclusion of titanium. Aluminium /Aluminium 6061 alloy is an age harden able alloy containing magnesium and copper. Table 1shows the chemical composition of Aluminium 6061 alloy.

**Table 1. Chemical compositions of AL-6061**

Element	Contents (%)
Aluminium	93.7
Copper, Cu	2.30
Magnesium, Mg	1.60
Iron, Fe	1.1
Nickel, Ni	1.0
Silicon, Si	0.18
Titanium, Ti	0.07

The physical and mechanical properties of the Aluminium alloy are tabulated in table 2.

**Table 2. Physical and mechanical properties of AL-6061**

Properties	Value (Metric)
Density	3.02 g/cm <sup>3</sup>
Melting point	6600C
Ultimate strength	330 MPa
Yield strength	370 MPa

Shear strength	260 MPa
Fatigue strength	125 MPa
Elastic modulus	70-80 GPa
Poisson's ratio	0.33
Elongation	10%

## 2.2. AISiC-12

AISiC-12 is a metal matrix composite consisting of aluminium matrix with silicon carbide particles. It has high thermal conductivity (180–200 W/m K), and its thermal expansion can be adjusted to match other materials e.g., silicon and gallium arsenide chips and various ceramics (Khan et al., 2024). AISiC-12 composites are suitable replacements for copper-molybdenum (CuMo) and copper-tungsten (CuW) alloys; they have about 1/3 the weight of copper, 1/5 of CuMo, and 1/6 of CuW, making them suitable for weight-sensitive applications; they are also stronger and stiffer than copper (Walser & Shields, 2007). The material is fully dense, without voids, and is hermetic. Its high stiffness and low-density suits larger parts with thin walls such as fins for heat dissipation. AISiC can be plated with nickel and other metals by thermal spraying. The aluminium matrix contains high number of dislocations, responsible for the strength of the material. The dislocations are introduced during cooling by the SiC particles, due to their different thermal expansion coefficient (Kustov et al., 2001). Table 3 shows the chemical composition of Aluminium 6061 alloy.

**Table3. Chemical compositions of AISiC-12**

Element (AISiC-12)	Contents (%)
Aluminium	56.2
Copper, Cu	0.07
Magnesium, Mg	0.3
Iron, Fe	0.46
Nickel, Ni	0.03
Silicon, Si	30.3
Titanium, Ti	0.37
Carbide, C	12.3

The physical and mechanical properties of the AISiC-12 are tabulated in Table 4.

**Table4. Physical and mechanical properties of AISiC-12**

Properties	Value
Density	2.89 g/cm <sup>3</sup>
Melting point	722 <sup>0</sup> C
Ultimate strength	341 MPa
Yield strength	427 MPa
Shear strength	287 MPa
Fatigue strength	141 MPa
Elastic modulus	167 GPa

Poisson's ratio	0.25
Elongation	5.4%
Flexural strength	450 MPa
Thermal conductivity	170–180 W/m K

### 2.3. Model assumptions and process

Numerical modeling assumptions are crucial for simplifying complex systems, making computations feasible, and focusing on key variables. They help reduce the computational burden, ensure models are analytically tractable, and align models with available data for validation. Assumptions also define the scope of the model by setting boundary and initial conditions, while managing uncertainties and unknowns, ensuring that the model remains practical, relevant, and applicable to real-world scenarios.

#### 2.3.1. The model assumptions

1. The piston material is considered as homogeneous and isotropic.
2. Inertia and body force effects are negligible during the analysis.
3. The piston is stress free before the application of analysis.
4. Only ambient air-cooling is considered and no forced convection is taken.
5. The thermal conductivity of the material used for the analysis is uniform throughout.
6. The specific heat of the materials used are constant throughout and does not change with temperature.

#### 2.3.2. Model process

The geometrical 3D model was created in Solidworks and then exported to ANSYS for pre-processing. Pre-processing of model consist of meshing, selection of material properties, creation of load collectors and apply boundary conditions on model.

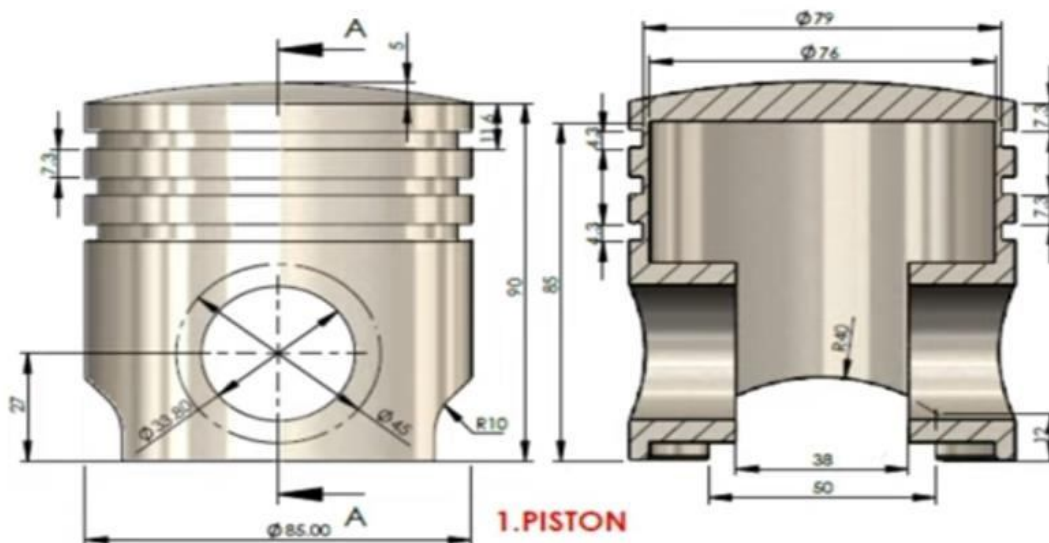

Fig. 2. Basic dimensions of the piston.

#### 2.3.3. Model design considerations

In designing the piston, the following points were taken into consideration:

- i. Strength to withstand the high pressure.
- ii. Minimum weight to withstand the inertia forces.
- iii. Effective oil sealing in the cylinder.
- iv. Sufficient bearing area to prevent undue wear.
- v. High speed reciprocation without noise.
- vi. Sufficient rigid construction to withstand thermal and mechanical distortions.
- vii. Sufficient support for the piston pin.

Solidworks software was used to model the piston considering the symmetry of the piston geometry structure and adopt one-half model to analyse the piston, which can simplify the calculation process of finite element, shorten the time of analysis and also can get a good analysis result.

#### 2.4 Specification of the Engine

A piston of 150 cc engine was considered with the specifications stated in Table 5:

**Table 5. Engine specifications**

Engine Type	Air Cooled 4-Stroke
Bore x Stroke (mm)	57x58.6
Displacement	785
Maximum Power	13.8 bhp at 8500rpm
Maximum Torque	13.4 Nm at 6000rpm
Compression Ratio	9.35/1

Theoretical designing of piston was done using standard design procedure and the selected parameters are listed in Table 6.

**Table 6. Piston specifications**

Parts of the Piston	Measurement (Quantity)
Thickness of the piston head	7.31mm
Radial thickness of piston ring	2 mm
Axial thickness of piston ring	1.6 mm
Number of piston rings	4
Width of top land	8.04 mm
Width of ring land	1.28 mm
Radial depth of piston ring groove	2.4 mm
Thickness of piston barrel at top end	8.61 mm
Thickness of piston barrel at open end	1.827 mm
Piston pin diameter	17.1 mm
Diameter of piston boss	30.62 mm
Length of skirt	34.2 mm
Total length of piston	52.48 mm

#### 2.5. Finite element method

The Basic concept in FEA is that the structure is divided into smaller elements of finite dimensions called finite elements. The original structure is then considered as an assemblage of these elements connected at a finite number of joints called nodes. Simple functions are chosen to approximate the displacements over each finite element. This will represent the displacement within the element in terms of the displacement at the nodes of the element. The finite element method is a mathematical tool for solving ordinary and partial differential equations and has the ability to solve the complex problems that can be represented in differential equations form. Ansys mechanical software was selected to perform the analytical task due to its ability to handle both linear and non-linearities associated with the design.

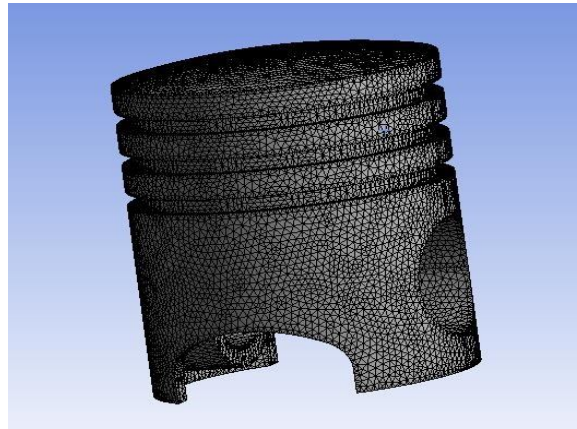

**Fig. 3.Mesh: nodes:188577 element:105885**

### **2.5.1 Boundary conditions for structural analysis**

A static analysis calculates the effects of steady loading conditions on a structure, while ignoring inertia and damping effects, such as those caused by time varying loads. A static analysis can, however, include steady inertia loads (such as gravity and rotational velocity), and time-varying loads that can be approximated as static equivalent loads. Static analysis determines the displacements, stresses, strains, and forces in structures or components caused by loads that do not induce significant inertia and damping effects. Steady loading and response conditions are assumed; that is, the loads and the structure's response are assumed to vary slowly with respect to time. The types of loading that can be applied in a static analysis include:

- i. Externally applied forces and pressures
- ii. Steady-state inertial forces
- iii. Imposed (non-zero) displacements
- iv. Flouces (for nuclear swelling)

Combustion of gases in the combustion chamber exerts pressure on the head of the piston during power stroke. Fixed support was given at surface of pin hole. The piston moves from top dead centre (TDC) to bottom dead centre (BDC) with the help of fixed support at pin hole and the pressure acting on piston is  $4 \text{ N/mm}^2$ .

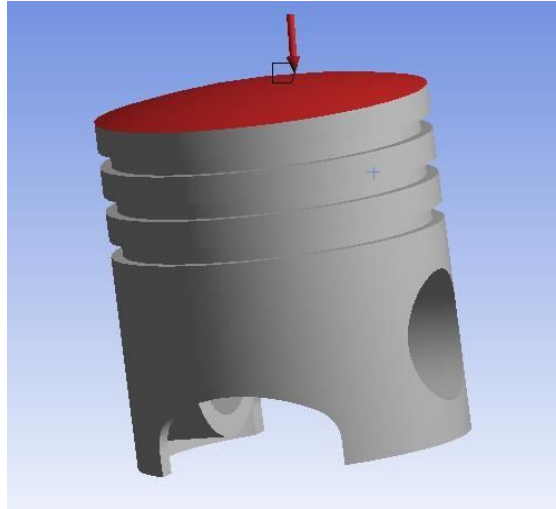

**Fig. 4. Structural boundary condition (Pressure)**

### 2.5.2. Boundary condition for thermal analysis

The thermal boundary conditions consist of applying a convection heat transfer coefficient and the bulk temperature, and they are applied to the piston crown, land sides, piston skirt. The upper surface of the piston is subjected to hot gases which take different values of temperature of gases and convective heat transfer coefficient for the different crank angles. The thermal boundary conditions for the current study is presented in Table 7.

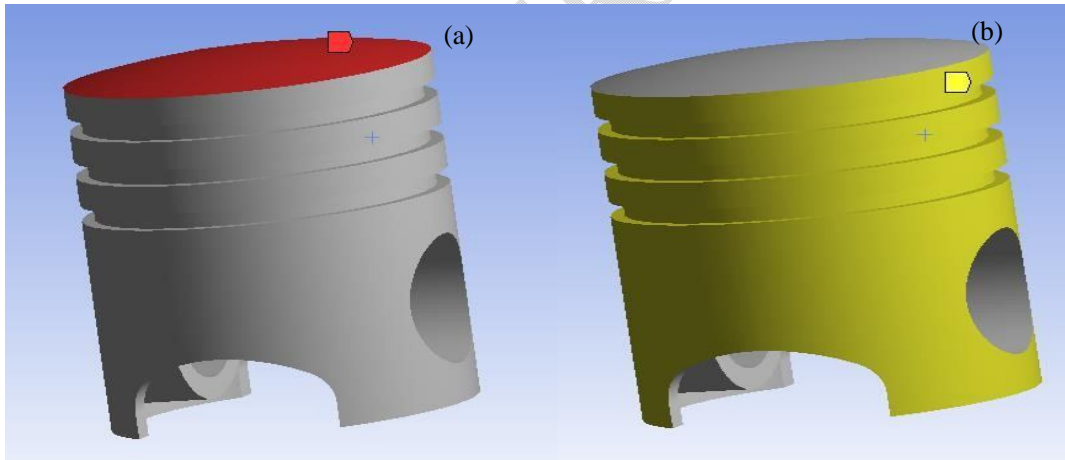

**Fig.5. Thermal boundary conditions: (a) temperature and (b) convection of the material**

**Table 7. Thermal boundary conditions of the piston.**

Variable	Quantity
Maximum on piston head temperature	573 <sup>0</sup> K
Bulk temperature	498 <sup>0</sup> K
Heat transfer coefficient on piston surface	3200 W/m <sup>2</sup> K
Maximum temperature at edges of piston	513 <sup>0</sup> K
Heat transfer coefficient on edge piston	2400 W/m <sup>2</sup> K
Heat transfer coefficient on lands rings	1600 W/m <sup>2</sup> K
Heat transfer coefficient on piston skirt	1000 W/m <sup>2</sup> K

Temperature level of piston ring	493 <sup>0</sup> K
Temperature level of piston skirt	463 <sup>0</sup> K
Temperature level of piston bottom portion	343 <sup>0</sup> K

### 3. Results

The dynamics of the whole piston in the form of input temperature and pressure will be considered and then thermo-structural analysis of both models will be presented. Two models with the same input parameters and control schemes but different materials assignment is developed for the study. A model scalar of 1:1 is applied to obtain equal order models that are suitable for real life dynamic analysis and control design. The measuring variables analysed in the current are the total deformations, directional deformations, strain energy, thermal strain, stresses, strains and factor of safety.

#### 3.1 Thermo-structural analysis

##### 3.1.1 Total deformation and directional deformations in X-Y-Z axis

The three-dimensional finite element model was analysed using the Ansys mechanical commercial code to determine the total deformation and directional deformations of both models; the analysis was performed in two parts: (1) steady state thermal (i.e., heat transfer) solution was obtained generating the nodal temperatures and (2) static structural solution was obtained by imposing the nodal temperatures and the pressure loads. The resultant out-of-plane varying deformations of the whole surfaces of heat pistons are shown in Fig. 6 and Fig. 7. The deformations were calculated relative to the centre point of the full dome top. These plots indicate a measurable hump (or a deflection peak) located around the rim on the plane of symmetry. According to Fig. 6 and 7 there is a high deformation around the fit rim and the ring grooves. As a general mechanical design principle, more grooves in the body will decrease the mechanical strength of any design.

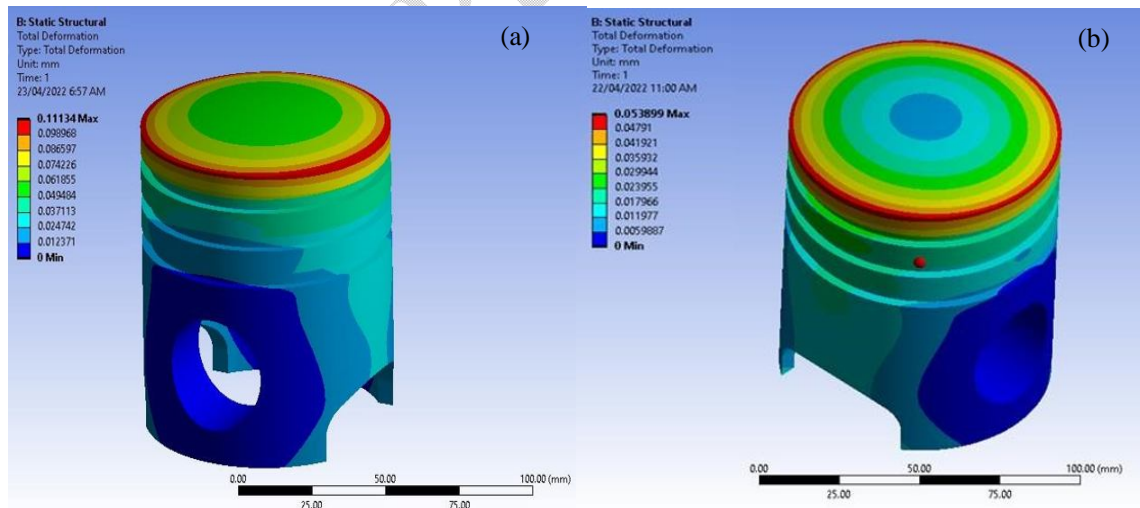

Fig. 6. Total deformation of (a) Al6061 and (b) AISiC

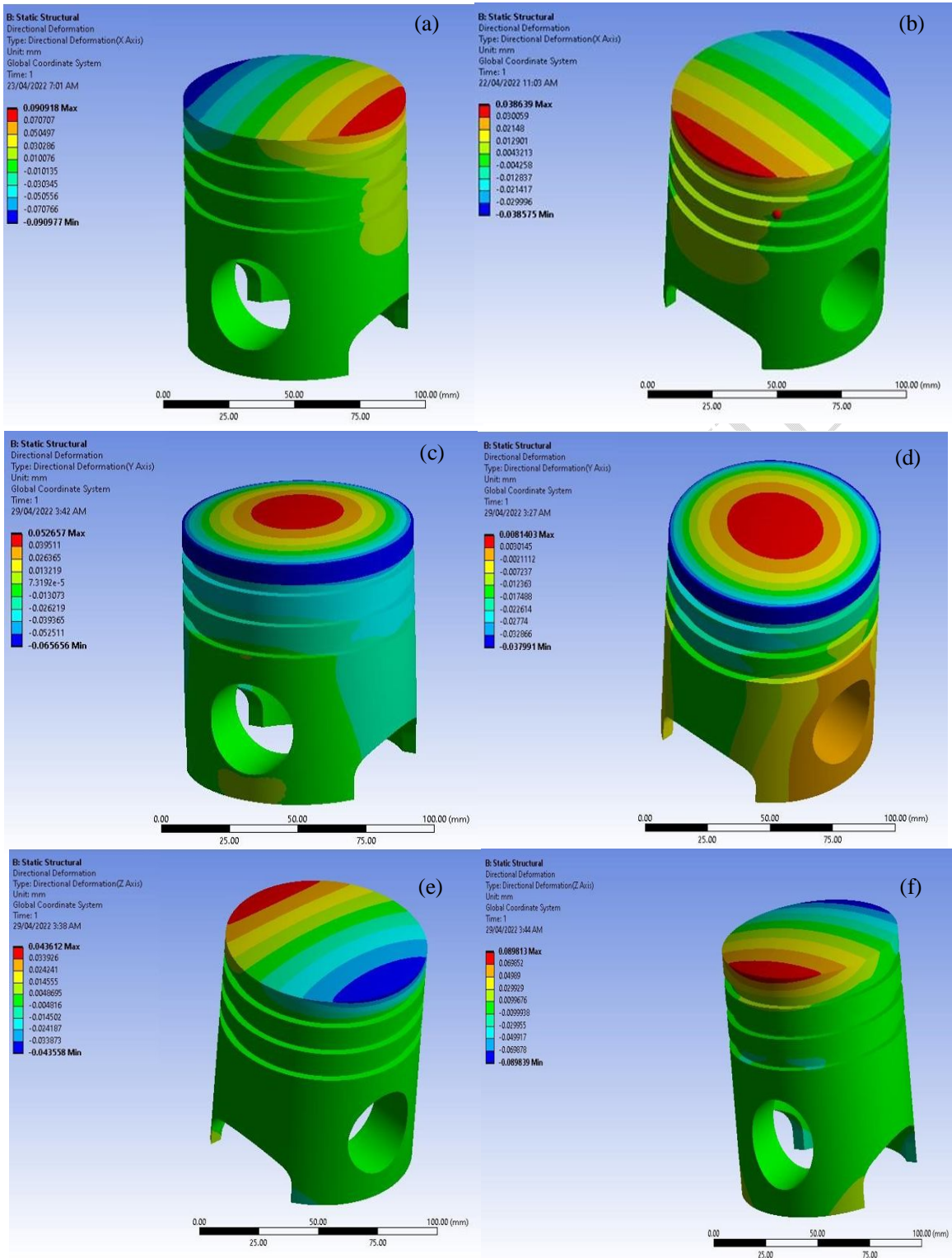
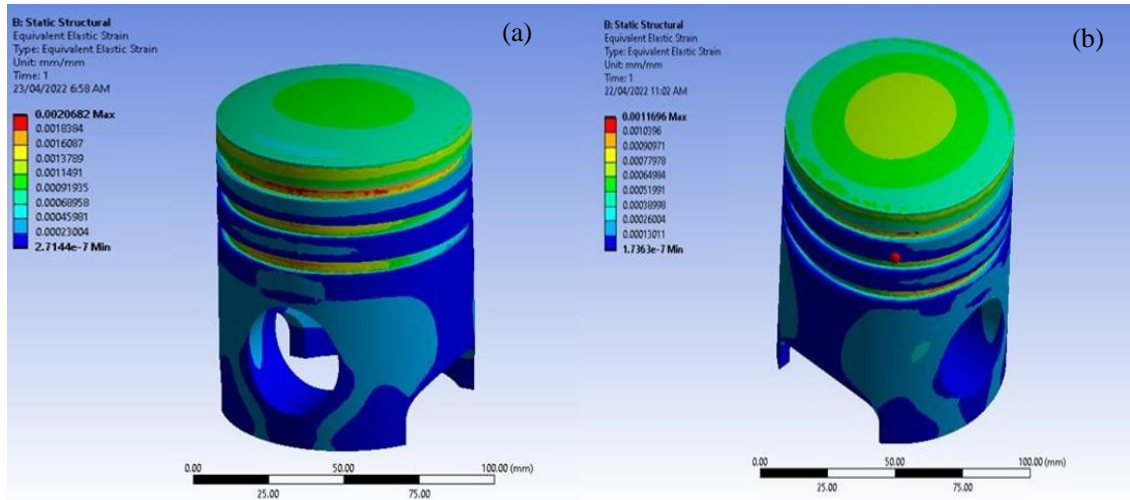

Fig. 7. Directional deformation (X-Y-Z-Axis) of (a, c, e) Al6061 and (b, d, f) AISiC

### 3.2 Elastic strain analysis

Fig. 8 (a) and (b) present the piston equivalent strain (von mises) distributions of Al6061 and AISiC respectively. The high temperature area near the apex of the piston dome had a large expansion, and it

gradually decreased away to the rim. The equivalent strain distributions showed similar distributions amongst both designs. The maximum equivalent strain value for Al6061 and AISiC were discovered to be  $2.0682e-003$  and  $1.1696e-003$  respectively for the given loading condition. It was observed that the equivalent elastic strain in both models was more pronounced at the piston rings groove.



**Fig. 8. Equivalent elastic strain of (a) Al6061 and (b) AISiC**

### 3.3. Stress distribution

Fig.9(a) and (b) are the results of the Von Mises stresses of Al6061 and AISiC. The maximum stresses were found around the ring grooves and the rim stretch where there is concentration of both pressure and temperature in both cases. The pistons maximum local von-Mises stresses values were 146.68 and 128.61 for both thermal and pressure loading cases for Al6061 and AISiC respectively. These figures confirmed that these stress values are lower than the allowable stress values for normal plunger piston. The sum of the membrane stress was 162 MPa, which is lower than the constraint value ( $1.5 \times$  allowable stress value). Therefore, the stress state of the piston satisfied the International Automobile Standard (IAS) criteria (Altshuler, 1984).

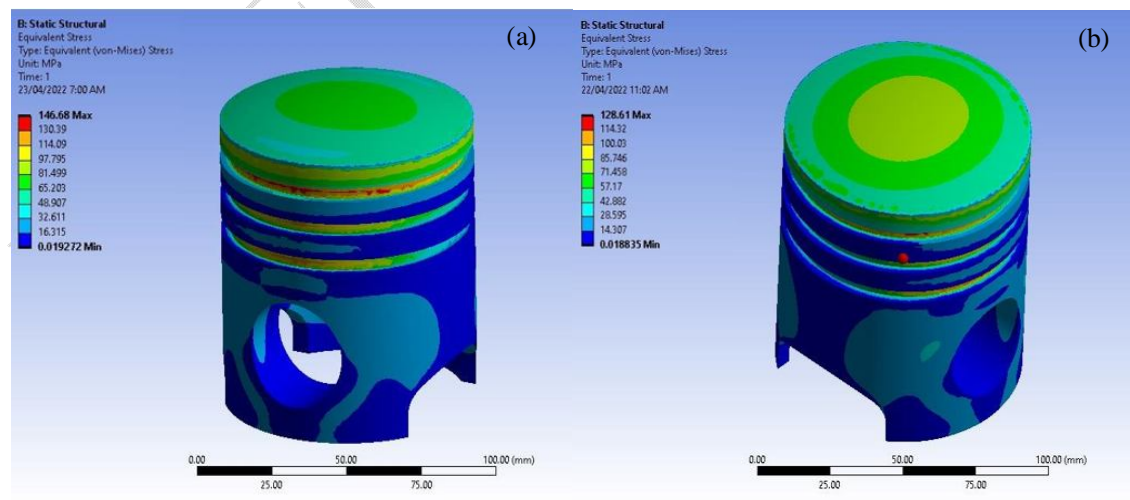

**Fig. 9. Equivalent (Von-Mises) stress of (a) Al6061 and (b) AISiC**

### 3.4. Strain energy

The strain energy being the energy stored in the piston due to all direction deformations, appeared scattered in the ring grooves and the dome surface with maximum matrix value of  $0.13864\text{m}^3$  and  $0.098008\text{m}^3$  for Al6061 and AISiC models respectively as presented in Fig. 10 (a) and (b).

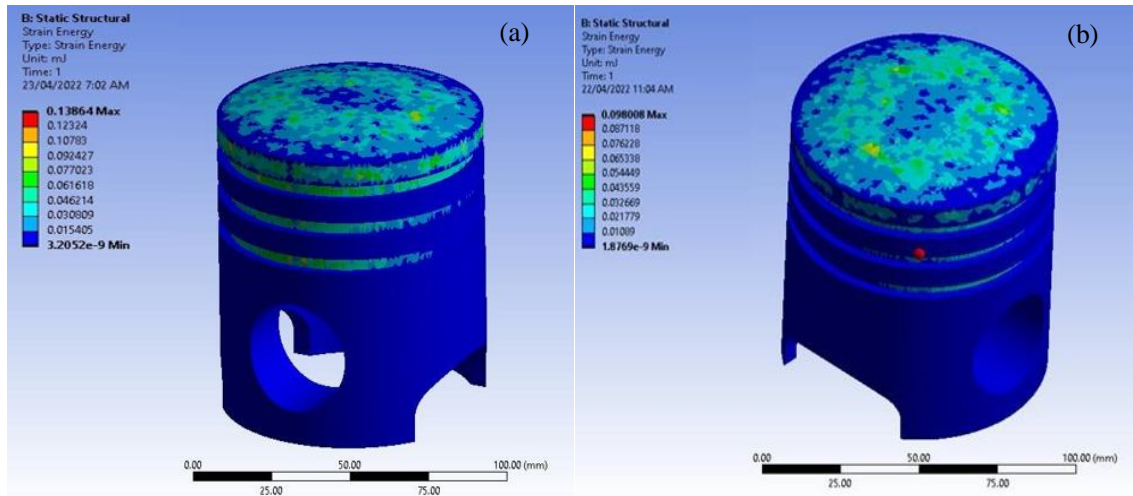

Fig. 10. Strain energy of (a) Al6061 and (b) AISiC

### 3.5. Thermal strain

Fig.11 shows thermal strain levels in Al6061 and AISiC piston. The maximum thermal strains for Al6061 and AISiC models are  $0.0030605\text{mm/mm}$  and  $0.0014879\text{ mm/mm}$  respectively. As comparing the Al6061 and AISiC materials the maximum thermal strain value is decreased in AISiC material by  $0.0015726\text{ mm/mm}$ .

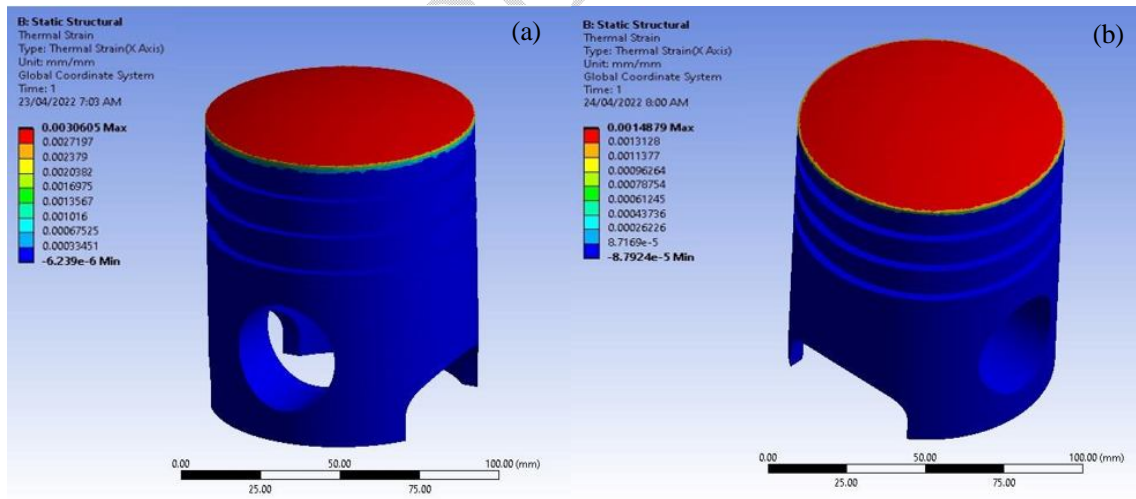
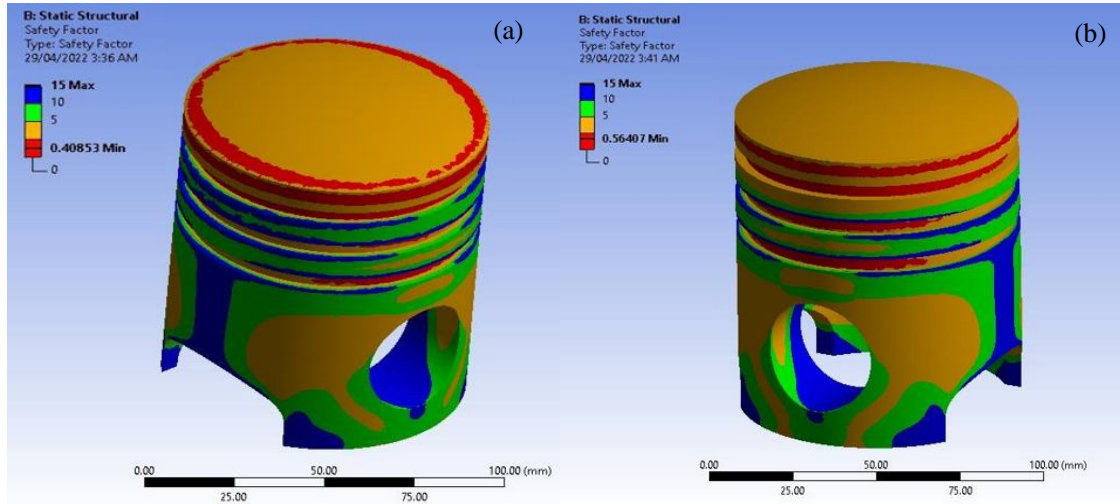

Fig. 11. Thermal strain of Al6061 and AISiC

### 3.6. Factor of safety (FOS)

Fig.12 (a) and (b) present the maximum damage and failure concentration areas as observed in the Al6061 and AISiC models. As expected highest failure zone is observed at the top brim and inside of the ring grooves of the pistons where the FOS are  $0.40853$  and  $0.564$  nearing zero for Al6061 and AISiC models, due to the concentration of high temperatures and pressures around these areas.

Generally, the theoretical FOS of the plunger piston for an internal combustion engine is 5.9 (Sterling, 1917). The maximum generated FOS of both models have magnitude of 15. The maximum FOS was observed to be more profound at the skirt of the models. The theoretical FOS value of 5.9 is within the range of factor of safeties of both models of the current models generated. Therefore, both models are very safe.



**Fig. 12. Factor of Safety of (a) Al6061 and (b) AlSiC**

#### 4. Discussions

The Table 8 display predicted simulated result for aluminium alloy Al6061 and aluminium silicon carbide (AlSiC) piston models for four-cylinder IC engine. The variables analysed are the total deformations, directional deformations, strain energy, thermal strain, stresses, strains and factor of safety and comparison is done for the selected materials. The focus here is on the performance of the components so with Al6061 having a high stress value means AlSiC can give a high performance and long operating duration under the same operating conditions, in comparison with Al6061. AlSiC is suggested as a possible alternative material for piston with moderate temperature because it will provide high strength to weight ratio. As the effect of strain energy density on the mechanical behaviour of the material can be significant. The change in strain energy density for deformations out of the residually stressed configuration that quantify the contribution of a residual stress to the mechanical behaviour of the elasticity of the materials, residual stress field and the mechanical response were examine in relation to the directional deformations. The change in strain energy density at any axial point of all the three directional deformation was measured to the extent at which the material at that point is loaded or unloaded by a deformation. Due to the strain energy density values obtained which shows slight difference between the two materials, though Al6061 value is high its weight can compensate for the energy-mass ratio. The low strain energy for AlSiC can be used in conjunction with the stress and strain fields to develop a clear physical interpretation of the universal mechanical behaviour of a residually stressed of the material. These value of AlSiC in the presence of the residual stress field and equivalent stress-free body under all of the deformations has the effect of making the body more compliant than the Al6061.

In a way to validate the results obtained from the finite element analysis, the experimental weighing results of grey cast iron piston were compared. The weights of the two models were compared with Chilled grey cast iron using the ANSYS mechanical mass calculator, the AISiC-12 model weighed 0.286kg representing 26% while the AL-6061 model weight 0.795kg representing 74%. With the weight variations indicating light weight ratio in favour of AISiC-12 makes it more efficient mechanically. Hence, the main objective of using AISiC-12 alloy to design piston of internal combustion engine for weight reduction has been achieved.

**Table 8. Summary of the measuring variables**

Parameter	Al6061		AISiC	
	Maximum	Minimum	Maximum	Minimum
Total Deformation (mm)	11134e-1	0	5.3899e-2	0
Directional Deformation X (mm)	7.0707e-2	-9.0977e-2	3.0059e-2	-3.8575e-2
Directional Deformation Y (mm)	5.2657e-2	-6.5656e-2	8.1403e-3	-3.7991e-2
Directional Deformation Z (mm)	8.9813e-2	-8.9839e-2	4.3612e-2	-4.3558e-2
Elastic Strain (mm/mm)	2.0682e-3	2.7144e-7	1.1696e-3	1.7363e-7
Von Mises Stress (MPa)	146.68	1.9272e-2	128.61	1.8835e-2
Strain Energy (MJ)	1.3864e-1	3.2052e-9	0.098008	1.8769e-9
Thermal Strain (mm/mm)	3.0605e-3	-6.2390e-6	1.4879e-3	-8.7924e-5
Factor of Safety	15	4.0853e-1	15	5.6407e-1

#### 4.1 Modal analysis

The modal analysis presented the natural incidence deformation in relation to equivalent stress and equivalent strain of the both models at different modes for all the selected materials. Incidence range of the AISiC shows a very good match with the incidence range of Al6061 and better than chilled grey cast iron used as the base standard material for plunger pistons. The obtained incidence range of the existing material piston was 6199.8 Hz to 6893.2 Hz and for modified material was 8016.8 Hz to 8932.1 Hz. As the incidence range of the modified piston is within the incidence range of existing piston, the modified design proves to be safe. The total deformation of AISiC is less compared to Al6061. This indicates change of the Al6061 piston to AISiC piston results in high incidence range due to lowest weight value and the deformation close to the existing piston material under the same operating conditions. The strain value of AISiC is low compared to Al6061 which is close and at the same time deformation in both materials are less than standard deformation bridge for non-static IC engines components.

**Table 9. Incidence range against deformation with different modes of Al6061 Piston**

Mode	Deformation	Incidence range (Hz)
1	11134e-1	6199.8
2	16174e-1	6215.3
3	2.0416e-1	6480.0
4	2.6544e-1	6497.0
5	2.9231e-1	6870.8

6	3.1634e-1	6893.2
---	-----------	--------

**Table 10. Incidence range against deformation with different modes of AISiCPiston**

Mode	Deformation	Incidence range (Hz)
1	5.3899e-2	8016.8
2	6.4023e-2	8136.8
3	7.3893e-2	8327.9
4	8.4153e-2	8536.5
5	8.6304e-2	8737.6
6	9.3129e-2	8932.1

## 5. Conclusion

This study considered two analytical methods which are static structural and thermal analysis. The parameters considered under the thermo-static (thermal-structural) analysis were total deformation, directional deformations, equivalent elastic strain, equivalent Von Mises stress, Strain Energy, thermal Strain and factor of safety of Al6061 and AISiC-12. The following conclusions were made from the study into modelling and simulation of the piston of an internal combustion engine using AL-6061 and AISiC-12.

It was revealed from the study that when the structural load of 49637.2N and thermal load of 324°C were imposed on the piston of the AISiC-12 and AL-6061 and their deformations compared, their maximum deformations were 5.389e-2 mm and 9.896e2 mm respectively. The comparison showed that AISiC-12 piston deformed less in relation to the two selected materials, though both materials were within the percentage reductions of the materials hence all the pistons were found to be satisfactory.

Moreover, when the equivalent elastic strains of the pistons were compared, it was revealed that, the maximum and minimum elastic strain of the AISiC-12 piston was 1.169e-3 and 1.736e-7 respectively while the maximum and minimum elastic strain of Al-6061 was 2.068e-3 and 2.714e-7 respectively.

The maximum Von Mises stresses induced in AISiC-12 and Al-6061 piston was 126.61MPa and 146.68MPa respectively. The observation from the data showed that, the Mises stresses induced in both pistons were below the compressive yield strengths of the individual materials, hence the pistons can withstand the load imposed.

When the factor of safeties of the pistons were compared, it was found that the AISiC12 piston has high minimum value than Al-6061 which makes it more suitable material in terms of failure as against Al-6061 with a low minimum safety factor of 0.40853 as against 0.56407 for AISiC-12.

## Reference

- Al-Samarai, R. A., & Al-Douri, Y. (2024). *Wear in Metals*. In *Friction and Wear in Metals* (pp. 61-105). Springer.
- Altshuler, A. A. (1984). *The future of the automobile: the report of MIT's international automobile program*. MIT press.

- Buyukkaya, E., & Cerit, M. (2007). Thermal analysis of a ceramic coating diesel engine piston using 3-D finite element method. *Surface and coatings technology*, 202(2), 398-402.
- Durat, M., Kapsiz, M., Nart, E., Ficici, F., & Parlak, A. (2012). The effects of coating materials in spark ignition engine design. *Materials & Design (1980-2015)*, 36, 540-545.
- Javidani, M., & Larouche, D. (2014). Application of cast Al–Si alloys in internal combustion engine components. *International Materials Reviews*, 59(3), 132-158.
- Junju, V., Mallikarjun, M., & Mamilla, V. R. (2012). Thermo mechanical analysis of diesel engine piston using ceramic crown. *International Journal of Emerging trends in Engineering and Development*, 5(2), 22-29.
- Khan, S. N., Usman, A., Afzal, M. S., Tanveer, M., Liwicki, M., Almqvist, A., & Park, C. W. (2024). Numerical investigation of thermomechanical behavior of Yttrium barium zirconate-coated aluminum alloy piston in an internal combustion engine. *Applied Thermal Engineering*, 236, 121603.
- Koesh, P. K. (2012). *A study on the effects of iron on microstructure and mechanical properties of Aluminium-Silicon alloys* University of Nairobi, Kenya].
- Kumar, K. S. (2016). Design and analysis of IC engine piston and piston-ring on composite material using Creo and Ansys software. *Journal of Engineering and Science*, 1(1), 39-51.
- Kumara, S., & Charooa, M. (2024). Evaluation of Tribological Properties of Different Coatings on Automotive Piston Rings: A Review. *Journal of Materials*, 2(4), 288-302.
- Kustov, S., Golyandin, S., Sapozhnikov, K., Vincent, A., Maire, E., & Lormand, G. (2001). Structural and transient internal friction due to thermal expansion mismatch between matrix and reinforcement in Al–SiC particulate composite. *Materials Science and Engineering: A*, 313(1-2), 218-226.
- Liu, B., Aggarwal, S. K., Zhang, s., Tchakam, H. U., & Luo, H. (2024). Thermo-mechanical coupling strength analysis of a diesel engine piston based on finite element method. *International Journal of Green Energy*, 21(4), 732-744.
- Manjunatha, D. (2013). TR, HV Prabhunand GR, Chavhan" Design and Static Structural Analysis of Cylinder and Piston of Two Stage Reciprocating Compressors Using ANSYS,". *International Journal of Innovative Research in Science, Engineering and Technology (An ISO 3297: 2007 Certified Organization)*, vol, 2, 7.
- Srinadh, M., & Rajasekhara, K. (2015). Static and thermal analysis of piston and piston rings. *International Journal of Engineering Technology, Management and Applied Sciences*, 3(8), 51-58.
- Sterling, F. W. (1917). *Internal Combustion Engine Manual*. Bereford, printer.
- Walser, H., & Shields, J. A. (2007). Traditional and emerging applications of molybdenum metal and its alloys. *International Molybdenum Association, IMO A Newsletter*, 1, 16.