

INVESTIGATION OF DEVICES FOR MEASURING THE QUALITY OF ELECTRICAL ENERGY

Abstract. Electric energy is the most mass product, as well as the most widely consumed type of energy both in industry and in everyday life. In a modern market economy, it is necessary to improve the quality of manufactured products, including the economical use of fuel and energy resources, the economical use of financial resources, and increased efficiency. One of the parameters of electricity standardized by standards is voltage. The article presents deterministic and statistical methods for determining voltage deviation.

Also, a virtual instrument is studied. When measuring with a virtual method, corrective filtration of electrical energy was introduced in each measurement link. This method reduces energy losses, which means that the deviation during transformation does not increase.

Keywords: electric energy, quality energy, statistical methods, voltage deviation, deterministic methods.

INTRODUCTION

The current stage of the development of human society is characterized by the wide application of high-tech, energy-efficient production sites and technologies. At the same time, the automation of production, the wide application of flexible automatic production, computer-controlled machines and industrial robots require the solution of a number of problems in these and other fields. This is, first of all, the problem of energy, which is the main problem of the modern world. According to world scientists, this problem will be the main problem of the 21st century. Energy sources currently produced and used are divided into two parts: natural and artificial energy sources. Natural energy sources include, first of all, sun, wind, water (thermal waters), etc. belongs to Artificial energy sources include various nuclear, water, thermal power stations, certain engines, generators, batteries, etc. created and used as a result of human activity. The use of both sources requires solving a number of technical, economic and environmental issues. Along with these, the care and use of the received energy has created a number of difficulties. It is for this reason that various scientific centers of the world, construction and design problems, scientific and educational institutions, universities and others are seriously dealing with all these problems.

The current market economy, along with all this, requires increasing production efficiency, rational use of material resources, including rational use of fuel and energy resources, and improving the quality of the manufactured product[1-5]. It should also be noted that 70-80% of the energy used in the world is accounted for by electricity. First of all, this is related to the fact that the acquisition, maintenance and use of electricity is superior to other types of energy, and on the other hand, various energies (mechanical, light, heat, chemical, etc.) are easily converted into electrical energy and vice versa. However, the quality of electric power has a significant impact on the reliability and economic indicators of electric grids and industrial enterprises[6]. Thus, low-quality electricity leads to the production of waste products in large quantities, as well as the breakdown of valuable technological equipment and the occurrence of other serious accidents. At the same time, the wide

distribution of electricity receivers and processors with non-linear characteristics, non-symmetrical and jumpy modes of operation has a negative impact on the quality of electric power, and thus we have raised the issue of increasing the quality of electric power to the list of issues of crucial importance for the national economy [7, 9]. All of these impose very serious requirements on the quality of electric power, and these requirements are first of all related to the tendency (spread) of the voltage, non-symmetry and non-sinusoidality of the voltage, which are the main quality indicators of the electric power [10-14]. Considering this point, the requirements of DIST 13109-17 operating in our republic must be ensured during the design and operation of electric grids. For this, the effectiveness of the measures taken by various project and operational enterprises should be checked with the reports of various quality indicators of electric energy. In the design of electric grids, it is foreseen that there will be future facilities that can normalize the quality of electric power, which in turn requires the expenditure of additional material and capital resources. The selection of the necessary mechanical means for this requires the preparation of an appropriate technical and economic report [17,18].

All this requires the solution of a new problem - the problem of control over the quality indicators of electric power in operational conditions. The solution to this problem does not end with the design and application of the control system for the quality indicators of electric power, it requires the solution of a number of organizational and technical issues. In addition, devices of suitable size according to accuracy class and acceleration ability, size range should be used. These once again confirm the importance of the accuracy of measurement result values for energy quality management, in other words, the correct information necessary for management [19,20].

Among the parameters of the quality of electricity, one of the parameters standardized by the standard is the relatively slow change - tendency of the voltage. The methods of determining the inclination of the movement in the emission work by deterministic and probabilistic-static methods are given.

STATISTICAL ANALYZER OF THE QUALITY OF EDUCATION

One of the most appropriate devices used for control and analysis of quality of service is a statistical analyzer of quality of service. The statistical analyzer of alertness quality is for comparing histograms of alertness parameters. For this purpose, the entire size range of the deviation parameters is divided into several levels, each of which has a width of B . The statistical analyzer of the quality of the signal is a multi-channel device, the number of its channels corresponds to the number of degrees of the histogram. The device notes every time the deviation values fall to the given levels for the entire measurement period and stores it in pulse counters for a long time [15]. After that, according to the results of these comparisons, the probability of the deviation values falling into each of these given levels is determined.

The structural scheme of the statistical analyzer of the quality of data is given in Figure 1. It consists of an amplifier measuring device, a calibrated input device (CID), a multi-channel analog switch (MCAS), a multi-channel digital switch (MCDS), a metering unit and a management unit [16]. The control unit has a special automatic circuit and a timer (time element), which switches the measuring device from one level of the measured deviation to another. At the same time, the output pulse counters, each of which corresponds to the level of a hundred size deviations, are also switched. Each of the trip levels correspond to the levels of the histograms and are established using a calibrated matrix of plug contacts in the

input device. The automation circuit in the control unit is designed so that a digital pulse sensor is always used so that its size corresponds to the frequency observed in it.

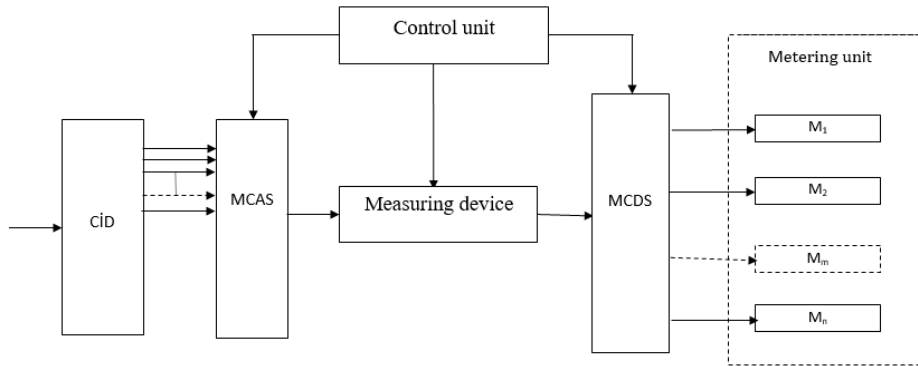

Figure 1. The structural scheme of the statistical analyzer of the quality of data
 CID - calibrated input device, MCAS - multi-channel analog switch,
 MCDS - multi-channel digital switch, M₁, M_n - counters

Measurements are carried out periodically, and their periodicity is determined with the help of a relaxation time element - a timer. As a result of the search, the following distribution is obtained:

Diameters B₂ - B₁ B₃ - B₂ B₄ - B₃ ... B_{k+1} - B_k
 The number of enemies n₁ n₂ n₃...n_k

If the full range of all possible events is covered during the journeys, then the probability of falling to level i

$$p_i = \frac{n_i}{\sum_{i=1}^k n_i} \quad (1)$$

they are. Here, n is the number of reductions to the i-th degree, k is the number of degrees. If the entire range is not covered, then

$$p_i = \frac{n_i \Delta t}{T} \quad (2)$$

they are. Here, Δt is the correspondence of the working period of the time element, T is the period of measurement.

After calculations with formulas (1) and (2), the order of distribution can be described as follows:

Plans B₁ B₂ B₃ ... B_k

Possible $n_1 \ n_2 \ n_3 \ \dots \ n_k$

A histogram is constructed in this order. Each level is named to identify the general characteristics. As a rule, the average value B_i is taken as the name of the level. In this case

$$\bar{V} = \sum_{i=1}^k V_i \cdot p_i, \quad (3)$$

$$N = \sum_{i=1}^k V_i^2 \cdot p_i, \quad (4)$$

$$D = N - (\bar{V})^2, \quad (5)$$

$$\sigma = \sqrt{D} \quad (6)$$

prices are determined.

They can use the following method to facilitate reports. The ranges are numbered so that the zero nearest to the middle of the measured range belongs to the number. To the left of this zero number are negative numbers, and to the right are positive numbers rotated by one unit:

ω_i	-3	-2	-1	0	1	2	3	4
B_i	B_1	B_2	B_3	B_4	B_5	B_6	B_7	B_8

In this case, the intermediate quantities are calculated first:

$$\bar{A} = \sum_{i=1}^k p_i \cdot \omega_i, \quad (7)$$

$$D_A = \sum_{i=1}^k p_i \cdot \omega_i^2 - (\bar{A})^2, \quad (8)$$

Numerical characteristics are determined by intermediate quantities:

$$\bar{V} = V_0 + \Delta V \cdot \bar{A},$$

$$\sigma = \Delta V \cdot \sqrt{D_A},$$

where B_0 is the value of U_i for the case $\omega = 0$.

The accuracy of determining the quality indicator of the quality with the help of the statistical analyzer of the quality depends on the following factors:

1) from the accuracy of determining the values of the probability of falling into the ranks;

2) from the accuracy of determining the numerical characteristics of the distribution series; The first size is determined by the accuracy of the work of organs, and the second, in addition, depends on the number of degrees that divide the size range. The greater the studied range, the more accurate the values of the calculated indicators are, but on the other hand, it causes an increase in the dimensions and price of the device. For experimental purposes, the accuracy of devices with eight levels is considered more appropriate, in this case, the width of each level should not be greater than the value of the standard deviation of the measured deviation.

In this device, the relative placement error of the limits of the levels does not exceed 0.25% of the nominal deviation, the error of the entire range is within $\pm 1\%$. Other things being equal, the reliability of the information obtained by the statistical analyzer of the quality of the disturbance depends to a large extent on the frequency characteristics of the studied process, the shape of the distribution curve and the stability of the time element (timer) operation. In this case, the requirement for the accuracy of the timer's operation applies only to one measurement period, because the error is determined not by the deviation of the device from the set time, but by the time period different from the average value during the measurement period of the device. In order to reduce the impact of the frequency characteristics of the studied process on the cost, it is more appropriate to take the short time periods of the device. On the other hand, it is limited by the number of these meters. Four-level gauges are used in this facility. In order to characterize the histograms obtained with this device, table 1 and table 2 show the same histogram extraction tables with six devices at the same points of the grid. The results obtained in table 1 are given when the time period is 10 seconds, and in table 2, the process of measuring the parameters of excitement is given when the time period is 60 seconds.

Table 1: The results of the measurement of displacement with six devices in a time period of 10 seconds

Device number	The range of probability of falling, %									\bar{B}	σ
	-10 7,5	-7,5 -5,0	-5,0 -2,5	-2,5 0	0 2,5	2,5 5,0	5,0 7,5	7,5 10	0 5		
1	—	0,1	2,4	55,6	30,2	11,6	—	—	41,8	0	1,8
2	—	0,5	2,1	52,7	33,8	11,0	—	—	44,8	0,1	1,8
3	—	0,6	7,8	54,3	29,1	8,3	—	—	37,4	-0,4	1,9
4	—	—	0,8	45,0	38,5	15,6	0,2	—	54,2	0,6	2,0
5	—	0,6	2,9	50,1	32,0	14,4	—	—	46,4	0,2	2,0
6	—	—	1,6	49,6	34,9	13,7	—	—	48,7	0,3	1,9

Probability - histogram	-	0,3	2,95	51,2	33,1	12,4	0,05	-	45,5	0,13	1,9
-------------------------	---	-----	------	------	------	------	------	---	------	------	-----

At the end of each table, the most likely histogram for this process is given. At the end of each table, the most likely histogram for this process is given. From the calculated results, it can be seen that the probability of falling to different levels in different facilities differs to a certain extent.

In this case, these differences are smaller for the 10-second period and larger for the 60-second period. In addition, the shape of the histogram and the character of the parameters of the deviation are the same for all facilities. In the case of a time period of 10 seconds, the value of the mathematical deviation differs from each other by $\pm 0.5\%$, and in the period of 60 seconds, $\pm 0.7\%$.

However, the differences of the standard deviations do not exceed $\pm 0.1\%$. Thus, if you use the information obtained by means of the statistical analyzer of the quality of deviation, it is necessary to draw all the characteristics obtained by means of this facility: the shape of the histogram, the probability of falling into different levels, the average value and the standard deviation. As a lawyer, the most stable information about the road network is standard. Taking this into account, this quantity should be used when determining the quality of the change.

Table 2: The results of the measurement of displacement with six devices in a time period of 60 seconds

Device number	The range of probability of falling, %									\bar{B}	σ
	-10 7,5	-7,5 -5,0	-5,0 -2,5	-2,5 0	0 2,5	2,5 5,0	5,0 7,5	7,5 10	0 5		
1	-	-	0,4	48,1	48,7	2,8	-	-	51,5	0,1	1,4
2	-	-	-	48,3	50,1	1,6	-	-	51,6	0,1	1,3
3	-	-	1,0	53,6	45,4	-	-	-	45,4	-0,1	1,3
4	-	-	0,4	29,6	60,9	9,1	-	-	70,0	0,7	1,5
5	-	-	-	34,6	59,0	6,4	-	-	65,3	0,5	1,4
6	-	-	4,1	66,5	29,1	0,2	-	-	29,4	-0,6	1,3

Probability - histogram	-	-	1,0	46,8	48,5	3,7	-	-	52,2	0,1 2	1,4
-------------------------	---	---	-----	------	------	-----	---	---	------	----------	-----

THE STATISTICAL MEASUREMENT FACILITY OF THE FLOW CHART

As one of the tools used to determine the characteristics of the availability parameters, we can give an example of the statistical size of the availability graph, which measures these characteristics at given time intervals of the day (at given times).

In general, the characteristics can be mathematical curves, standard deviations, and average distributions. These characteristics are given in the structural diagram of the measurement facility in figure 2. The gauge consists of a circuit that converts the measured quantity into a voltage 1, a frequency pulse circuit of that voltage 2, a timing element circuit (timer) 4, an integrating pulse counter 5-12 and a distribution switch 3. Frequency converter 2 generates pulses whose measured quantity is proportional to the first or second order. The quantities of these pulses are counted by means of 5-12 gauges. Thus, during the period when one of the gauges is connected to 2 switches, impulses proportional to the average value of the first or second order of the quantity measured in that gauge are accumulated. As it is known, the average value of the first order of the measured quantity means its mathematical expression, and the average value of the second order of the measured quantity means the inequality of the parameters (the second starting moment). Determining the dispersion characteristics based on the quadratic transformation of the inclinations of the excitation requires this transformation to be carried out with a very high accuracy. This is explained by the fact that the variance consists of the small difference of two large quantities - the second initial moment and the square of the mathematical expression. If we take into account that the variance represents the percentages of singularities in the square, then the accuracy of determining the initial quantities should be characterized with an accuracy of one percent, which is a technically difficult issue. Therefore, when obtaining the characteristics of mathematical analysis and propagation of the solution, the frequency-frequency conversion should be taken as the main element that determines the accuracy of the results.

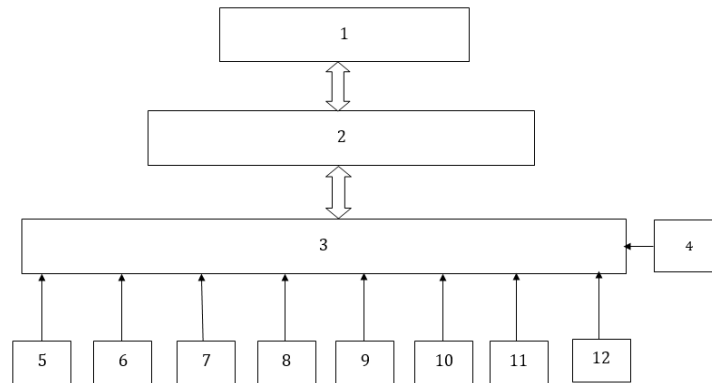

Figure 2. The structural scheme of the statistical measurement device of the flow chart

This facility allows you to calculate the average value (or other quantity) of the parameters of the movement over an hour or more. Guru and day can be divided into eight equal time sections (each with three hours), or they can be taken with integrals that require a different length of time.

CREATING A MEASUREMENT SYSTEM IN THE LABVIEW SOFTWARE PACKAGE

Electrical loads connected to the network must operate on the basis of a certain norm and standard, or on predetermined voltage values. In the recent period, in accordance with the rapid development of technological fields, at the same time, an increase in the negative effects of the loads connected to the source against the voltage in the electric network is also observed. Voltage interruptions, sags or surges, especially the presence of harmonics, are important problems. As we said earlier, these cause malfunctions in devices connected to the electrical network. Even a 0.1-second change, decrease or drop in voltage leads to negative effects in the power supply system that can last for hours. The following areas may be affected:

- Enterprises engaged in continuous production;
- Security systems, lighting structures;
- Computer related fields.

Such problems cause production losses and financial losses in these areas in general. Therefore, the voltage level in the network should be measured regularly, and devices and equipment that cause such negative situations should be identified.

In order to solve this problem, a measuring system has been created, thanks to which it is possible to more accurately detect events such as interruptions in energy supply systems, problems in the network voltage, for example, an increase or decrease in the voltage level. Therefore, it is necessary to make measurements and make necessary analyzes in the voltage distribution device used to feed the loads connected to the network. A measuring card was created in order to ensure the passing of a signal with the required form and value from the electrical network. With it, we reduce the voltage waves of the network to the level we need, send them to the computer through the DAQ (data acquisition) device, and analyze them based on the scheme created with the LabVIEW software package.

The voltage signals of the network are adapted to the input of the DAQ device through the measurement card. The measuring circuit consists of circuit elements operating on the basis of continuous signals. From the waveforms reflected by the oscilloscope, it is clear that only the amplitude levels of the voltage signals are reduced by the measuring card. Then those waves reduced to the required voltage limit are transmitted from the output of the measuring card to the inputs of the data acquisition device (DAQ) that receive continuous signals. The USB-6259 DAQ device was used here. With 16 or 32-bit analog input, 4-bit analog output, and 48-bit discrete I/O, this device sends data to the computer at 6400 baud. The measurement process, continuous acquisition of voltage data from the DAQ card, and data analysis are performed using LabVIEW software, a virtual laboratory. The measurement operation established in the LabVIEW program is described below (Fig. 3). In systems consisting of two or three phases, the variation of voltage waves depending on time can be monitored by means of the scheme given in Fig. Disturbances in voltage signals (increase and decrease in voltage, interruptions, etc.) in the measuring systems we provide are easily determined and recorded in the memory by the computer system. Using this method, a virtual measuring device is created. We can get the optimal solution method by analyzing those data when solving the problems of quality violation in the energy system. In addition, we can note that we can measure and determine the vibrations generated in the voltage waves without using other devices by making some changes through the software.

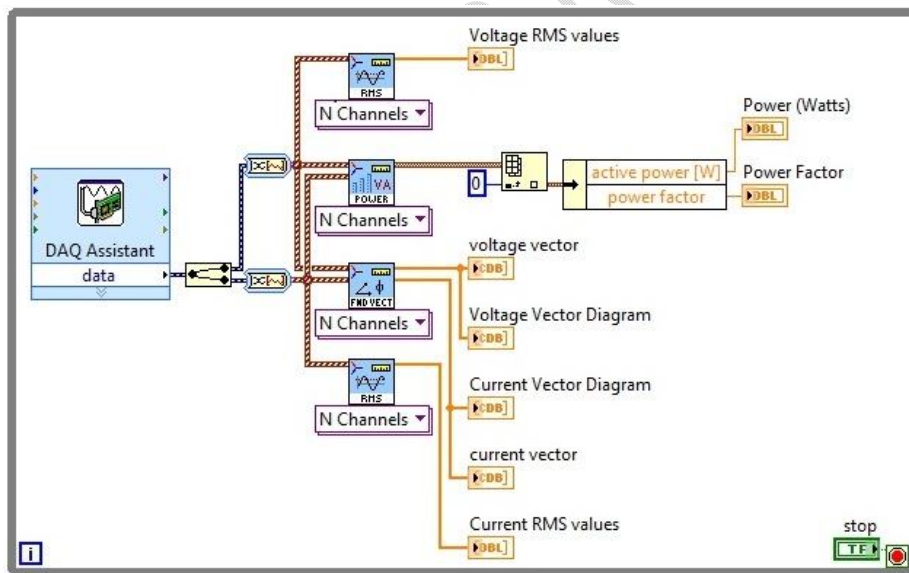

Figure 3. Power quality control scheme through software, taking power factor into account

During the studies, extensive measurements and studies were carried out to determine the electricity losses and consumption, and to perform the cost control process, and the results presented below were obtained:

Quality indicators specific to electric energy have been studied, factors causing non-sinusoidality have been investigated, factors leading to quality violations in the power supply system have been determined.

The parameters and factors characterizing energy quality, their measurement tools and methods were determined, and a virtual measuring device was developed using the LabVIEW software package.

In the LabVIEW program, schemes were developed that visually describe the change of voltage waves in two or three-phase systems in accordance with time, measuring power and power factor.

CONCLUSION

The article presents deterministic and statistical methods for determining voltage deviations. The necessity of improving the quality of electric energy, including the economical use of fuel and energy resources, the economical use of financial resources, and increasing efficiency is substantiated. Voltage deviations, one of the parameters of electric power regulated by standards, are investigated.

Also, a virtual instrument is studied. When measuring with a virtual method, corrective filtration of electrical energy was introduced in each measurement link. This method reduces energy losses, which means that the deviation during transformation does not increase.

Disclaimer (Artificial intelligence)

Option 1:

Author(s) hereby declare that NO generative AI technologies such as Large Language Models (ChatGPT, COPILOT, etc) and text-to-image generators have been used during writing or editing of manuscripts.

Option 2:

Author(s) hereby declare that generative AI technologies such as Large Language Models, etc have been used during writing or editing of manuscripts. This explanation will include the name, version, model, and source of the generative AI technology and as well as all input prompts provided to the generative AI technology

Details of the AI usage are given below:

1. I hereby declare that NO generative AI technologies such as large language models (ChatGPT, COPILOT, etc.) and text-to-image generators were used during the writing or editing of the manuscripts.

2.

3.

REFERENCES

1. Zhezhelenko I.V., Rabinovich L.M., Bozhko V.M. Quality of electricity in industrial enterprises. Kiev, Техника, 2001, 160 с.
2. Yusifov S.I., Mayilov R.A., Mehdiyeva A.M., Mehdizade E.K. Advanced Information-Measuring System for the Improvement of the Quality Indicators of Metrological Characteristics. E3S Web of Conferences (Environment, Energy and Earth Sciences), Vol. 474, 02003 (2024). ISSN: 2267- 1242.
3. Sukhov, E.A., Gurfinkel', L.M., & Popov, Yu.G. (1985). Abstracts of Papers, Conference and Meeting on Hydraulic Engineering. Leningrad: Energoatomizdat.
4. Agayev F.H., Mehdiyeva A.M., Ibrahimova A.E. Advance Technologies to Eliminate Environmental Problems of Oil and Gas Processing. 2nd International Conference on Emerging Applications of Material Science and Technology (ICEAMST 2024), July 3-4, 2024, Bengaluru, India. Advances in Science, Technology & Innovation.
5. Kalatuzov, V.A. (2002). Hydromechanics. Moscow: Izd. MGTU im. N.E. Bauman.
6. Agayev F.H., Mehdiyeva A.M., Gafarov G.A., Bakhshaliyeva S.V., Shirinzade N.V. Development of the functional safety system in primary oil refining Nafta-Gaz. Oil and Gas Institute - National Research Institute. Poland. ISSN 0867-8871. <https://www.inig.pl/en/nafta-gaz-en/available-articles>
7. Sukhov, E.A., Gurfinkel', L.M., & Popov, Yu.G. (1985). Abstracts of Papers, Conference and Meeting on Hydraulic Engineering. Leningrad: Energoatomizdat.
8. Kalatuzov, V.A. (2002). Hydromechanics. Moscow: Izd. MGTU im. N.E. Bauman.
9. Novitskii P.V., Zagraf I.A. Evaluation of errors in measurement results. L. Energoatomizdat, 1985, 248 p.
10. Saligov S.G. On the correction of the integral error of digital devices. Measuring technique, 1980, No. 6, pp. 45-47.
11. Mehdiyeva A.M., Bakhtiyarov I.N., Bakhshaliyeva S.V. Increasing the Immunity of Information Transmission and Fault Tolerance of the Path. Lecture Notes on Data Engineering and Communications Technologies. Volume 166. Proceedings of ICMCSI 2023, 11-12 January 2023. Tribhuvan University, Nepal. pp. 775 – 784.
12. Martyashin A.I., Shakhov E.K., Shlyandin V.M. Converters of electrical parameters for control and measurement systems. M., Energy, 2006. 392 p.
13. Дубовик Е.Н., Коров Н.А. SCADA-system company Siemens, <http://www.siemens.ru>
14. Kofler, M. Visual Basic 6. Programmiertechniken, Datenbanken, Internet. Bonn: Addison-Wesley-Longman Verlag, 2008.
15. OPC Data Access Automation Interface Specification, Version 2.02. Instead of version 2.01; released 02.03.99. OPC Foundation, 1999.

16. Naughton P., Schildt G. Java 2 / Пер. с англ. СПб.: БХВ Санкт-Петербург, 2000. 245 p.
17. Toshpulatov N, Tursunov O, Kodirov D, Maksumkhanova A, Yusupov Z. Study on issues of uninterrupted power supply, energy-saving and improving the quality of electrical energy of water facilities. In IOP Conference Series: Earth and Environmental Science 2020 Dec 1 (Vol. 614, No. 1, p. 012025). IOP Publishing.
18. Muscas C, Pau M, Pegoraro PA, Sulis S. Smart electric energy measurements in power distribution grids. IEEE Instrumentation & Measurement Magazine. 2015 Jan 26;18(1):17-21.
19. Dejanović A, Babić M, Tomašević M. Measuring Electric Power Quality of Renewable Energy Sources. International journal of electrical and computer engineering systems. 2011 Oct 27;2(2):81-8.
20. De La Rosa JJ, Muñoz AM, De Castro AG, López VP, Castillejo JA. A web-based distributed measurement system for electrical power quality assessment. Measurement. 2010 Jul 1;43(6):771-80.

UNDER PEER REVIEW