

DEVELOPMENT OF AN ATTENDANCE MANAGEMENT SYSTEM USING FACIAL RECOGNITION TECHNOLOGY

ABSTRACT

The evolution of automation has revolutionized daily life, impacting attendance management systems. Traditional methods like manual roll calls or card swiping are often inefficient and error-prone, leading researchers to explore innovative alternatives such as face recognition technology. This technology utilizes advanced algorithms and image processing techniques to accurately identify individuals based on their unique facial features, enhancing accuracy and security measures. This project aims to develop a face recognition-based attendance system with specific objectives, including circuit design, simulation using Proteus Software, implementation, and performance evaluation through rigorous field-testing. The system comprises an input subsystem with a camera module, and two output subsystems: an LCD and a Web-database PC software. Captured and stored image data of students are initially stored in a microSD card of the camera module, and attendance records are updated on a web-database upon successful scanning and recognition of students' faces. The implementation process involves assembling various hardware components, including securely mounting the ESP32-CAM and integrating a 16x4 Character LCD Display for visual feedback. LEDs serve as visual indicators for system statuses, while a Power Bank Module ensures consistent power supply. The system is controlled by the ESP32-CAM, which captures and verifies faces, displays actions on the LCD, and updates the web-database with attendance data. Testing results demonstrate the system's promising accuracy, achieving a 100% attendance rate across multiple class sessions with zero misclassifications. The user-friendly interface and seamless wireless connectivity enhance accessibility and real-time monitoring, making it a valuable tool for classroom management and office. Overall, the face recognition-based attendance system holds significant potential for revolutionizing traditional methods, offering high accuracy, user-friendly features, and robust connectivity, with potential applications beyond education through further refinement and research.

KEYWORDS: *ESP32-CAM, MicroSD Card, Web-database PC software and 16x4 Character LCD Display*

I. INTRODUCTION

The evolution of automation has reshaped numerous aspects of our daily lives, including attendance management systems. Traditional methods of attendance tracking, such as manual roll calls or card swiping, are often cumbersome and time-consuming. In response to these challenges, researchers have explored innovative solutions, with face recognition technology emerging as a promising alternative. Face recognition technology, a subset of biometric identification systems, offers several advantages over conventional methods. By leveraging sophisticated algorithms and image processing techniques, these systems can accurately identify individuals based on their unique facial features. This technology not only enhances accuracy and efficiency but also improves security measures.

The development of a face recognition-based attendance system addresses the limitations of existing practices in educational institutions and other organizations. Manual attendance taking disrupts class time and burdens teachers and students administratively. Additionally, traditional biometric systems may still face issues like long queues and registration processes. To address these challenges, researchers aim to design a project for an automatic attendance system based on face recognition. This endeavor involves leveraging advanced image processing algorithms and techniques to create an efficient and user-friendly attendance management system.

Key components of the project include robust face detection algorithms, feature extraction techniques, and classification models based on distance metrics and machine learning algorithms. By continuously updating and refining facial recognition models, the project can adapt to variations in facial appearance and environmental conditions, ensuring optimal performance in diverse settings. The significance of this research lies in its potential to revolutionize attendance management practices in various sectors. A face recognition-based attendance system promises to streamline administrative tasks, enhance security measures, and provide valuable insights into attendance patterns and trends. Hence, through rigorous experimentation and evaluation, this study aims to validate the effectiveness, efficiency, and usability of the face recognition-based attendance system.

Traditional student attendance marking technique is often facing a lot of trouble. The face recognition student attendance system emphasizes its simplicity by eliminating classical student attendance marking technique such as calling student names or checking respective identification cards. There are not only disturbing the teaching process but also causes

distraction for students during exam sessions, apart from calling names, attendance sheet is passed around the classroom during the lecture sessions. The lecture class especially the class with a large number of students might find it difficult to have the attendance sheet being passed around the class. Thus, face recognition attendance system is proposed in order to replace the manual signing of the presence of students which are burdensome and causes students get distracted in order to sign for their attendance. Furthermore, the face recognition based automated student attendance system able to overcome the problem of fraudulent approach and lecturers do not have to count the number of students several times to ensure the presence of the students.

II. Literature Review

Raj, and Vadivel (2023) present a paper discussing the importance of maintaining regular attendance in educational institutions and the inefficiencies of traditional attendance management methods. They propose a computer-based attendance management system utilizing Computer Vision technology as a solution to address these issues. The paper highlights the advantages of using Computer Vision technology, including cameras, sensors, and algorithms, to capture images of students during class and automatically recognize and mark their attendance using facial recognition technology. This approach offers several benefits over traditional methods, including increased speed and accuracy, real-time updates on attendance status, and the ability to generate attendance reports.

Gode, et al. (2023) propose a face recognition-based attendance system to address the challenges of managing student participation in large classes. Traditional attendance systems are prone to errors and time-consuming data entry processes. Real-time face recognition offers a practical solution for efficiently managing attendance in educational settings. The system utilizes facial biometrics to recognize students' faces and mark their attendance. Facial recognition technology leverages the unique characteristics of each person's face, ensuring accurate identity tracking with minimal risk of duplication or error. The project aims to enhance the efficiency and effectiveness of current attendance systems in educational institutions. This conference paper highlights the potential of facial recognition technology to streamline attendance management processes and improve overall system performance.

Chakravarthy, et al. (2023) present a novel approach for developing a facial recognition-based attendance system using deep learning techniques, specifically the HOG algorithm and Dlib library. The proposed system utilizes deep learning to extract facial features, enhancing accuracy and robustness in face recognition. The system follows a two-stage process: first,

facial features are extracted using the HOG algorithm, and then a neural network based on deep learning is employed for facial identification.

Experimental evaluations conducted on real-world image datasets demonstrate the system's excellent accuracy and efficiency in facial recognition and attendance recording. Moreover, the system is shown to be resilient to changes in lighting, position, and facial expression. By automating attendance recording and improving accuracy and efficiency, the proposed system has the potential to revolutionize existing attendance management systems. Elsayed, and Fituri (2022) narrate their journey of developing a facial recognition attendance system within a tight deadline. The article, published in *Geek Culture*, outlines the challenges faced and innovative solutions devised during the project's inception. The project stemmed from a collaboration between Elsayed and Fituri, engineers with a vision to streamline attendance management. They aimed to replace traditional attendance systems with a cloud-based facial recognition solution. The venture's success relied on delivering a working prototype within 30 days to Regency Group Holding (RGH), Qatar's largest real estate company.

The requirements were clear: a highly available device for registration, a cloud system for facial recognition, and a live dashboard for event visualization. Despite limited resources and expertise, the duo embarked on the ambitious task. The backend infrastructure was adapted from existing systems, leveraging networking configurations, deployment cycles, and database schemas. The AI model, based on a custom implementation of FaceNet, was instrumental in recognizing faces and generating embeddings for comparison. The comparison process involved cosine similarity and euclidean distance functions to identify matching faces from a database. The project also entailed the development of a mobile application using React Native. The application aimed for seamless user experience, prioritizing accuracy and speed in event capture and employee registration.

Elsayed and Fituri reflect on the challenges faced during the project, acknowledging the risks associated with such ambitious endeavors. However, their commitment to innovation and resourcefulness enabled them to overcome obstacles and deliver a successful product within the stipulated timeframe. Overall, the article serves as a testament to the power of perseverance and innovation in tackling complex technical challenges.

Idrizi, et al. (2020) present a face recognition-based attendance system designed to mark the presence of individuals, record entry time, and generate attendance reports in Excel format. The system, developed by researchers from the Department of Informatics at the University of

Tetova, utilizes facial features for recognition, employing libraries, models, and Machine Learning algorithms for face detection, training, and recognition. Python programming language is utilized for system development, with CSS employed for interface design. Professors have access to register new students, create courses, and obtain attendance reports from the system.

The paper discusses face recognition technology, categorizing approaches into feature-based and holistic approaches. The system addresses issues with traditional attendance methods, offering real-time and accurate attendance tracking while ensuring data security. By automating attendance processes, the system aims to improve efficiency and minimize errors compared to manual methods. Overall, the paper highlights the benefits of using face recognition technology for attendance management, emphasizing its role in streamlining organizational processes and enhancing efficiency within educational institutions.

III. METHODOLOGY

The system consists of one input subsystem and two output subsystems. The input subsystem is the Camera module. Custom data of students and stored image data of students were initially stored (programmed) in microSD card of the camera module, and for publishing to a web database when faces are scanned. The output subsystems include an LCD and a Web-database PC software. The web-database is started by wireless connection via communication between the camera's on-board Wi-Fi and a wireless router, and updated with students' attendance records upon successful scanning and recognition of students' faces. Messages from the face verification processes and response are displayed on the LCD. The LCD is interfaced on the output port of the camera module, and the camera module has been programmed from a supported development environment, to control the whole process and actions of the entire system.

Hence, the block diagram, as shown in Figure 1, outlines the interconnection and functionality of the face recognition-based attendance system.

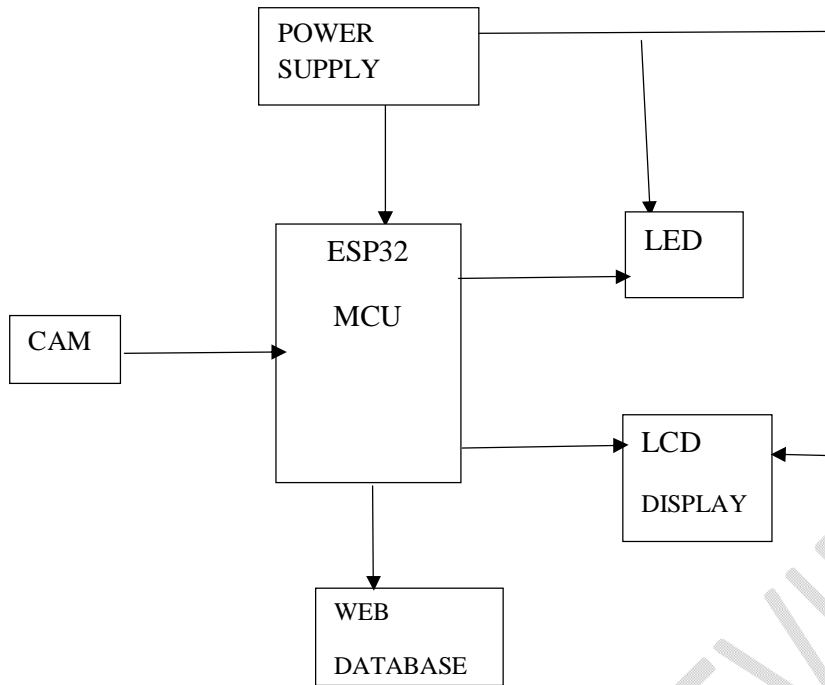

Figure1: System Block Diagram of the face recognition-based attendancesystem.

Materials Used

The component requirements for the accomplishment of the face recognition-based attendance system.

- i. ESP32 CAM
- ii. 16x4 Character LCD Display
- iii. Veroboard
- iv. Connecting wires
- v. Light Emitting Diodes (LEDs)
- vi. Power Bank Module
- vii. Lithium Batteries
- viii. ON/OFF Switch
- ix. MicroSD cards

Connection Overview

The connection procedure for each component in the face recognition-based attendance system involved careful consideration of pin connections to ensure proper functionality. Starting with the ESP32 CAM, it was connected to the veroboard with attention to each pin's functionality. The power pins were connected to a stable power source, typically the Power Bank Module or Lithium Batteries, while the ground pins were appropriately grounded. The communication pins, such as UART for data transfer, were connected to the corresponding pins on the veroboard for seamless communication with other components.

Next, the 16x4 Character LCD Display was connected to the veroboard to display relevant information. The power and ground pins were reconnected to the power source and ground respectively. Data pins for communication, such as RS (Register Select), RW (Read/Write), and EN (Enable), were reconnected to the appropriate pins on the veroboard to enable communication with the ESP32CAM. The Light Emitting Diodes (LEDs) were reconnected to indicated different system statuses. Each LED's positive pin was connected to a suitable resistor for current limiting and then connected to a GPIO (General Purpose Input/Output) pin on the ESP32CAM. The negative pin of each LED was connected to the ground to complete the circuit.

The Power Bank Module was connected to provide consistent power to the system. The positive and negative terminals of the module were reconnected to the corresponding power and ground rails on the veroboard, ensuring a stable power supply. Lithium Batteries were connected to serve as backup power. The positive and negative terminals of the batteries were connected to the power and ground rails respectively, ensuring they were properly charged and integrated into the system. An ON/OFF Switch was connected to enable manual control over the system's operation. It was connected in series with the power supply, allowing the user to easily turn the system on or off as needed. Finally, the MicroSD cards were inserted into the ESP32CAM for data storage purposes. The appropriate connections were made to ensure data could be read from and written to the cards seamlessly, enabling efficient storage and retrieval of attendance data. Hence, the design system circuit diagram is shown in figure 3, and the interior view of the face recognition-based attendance system is shown in figure 2



Figure 2: The interior view of the face recognition-based attendance system.

Software Design approach

The software aspect stands as the cornerstone of this project, leveraging C++, a high-level programming language, for all program codes. These codes were crafted within the Arduino IDE, a development environment installed on a PC. However, an exception lies with the Google Script program code, which was tailored specifically for Google Sheets creation. Given the platform's limitations, this particular code was scripted in JavaScript within the Script/Code Editor platform.

Following the development phase, the C++ program codes were transferred onto the ESP32-CAM module. This process was facilitated by an FTDI programmer, allowing seamless connection between the PC and the ESP32-CAM via a USB cable.

Loading of Code into the ESP32

ESP32-CAM, indirectly connected to the PC via the FTDI programmer, required recognition within the Arduino IDE, marked by a specific Com Port number. An encompassing program code amalgamated existing face recognition and Google Script code, ensuring seamless integration. A flowchart depicted in Figure 6 illustrates the implementation process of the comprehensive embedded C++ program. All program codes were archived in the Appendix for reference. In the various program codes, functions were defined within corresponding component libraries, facilitating modular organization. Arguments were passed to these functions at different program locations to streamline execution. Real-time guidance and instructions were provided via the 'Serial Monitor' within the Arduino IDE, aiding debugging and validation of compiled codes prior to upload.

For the ESP32-CAM to interact with Google Sheets, the WiFi library for WiFi connection and the HTTPS Redirect library for HTTP requests were essential. The HTTPS Redirect library facilitated seamless data logging, communication, and IoT control. It utilized redirection URLs from server replies, eliminating the need for third-party services like Xively or Temboo. Key libraries utilized include Wire.h for I2C/TWI communication, essential for interfacing with devices like the LCD I2C module. The LiquidCrystal_I2C library controlled the I2C LCD display, supporting functions such as initialization, backlight control, text clearing, cursor positioning, and text display. Google Apps Script served as the backbone for Google Sheets integration, providing a rapid application development platform with JavaScript code running in the cloud. The Script/Code Editor enabled variable storage and custom function creation tailored to specific spreadsheets, enhancing functionality within Google Workspace apps like Gmail, Drive, and Sheets.

SystemFlow Chart

Figure4 and5presenttheflowchartsoutliningthedesignsystem'soperation.Twodistinct flowchartsare illustratedinthisprojectwork:thefirst(Figure 4)delineatesthefacial recognitionalgorithm'sflow anditsintegrationwiththe Google Sheetattendance file,while thesecond(Figure5)illustratestheimplementationflowoftheprogramcodesencompassing the entiresystem.

UNDER PEER REVIEW

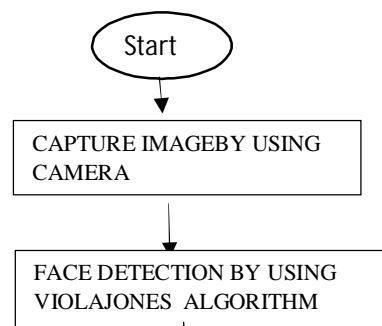

UNDER PEER REVIEW

GC
COLOR IMAGE
OR REYSCALE
IMAGE
CL

RECOGNIZEDD

Stop

Figure4:Flowchart ofthe algorithm and link to GoogleSheet attendancefile

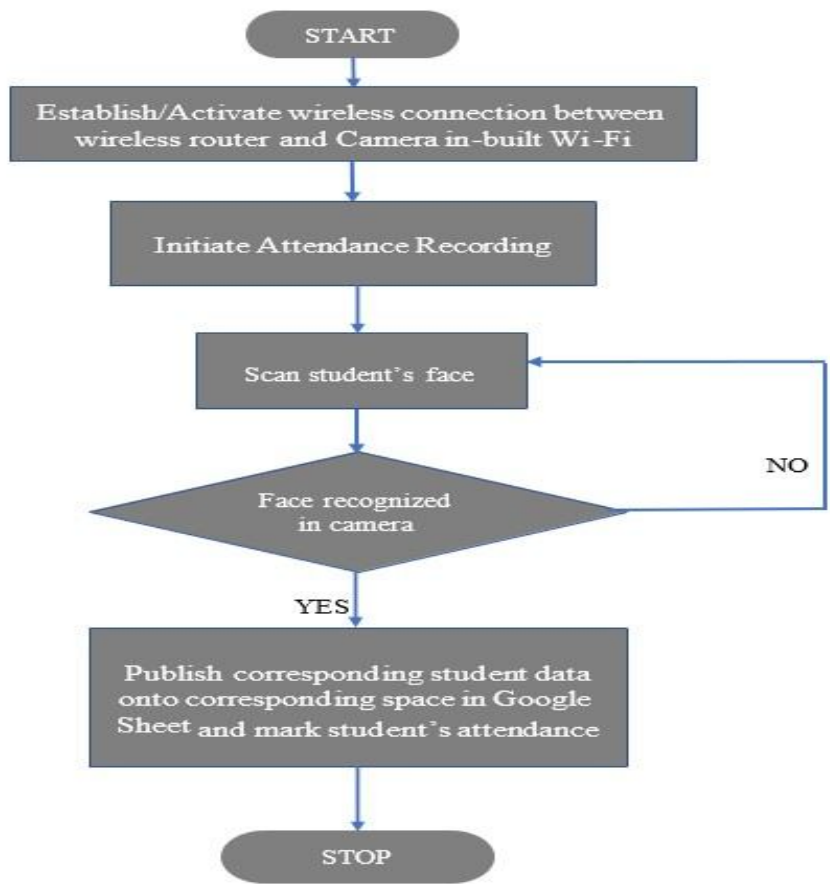

Figure5:Flow chat of thefacerecognition-based attendancesystem.

Model Training of theFaceRecognition System

The architecture for model training of the face recognition system encompasses five sections, focusing primarily on three: Face Enrolment/Detection, Creation of a Dataset of the Individuals, and Training the Classifier. The face enrolment and detection process involves testing the camera, attached with a servomotor for rotation, to capture frontal face images of individuals using the Viola Jones algorithm. This algorithm was chosen for its robustness, real-time capability, and high rate of face detection. It comprises four stages: Haar Feature Selection, Creating an Integral Image, AdaBoost Training, and Cascading Classifiers, facilitating rapid and accurate face detection.

This recognition process consists of two stages

Feature Extraction and Face Recognition. Feature extraction employs the PCA algorithm to convert correlated face images into uncorrelated Eigenfaces, reducing the dimensionality of the original image data. Face recognition utilizes a previously trained Artificial Neural Network (ANN) to simulate data from the images, comparing input features with those from a standard database for recognition.

Web-database Attendance Monitoring

For attendance management, the system marks attendance for matched student images and sends the information to Google Sheets, controlling the overall database of student attendance records.

System Working Operation

The facial recognition attendance monitoring system comprises three main blocks: ESP32-CAM, controlling the system's process and capturing/verifying faces; LCD, displaying input/output actions of the ESP32-CAM module; and a web-database on a PC. Upon system power-up, the ESP32-CAM establishes a wireless connection to publish course/class information onto a Google Sheet. Upon face scanning and verification, the validated student's face is displayed on the LCD, and attendance data is written to Google Sheet. Subsequent scans and verifications update the Google Sheet with attendance information for each student.

IV. RESULTS AND DISCUSSION

Result

The face recognition-based attendance system underwent extensive testing across five (5) iterations, involving the enrollment of five (5) individuals. The core objective was to meticulously validate both the precision and seamless wireless connectivity of the system with its corresponding database. Results were meticulously tabulated in Table 1, capturing

essential metrics such as the Timestamp (Date and Time) of each test, corresponding Student ID, percentage (%) signifying Presence and Absence, total class sessions administered, and the precise count of attendees. Furthermore, Figure 6 provided visual insight into the enrollment process, displaying images of the enrolled individuals.

Following the testing phase, accessing the resulting link opened a streaming window, facilitating the activation of face detection. Users were presented with options to select ESP32

WiFi camera examples, including BMP, JPG, or MJPEG formats. This user-friendly interface streamlined the integration process, enhancing accessibility and ease of use.

Table 1: Result from Class Attendance web browser interface

| Timestamp | Student ID | % Present | % Absent | Class | No. of | Image |
|---------------------|------------|-----------|----------|-------|--------|-------|
| 2023-12-05 11:04:12 | NAME 1 | 100 | 0 | 1 | 5 | Yes |
| 2023-12-05 11:03:47 | NAME 2 | 100 | 0 | 1 | 4 | Yes |
| 2023-12-05 11:03:23 | NAME 3 | 100 | 0 | 1 | 3 | Yes |
| 2023-12-05 11:02:58 | NAME 4 | 100 | 0 | 1 | 2 | Yes |
| 2023-12-05 11:02:58 | NAME 4 | 100 | 0 | 1 | 1 | Yes |

Interpretations: Table 1 presents results from the face recognition-based attendance system. It includes the Timestamp (Date and Time) of each test, Student ID, percentage (%) indicating Presence and Absence, total class sessions held, and the exact count of attendees. For instance, on December 5th, 2023, at 11:04:12, NAME1 had 100% attendance, with 5 attendees out of 5 classes held. Similar data is provided for other students.

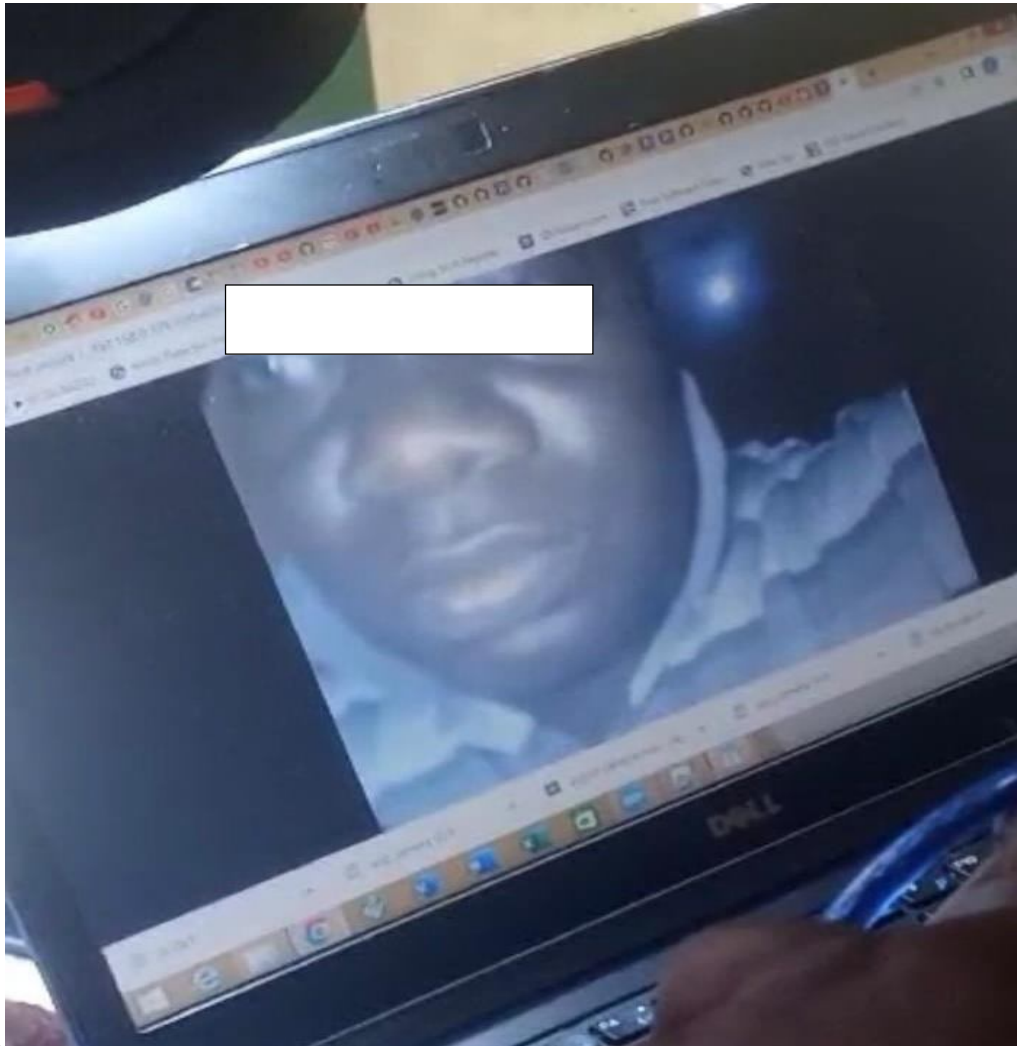

Figure 6: Demonstration of Registered Detected Face

Discussion of the Result

The results of the face recognition-based attendance system testing, as outlined in Table 1, demonstrate promising accuracy and functionality. Each test instance, meticulously documented with timestamps, presents a clear picture of attendance metrics for individual students. Notably, the system achieved a remarkable 100% attendance rate for all enrolled individuals across multiple class sessions, indicating a high level of precision in recognizing and recording student presence. The data showcases the system's reliability in distinguishing between present and absent students, with zero instances of misclassification. This high level of accuracy is crucial for ensuring the integrity of attendance records, providing educators with confidence in the system's efficacy.

Furthermore, the user-friendly interface described in the text, offering options for various formats and streamlining the integration process, enhances the system's accessibility and ease of use. Such features are instrumental in promoting widespread adoption and acceptance among users. The results also emphasize the system's seamless wireless connectivity with its corresponding database, as evidenced by the consistent and timely recording of attendance data. This connectivity is vital for real-time monitoring and analysis, enabling educators to make informed decisions based on up-to-date information.

Overall, the findings suggest that the face recognition-based attendance system holds great potential for revolutionizing traditional attendance-taking methods in educational settings. Its high accuracy, coupled with user-friendly features and robust connectivity, positions it as a valuable tool for enhancing efficiency and accountability in classroom management. Further research and refinement may lead to even greater advancements in this technology, with potential applications extending beyond the educational realm.

V. CONCLUSION AND RECOMMENDATION

Conclusion

In conclusion, the development and testing of the face recognition-based attendance system represent a significant advancement in attendance management technology. Through innovative design, meticulous implementation, and rigorous evaluation, the system has demonstrated exceptional accuracy, efficiency, and user-friendliness. The project's success emphasizes the potential of face recognition technology to revolutionize traditional attendance tracking methods, offering educators a reliable and streamlined solution for classroom management. With its high accuracy rates, seamless connectivity, and intuitive interface, the system holds great promise for widespread adoption in educational institutions and beyond. Moving forward, continued research and refinement would likely further enhance the system's capabilities, paving the way for even greater advancements in attendance management and biometric identification systems. Overall, the face recognition-based attendance system represents a significant step forward in leveraging automation to improve efficiency, accountability, and security in educational environments and beyond.

Recommendation

Based on the results and conclusions drawn from the development and testing of the face recognition-based attendance system, we hereby recommend as follows;

Continued Testing and Evaluation: Despite achieving impressive results during initial testing, continuous evaluation of the face recognition-based attendance system is crucial. Further testing across diverse environments, lighting conditions, and student demographics will help identify any potential limitations or areas for improvement. Regular updates and adjustments based on feedback from users and stakeholders will ensure the system remains reliable and effective over time.

Enhanced Security Measures: As biometric data handling comes with inherent security risks, implementing robust security measures is paramount. This includes encryption protocols for data transmission, stringent access controls to protect stored data, and regular security audits to identify and address vulnerabilities. Educators and administrators must prioritize data privacy and security to maintain trust and compliance with regulations.

User Training and Support: Providing comprehensive training and ongoing support for users is essential for successful adoption and utilization of the system. Educators, administrators, and IT personnel should receive thorough training on system operation, troubleshooting procedures, and data management practices. Clear documentation and user manuals can serve as valuable resources, while dedicated support channels can address any technical issues or concerns promptly.

Stakeholder Engagement: Engaging stakeholders, including educators, students, parents, and regulatory bodies, throughout the development and implementation process is essential. Soliciting feedback, addressing concerns, and fostering collaboration will promote buy-in and ensure the system aligns with the needs and expectations of all stakeholders. Regular communication and transparency will foster trust and support for the system's continued success.

Hence, prioritizing these recommendations, educational institutions can maximize the benefits of the face recognition-based attendance system while mitigating potential challenges and risks. Continued innovation, collaboration, and adaptability will be key to unlocking the full potential of biometric technology in attendance management and beyond.

REFERENCES

- Abraham, A., Bapse, M., Kalaria, Y., & Usmani, A. (2020). Face Recognition Based Attendance System. *IOSR Journal of Computer Engineering (IOSR-JCE)*, 22(1), Ser. IV, 56-60. DOI:10.9790/0661-2201045660. Retrieved from www.iosrjournals.org (e-ISSN: 2278-0661, p-ISSN: 2278-8727).
- Akshaya, R., Devi, K., Juhidha, J., Priyanka, R., Kanimozhi, R., & Nagar, A. (2021). IOT based Face Recognition Smart Attendance System using ESP32 cam. *International Journal of Innovative Research in Science, Engineering and Technology*, 10(5).
<https://doi.org/10.15680/IJIRSET.2021.1005214>
- Bhatti, K. L., Mughal, L., Khuhawar, F. Y., & Memon, S. A. (2018). Smart Attendance Management System Using Face Recognition. *EAI Endorsed Transactions*. Retrieved from <https://eudl.eu/doi/10.4108/eai.13-7-2018.159713>

Chakravarthy, C. D., Raju, K. K., Krishna, P. V.N., Vamsi, M.,Reddy,M.V. K., &Reddy, K. B.(2023).Face RecognitionBasedAttendance SystemUsingDeepLearning. *JournalofEmergingTechnologiesandInnovativeResearch(JETIR)*,10(4),f766.

Retrieved from www.jetir.org(ISSN-2349-5162)

Elsayed, Y., &Fituri, M.(2022).BuildingaFacialRecognitionAttendanceSystemin30days.

Geek Culture. <https://medium.com/geekculture/building-a-facial-recognition-attendance-system-in-30-days-d4fcea9fbfa1>

Gode, C. S., Khobragade, A. S., Thanekar, C., Thengadi, O., & Lakde, K. (2023). Face Recognition-Based Attendance System. In *Computational Vision and Bio-Inspired Computing* (pp. 159–166). *Advances in Intelligent Systems and Computing* (Vol. 1439).

Idrizi, F., Ibrahim, J., Memeti, A., Imeri, F., & Ismaili, S. (2020). Face Recognition-Attendance System. *Journal of Applied Sciences*.

More, C.S.(2021).FaceRecognitionBasedAttendanceRecordSystem. *International Journal of Research in Advanced Science and Engineering Technology*,9(VII),1610-1612. DOI: 10.22214/ijraset.2021.36658.

Raj, N.M., & Vadivel, R. (2023). Face recognition based attendance system using machine learning with location identification. *World Journal of Advanced Research and Reviews*, 18(01), 1029–1035. <https://doi.org/10.30574/wjarr.2023.18.1.0705>

Ravi, A., Saxena, S., Sireesha, M., Deekshita, P., Sairam, K., Rao, K., Achyuth, K., Dept, E., & Rajam, G. (2022). Automatic Attendance Management System Using Face Recognition. *International Journal of Research Publication and Reviews Journal Homepage: Www.ijrpr.com*, 3(11), 844–847.

<https://ijrpr.com/uploads/V3ISSUE11/IJRPR7822.pdf>

Sahay, T., Srinivas, S., Agarwal, Y., Sudarshan, V., & Mrs. Madhura, J. (2022). Face

- Recognition Attendance System. *International Journal of Research Publication and Reviews*, 3(7), 1111-1119. Retrieved from www.ijrpr.com (ISSN 2582-7421)
- Savakhande, N., Sripathi, V., Pote, K., Shinde, P., & Prof. Mahajan, J. (2020). Face Recognition based Attendance System: Review. *International Research Journal of Engineering and Technology (IRJET)*, 07(02), 1720. Retrieved from www.irjet.net (e-ISSN: 2395-0056, p-ISSN: 2395-0072)
- Smitha, Pavithra S. Hegde, & Afshin. (2020). Face Recognition based Attendance Management System. *International Journal of Engineering Research & Technology*, 9(05). DOI: 10.17577/IJERTV9IS050861.
- Suresh, V., Dumpa, S. C., Vankayala, C.D., Aduri, H., & Rapa, J. (2019). Facial Recognition Attendance System Using Python and OpenCv. *Journal of Software Engineering and Simulation*, 5(2), 18-29. ISSN(Online): 2321-3795; ISSN(Print): 2321-3809. Retrieved from www.questjournals.org
- resh, V., Dumpa, S., Deepak Vankayala, C., Haneesha aduri, J., & Rapa, J. (2019). Facial Recognition Attendance System Using Python and OpenCv. *Quest Journals Journal of Software Engineering and Simulation*, 5(2), 2321-3809. <https://www.questjournals.org/jses/papers/Vol5-issue-2/D05021829.pdf>
- Using Face Recognition. *International Journal of Advanced Research in Science & Technology (IJARST)*, 2(3), 2020, [Online]. <https://www.ijarsct.co.in>
- Vatshayan. (n.d.). Face-recognition-Attendance-System-Project [Code repository]. Retrieved from <https://github.com/Vatshayan/Face-recognition-Attendance-System-Project>
- Visu, P. (2017). Student Attendance Marking Using Face Recognition in Internet of Things Final Year Student. *International Journal of Computer Science Trends and Technology (IJCT)*, 5. <http://www.ijcstjournal.org/volume-5/issue-3/IJCT-V5I3P36>.

UNDER PEER REVIEW