

Design of an All-in-One Drowning Prevention and Monitoring System

ABSTRACT

The frequent occurrence of drowning accidents has brought a large negative impact on the whole society. In response to this situation, in order to improve the traditional waterside supervision and protection facilities and reduce drowning accidents, this paper illustrates an all-in-one drowning prevention and monitoring system with a modular design, and carries out a large number of experiments and optimisation of the system's functions such as danger warning and real-time monitoring. The results show that the system can efficiently achieve the functions of alarm and distress in drowning accidents and reduce the occurrence of drowning accidents.

Keywords: drowning; monitoring system; Open Cv; Raspberry Pi.

1. INTRODUCTION

According to the latest report data from the World Health Organization (WHO), at least 236,000 people die from drowning every year worldwide [1]. In China, about 57,000 people die from drowning accidents every year, with an average of 161 people dying from drowning every day [2]. Statistically, rivers, reservoirs, and ponds have become the most dangerous places where drowning is most likely to occur and the drowning rate is high [3]. These places are extensive, especially in wild waters and underdeveloped villages, where supervision and protection measures are not fully implemented and effective warning of dangers is lacking. If only relying on manual patrols or traditional surveillance cameras to monitor the water, it is difficult to detect the risk of drowning in time and reach the person who fell into the water in the first time. In response to the rapid and hidden nature of drowning accidents, and in order to ensure that those who fall into the water are rescued in a timely manner, an intelligent drowning prevention and monitoring system has been designed to make up for the shortcomings of traditional ways of regulating waters.

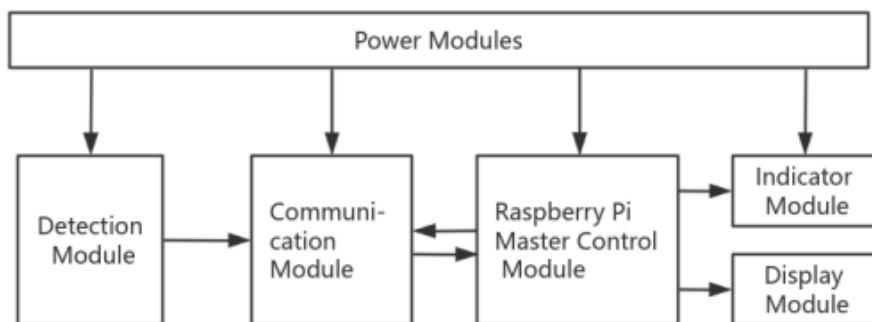

Fig. 1. System schematic diagram

2. THE OVERALL SYSTEM DESIGN PROGRAMME

The schematic diagram of the system is shown in Figure 1. The all-in-one anti-drowning monitoring system can be divided into five modules: detection module, communication module, main control unit, indicator module and display module, which mainly include Open Cv, Raspberry Pi, ESP8266, rescue boat and mobile APP. The all-in-one anti-drowning monitoring system uses Raspberry Pi as the central processor of the system. Connecting the communication module with the camera, when the detection module detects that someone is about to enter the water, a warning is issued, and when a drowning situation is detected, the signal is transmitted to the Raspberry Pi through the communication module. The main control module can analyse the data obtained and deduce the path[4], send instructions to the rescue device and buzzer of the indicator module to activate the rescue device and issue an alarm to ensure that the person who has fallen into the water is rescued in time. At the same time, the mobile APP of the display module receives the data processed by the Raspberry Pi through the communication module and presents it to the rescuer. The rescuer can understand the situation of the person in the water according to the information, which greatly improves the rescue efficiency.

3.SYSTEM HARDWARE DESIGN

The hardware design part of the system includes power management system design, image acquisition design, communication module design, warning system design and power source design. The power management system is connected to each module to increase the appropriate working voltage and current for each module, as shown in Figure 2 and Figure 3.

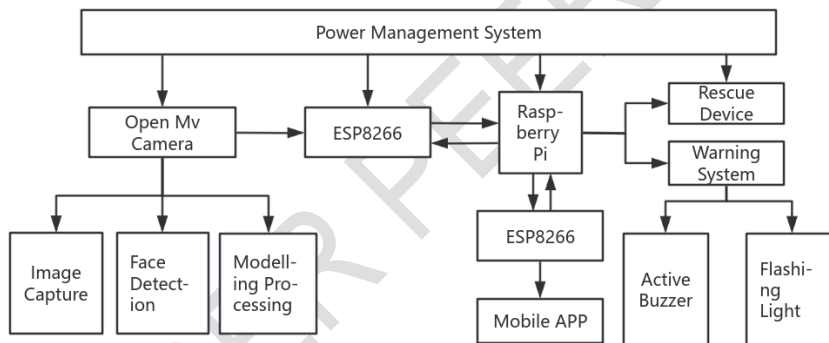

Fig. 2 .Schematic diagram of system hardware design

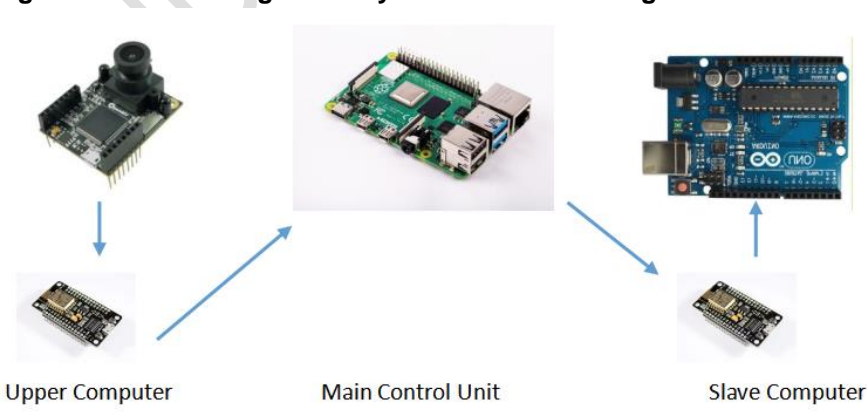

Fig.3.Key hardware display

3.1 POWER MANAGEMENT SYSTEM DESIGN

Aiming at the problem of large power consumption of the ESP8266[5] module, this system uses a 12V solar cell combined with a rechargeable lithium battery to power the device [6], generates a 5V stable DC voltage through a buck converter to supply power to the Open Mv camera and Raspberry Pi, and generates a 3.3V stable DC voltage through a buck converter to supply power to the ESP8266 module.

3.2 IMAGE ACQUISITION DESIGN

The all-in-one drowning prevention and detection system requires high accuracy and reliability of the camera. This system adopts Open Mv camera[7] for image acquisition, which has powerful image processing and analysis capabilities, and can adapt to different environments and lighting conditions, which helps to accurately identify the situation of people entering the water, and improve the accuracy and reliability of the system.

3.3 COMMUNICATION MODULE DESIGN

ESP8266 supports Wi-Fi messengerless communication, this system selects the Wi-Fi module of ESP8266 as the transmission communication device, model ESP-01, so that the upper computer and the lower computer are connected and communicated with each other, and there is no need for wiring, which reduces the complexity of the system and the installation cost.

3.4 WARNING SYSTEM DESIGN

The warning system consists of an active buzzer[8] and a burst light. When a person is detected at the edge of the water, the buzzer works to activate the alarm tone, reminding the relevant personnel to pay attention to safety and stay away from dangerous waters; when a falling water event is detected, the buzzer and the burst flash light work at the same time to attract the attention of passers-by and ensure that the person who has fallen into the water is rescued in the first time.

3.5 POWER SOURCE DESIGN

Power module for the rescue device to provide power output, this system selects the motor is LBP5692/4D, the use of relay circuit control brushless DC motor[9], to ensure that the rescue device in the receipt of instructions can immediately respond.

4 SYSTEM SOFTWARE DESIGN

The software design of the system primarily encompasses detection module design , main control module design and the service platform design. For the detection module and the main control module using PyCharm tools for Python language programming, for the mobile APP using the APP Inventor 2 web platform for development.

4.1 DETECTION MODULE

The flow chart of the detection module programme is shown in Figure 4. The PyCharm tool is used to write the main program, which calls the Open Cv library for image preprocessing and image feature extraction [10]. Open Cv has image processing functions that cover most of the application areas of computer vision, including feature detection, feature matching, image filtering, image segmentation, and other rich image processing and computer vision functions. The system is powered up for initialisation and fault diagnosis, and appropriate processing measures are taken according to the type and severity of the fault. After the system is normal, the Open Mv camera acquires the video image, and after model processing [11] outputs the result as a picture or video, the result contains real-time identification markers of people who are at the edge of the water and may be drowning, and determines whether to send out signals and alarms based on the results of the identification.

The detection effect of this system is shown in Figure 5.

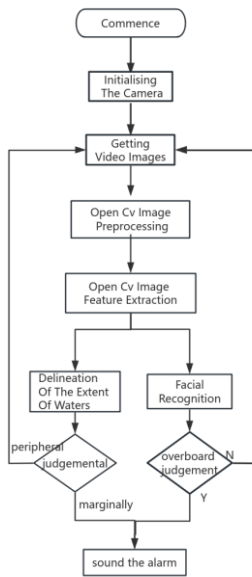

Fig. 4. Detection module programme flow chart

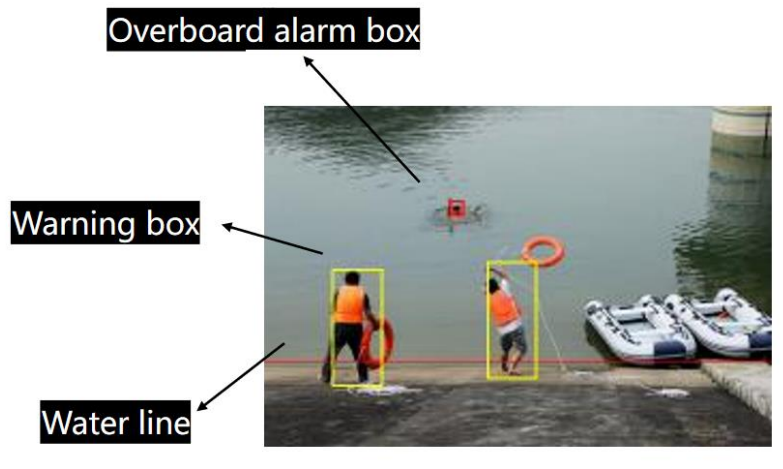

Fig. 5. Detection effect chart

4.2 MASTER CONTROL MODULE

The main control module programme flowchart is shown in Figure 6. The system initialises on power-up, initialises the modules, and then carries out fault diagnosis. If a fault occurs, take appropriate processing measures according to the type and severity of the fault. The system selects Raspberry Pi as the central processor to carry out the data processing of the whole system and work with other modules. After receiving the data transmitted by the detection module, it is able to quickly handle and make accurate judgement and path deduction. Then the processed data is transmitted to the mobile APP and rescue device, which is convenient for the rescuer to understand the situation of the people at the edge of the water and in the water in time.

4.3 DISPLAY MODULE

The mobile APP in the system is developed using the APP Inventor 2 web platform. APP Inventor 2[12] is a completely online development Android programming environment, which does not require professional programming knowledge, but only simple code splicing according to your needs. In this paper, according to the existing APP operation page, design the operation page to meet the user's needs, click on the APP icon, enter the initialisation interface, select the server to connect, as shown in Figure 6.

Mobile APP has the ability to receive and store data from the front-end equipment. Users can use APP to understand the situation of the waters in real time, generate relevant data statistics and reports, analyse the trend of drowning events, rescue efficiency and other statistical information to help improve the monitoring system and rescue strategies.

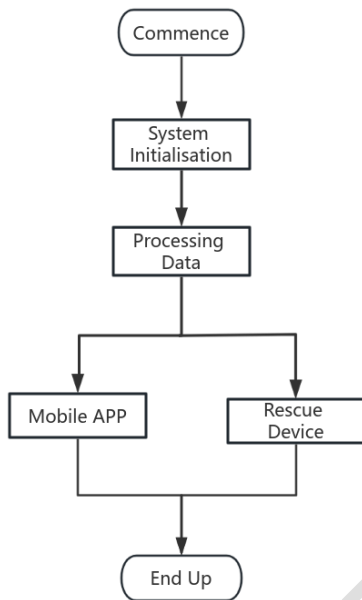

Fig. 6. Flowchart of the main control unit programme

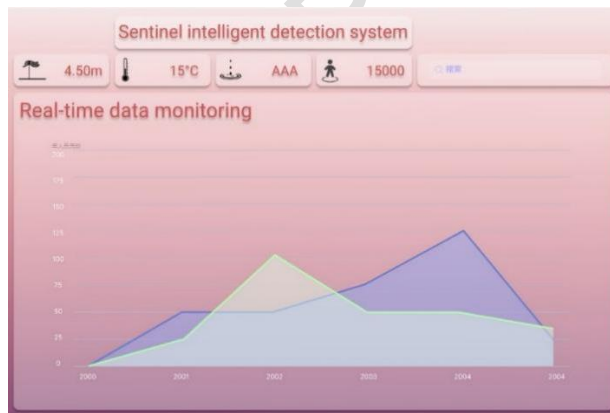

Fig.7. Mobile APP page

5. CONCLUSION

In this paper, we designed an all-in-one drowning prevention and monitoring system based on Open Cv, relying on Raspberry Pi, through the integration of multiple modules, we designed

a system that can monitor the situation of the water in real time, such as a person who is about to enter the water can be automatically issued a warning reminder, and when the detection of the occurrence of the incident of falling into the water can be automatically sent out an alarm and notify the neighbourhood rescue team, and at the same time, activate the rescue device in order to ensure that the life of the person who has fallen into the water is safe. The system has been verified through actual testing, and the test data meets the design requirements. The test results show that the system can work stably and efficiently, which can greatly reduce the risk of drowning accidents, and has good promotion prospects and application value.

REFERENCES

1. World Health Organization. drowning [EB/OL]. [2022]. <https://www.who.int/zh/news-room/fact-sheets/detail/drowning>.
2. Wang Xiaoyu,Hou Xinmiao,Wang Jiachang,et al.2022 China's youth drowning prevention big data report [R]. Beijing:People's Daily Opinion Data Centre, 2022.
3. Dai Xinghua,Zhang Yanwei. Practice and exploration of early warning mechanism for drowning prevention[J]. Science Consultation(Educational Research),2019(07): 24.
4. Su Y. Research on Building construction fire safety management based on image recognition technology [D]. Chongqing university, 2022. DOI: 10.27670 / , dc nki. Gcqu. 2021.000382.
5. Deng J, Wang Shoufeng, Huang Xiaoping, et al. Water quality on-line detection system based on STM32 design [J]. Journal of electronics, 2023, 31 (18) : 7-10 + 19. DOI: 10.16589 / j.carol carroll nki cn11-3571 / tn. 2023.18.018.
6. GUO Xunwen,FENG Yan. Dual-mode mobile phone remote control lifebuoy based on Wi-Fi technology[J]. Modern Information Technology,2022,6(19):146-149.DOI:10.1985 0/j.cnki.2096-4706.2022.19.035.
7. Dong Zhenhua, HE Miao. Pedestrian Detection System Based on OpenMV [J]. Science and Technology Innovation,2023(24):92-95.
8. Li Rongrong. The design of the automatic shower water control alarm system [J]. Journal of electronics, 2023, 31 (17) : 86-89. The DOI: 10.16589 / j.carol carroll nki cn11-3571 / tn. 2023.17.018.
9. Zhang Wei, Yang Shenshen, He Weiwei, et al. Research on DC brushless Motor Drive control of deep-sea manned submersible [J]. Ship Science and Technology, 2019,46(01) :126-131.
10. Zhang, D. W.. Application of visual inspection system based on OpenCV[J]. Mechanics Information,2024,(01):7-10.DOI:10.19514/j.cnki.cn32-1628/tm.2024.01.002.
11. Jia Shuangying,Yang Chunle. Research on children's drowning prevention test based on OpenCV and CNN[J]. Computer and Telecommunications,2023(08):85-89.DOI:10.15966/j.cnki.dnydx.2023.08.003.
12. Yang Kaiyi, Liu Zhongwang, Wang Chuqiao, et al. Research on the development of veterinary assisted clinical diagnosis APP based on Turing robot [J]. Chinese Journal of Veterinary Medicine, 2019,56(02):42-45.