

Design and Development of Automatic Universal Chain Type Vegetable Transplanter

ABSTRACT

Many crops such as Lettuce, Spinach, Broccoli, Cabbage, Cauliflower, Tobacco, Eggplant, Herbs, Pepper, Tomato, Watermelon, Onion, Garlic and Sweet Potatoes, are best grown by growing seeds in a controlled environment and then transplanting seedlings to the field. Transplanting methods have dramatically improved in recent years, but are still very labour intensive. Mechanization of Feeding of the seedlings on vegetable transplanter face many restrictions due to non-uniformity in shape and size of the seedlings and different transplantation spacing requirement, since the yield of various crops are determined by spacing of the seedlings. Even today, many transplanting methods rely on human labour to place seedlings directly into a planting mechanism and to determine the correct spacing.

There exists a need for a high-speed transplanter which can feed the seedlings to the transplanting unit and transplant the seedlings at uniform predefined spacing. Plant tape could be the solution to the above discussed problems, seedlings loaded onto a tape that is relatively simple to operate with low labour costs. Design that depends on principle of pulling a tape already anchored in the ground. It requires a tape material which can withstand significant tensile stress, especially at high speeds of planting. Thus, a need exists for a feeding system which can be feed into high-speed transplanter designed to exert low tensile stress on the tape. Preferably, the tape should be biodegradable (to avoid adverse soil health) having very high tensile strength.

This project would enable the farmers to plant the seed/plant tape manually/mechanically and to do so rapidly, thereby quickly disposing the seed/seedlings at precise depth, properly oriented and at correctly spaced intervals. This can be achieved in certain steps, which involves the steps of unwinding the honeycomb arranged plant tape in seedling tray, making furrow in the ground, placing it in furrow in the ground, and pressing it firmly in furrow. Plant tape would save around 50% of the cost of transplantation, saves 80% of transplantation cost by transplanting at six times faster speed than traditional methods.

Keywords: Seedling tape, Pot type transplanter, Chain Type transplanter, vegetable transplanter, Universal Transplanter

INTRODUCTION

India is the second largest producer of vegetables and fruits in the world covering total area of 24.19 million ha under horticultural crops with production of 277.35 million tons (NHB, 2014). India produces 146.55 million tonnes which is 14% of world's vegetables on 8.5 million hectares which is around 15% of world area under vegetables (Vanitha et al., 2013). Productivity of vegetables in India(17.3t/ha) is less than average productivity of vegetable in world(18.5t/ha).

In vegetable cultivation, the crops like onion, tomato, brinjal, chilli, cabbage, cauliflower etc. are raised in the nursery. The seedlings are usually uprooted and transplanted on raised beds in fields when seedlings are of about 30 to 40 days. Seeding and transplantation operations in India which accounts for approx 40% of total working hours of cultivation which are mostly performed manually. The usual practice is to hold a bunch of seedlings in one hand and separate one seedling by the other hand and press down the roots in the soil with fingers. The work is very tedious and laborious as the operation is done in bending posture which also poses threat of many musculoskeletal disorders to agricultural workers.

In manual transplanting of vegetable seedlings, labour requirement is very high, as high as 253 man hr per ha (Satpathy, 2003; Kavitha, 2007). The transplanting operation should be completed as early as possible after removing the plants from the nursery (Chauhan, 2000). Vegetable crops like onion are very sensitive to climatic

conditions and require timely operations. However, there is shortage of labor causing delay in transplanting during peak season which finally results into reduction in yield of crop (Chaudhuri et al., 2002; Kavitha, 2007).

Among the various cultivation practices followed for raising vegetable crops, transplanting of good quality vegetables seedlings at appropriate depth, spacing and sufficient soil cover around the seedlings is one of the most important operations. Ridge Planting and Flat-Seedbed planting methods are mostly used for manual transplantation of bare-root seedlings of vegetable in farms with medium and large-scale vegetable production. In small scale vegetable gardening, pits of appropriate size are dug and seedlings are manually planted in the pits. Manual transplanting of seedlings are non-uniform in plant distribution although it is expensive, time consuming and labor intensive. Thus to overcome these problems, use of mechanical/automated transplanter is highly essential.

Attempts have been made by various research institutions under the Indian Council of Agricultural Research, New Delhi to develop tractor mounted 2-row and 3-row semi-automatic vegetable transplanters for bare-root and plug seedlings. The transplanters for bare-root seedlings mostly employ pocket-type or rotary cup type metering units. Machine with Pocket-type metering unit machines have forward speed of 0.8 to 0.98 km/hr, field capacity of 0.082 to 0.092 ha/h and labor requirement of 36.58 to 44.4 man-h/ha. The machines with rotary cup type metering units had the forward speed, field capacity and labour requirement of 1.4 km/h, 0.14 ha/h and 28.6 man-h/ha respectively. Although both machines had good quality of transplantation, they were reported of high labour requirement and low field capacity. Additionally, two labours are required to feed the missed plantings of seedlings in case the speed was increased to maintain acceptable missed seedlings percentage.

Many crops such as onions, lettuce, spinach, tomatoes, tobacco and sweet potatoes, are best grown by growing seeds in a controlled environment and then transplanting seedlings to the field. Sweet potatoes, whose every part, including roots, vine, stem and leaves are edible is ranked at sixth position of largest produced crop in the world. It is not grown widely since its harvesting process is very labour intensive. Whole Sweet potatoes are first planted in bed, until seedlings are grown to a particular height (preferably 8-12 in) then-after seedlings are transplanted into field, clipped one inch about the level of ground.

Transplanting methods have dramatically improved in recent years, but are still very labour intensive. Mechanization of Feeding of the seedlings on vegetable transplanter face many restrictions due to non-uniformity in shape and size of the seedlings and different transplantation spacing requirement, since the yield of various crops are determined by spacing of the seedlings. Today, to maintain uniformity and proper desired spacing, many transplanting methods rely on manual human labour to place seedlings directly into a planting mechanism.

The conventional Planting techniques are associated with many problems which could be disadvantageous in terms of environmental concern as well optimum rate and uniformity to control as population density of crop for efficient production. Crops such as Lettuce are usually planted imperfectly too thick for plants to have sufficient space for proper growth of crops. Even conventional row crops are seldomly dispensed at desired rate and uniformity.

The automatic seedling feeding mechanism could be achieved in two ways. First method is to grow the seedlings in seedbed or a container. Then these seedlings are extracted from seedbed and planted in field or individual container is planted along with the seedlings. The second method is to extract the seedling and load the seedlings on a tape round a spooling device for transplantation. Second method of extracted seedlings is usually more economical as compared to other method of individual container method. Additionally, fertilizers and herbicides can be applied to tape which is being planted along with the seedlings. Different methods have been developed to attach the seedling around the tape and thereafter winding it over the spool, once the tape is wound around the spool, it can be placed firmly in soil mechanically, thus ensuring uniformity in crop density and proper spacing of the crops for optimum growth.

The process explained above is significant in maintaining uniform pre germination of seeds and automating the plantation. The foresaid methods can be used for plantation of both seeds as well as seedlings. In case, the plant

tape is used for seeds it can be easily mounted on planter, requiring simple unwinding mechanism and tape can be placed in furrow horizontally. However, if the plant tape consists of seedlings, then the seedling needs special care and protection, since the seedlings are delicate and are usually extended beyond the tape limits. Also, the seedlings must be placed vertically in the furrow which demands more complicated mechanism for tape unwinding.

There exist need for a transplanter which is easy to operate, faster and low labour intensive for seedlings wound on tape. The tape should be preferably biodegradable and must poses high tensile strength specially at high speed, since tapes are already anchored on ground and transplanter pulls tape exerting high tensile strength.

Problem Statement

Vegetable Most of the Indian Farmers produce vegetable in small farms and transplantation is mostly manual and labour intensive. In Peak season, unavailability of agricultural workers, puts risk and challenges for farmers. Recent advancement in **Mechanization of transplantation operation, involve majorly tractor pulled transplanters. Manual Transplantation also involve repetitive prolonged awkward posture which pose high risk of musculoskeletal disorder.** Thus there exist a need of transplanter which is compact, lightweight, economical, effective and ergonomically fit for vegetable transplantation.

1.1. Justification

- **Efficiency:** Plant Tape gives better density of seedling per unit tray as compared to standard conventional seedling trays, thus maximizing efficiency at every level of operation, germination, greenhouse and transportation. Also this cut down seed cost, transportation cost and labour cost in field.
- **Quality:** Plants are germinated under ideal conditions in the greenhouse under ideal conditions. Thenafter, Seedlings are transplanted in the field along with the Seedling-tapeat desired optimum spacing without damaging the roots **of the plants, resulting into uniform, healthy and high-quality crops.**
- **Flexibility:** seeds are sown under dry condition in Seedling-tape, so germination can be controlled by **introducing water to plant tape, when required.** Since, seeding are germinated and planted along with Seedling-tape, seedling need not to be plug from bed, which gives farmers flexibility of transplanting at any level of maturity, i.e.,ranging from initial germination days to a fully developed seedling. This flexibility proves advantageous in logistics and planting schedules.
- **Sustainability:** Seedling-tapeutilizes less water and peat as compared to conventional transplanting. Also, all materials are biodegradable.

MATERIALS & METHODS

This transplanter enables the farmers to plant the seed/seedlings manually/mechanically and to do so rapidly, thereby quickly disposing the seed/seedlings at precise depth, properly oriented and at correctly spaced intervals. It involves the steps of unwinding the plant tape from a spool or core, putting it in furrow in the ground, and pressing it firmly in place

The major crops which are economical to be transplanted are Lettuce, Spinach, Broccoli, Cabbage, Cauliflower, Tobacco, Eggplant, Herbs, muskmelon, **Pepper, Tomato, Watermelon, Onion, Garlic and Sweet Potatoes.**

Different vegetable types need different amounts of free space to ensure healthy growth and a good crop. Based on the required plant Spacing data, Seed or plants are to be spaced on the Plant tape and thus these data play very crucial role in design of plant tape for width and height of individual plant tape. Plant Spacing chart ensures sufficient room for growth your vegetable plants.

Development of seedling plant tape transplanter comprises of two stages, stage 1 is development of seedling tape preparation table and stage two deals with the design and development of transplanter which could hold the seedling, transplant the seedling tape in soil.

Results and Discussion

3.1. How does seedling-tapeworks?

The Plant tape works in 5 steps, in a same sequence as mentioned below,

1. Construct Seedling-tape
2. Insert seeds
3. Pack into special trays until germination
4. Load into Plant Tape transporting machine & transfer to field
5. Plant directly into soil

3.1.0. Seedling-tapeTable Design

Table design for construction of plant tape depends on various factors

- Plant to plant spacing
- Depth of plantation
- Size of seed/bud
- Width of teabag filter roll

Considering onion, Garlic and lettuce for transplantation in this study, the table is designed for Dimension (100cm X 40cm). The Table should be designed such that un-mounting should be smooth and easy without damaging the shape of seedling-tape plug or puncturing/tearing-off the material of plant tape. To make the plant tape flexible in folding and to un-mount plant plug at end, stainless steel door hinge is attached at starting each crest portion of plant table, as shown in Fig 1.



Figure1: Seedling-tape Table

3.1.1. Construct Plant tape

Construction of Plant tape is major task of this project it consists of 2 layers of biodegradable paper. Plant tape uses growing medium which consist of mixture of coco-peat and vermiculite. This growing medium is sandwiched between two biodegradable tissues to form a tape like structure.

This can be done by placing Biodegradable paper on seedling-tape table in such a way that it takes the shape of top surface of Seedling-tape table. Then-after the growing medium is filled in the trough portion of Seedling-tape table. Another layer of biodegradable tape is used to sandwich the growing medium, and heat is applied on

the crest portion of table to seal the two layers(Material used to construct plant tape is heat sealable). Refer Fig 2 for constructed plant tape.

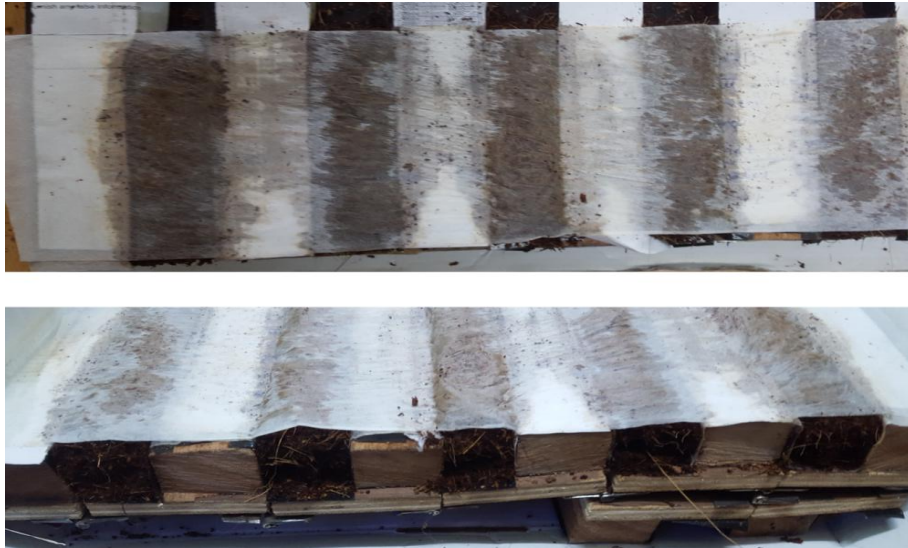

Figure2: Construction of Plant Tape

3.1.2. Insert seed

The tape like structure formed above is brought to punch perforation unit where the growing medium block is punched hole and each holes are filled with desired seed for and stored dry. Seed can also be inserted manually using Seed Filling Tray or conventional manual seed dropping technique.

3.1.3. Pack into special tray until germination

After sowing seed it is then cut into individual tape. the line of tape are then packed in a zigzag formation into plastic trays specially designed for transplanting system where it can be wetted and allowed to germinate. Refer Fig 3 for packed tray schematic and arranged plant tape on tray.

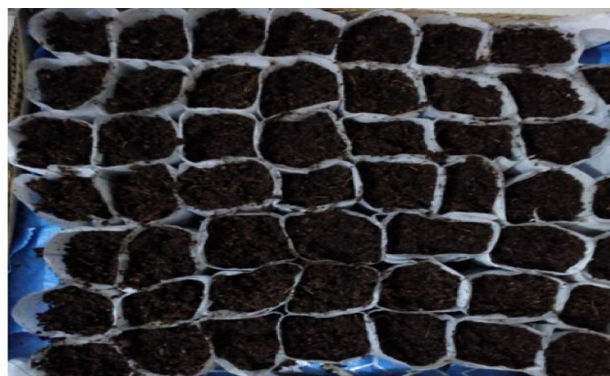
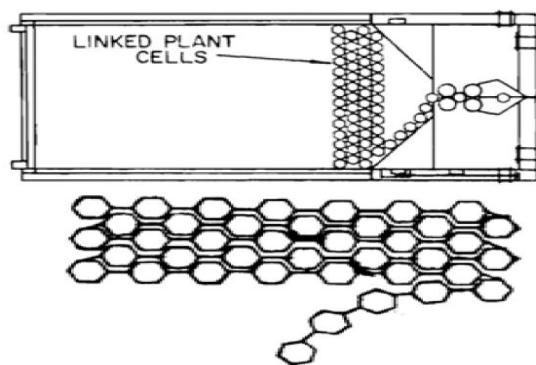

Figure 3: Plant Tape arranged in Tray

3.1.4. Load into Plant Tape transporting machine & transfer to field

The germinated seedling tray can be transported to field in the trays. The transportation is very easy and damage free. Since the seedlings are directly planted without removing the growing medium, it provides the flexibility to plant over a range of time period. Fig 4 shows plant tape tray ready for transportation.



Figure 4: Plant Tape ready for transplantation

3.1.5. Plant directly in soil

Trays are then mounted on plant transplanting machine. One end of the plant tape is affixed to ground. The transplanting machine consist of a furrow at its bottom frame, which is adapted to open the soil in which the seed tape is placed because of pull force exerted on it when transplanting machine is pulled back. Refer Fig 5.



Figure 5: Schematic of Plant Tape Transplanter and Plant tape

3.2. Plant Tape Transplanter

Seedling contained in tray can be transplanted in field manually or using specially designed transplanter for Seedling-tape and Paper-pot. The transplanter opens a furrow in the field when it is pulled back and transplants the plant tape because of pull force exerted on it since its one end is affixed to the ground. Refer Fig 6 for schematic view of Plant tape transplanter

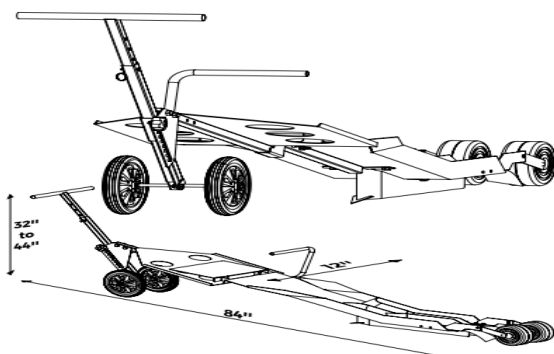

Figure 6: Plant Tape Transplanter

Design of Transplanter:

1. Force Required Pull load weight on transplanter

The total load on transplanter is due to the weight of the frame and the total weight of pots in the trays

Considering total static weight of frame to be 7 Kg and total pots on transplanter to be 150, with each pot weighing 65g.

$$\text{Total Weight on tray} = 65 \times 150 = 9.75 \text{ Kg}$$

$$\text{Total load on transplanter} = 7 + 9.75 = 16.75 \text{ Kg}$$

Since load is equally distributed on two front wheels

i. Force required to overcome rolling resistance offered by loose soil on Front Wheel

$$F_1 = f.W_1 / r_1 = 72.95 \text{ N}$$

ii. Force required to overcome rolling resistance offered by loose soil on Rear Wheel

$$F_2 = f.W_2 / r_2 = 137.34 \text{ N}$$

iii. Draft Force required to open furrow

$$D = K_o \cdot w \cdot d$$

Where D = draft Force, kgf

K_o = Specific soil resistance

W = width of furrow opener, cm

D = depth of furrow opener, cm

$$D = F_1 = 0.25 \times 45 \times 40 = 176.58 \text{ N}$$

iv. Overall force required by farmer to pull the Transplanter

$$\text{Total Force required} = F_1 + F_2 + F_3$$

$$= 72.15 + 137.34 + 176.58 = 386.07 \text{ N}$$

v. Resultant pulling Force

Since handle is attached at an angle of 45° , the resultant force required on handle to pull the transplanter

$$= (F_1 + F_2 + F_3) \cos 45^\circ$$

$$= 203.106 \text{ N}$$

2 Design of handle

Let the length of handle be 400mm made of galvanized steel material ($\sigma = 55000 \text{ psi} / 379.21 \text{ MPA}$).

Since handle is subjected to tensile stress.

$$\text{Allowed stress } \sigma_{Al} = FOS * \sigma_{yl} = \frac{R}{A_1}$$

$$A_1 = \frac{R}{FOS * \sigma_{yl}}$$

Considering Factor of Safety as 2

$$A_1 = 0.26775$$

Allowed diameter of handle rod $D = 0.0213$ m or 2.13 cm

Therefore, 1 inch diameter of galvanized rod of length 400mm is safe for design

3 Design of tray

Design of seedling tray size, for tray of material MS Steel 20 Gauge, having yield strength of 150 MPa.

Total seedlings on transplanter to be 150, with each seedling weighing 65g.

Total Weight of seedlings on tray = $65 \times 150 = 9.75$ Kg = 10kg approx.

Total force exerted on tray = 9.81N

$$\text{Compressive Stress on tray} = \frac{F_o}{A}$$

$$\text{Allowed stress } \sigma_{Al} = FOS * \sigma_{yl} = \frac{98.1}{A}$$

$$A_{all} = 0.218 \text{ mm}^2$$

$$\text{Area of tray} = 600 * 400 = 240000 \text{ mm}^2$$

Since area of tray is greater than allowable Area, Design is safe.

4 Design of shaft

Let the material of Shaft be MS Steel, having shear stress 34N/mm^2

Torque of shaft of transplanter, $T = F * R = 91.3977$ Nm

$$\text{Torque } T = \pi \sigma_s \frac{d^3}{16} * \frac{1}{FOS}; FOS = 2$$

$$d^3 = 13697 \text{ mm}$$

$$d = 23.92$$

therefore, shaft of diameter 30mm is safe for design

5 Theoretical number of plants transplanted/min

Theoretical number of plants transplanted per minute, is dependent on number of cutting fingers used in transplanter. Considering transplanter is pulled by a man, with average walking speed of 1.5Km/hr

$$\text{Speed} = v = \frac{2\pi N}{60} * R \quad \text{where } R = \text{radius of driving wheel}$$

N= 8.82 rpm or 8.82 times per minute

No of plants transplanted per min theoretically = $8.82 * n$ where n = no of cutting Fingers

For Cutting fingers = 1, number of plants transplanted = 8.82 or Approx 9

For Cutting fingers = 2, number of plants transplanted = 17.64 or Approx 18

For Cutting fingers = 3, number of plants transplanted = 26.46 or Approx 26

For Cutting fingers = 4, number of plants transplanted = 35.28 or Approx 35

For Cutting fingers = 6, number of plants transplanted = 52.92 or Approx 53

For Cutting fingers = 8, number of plants transplanted = 70.56 or Approx 71

Therefore theoretically minimum 17 plants can be transplanted per minutes and with 8 blades, maximum 71 plants can be transplanted per minutes.

SUMMARY AND CONCLUSION

Seedling Tape, an automated transplanting system proves to be significantly more efficient as compared to conventional transplanting methods in terms of productivity, less labour intensive and high speed of operation. Seedling-tape which uses proprietary and unique plant tape plugs containing growing medium and seed, integrates process of sowing, germination, nursery, and transplantation in field.

Seedling Tape plugs comprises of biodegradable tissue and growing medium which consists of a mixture of cocopeat and vermiculite sandwiched between two layers of biodegradable tissue. This sandwiched layer are such shaped to form a continuous tape like structure of seedling plugs and arranged in specially designed tray in a zigzag manners for easy unwinding. Trays are then watered when germination is required which triggers the germination process and seedlings starts to grow normally in the plug of the Seedling-tape. Plants can be transplanted at any stage after germination. For Transplantation, the Tray is mounted on the transplanter, the planting module, pulls the Seedling-tape and places the plugs accurately in furrow at uniform desired space. The Tape is either cut to maintain space or is plants continuously depending on the crops spacing requirements.

Seedling-tape provides a greater density of plants per tray than the standard plug system, which maximizes efficiencies at all levels of an operation; germination, greenhouse, and transportation. Transplanting increases stand counts, reduces seed costs and the faster and easy transplanter minimizes the need for additional labor in the field.

The feasibility of the project can be proved easily proved by 50% saving on cost, 80% saving of time, ease of operation, quality and productivity. Thus, it proves to be faster than traditional transplanting methods by 6 times and is a true space saver in nurseries with 2,500 plants per square meter versus only 750 plants with traditional transplanting methods. The Transplantation time is also reduced significantly with speed of transplantation upto 71 plants per minute.

REFERENCES

Anonymous. 1993-94. India, DESS, Krishi Bhavan, New Delhi, pp. 78-79

Anonymous. 2004. Annual report 2003-2004. Pp 14-15. National Research Centre for Onion and Garlic, Pune, Maharashtra. Pp.14-15.

- A khadatkar, S M Mathur, B B Gaikwad, 2018. Automation in transplanting: A smart way of vegetable cultivation. Current Science, Vol 11. No. 10, 2018
- A khadatkar, S M Mathur, B B Gaikwad, 2018 Biometric Properties of plug seedlings relevant to the design of vegetable transplanter. Journal of agricultural engineering Vol 57(1) 2020
- A Ray, A Kumar et.al. 2018. Farm Mechanization and energy consumption for different farm categories of Phaphamau region. Trends in biosciences 11(48) : 0974-8431, 2018
- B M Nandede, H Raheman 2015. Multistage Metering Mechanism for transplanting of vegetable seedling in paper pots. The Institution of Engineers (India) 2015
- B M Nandede, G Carpenter, R Chillur, M L Jadhav 2017. Development of a low cost manually operated two row vegetable transplanter. International journal of tropical agriculture: 0254-8755
- Bahnasawy, A. H. 2007. Some physical and mechanical properties of garlic. Int. J. Food Engg. 3(6): 1-18.
- Boa, W. 1984. The design and performance of an automatic transplanter for field vegetables. Journal of Agricultural Engineering Research. 30(2): 123-130.
- Brewer, H. L. 1990. Experimental static-cassette automatic seedling transplanter. Paper- American-Society-of-Agricultural-Engineers. 14: 90-1033
- Brewer, H. L. 1994. Conceptual modeling automated seedling transfer from growing trays to shipping modules. Trans. of ASAE. 37(4) : 1043-1051.
- Central Institute of Agricultural Engineering. 2004. Report of the all India coordinated research project on farm implements and machinery. Bhopal, India.
- Chaudhari, D., Singh, V.V. and Dubey, A.K. 2002. Refinement and Adoption of Mechanical Vegetable Transplanter for Indian Condition. Agril. Engineering Today. 26(5-6) : 11-20.
- Chaudhari, D., V.V. Singh and A.K. Dubey. 1999. Final report on survey of existing status of seeding/ planting methods and determination of mechanization needs for planting of important vegetable crops in India, Central Institute of Agricultural Engineering, Bhopal.
- Chauhan, D.V.S. 2000. Nursery management and transplanting. Vegetable production in India. Ram Prasad and sons, Agra -3:51-57.
- Choi W. C., Kim D. C., Ryu I. H., Kim K. U. 2001. Development of a seedling pick-up device for vegetable transplanters. Trans. of the ASAE. 45(1) : 13-19.
- Choon, Y.K. 1992. Mechanization in transplanting of vegetable seedlings. Agriculture Engineering and Rural Development. Proceedings of a conference held in Beijing, China on 12-14 October. Vol. I. International Academic publisher; Beijing; China.
- Compton, B.A. Reid and W.S. Reid. 1986. An automatic media-block transplanting system. Eng. 8 Stat. Res. Centre, Research Br., Agric. Canada, Rept I-924 , 31 pp.
- De Groot, P.F. 1986. "Recent Innovations in the Stabilized Soil Plug Automatic Transplanter". ASAE Paper No. 86-1019

Dharamraj M, Mounesh M 2020. Design and Fabrication of Paper Pot Transplanter. International journal of Scientific & Technology Research Volume 9, ISSN 2277-8616.

FAOSTAT. 2013. Agricultural data, agricultural production, crop primary. <http://faostat.fao.org/faostat>

Foxdrive, R. 2007. Studies on semiautomatic leek and onion transplanter, Z. I. R. Far Industrial Farm Equipment Bradford Ontario.

Gaikwad, B. B. 2010. Design and development of plug seedling transplanter for vegetable crops. PhD thesis. IARI, New Delhi-110012.

Garg, I. K. and Dixit, A. 2002. Design and development of tractor operated vegetable transplanter. Paper presented in 24th workshop of all India coordinated research scheme on farm implement and machinery (ICAR) held at Tamil Nadu Agricultural University (TNAU), Coimbatore on 18-21, April.

G V Prasanna Kumar, H Raheman, 2008. Vegetable transplanters for use in developing countries. International Journal of vegetable science, vol 14(3) 2008

G V Prasanna Kumar, H Raheman, 2008. Development of walk-behind type hand tractor powered vegetable transplanter for paper pot seedlings. Biosystem Engineering 110(2011) 189-197

Ghadge, S.B., Jadhav, R.T. and Paithankar, K.K. (2008). Design, development and performance evaluation of 35-50 hp tractor operated onion transplanter. Paper presented in 27 workshop of All India Coordinated Research Center on Farm Implements and Machinery (ICAR) held at Indian Institute of Technology, Kharagpur, India on 18-21 December.

Government of India. 2002. Agricultural census 2002. Ministry of Agriculture, Agricultural Census Division, New Delhi, India.

Gutiérrez, C., Serwatowski, R., Gracia, C., Cabrera J. M. and Saldaña, N. 2009. Design, building and testing of a transplanting mechanism for strawberry plants of bare root on mulched soil. Spanish Journal of Agricultural Research 7(4): 791-799

Hauser, V.L. 1985. "An Automatic Grass Transplanting Machine". Trans. of the ASAE, 2806-1777.

Hayashi, S., Ota T., Kubota K., Kinoshita E and Yamamoto K. 2006. A planting machine for chrysanthemum cuttings with a supply mechanism using rotating cups. Japan Agricultural Research Quarterly. 40 (1): 71 – 78

Imad, H. 1995. Design and field evaluation of a low cost crop transplanter with multiple seedlings feed. Agricultural Mechanization in Asia, Africa and Latin America, 26(3):29-32, 34

Kavitha R., Duriasamy V.M., Kannan B. and Ravindra Naik. 2007. Feasibility and sensitivity analysis of semi automatic plug type vegetable transplanter by "Transprice" programme. IAEC-AIT Bangkok. Kazmeinkhah, K. 2007. Determination of Energetic and Ergonomic Parameters of a Semi-automatic Sugar-beet Steckling Transplanter. J. Agric. Sci. Technol. 9: 191-198

Kazmeinkhah, K. 2007. Determination of Energetic and Ergonomic Parameters of a Semi-automatic Sugar-beet Steckling Transplanter. J. Agric. Sci. Technol. 9: 191-198

K Lokesh, H Raheman, S Vikas 2020. Design and development of a tractor drawn automatic onion transplanter. International journal of current microbiology and applied sciences 9(2): 2616-2629

- Munilla, R.D. and Shaw L.N.. 1987. A high speed dibbling transplanter. *Trans. of ASAE*. 30(4) : 904-908
- Mohanty, S. K. Mishra, J. N. and Ghoshal, M. K. 2012. Ergonomical evaluation of paddy transplanting operations in Odisha. *International journal of agricultural engineering*. 5(2): 153-157
- More, P. S. 2008. Tractor drawn onion transplanter. PP. 1-2. www.nif.org.in
- Nambu, T. Tanimura, M. 1992. Development of automatic transplanter using chain pot for vegetable crops. *Acta horticulturae*. Oct. 2(319): 541-546
- Narang, M. K. Dhaliwal, I.S. and Manes, G.S. 2011. Development and evaluation of a two-row revolving magazine type vegetable transplanter. *Journal of Agricultural Engineering*: 48(3)
- National Horticultural Board (NHB). 2014. Indian Horticulture Database. Ministry of agriculture, Government of India. <http://nhb.gov.in/default.aspx>
- Ojha Pragya and Seema Kwatra. 2012. An ergonomic study on human drudgery and musculoskeletal disorders by rice transplanting. *Stud Home Com Sci*, 6(1): 15-20
- P Kaushik, N Manohar, B Niranjana, 2020. Design and fabrication of manually operated paper pot plant transplanting machine. *International journal of engineering and technology* volume 7: 2395-0056
- Parish, R.L. 2005. Current developments in seeders and planters for vegetable crops. *Hort. Technology* 15(2):1-6.
- Punjab Agricultural University. 2004. Report of the all India coordinated research project on farm implements and machinery. Department of Farm Machinery and Power, Punjab Agricultural University, Ludhiana, India
- Pinkepank, W.R. and L.N. Shaw. 1980. "An Automatic Vegetable Seedling Soil Block Transfer System". ASAE Paper No. 80-1054.
- Prasanna Kumar, G. V. and Raheman, H. 2008. *International Journal of Vegetable Science*. 14(3): 232-255.
- Prasanna Kumar, G. V. and Raheman, H. 2011. Development of a walk-behind type hand tractor powered vegetable transplanter for paper pot seedlings. *Biosystem Engineering*. 1-9.
- R Chilur, B M Nandede, P S Tiwari, 2018. Development of auger conveyor type metering device for transplanting of vegetable seedlings raised in paper pots. *Tropical Agricultural Research* vol 29 (4): 258-370 2018
- Sadhu, R. R. 1982. Development of an onion-set planter based on design criteria of plant transplanters. Master of Science thesis in Agricultural Engineering. Texas Tech University.
- Satpathy S. K. and I. K. Garg. 2008. Effect of selected parameters on the performance of a semi automatic vegetable Transplanter, *Agricultural Mechanization in Asia Africa and Latin America*. 2 : 39.
- Satpathy, S. K. 2003. Effect of selected parameters on the performance of a vegetable transplanter for different crops. Unpublished M.Tech Thesis, Punjab Agricultural University, Ludhiana, India: 94-97

Srivastava, A.K., Goering, C.E., Rohrbach, R.P. and D.R. Buckmaster. 2006. Engineering Principles of Agricultural Machines. ASABE. St. Joseph, Mich

Statewide area and production data. 2011. National Horticultural Research Development Foundation (NHRDF). Nasik. <http://nhrdf.org/en-us/AreaAndProductionReport> status of seeding/ planting methods and determination of mechanization needs for planting of important vegetable crops in India, Central Institute of Agricultural Engineering, Bhopal.

Suggs, C.W. Lineberger, B.M. Mohapatra, S.C. 1992. Automatic feeding transplanter. *Acta horticulturae*. Oct 2(319) : 511-516

Todoric, I. 1972. Investigation on methods of positioning steckling when planting sugar beet. *Agronomrki-Glasnik*. 39(172) : 37-42

Tsuga, K. 2000. Development of fully automatic vegetable transplanter. *JARQ*, Japan Agricultural Research Quarterly. 34(1): 21-28

Turbatmath, P.A. Bhatt, Y.C. and Kadam, P.B. 2011. Development and field evaluation of tractor operated onion transplanter. *International Journal of Agricultural Engineering*, 4 (1): 52 -55

USDA, Natural Resources Conservation Service. 1998. Estimating Soil Moisture by Feel and Appearance. Program Aid Number 1619.

Vanitha S.M., Chaurasia S.N.S., Singh P.M. and Prakash S. Naik. 2013. Vegetable Statistics. Technical Bulletin No. 51, IIVR, Varanasi, pp. 250

Xin Jin, Daoyi Li, Hao Ma, Jiangtao Ji, Kaixuan Zhao, Jing Pang 2018. Development of single row automatic transplanting device for potted vegetable seedlings. *International journal of Agricultural & Biological Science* vol 11 No 3 2018

Xin Jin, Mingyong Li, Daoyi Li, Hao Ma, Jiangtao Ji, Jing Pang 2018. Development of Automatic Conveying system for vegetable seedlings. *EURASIP Journal of wireless communication and networking* (2018) 2018:178

Yadav R., Patel M., Shukla S.P. and Pund S.2007. Ergonomic evaluation of manually operated six-row paddy transplanter. *International Agricultural Engineering Journal*.16 (3-4):-147 -157