

Design and simulation of mobile multi-robot machining platform

ABSTRACT

Today, with the rapid development of science and technology, there are a lot of repetitive labor in people's production and life, and there are many risks when they explore unknown places. To a large extent, the emergence of mobile robots can solve these problems and replace human beings to complete boring tasks and reduce risks. The mobile robot combines the robot with the omnidirectional mobile platform, which greatly increases the activity range of the robot, but the ability of the mobile single robot is difficult to meet the heavy processing tasks and various processes, and the advantages of multi-robot technology are increasingly apparent. Compared with a single robot, it has the advantages of wider task field, strong fault tolerance, strong robustness, low economic cost and flexible distribution.

In this paper, a mobile multi-robot machining platform is designed based on a 6-DOF mobile robot. The mobile robot is composed of an AGV car, a 6-UCU parallel robot and an electric spindle. The three-dimensional model of the mobile multi-robot machining platform established is composed of two isomeric robots, which are symmetrically distributed on the machining platform to lay the foundation for direct coupling. Then the force is added to the mobile multi-robot machining platform in Adams, and the dynamic simulation is carried out to observe the force of each electric cylinder during movement. The modal analysis of the mobile robot was carried out by using ANSYS Workbench software to obtain modal parameters such as natural frequency to verify the rationality of the designed mobile robot. To truly detect the safety hazards. In order to solve these problems, ANSYS (finite element analysis software) is used to analyze the theoretical stress of the 3D structure model, and the theoretical dangerous stress position of the structure is solved. Provide strong data support for the design and development of wind power crane industry in the later stage

Keywords: Mobile robot; Dynamics; Simulation;

1. INTRODUCTION

With the rapid development of robotics, traditional fixed processing robots can not meet the increasingly complex tasks, because mobile robots have the advantages of flexible movement, easy to complex processing, and strong environmental adaptability, making it an important development direction of robots. It provides a solution to the problem of low processing efficiency of mechanical parts, which can enable parts to be processed in situ without repeated testing, assembly and disassembly, but the ability of a single mobile robot is difficult to perform heavy processing tasks and a variety of processes. Therefore, the application of multi-robot technology in modern society is increasingly extensive. Compared with a single robot, the multi-robot system has wider working range, stronger fault tolerance, lower economic cost and more flexible distribution. In the third chapter, the structure design of mobile multi-robot machining platform is mainly carried out, focusing on the structural design of mobile robot part.

The dynamic process of the platform is not considered in the kinematic analysis, because the structure of the model and the arrangement of the actuator are important reasons that affect its dynamic characteristics. The dynamic characteristics of a mobile robot depend on its dynamic equation, while system dynamics mainly studies the relationship between the motion of the object and the force. The movement of the mobile robot processing platform is driven by the driving rod, so

that the platform can complete the corresponding movement. Modal analysis is implemented by ANSYS Workbench software, which is the mainstream finite element analysis software at present. ANSYS has a new engineering view function and a better human-computer interface, which makes the whole simulation process more compact. In the engineering page, the concept of engineering flow chart is introduced into the engineering page, and the function can be applied to connect the problems of multiple fields with multiple problems, so as to achieve the purpose of correlation. Through a simple drag operation, a complex analysis of multiple physical fields can be completed. On the right side of the table, there is a status TAB that prompts the user whether to update, enter, etc., so that the user can easily see the status of its Settings. In chapter four, the dynamic simulation of the mobile multi-robot machining platform is carried out first, and the force and time curves on the six electric cylinders are obtained. Then, the vibration characteristics of the mobile robot structure including frequency and mode are studied by using ANSYS Workbench software.

2. DEVELOPMENT STATUS OF MULTI-ROBOT MACHINING AT HOME AND ABROAD

In our country, many scholars are working on the manufacturing of multi-robot. In order to solve the welding problem of aerospace spacecraft, Zhang Yang et al. [1] designed an automatic brazing system based on KUKA. In this system, KUKA robots cooperate with Roboteam program and use the motion time synchronization mode in KUKA Roboteam program. The whole and automatic process of making holes and riveting is achieved. Zhang Tie et al. [2] carried out constraint analysis on the action of the double robots, and gave the generation of the cooperative action trajectory of the double robots, and tested the algorithm by using the linear motion and circular motion of the double robots. Meng Wei et al. [3] realized the cooperative work of multiple robots by utilizing the division of work and collaboration among multiple robots. The basic structure based on Petri network includes a higher-level controller and a lower-level controller to realize the local control planning of robots.

In the research of 3D modeling and kinematic and dynamic simulation, Ye Renping et al. [4] established 3D modeling of a six-DOF serial robot on Solidworks and introduced it into the kinematic and dynamic simulation software of Adams to test its effectiveness. Adams/Controls interface was used to introduce the virtual prototype into Matlab, Matlab/Simulink was used to establish the model, and a virtual prototype was introduced and applied to the joint simulation system. Li Bincheng et al. [5] took the six-degree-of-freedom parallel mechanism as an example, analyzed the kinematics with Matlab, and obtained the kinematics inversion model of the six-degree-of-freedom parallel mechanism. Li Zhihu [6] used SolidWorks software to build a 3D modeling of the excavator, and applied ANSYS Workbench to carry out the stress-strain analysis of the boom, and compared it to get the optimal boom structure. In order to prevent the mechanical arm of the excavator from working in the frequency segment with excessive deformation and extend the working time of the mechanical arm, the vibration analysis is carried out in the 10-order frequency segment. Yang Jizhi et al. [7] proposed a machining model of the grinding system based on the mobile manipulator. The model and simulation of the system were realized through the coupling design of the process layer, planning layer and system layer, which could avoid interference, improve processing efficiency and optimize the processing flow. GuoXuwei et al. [8] adopted Adams program and took Stewart machine tool as the research object to build a virtual prototype of parallel machinery composed of fixed platform, moving platform, driving rod, platform, etc. Through this model, the kinematics and dynamic characteristics of parallel machinery were simulated, thus providing an efficient analysis method for the engineering design of parallel machinery.

Many foreign scholars have also done a lot of research on multi-robot. Chiacchio et al. [9] proposed a cooperative calculation formula of universal cooperative action according to the absolute and relevant variables of the task, and took PUMA560 as the experimental target to prove the correctness and validity of the algorithm, and extended its contact mode with the terminal actuator to the cooperative action between two manipulators. For the coordination of multiple systems, Andres Montano et al. [10] put forward two methods in this paper: centralized and decentralized. A centralized approach is adopted, with multiple robots as a unit, with a general path plan, to find a cooperative track without interference. The distributed strategy treats each robot as a separate system and uses a collaborative approach to avoid potential conflicts. At the same time, it also points out the contradiction between online control and optimal result in multi-robot control strategy. Ali Tavasoli et al. [11] proposed a mathematical model of dynamic coordination based on the dynamic characteristics of the two time domains. According to the stiffness difference of each system, a variety of control strategies are adopted to prevent the vibration of the flexible beam from being directly detected. The effectiveness of this method is proved by the simulation of the error of its centroid. ParkBumjin; Et al. [12] proposed the concept of multi-robot task assignment, which refers to assigning multiple robots to tasks that maximize the objective function. To solve the problem that the performance of existing meta-heuristic methods deteriorates with the increase of the number of robots or tasks, a Markov decision process model for multi-robot task assignment for reinforcement learning was proposed. Biwei Tang et al. [13] proposed a particle swarm optimization method based on coevolution to deal with the multi-robot path planning problem, and verified the performance of the proposed planning method through different scenarios in the single-robot and multi-robot path planning problems. Numerical simulation results show that the proposed method has a good application prospect in path optimality compared with its competitors. On this basis, Hernansanz et al. [14] designed a

multi-job guidance system based on multiple robots, and realized the cooperation among multiple robots by using the operator's remote control commands. Panzieri et al. [15] used IEKF to estimate the pose information of each mobile robot to realize the cooperative positioning of multiple mobile robots.

3. STRUCTURE DESIGN OF MOVABLE MULTI-ROBOT PROCESSING PLATFORM

3.1 DESIGN PARAMETERS OF KINEMATIC MECHANISM OF PARALLEL ROBOT

The structure diagram of the moving mechanism of the parallel robot is shown in Figure 1

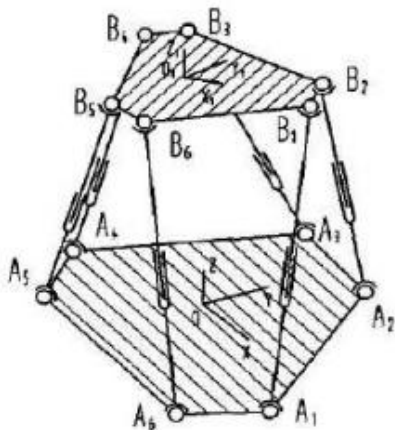

Figure 1 Structure diagram of the parallel robot

The moving mechanism consists of an upper platform, a lower platform, a driving rod and a moving hinge. Establish static coordinate system and dynamic coordinate system. The static coordinate system is on the lower platform, and the dynamic coordinate system is moving with the upper platform. ($i = 1, 2, \dots, 6$) The contact points between the electric cylinders connected to the upper platform and the lower platform (hereinafter referred to as the upper and lower hinge points), respectively, represent the i root electric cylinder. The origin O of the static coordinate system is located at the center of mass of the lower platform, and the origin of the moving coordinate system is located at the center of mass of the upper platform. When the platform is in the initial state, the static and dynamic coordinate systems are consistent, and their height difference h_0 , r , R is the outer circle radius of the upper hinge point and the lower hinge point respectively, and a and b are the center angles corresponding to the short sides of the upper hinge point and the lower hinge point. Table 1 lists the parameters

Table 1 Parameters of a parallel robot

Parameter type	Symbol	Numerical value
On the platform outer circle	r	255mm
Lower platform outer circle	R	368mm
The short side of the upper platform corresponds to the center Angle	a	30°
The short side of the lower platform corresponds to the center Angle	b	30°
Distance of origin of coordinates of upper and lower	h_0	445mm

platforms

The upper and lower platforms
correspond to the Hooke hinge
center distance

l_0

425mm

3.2 ESTABLISHMENT OF 3D MODEL OF MOBILE ROBOT

Compared with a single robot, multi-robot machining can ensure the eccentricity and unify the force of the workpiece. In this paper, isomorphic dual-robot direct coupling machining is adopted, as shown in Figure 2

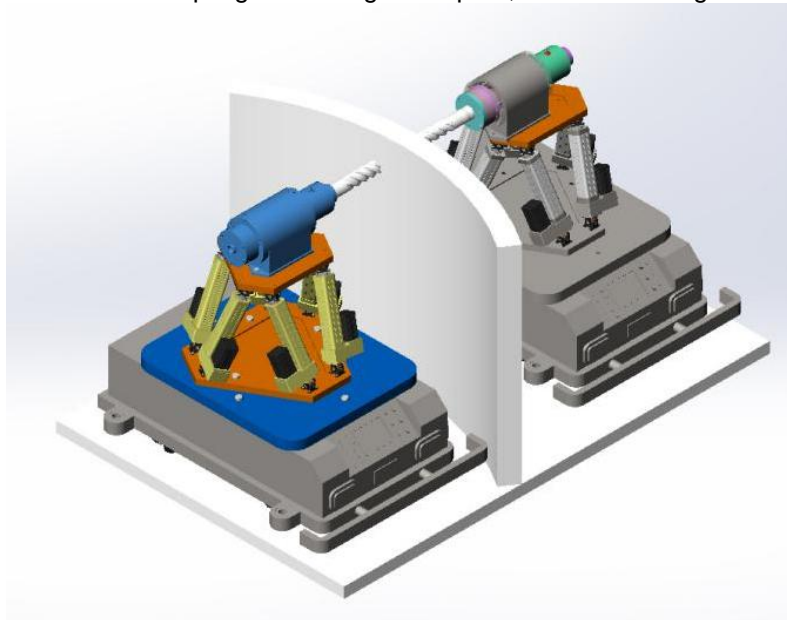

Figure 2 Mobile multi-robot processing platform

4. DYNAMIC SIMULATION AND MODAL ANALYSIS OF MOBILE MULTI-ROBOT

4.1 DYNAMIC SIMULATION BASED ON ADAMS

The kinematic analysis of the platform does not consider the dynamic process, because the structure of the model and the arrangement of the actuator are important reasons that affect its dynamic characteristics. The dynamic characteristics of multi-robot mobile machining platform depend on its dynamic equation, and its dynamic characteristics are the interaction between the motion and the force of the research object.

The movement of the mobile robot processing platform is driven by the driving rod, so that the platform can complete the corresponding movement. Click Save as command in Solidworks general assembly drawing, save Solidworks as Parasolid(x_t) and change the folder name to English letters. Click Save, open Adams software, and file import dialog box appears after entering the Adams interface. Select Parasolid in file type and select x_t file generated in the assembly drawing in file to read to introduce Solidworks established into Adams, then add general motion to the platform, and apply 500N force at the center of mass of the moving platform. The direction is along the negative Y-axis, as shown in Figure 3. In addition, motion pairs are added to each joint pair of the robot, and functions are added to the tool drive to make the tool move in a circular motion. The relationship between the forces on the six transmission levers during the contraction process and the time is obtained. In the post-machining module, the obtained data is retained as spline curve, and the obtained spline curve is used as the driving force of the driving rod. As shown in Figure 3.

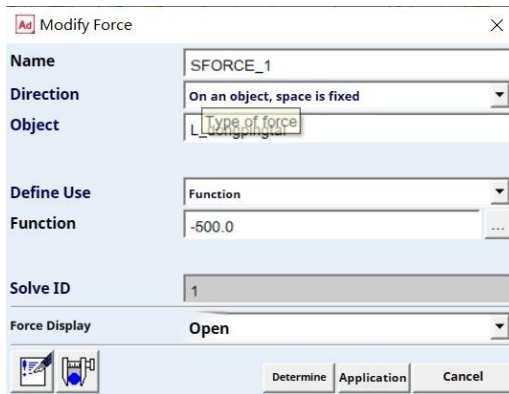

Figure 3 Driver Settings

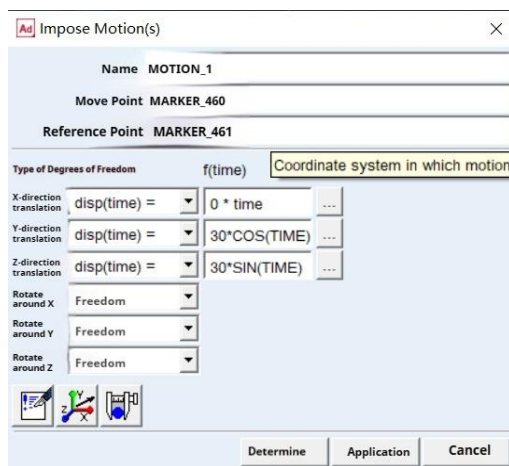

Figure 4 Setting the tool function

In circular motion, the change of the driving force of each electric cylinder is shown in Figure 4

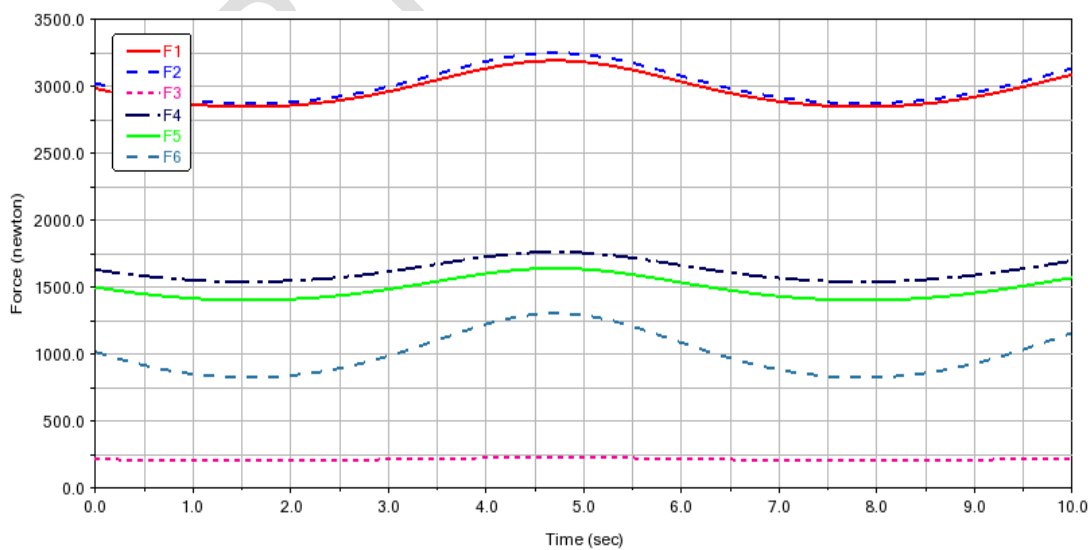

Figure 5 Stress curve of electric cylinder

When the tool moves in a circle, the force of the six electric cylinders in the process of expansion changes periodically, the period is 6 seconds, rod 2 has the largest force in the movement, the maximum strength to bear is 3250N, rod 6 has the smallest force during the movement, and there is almost no change amplitude, and the operation is very stable; The stress of each bar during the overall movement is wavy, the image is smooth, there is no sudden change and bulge during the change process, and there is no impact in line with engineering requirements. Rod 1 and rod 2 have similar forces and larger forces, rod 4 and rod 5 have similar forces and smaller forces. Table 2 lists the force on each electric cylinder.

Table 2 Stress on each electric cylinder

name	Initial loading/N	Maximum load/N	Minimum force /N
L1	2950	3250	2800
L2	3000	3200	2830
L3	240	250	230
L4	1625	1750	1530
L5	1500	1625	1450
L6	1050	1270	800

4.2 Modal analysis based on ANSYS Workbench

Modal method is a method used to study the dynamic performance of structure. It takes its natural frequency and mode as the research object, and it is a system identification technology used in engineering vibration. In this paper, ANSYS software is used to conduct modal simulation of the work of the movable manipulator, and the corresponding structure and structure are obtained according to its natural vibration frequency change curve and the corresponding displacement cloud map of each node, and the corresponding structure is compared with it, so as to eliminate the damage caused by resonance, and prove the rationality and reliability of the platform to a certain extent. It lays a foundation for the application of six degrees of freedom platform in preventing harmonics.

First of all, the model in Solidworks is simplified by Boolean operation, micro-features such as thread chamfering are removed, the connection relationship between various parts is determined, some parts are integrated into the whole, and then the modified model is exported in parasolid (x_t) format, and then imported into ANSYS Workbench to establish the project. Figure 6 shows the model.



Figure 6 ANSYS model diagram

After the mobile robot model was imported, the material was selected first. I chose steel as the default material. Considering the complex shape and large size span of the model set, grid division was carried out for the car and parallel robot respectively, as shown in Figure 7 and 8 after grid division.

Body Sizing
2022/5/20 13:09

Body Sizing

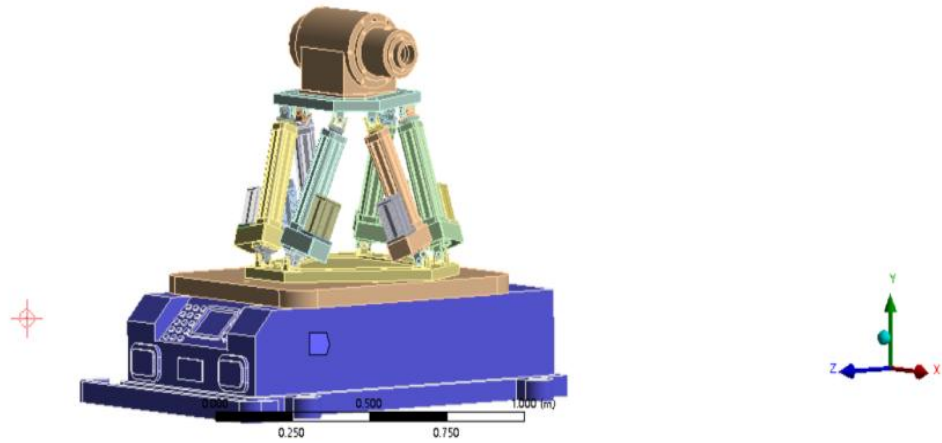

Figure 7 Grid division of the car model

Body Sizing 2
2022/5/20 13:10

Body Sizing 2

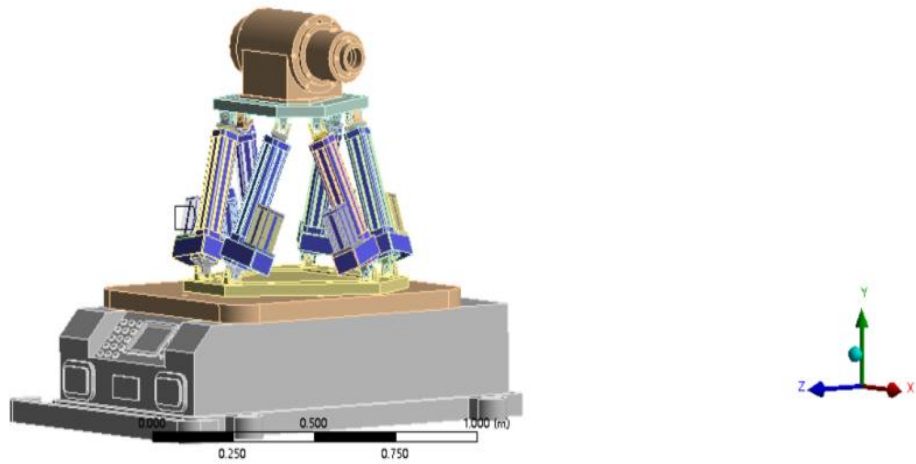

Figure 8 Grid division of parallel robots

After the grid division is completed, fixed constraints are added to the car, so that the mobile robot is not a free mode, and only the first 6 modes of the model are analyzed, and then the natural frequencies of the first 6 orders are calculated. Because the first 6 orders of modes were calculated in this paper, the motion mode and maximum Deformation of the robot at different orders should be obtained, so Solution >Insert >Deformation >Total was selected. Six branches were inserted, and then renamed to distinguish each Total Deformation, as shown in Figure 9. Then, the Mode of the renamed branch was changed to the corresponding number, and the corresponding order was shown in Figure 10.

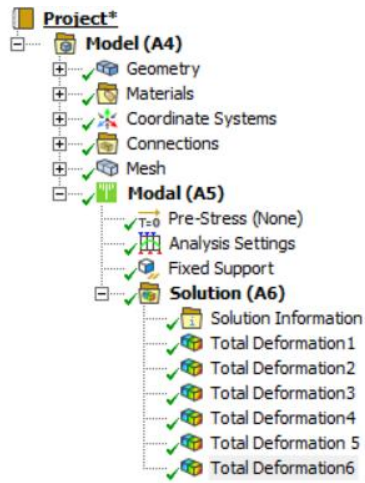

Figure 9 Adding Total Deformation

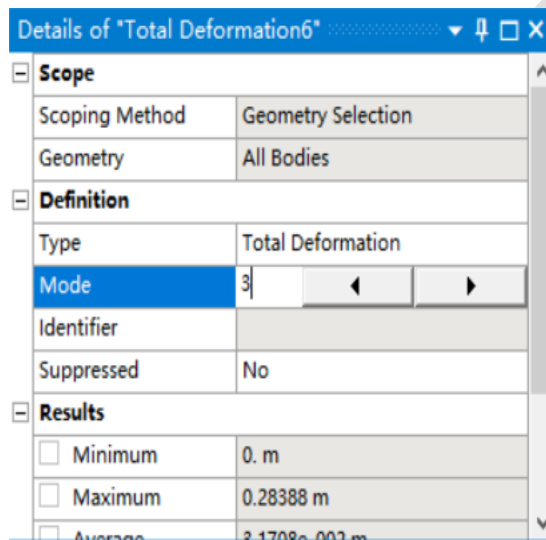
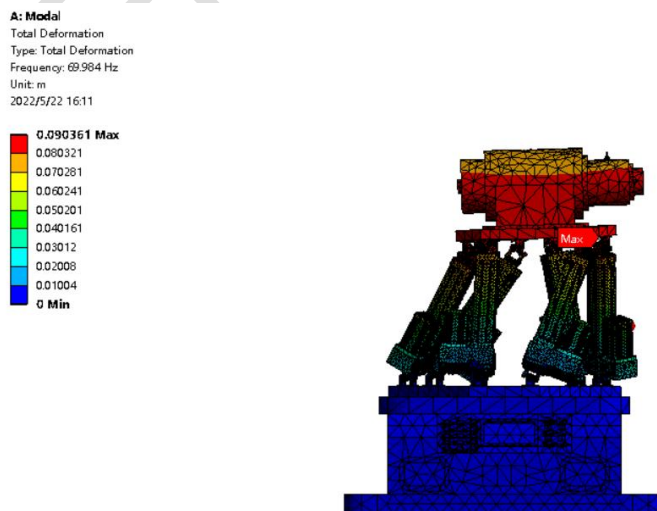

Figure 10 Mode change

Figure 11 shows the cloud image of the mode mode corresponding to each order.



first-order mode

A: Modal
Total Deformation 2
Type: Total Deformation
Frequency: 70.241 Hz
Unit: m
2022/5/22 15:52

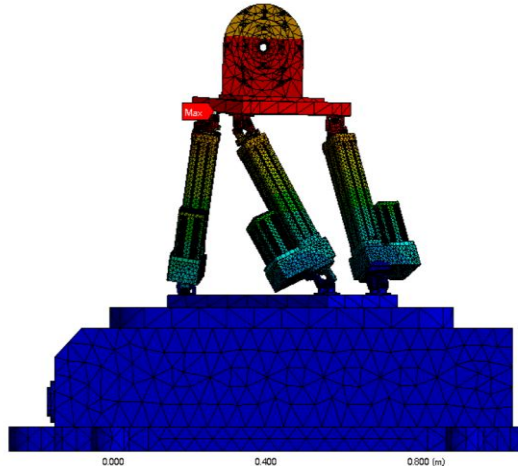
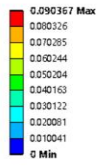

Second order mode

A: Modal
Total Deformation 3
Type: Total Deformation
Frequency: 118.69 Hz
Unit: m
2022/5/22 15:54

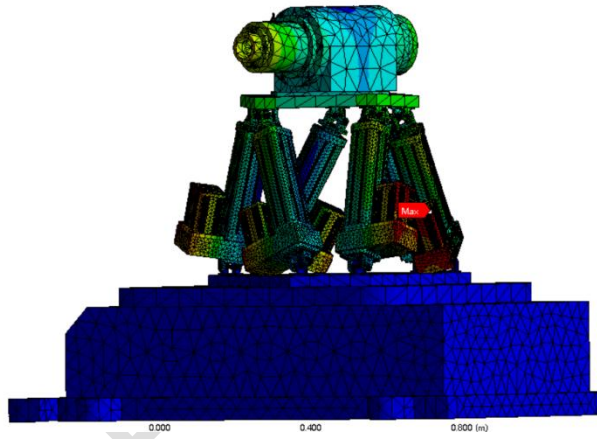
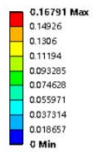

Third order mode

A: Modal
Total Deformation 5
Type: Total Deformation
Frequency: 1349 Hz
Unit: m
2022/5/22 15:56

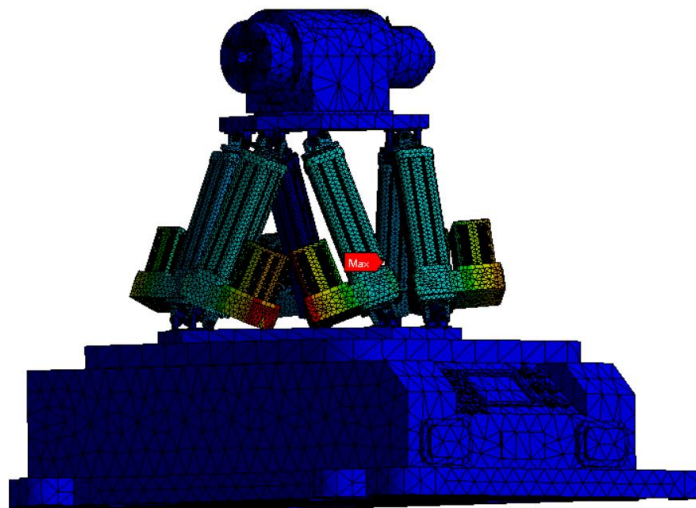
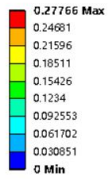

Fourth order mode

A: Modal
 Total Deformation 5
 Type: Total Deformation
 Frequency: 134.9 Hz
 Unit: m
 2022/5/22 15:56

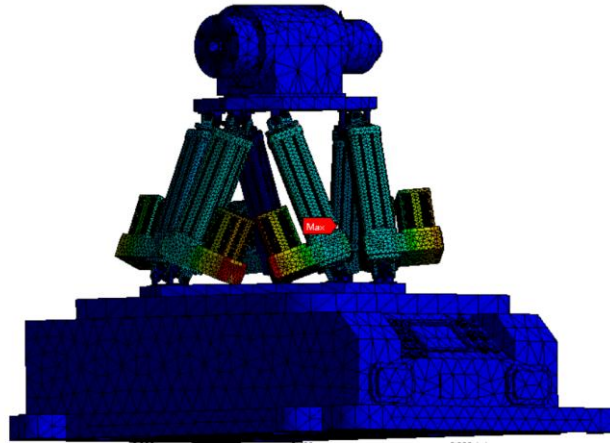
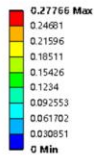

Fifth order mode

A: Modal
 Total Deformation 6
 Type: Total Deformation
 Frequency: 135.01 Hz
 Unit: m
 2022/5/22 15:58

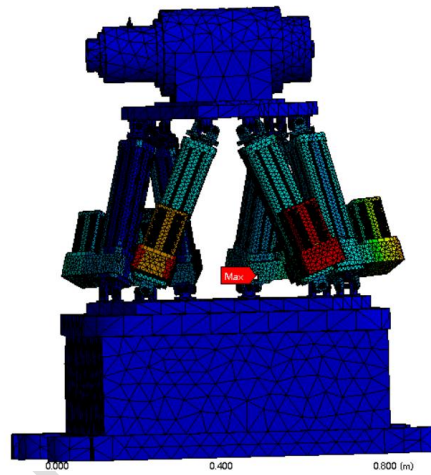
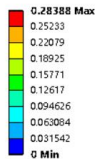

Sixth order mode

Figure 11 Cloud image of mode shape

As shown in Figure 11, the first 6 orders of natural frequencies of the mobile robot have a small variation range, mainly ranging from 69 to 136Hz. The first two or more orders of the platform are translational in the plane XZ parallel to the global coordinate system, and the motorized spindle has the largest deformation, corresponding natural frequencies are 69.984Hz and 70.241Hz respectively. The maximum shape variables were 0.0903mm and 0.0904mm. The third stage is that the electric cylinder drives the robot to rotate around the Y-axis, and the shape variable of the motor is the largest, corresponding natural frequency is 118.69Hz, and the largest shape variable is 0.1679mm. The fourth to fifth order mobile robot's largest shape variable occurs on the electric cylinder, and the fourth order vibration mode is that five of the six electric cylinders rotate. Corresponding natural frequency is 134.82Hz, the fifth order vibration mode is that the first three of the six electric cylinders rotate clockwise and the other three rotate counterclockwise, corresponding natural frequency is 134.9Hz, and the largest variable is 0.383mm and 0.3776mm, respectively. The sixth order is that the last three of the six electric cylinders rotate clockwise and the other three rotate counterclockwise, corresponding to a natural frequency of 135.01Hz. The maximum shape variable occurs at the motor, and the maximum shape variable is 0.2838mm.

5. CONCLUSION

This paper introduces the research process and development status of mobile multi-robot cooperative machining at home and abroad. A 6-DOF parallel robot similar to F200iB robot of Fanuc is used as the main body to build a mobile robot.

Then Adams software was used to add motion pairs to the imported model, and the two sets of data graphs were compared to verify the correctness of the mathematical model, and then the dynamic simulation and modal analysis were carried out. The main research contents are as follows:

(1) The structure of the mobile robot is designed according to the F200iB robot. This paper designs a multi-robot processing platform. I choose two robots to process symmetrically so as to unify the force of the workpiece. In this paper, a 3D model of movable multi-robot machining platform is established by using modeling software.

(2) Dynamic simulation and modal analysis of the mobile robot. The dynamic simulation of circular trajectory of mobile robot tool is carried out by adding force drive in Adams. Then the Solidworks file after Boolean operation is imported into ANSYS Workbench, and the modal analysis of the structure is carried out by this program, and the vibration mode and natural vibration frequency of each structure are obtained.

REFERENCES

1. Zhang Yang, GAO Minghui, ZHOU Wanyong. Research on Cooperative Control Technology of Industrial Robot in Automatic Drilling and riveting System [J]. Aeronautical Manufacturing Technology, 2013, 44(20): 87-90.
2. Zhang Tie, Ouyang Fan. Kinematic analysis and path planning of coordinated following Motion of two Robots [J]. Journal of Shanghai Jiao Tong University, 2013, 47(8): 1251-1256.
3. Meng Wei, Hong Bing-Yong, HAN Xue-Dong. A collaborative control method for multiple Robots [J]. Robot,2004, (01) :58-62.
4. Ye Renping, Zhang Dehuai. Research on Joint simulation of robot arm motion Control based on Adams and Matlab [J]. Modern Manufacturing Engineering,2017,(06):56-61+68.
5. Li Bincheng, Yang Dan, GU Jinfeng. Kinematics Simulation of 6-DOF Parallel Kinematic Machine Tool based on Matlab and Adams [J]. Composite Machine Tool and Automatic Processing Technology, 2009, (11) : 28-31.
6. Li Zhihu. Structural Optimization and Modal Analysis of Mining manipulator Based on ANSYS Workbench [J]. Construction Machinery, 2019,51(01):49-52+9.
7. Yang Jizhi, Lin Xiaoqing, Le Yi et al. Research on Modeling and Simulation of Inspection Milling System by Mobile Robot [J]. Machine Design & Manufacture,2020,(07):170-173.
8. GuoXuwei, Wang Zhixing. Kinematics and Dynamics Simulation of Parallel Machine Tool Based on Adams [J]. China Manufacturing Information Technology,2003,(07):119-122.
9. Chiacchio P, Chiaverini S, Siciliano B. Direct and Inverse Kinematics for Coordinated Motion Tasks of a Two-Manipulator System [J]. Journal ofDynamic Systems Measurement Control, 1996, 118(4):691-697.
10. Andrés M, Raúl S. Coordination of several robots basedon temporal synchronization [J]. Robotics and Computer Integrated Manufacturing,2016(42):73-85.
11. Tavasoli A, Egthesad M, Jafarian H. Twotime scale control and observer design for trajectory tracking of two co operating robot manipulators moving a flexible beam [J].Robotics Autonomous Systems,2009,57(2):212-221.
12. Park Bumjin,KangCheongwoong,ChoiJaesik. Cooperative Multi-Robot Task Allocation with Reinforcement Learning [J].Applied Sciences,2021,1(12):272-273.
13. Biwei Tang, Kui Xiang, Muye Pang. Multi-robot path planning using an improved self-adaptive particle swarm optimization [J].International Journal of Advanced Robotic Systems,2020,5(17).
14. Hernansanz A, Casals A, Amat J. A multirobot cooperation strategy for dexterous task oriented teleoperation [J]. Robotics Autonomous Systems,2015(68):156-172.
15. Panzieri S, PascucciF,Setola R. Multirobotlocalisation using interlaced extendedkalman filter[J]Intelligent Robots and Systems, 2006,66(2):2816-2821.