

# Technical and Enviro-Economic Analyses of a 780 Wp PV System

## ABSTRACT

**Aim:**To determine the technical, economic and environmental performance analysis of an installed PV backup system.

**Study design:**To attain this goal, analysis were performed using a freely available PVSyst 6.7.0 software tool. Economic evaluation was performed using respective present worth of individual component prices. Environmental performance comparison is made between the PV system and diesel generator when each is used as an independent backup system. Input in-situ measured data were determined, measured and keyed into the tool.

**Place and Duration of Study:**The system is installed in an institutional building in a tropical climatic zone with coordinates 0.42 N and 35.03 E. The system was studied for a period of one year where data was collected and recorded for techno-enviroeconomic analysis.

**Methodology:**The system consists of four PV modules rated at 0.78KWp, charge controller and an inverter unit and battery bank, and is utilized as a power backup system to supply electricity whenever power failure occurs, which is frequent and real in Kenya. The techno-enviroeconomic performances analysis of the system were evaluated using the PVSyst software, a freely available design and analytical tool, where input data were measured and recorded at the site.

**Results:**The performance analysis of the system showed that PV array efficiency of 13.24%, FF of 0.68, CF of 21.23%, and PR of 73.63% and generated electrical energy of 1092 kWh/year. The LCOE of PV electricity was 0.059 \$/kWh, while total saving of CO<sub>2</sub> emission in tons of CO<sub>2</sub> was 9.0 tCO<sub>2</sub> with LCE value of 331 gCO<sub>2</sub>/ kWh.

**Conclusion:**Techno- enviroeconomic performance results of the studied PV system show that the system can contribute significantly to the mitigation of CO<sub>2</sub> emission. This work also could be helpful for consumers and policy makers in the choice of renewable based or fossil based backup generation systems

*Keywords: Solar photovoltaic, Techno-enviroeconomic, Performance analysis, PVSyst*

## 1. INTRODUCTION

Energy is an essential resource globally for economic and social development. Availability of reliable and affordable energy sources is beneficial for accelerated growth of the economy and industrialization of a nation as well as improvement of quality of life of her citizens. Demand for electricity have shown gradual rise driven by global growth of population, technology advancement and general economic growth. Several important aspects of energy are currently experiencing a period of transformation. These include energy production (with regards to both fossil fuels and renewable energy sources); transportation and distribution (e.g., electricity and distribution networks); consumption (including demand-side management and energy efficiency); and energy security and access (Kristie et al., 2019). Energy transitions also play a crucial role in climate change mitigation. Electricity, from a practical viewpoint, drives economic productivity and industrial growth and is central to the operation of any modern economy and livelihood. Provision of electricity is now considered as a necessity along with food and water (Hemza et al., 2019). Many countries throughout are increasingly incorporating locally available renewable energy (RE) into their energy supply mix. This trend is informed mainly by the perceived scarcity of fossil fuels and increasing restriction on their use as a result of their adverse effects on climate change.

Among the available REs, solar-generated electricity is expected to proliferate in the future due to declining costs of photovoltaics and its increased penetration into the main grid (Hayat et al., 2019; Kannan and Vakeesan, 2016). In addition, with the depletion of traditional fossil fuels, their disastrous impact on the environment and rising costs, RE sources such as PV energy are rapidly emerging as sustainable and clean sources of power generation. The PV system has the ability to transform solar energy into electricity. The key aspect in PV is the need to store energy during non-sunshine hours which can be achieved using battery storage system or connecting the PV system to the utility system (Astakhov et al., 2020). For optimum performance of any PV system, the important parameters to be considered are performance ratio (PR), energy yield and system loss. The PR is a key indicator for analyzing the efficiency of the PV system and gives the relationship between the actual output of the solar energy and the theoretical output, regardless of different system losses, such as cell mismatch losses, PV module temperature losses, inverter and charge controller efficiency losses, electric cable losses, etc. (Rekhashree and Naganagouda, 2018; Kumar et al., 2021). Recent technological advancements in the PV industry have shown that PV systems can be used to power industrial, commercial and domestic customers either by standalone or grid-connected PV systems (Tamoore et al., 2021).

A technical and economic evaluation was presented by Irfan et al., (2019) for a stand-alone PV system installed in Punjab, Pakistan, showing an LCOE of 0.036 \$/kWh and a mitigation of 617,020 metric tons of CO<sub>2</sub> annually by electrifying 100% rural households with the off-grid solar PV system. A similar research was presented by Omar and Mahmoud, (2018) for a selected number of home systems in Palestine, showing a payback in less than five years for a 5 kW system. Additionally, Allouhi et al., (2016) studied the energy production from two PV technologies in an institutional building in Morocco by evaluating the economic and environmental aspects and comparing them with other PV plants worldwide. The impact of variations in PV module parameters, temperature, the height of solar PV plates from the ground, weather conditions, different geographical locations, and the diffusion of light on the generation of electrical power has been investigated by Ibrahim and Anani, (2017); Ike, (2017); Mafimidiwo and Saha, (2016) and Mohanty and Wittkopf, (2016). A study by Vijay et al., (2018) on performance analysis of a 15 kW standalone solar PV system installed in Vellore District, Tamil, reported energy yield ranging from 6,500–7,000 kWh, PR of 78%, and utilization factor of 6.97%. A study carried out on performance analysis of stand-alone PV system in a health clinic in Nigeria by Ezenugu et al., (2016) reported annual energy yield of 5269 kWh/year, PR of 58.4%, array efficiency of 8.83%, loss of load probability of 7.1%.

A research on greenhouse gas (GHG) mitigation potential and abatement costs in the Brazilian residential sector has been carried out by González-Mahecha et al., (2019). Their findings show that energy efficiency measures in the cooking end-use and solar PV systems would represent together more than 70% of the abatement potential. In addition, the total avoided emissions would be 642 MtCO<sub>2</sub> in Brazil over the period of 2010–2050. In a similar study by Tiwari et al., (2015), environmental and economic analysis of a stand-alone PV system was carried out and their results show that the amount of CO<sub>2</sub> emitted per kWh is approximately 960 g. However, from their findings, this amount rises to 2.0 kg of CO<sub>2</sub> per kWh if transmission losses (40%) and distribution losses (20%) are considered.

The PV performance simulation studies where PVsyst software tools are employed have been reported by many authors. Spea and Khattab, (2019) designed and carried out performance analysis of stand-alone PV systems using PVSyst software for a location in Egypt. They employed PV panels of 450 W and 260 W in their study based on watt-hour demand calculations for comparisons. Their results showed that both PV panels can feed the desired load. The 450 W PV panel is better than 260W PV because of higher value of energy produced per year and occupied a lower area. Kumar et al., (2020) employed PVsyst tool to design and simulate a stand-alone solar PV system in India. Their results showed that the energy required was 1086.24 kWh and the energy available through solar panel was 1143.6 kWh, whereas energy supplied to the user was 1068.12 kWh with average PR for the year as 72.8%. In addition, Sifat et al, (2015) designed a 2 kW Stand-alone PV System with backup in Bangladesh Using PVsyst, Homer and SolarMAT software tools. The PVsyst showed mismatch with practical data to a small extent and a good choice for economic analysis while output results generated by SolarMAT has a great similarity with practical data.

Kenya is endowed with high solar irradiance at an average of 5 kWh/m<sup>2</sup>/day throughout the year, hence huge potential which can be exploited to generate green electricity for every household across the country (Oloo et al., 2015; Kiplagat et al, 2011; Kariuki and Sato, 2018). Therefore, Kenya is attractive for PV power installations as a result of its excellent solar resource throughout the year. The PV is projected to grow at 15% annually in Kenya, but this is still marginal compared to expected potentials, and in many case developments is on off-grid systems (ERC, 2019). The slow pace is attributed to low government incentives, policies that do not directly support prosumer utilization of PV power and low research funding. In this regard, research work on operation and performance of PV systems under varying outdoor conditions is important to promote PV power. Techno- enviroeconomic analysis of existing PV systems is of great importance to the consumers and policy makers in promoting and distribution of PV technologies. This work the analysis is performed using a PVSyst (PVsyst Program, 2019) software tool that is freely available.

## 2. MATERIAL AND METHODS

### 2.1. PV system setup

This study was carried out at an institutional building in a tropical climatic zone with coordinates 0.42 N and 35.03 E hence have abundance of solar irradiation. The PV system was installed in 2016 and is operated as a stand-alone power backup to the grid. Batteries are employed for storing the generated electricity. Electrical load profile consists of total power rating of approximately 2.076 kWh/day excluding losses which result from the inverter, charge controller, battery and connections through the switch over control system. The PV modules are made of solar cells of the Polycrystalline type which make up an array where each is rated 195 W. Thus, the tilt angle and orientation (azimuthal) of the PV array are dictated by the pitch angle and the orientation of the roof building. The roof has a pitch angle of 15° and oriented in the NE-SW direction, which are respectively the tilt and azimuthal of the PV array. There is an air gap of ~18 cm between the PV array and the corrugated iron sheet for air flow. Table 1 presents the technical specifications of each of the module used in the studied system.

**Table 1: Specification of PV module**

Parameter	A (m <sup>2</sup> )	V <sub>oc</sub> (V)	I <sub>sc</sub> (A)	P <sub>o</sub> (W)	NOCT (°C)	V <sub>mp</sub> (V)	I <sub>mp</sub> (A)	η <sub>ref</sub> (%)	β (°C <sup>-1</sup> )
Value	0.4	44.5	5.70	195	45±2	36	5.56	15.6	0.0041

A schematic for the studied PV system is shown in Figure 1 where the components and connections of the PV system are given. As demonstrated, the basic components of the system are the PV modules, charge controller, battery bank, an inverter, loads (appliances), and the switch over control system.

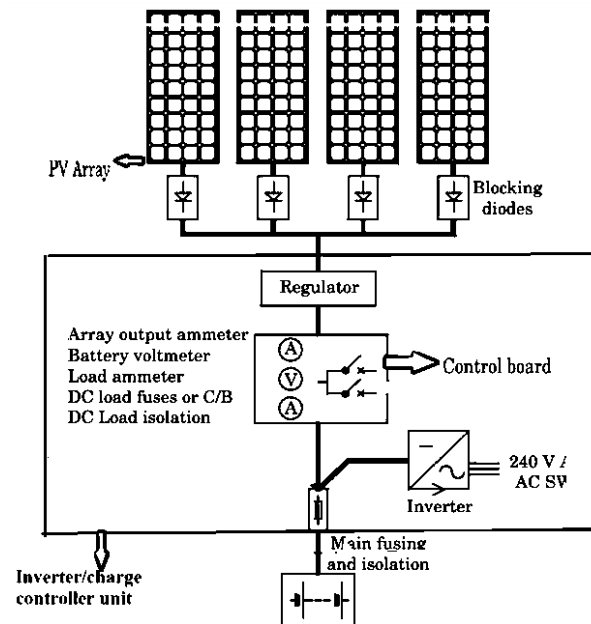
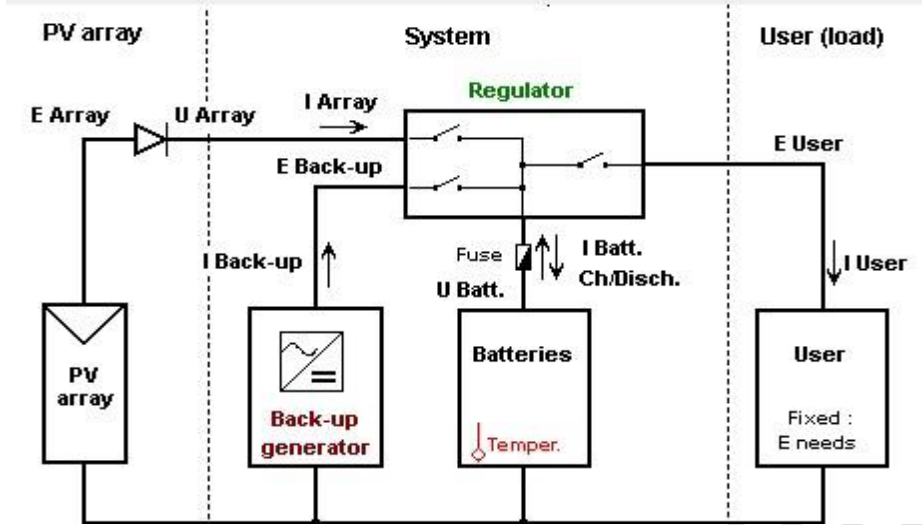

**Fig 1: Schematic diagram of the studied PV backup system**

## 2.2. PVSyst tool

Techno-enviroeconomic analysis of installed PV backup system was performed using a freely available PVSyst 6.7.0 software tool (Belmahdi and Bouardi, 2020; Satish *et al.*, 2020; Shukla *et al.*, 2016). Operating system that the tool runs on must be windows 7 and above (32-bit or 64-bit). The tool is used for optimization of a PV system under outdoor conditions for a given location and in determining their technical, economic and environmental performance parameters (Odeh and Nguyen, 2021). Economic evaluation was performed using respective present worth of individual component prices. In addition, a performance comparison is subsequently made between the PV system and diesel generator when each is used as an independent backup system. Figure 2 shows a standard diagram of the PV system together with a diesel generator used as backup systems independly.

The tool has wide options and built-in features that enable one to input in-situ measured data or use the already existing PVSyst databases (built in Meteo database) (Meteonorm, 2010). The operating conditions dataset used for the PV performance analysis in this paper are the site determined data that were keyed in into the tool. This include site coordinates and time zone details (Kapur, 2015; Vasanthkumar and Naganagouda, 2017). In addition, outdoor data keyed in include measured solar irradiance, wind speed, ambient temperature and I-V data. Furthermore, system characteristics included the PV system type (stand-alone), tilt angle, system size, module battery and inverter type are defined. Also the facility's load profile details are keyed in (Rekhashree *et al.*, 2018). Simulation is then run to generate the final result file. The simulation output file is presented in form of tables and graphs. Output results can be obtained on weekly, daily, or hourly basis depending on the user's needs in form of project details.



**Fig 2:Schematic backup system layout in PVSyst software.**

### 2.3. Performance parameters

Recommended technical parameters to qualify performance of a PV system include array efficiency ( $\eta_{array}$ ), the fill factor (FF), yield ratios (reference yield,  $Y_r$ , final yield,  $Y_f$  and system losses,  $L_s$ ), performance ratio (PR), and capacity factor (CF). In addition, economic and environmental parameters include; levelized cost of energy (LCOE) and amount of CO<sub>2</sub> mitigated ( $\Phi_{CO_2}$ ). These parameters are given in Table 2. In PV systems, there is no fuel cost and only the operations and maintenance (O&M) are considered and factored in as a fraction of the investment made. Here, the PV module lifetime of 25 years has been taken into account and both the initial and O&M costs are included as fixed costs.

**Table 2: Performance parameters**

Parameter	Equation	Source
Array efficiency	$\eta_{array} = \frac{P_{max}}{A \times G_t} \times 100\%$	(Ayompea, 2011; Rakhi and Tiwari, 2012)
Fill factor	$FF = \frac{V_{max} \times I_{max}}{V_{oc} I_{sc}}$	(Al-Aboosi, 2020)
Output energy	$E_{PV} = \int_{t=1}^n \frac{1}{6000} G_t A \eta_{array}$	(Al-Aboosi, 2020; Žnidarec <i>et al.</i> , 2019; Ayompea, 2011)
Reference yield	$Y_r = \frac{G_t}{G_o}$	(Satsangi <i>et al.</i> , 2018)

Final yield	$Y_f = \frac{E_{PV}}{P_o}$	(Satsangi <i>et al.</i> , 2018)
System losses	$L_s = Y_r - Y_f$	(Ayompea, 2011; Satsangi <i>et al.</i> , 2018)
Performance ratio	$PR = \frac{Y_f}{Y_r}$	(Almarshoud, 2017)
Capacity factor	$CF = \frac{P_o}{P_{max}} \times 100$	(Ayompea, 2011; Žnidarec <i>et al.</i> , 2019)
Live cycle cost	$LCC = \sum_{r=1}^6 C_r$	(Gulaliyev <i>et al.</i> , 2020)
Levelized cost of energy	$LCE = \sum_{i=0}^n AEP \times (1 - f_{PV})^i / (1 - r)^r$	(Muslim <i>et al.</i> , 2018)
Amount of CO <sub>2</sub> mitigated	$\Phi_{CO_2} = \frac{\Psi_{CO_2} \times E_{overall}}{1000}$	(Tiwari <i>et al.</i> , 2015)

### 3. RESULT AND DISCUSSION

#### 3.1. Normalized production (per installed kW)

Figure 3 shows the normalized energy productions are evaluated from PVsyst simulation tool. From the results, it is observed that collection loss is 0.61 kWh/kWp/day, system and battery charging loss is 0.62 kWh/kWp/day, and energy supplied to the user is 3.44 kWh/kWp/day.

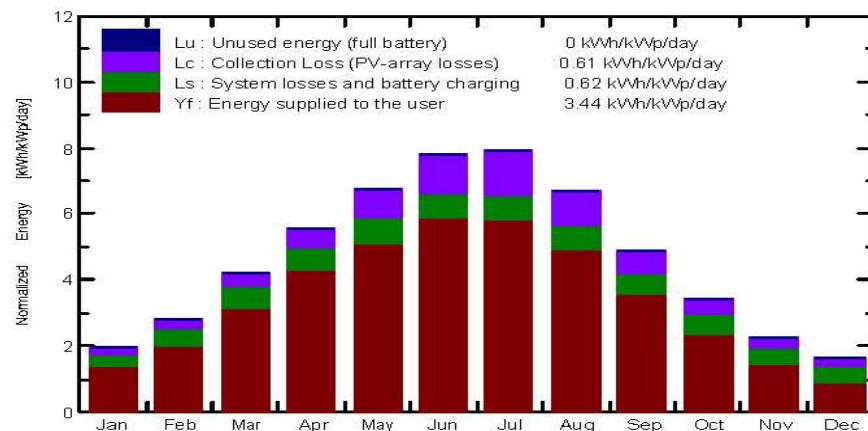

Fig 3. PVsyst monthly result report of normalized energy

### 3.2. Performance ratio and solar fraction

Figure 4 shows monthly variations of PR and solar fraction during the period of study. The values of PR varied from 57.5.9% in the month of December to 76.4% in the month of April with an average annual value of 73.6%. This means that ~25% of the incident solar energy is not converted into usable energy which indicates a possible fault in components, conduction losses and thermal losses. These values are within the agreed range in literature (Rekhashreeet *al.*, 2018; Ayompea, 2011).

Solar fraction is given as a ratio of total energy produced by the PV system to the load demand of the facility. The annual solar fraction is 21.23%. Fixed-tilt PV systems (the case for the studied system) are expected to have solar fraction values between 20.8% and 26.0% in high solar radiation regions, hence the obtained results compare well with the reported range, hence the site has very good solar energy potential sufficient for exploitation for electricity generation.

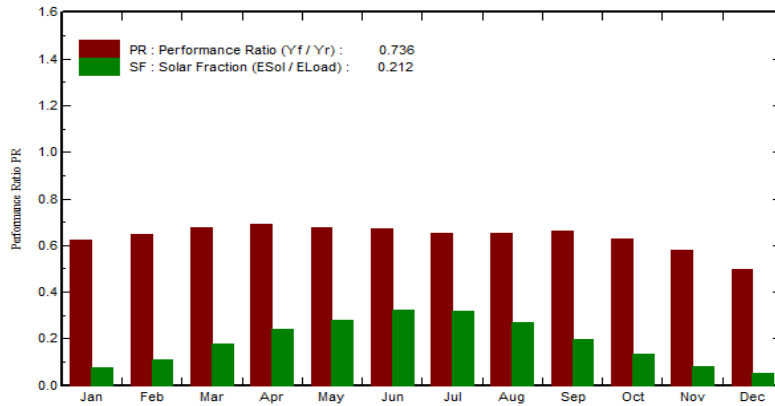

Fig 4. PVsyst monthly result report of performance ratio and solar fraction.

Figure 5 show the PV system loss diagram over the period of study. The PV Power system losses play an important role both during initial PV system designing and monitoring stages. To be more specific, expected losses are always considered during PV system sizing and in determining amount of power that is generated over the PV module lifetime. From the figure, global horizontal irradiance (GHI) at the site is 1982 kWh/m<sup>2</sup>, and the efficient irradiation which falls in day time on the collector plane is almost 1621 kWh/m<sup>2</sup> giving a loss value of about -13.9%. It is further observed that the generated energy from the PV array is affected by several factors such as the thermal parameters, module quality losses, module temperature, AC and DC wiring losses etc. These factors can further be divided into main losses which are the system losses, array losses, and total losses as presented. In addition, array losses of 0.61 kWh/kW/day and system losses of 0.64 kWh/kW/day were obtained respectively. Loss of energy due to variations in temperature compared to standard test conditions (STC) is observed to be 6.3%.

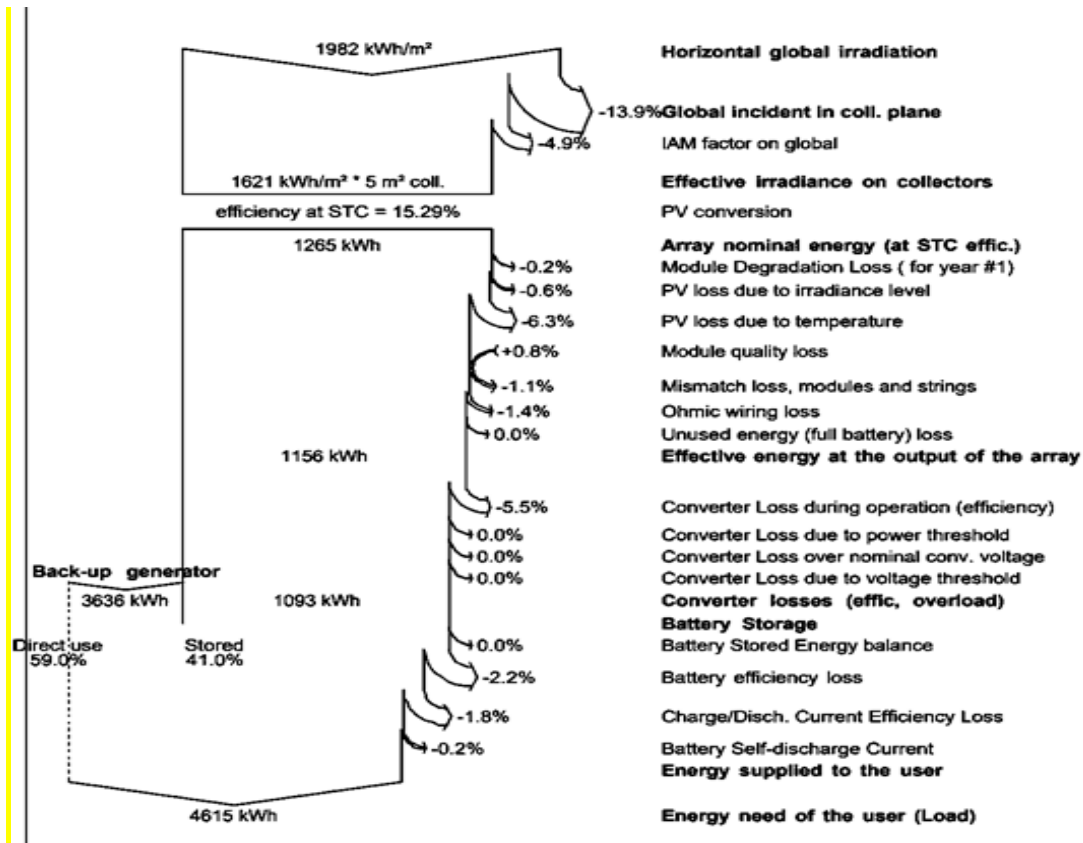

Fig 5. PVsyst Loss Diagram over the whole year

### 3.3. Balances and main results

Energy production performance indicators are given in Table 3 as monthly average values.

Table 3: Monthly average values of energy performance parameters.

Month	$E_{pc}$ (kWh)	$Y_r$ (kWh/kW)	$Y_A$ (kWh/kWp)	$L_A$ (kWh/kW)	FF	Array Efficiency (%)
Jan	285.50	5.99	3.60	0.76	0.68	14.92
Feb	296.51	5.95	3.26	0.85	0.71	14.56
Mar	305.72	5.69	4.15	0.72	0.75	14.68
Apr	300.51	5.72	4.15	0.65	0.65	13.35
May	345.22	5.12	4.22	0.46	0.68	12.54
Jun	325.62	4.98	5.21	0.49	0.67	12.85
Jul	318.60	4.95	5.38	0.38	0.65	12.45

Aug	302.40	5.52	5.02	0.40	0.64	12.03
Sep	336.34	5.68	4.10	0.66	0.69	12.17
Oct	324.50	5.62	3.94	0.72	0.66	12.28
Nov	309.10	5.52	3.64	0.61	0.69	12.56
Dec	296.46	5.84	3.51	0.69	0.67	13.95
Yearly	312.20	5.55	4.18	0.61	0.68	13.19

The results in Table 3 show that the  $E_{DC}$  varied from 285.50 kWh in the month of January to 345.22 kWh in the month of May with an annual average value of 312.19 kWh hence a daily value of 10.41 kWh. The facility's load profile demand is 2.076 kWh and compared with daily value of 10.41 kWh shows that power produced is sufficient to satisfy the facility and system can be used not only as a backup system but also to alleviate part of the grid demand for the facility. The  $Y_A$  values varied from 3.26 kWh/kWp to 5.38 kWh/kWp with an annual average of 4.182 kWh/kWp. From these results, the number of hours per year at which the system effectively operates at its rated power is ~4 hours. The values of  $Y_r$  varied between 4.95 kWh/kW to 5.99 kWh/kW with annual average value of 5.548 kWh/kW. Thus, it is relatively close and agrees with similar studies carried out in Kenya that gave a value of 5.5 kWh/kW (Oloo *et al.*, 2015; Kiplagat *et al.*, 2011). In other words, these results imply that the daily site peak sun hours were slightly over 5 hours and can be improved with optimal orientation of the PV array.

Annual average array efficiency value is 13.19% and the FF value is 0.68. The array efficiency results are lower than the STC value, and are expected for outdoor test conditions. In addition, the array efficiency fluctuates with the season of the year because of changing operating conditions. On the other hand, the value of the FF is almost one-half of the expected value of one (1), meaning that the plane of array (POA) solar radiation is not optimized. The possible reason for the low values of FF is that the studied PV system is not installed optimally with regard to tilt angle (should be equal to latitude of the site) and azimuthal angle or orientation.

### 3.4. Economic results

Figure 6 shows the economic input information and output results of the PV backup system compared to that of a diesel generator. The investment and energy cost aspects of both the PV backup system and the diesel generator are determined. As reflected in the figure, the PV system LCOE of 0.059 \$/kWh which is significantly lower relative to the current grid value and that of the diesel generator when used as a backup system were obtained.

<b>Investment</b>			
PV modules (Pnom = 195 Wp)	4 units	215 US\$/unit	858 US\$
Supports/Integration		0 US\$/module	0 US\$
Batteries (26 V / 3 Ah)	4 units	450 US\$/unit	1800 US\$
controller			210 US\$
Settings, wiring, .			235 US\$
Substitution underworth			0 US\$
<b>Gross investment</b> (without taxes)			<b>3103 US\$</b>
<b>Financing</b>			
Gross investment (without taxes)			3103 US\$
Taxes on investment (VAT)	Rate 15.0 %		465 US\$
Gross investment (including VAT)			3568 US\$
Subsidies			0 US\$
<b>Net investment (all taxes included)</b>			<b>3568 US\$</b>
Annuities	(Loan 5.0 % over 20 years)		286 US\$/year
Maintenance			17 US\$/year
insurance, annual taxes			0 US\$/year
Provision for battery replacement	(lifetime 6.9 years)		20 US\$/year
Fuel for Back-Up generator	(Back-Up energy 3636 kWh/year)		2410 US\$/year
<b>Total yearly cost</b>			<b>2734 US\$/year</b>
<b>Energy cost</b>			
Used solar energy			4615 kWh / year
Excess energy (battery full)			0.0 kWh / year
Used energy cost			0.059 US\$/ kWh

**Fig 6: Economic input data and output results**

### 3.5. Environmental results

Figure 7 shows the environmental CO<sub>2</sub> balance diagram. It is seen that total amount of carbon dioxide emissions that are directly saved is 9.0 tCO<sub>2</sub>/year. The LCE represent the emissions of CO<sub>2</sub> associated with the PV system for which it includes its total life cycle from production to disposal inclusive of long distance ship cargo and large truck transportation. LCE value of 331 gCO<sub>2</sub>/kWh is obtained.

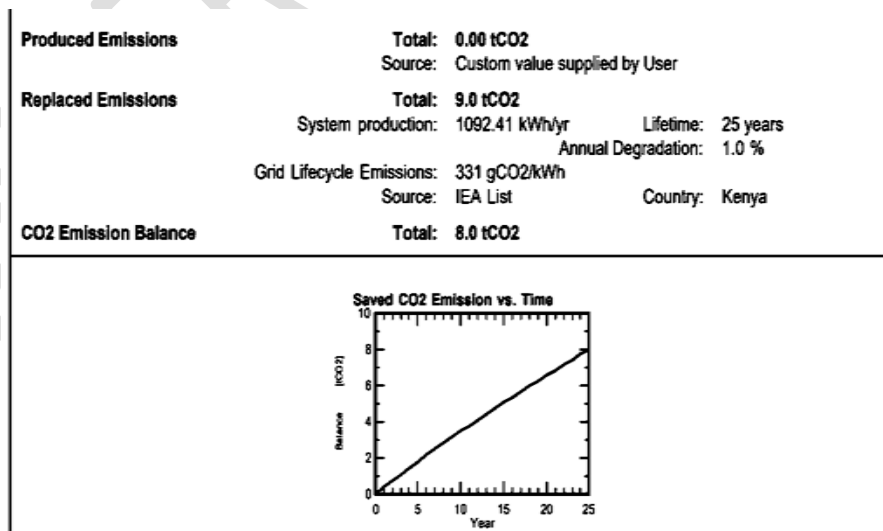

**Fig 7: CO<sub>2</sub> balance**

#### 4. CONCLUSION

A detailed study of a 0.78 kWp off-grid solar PV system installed as a backup system to the grid is presented in this work where its techno- enviroeconomic performance is evaluated using a PVsyst software simulation tool. Performance results obtained gives a PV array efficiency of 13.2%, FF of 0.68, solar fraction of 21.23%, PR of 73.63% and generated electrical energy of 1092 kWh/year. Economic results show that LCOE value is 0.059 \$/kWh which indicates that the cost of solar power is far much below the cost of electricity from the grid and a payback period of 4.86 years. Environmental values show that the total amount of CO<sub>2</sub> emissions that are directly saved is 9.0 tCO<sub>2</sub> equivalent to 0.75tCO<sub>2</sub>/ month with LCE value of 331 gCO<sub>2</sub>/ kWh. It is inferred that the installed PV system is reliable as a backup system and can produce the required demand energy. In addition, the paper could be helpful for consumers and policy makers in the choice of renewable based or fossil based backup generation systems.

#### Disclaimer

This paper is an extended version of a Thesis document of the same author.

The Thesis document is available in this link:  
<http://erepository.uoeld.ac.ke/bitstream/handle/123456789/1743/WILKINS%20%20CHERUIYOT.pdf?isAllowed=y&sequence=1>

[As per journal policy, preprint /repository article can be published as a journal article, provided it is not published in any other journal]

#### REFERENCES

1. Al-Aboosi, F.Y. (2020). Models and hierarchical methodologies for evaluating solar energy availability under different sky conditions toward enhancing concentrating solar collectors use: Texas as a case study. *Int. J. Energy Environ. Eng*; 11, 177–205.
2. Allouhi, A.; Saadani, R.; Kousksou, T.; Saidur, R.; Jamil, A.; Rahmoune, M. (2016). Grid-connected PV systems installed on institutional buildings: Technology comparison, energy analysis and economic performance. *Energy Build*, 130, 188–201.
3. Almarshoud, A. (2017). Technical and Economic Performance of 1MW Grid-connected PV system in Saudi Arabia. *Int. J. Eng. Res. Appl*; 7, 9–17.
4. Ayompea, L., Duffya, A., McCormackb, S. and Conlonc, M. (2011). Measured Performance of a 1.72 kW Rooftop Grid Connected Photovoltaic System in Ireland. *Energy Conversion and Management*, 52, 816-825.
5. Astakhov, O.; Merdzhanova, T.; Kin, L.C. and Rau, U. (2020). From room to roof: How feasible is direct coupling of solar-battery power unit under variable irradiance? *Sol. Energy*, 206, 732–740.
6. Belmahdi, B. and Bouardi, A.E. (2020). Solar Potential Assessment Using PVsyst Software in the Northern Zone of Morocco. *Procedia Manuf*; 46, 738–745.
7. Ezenugu. I. A., Umoren M. A., and Okpura. I. (2016). Performance Analysis of Stand-Alone Photovoltaic (SAPV) System for Category I Health Clinic in Orlu, Imo State, Nigeria. *Mathematical and Software Engineering*: 2(1): 35-47.
8. González-Mahecha. R.E., Lucena. A.F.P. and R. Garaffa. (2019). Greenhouse gas mitigation potential and abatement costs in the Brazilian residential sector, *Energy & Buildings*.184; 19–33.

9. Gulaliyev, M.G.; Mustafayev, E.R. and Mehdiyeva, G.Y. (2020). Assessment of Solar Energy Potential and Its Ecological-Economic Efficiency: Azerbaijan Case. *Sustainability*, 12, 11-16.
10. Hayat, M.B.; Ali, D.; Monyake, K.C.; Alagha, L.; Ahmed, N. Solar energy. (2019). A look into power generation, challenges, and a solar-powered future. *Int. J. Energy Res*, 43, 1049–1067.
11. Hemza, A., Abdeslam, H., Rachid, C and Aoun, N. (2019). Simplified methods for evaluating the degradation of photovoltaic module and modelling considering partial shading, *Measurement*, 138, 217-224, ISSN 0263-2241.
12. Ibrahim, H. and Anani, N. (2017). Variations of PV module parameters with irradiance and temperature. *Energy Procedia*, 134, 276–285.
13. Ike, C.U. (2017). The Effect of Temperature on the Performance of A Photovoltaic Solar System in Eastern Nigeria. *Int. J. Eng. Sci*, 3, 10–14.
14. Irfan, M., Zhao, Z., Ahmad, M., and Rehman, A., (2019). A Techno-Economic Analysis of Off-Grid Solar PV System: A Case Study for Punjab Province in Pakistan. *Processes*; 7, 708.
15. Kannan, N.;Vakeesan, D. (2016). Solar energy for future world: A review. *Renew. Sust. Energy Rev*; 62, 1092–1105.
16. Kapur, A.S. (2015). *A Practical Guide for Total Engineering of MW Capacity Solar PV Power Project*, 1st ed.; White Falcon Self-Publishing Platform: Chandigarh, India.
17. Kariuki, B. W. and Sato, T. (2018). Inter-annual and spatial variability of solar radiation energy potential in Kenya using Meteosat satellite. *Renewable energy*, 116, 88-96.
18. Kiplagat, J. K., Wang, R. Z., and Li, T. X. (2011). Renewable energy in Kenya: Resource potential and status of exploitation. *Renewable and Sustainable Energy Reviews*, 15(6), 2960–2973.
19. Kristie L Ebi, Luisa F. Cabeza; Jin Chen. (2019). We believe in a brighter future. *Introducing Global Transitions—Connecting Forward-Thinking. Global Transitions*; 1. 1-2. 10.1016/j.glt.2019.03.001.
20. Kumar, R., Rajoria, C.S., Sharma A. and Suhag, S. (2020). Design and simulation of standalone solar PV system using PVsyst Software: A case study, *Materials Today, Proceedings*, 46 (4).
21. Kumar, R.; Rajoria, C.S.; Sharma, A. and Suhag, S. (2021). Design and simulation of standalone solar PV system using PVsyst Software: A case study. *Mater. Today Proc.* 46, 5322–5328.
22. Mafimidiwo, O.A.; Saha, A.K. (2016). Incorporating a three dimensional photovoltaic structure for optimum solar power generation—the effect of height. *J. Energy S. Afr.*, 27, 22–29.
23. *Meteonorm handbook*, Version 6.12, Part II: Theory. Meteotest, 2010
24. Mohanty, L.; Wittkopf, S.K. (2016). Effect of diffusion of light on thin-film photovoltaic laminates. *Results Phys*, 6, 61–66.
25. Muslim, Hasan Noaman, AfaneenAlkhazraji, and Mohammed Ahmed Salih. (2018). Feasibility study of using 2kWp residential PV system comparing with 2.5 kVA gasoline generator (Case study: Baghdad city). *International Journal of Energy and Environment*; 9(1): 57-62.
26. Odeh, S. and Nguyen, T.H. (2021). Assessment Method to Identify the Potential of Rooftop PV Systems in the Residential Districts. *Energies*; 14, 42-48.
27. Omar, M.A.; Mahmoud, M.M. (2018). Grid connected PV-home systems in Palestine: A review on technical performance, effects and economic feasibility. *Renew. Sustain. Energy Rev*, 82, 2490–2497.
28. Oloo, F., Olang, L. and Strobl, J. (2015). Spatial Modelling of Solar Energy Potential in Kenya. *Int. J. Sustain. Energy Plan. Manag.* 6: 17–30.

29. PVSyst Program. PV Syst User Manual. (2019). Available online: <http://files.pvsyst.com/help/> (accessed on 7 May 2022).
30. Rakhi S. and Tiwari G.N. (2012). Technical performance evaluation of stand-alone photovoltaic array for outdoor field conditions of New Delhi. *Applied Energy*, 92; 644- 652.
31. Rekhashree, D.J. and Naganagouda, H. (2018). Study on Design and Performance Analysis of Solar PV Rooftop Standalone and On Grid System Using PVSYST. *Int. Res. J. Eng. Technol. (IRJET)*, 5, 41–48.
32. Rehashree A, Rajashekar J.S and Naganagouda H. (2018). Study on Design and Performance Analysis of Solar PV Rooftop Standalone and On Grid System Using PVSyst” *IRJET*. 5 (7).
33. Satish, M.; Santhosh, S.; Yadav, A. (2020). Simulation of a Dubai Based 200 KW Power Plant Using PVSyst Software. In *Proceedings of the 2020 7th International Conference on Signal Processing and Integrated Networks (SPIN)*, Noida, India, 27–28 February 2020; 824–827.
34. Satsangi P., Das B., Babu S. and Saxena A.K. (2018). Performance analysis of grid interactive solar photovoltaic plant in India. *Energy Sustain. Dev*; 47, 9-16.
35. Shukla, A.K., Sudhakar, K and Baredar, P. (2016). Exergetic assessment of BIPV module using parametric and photonic energy methods, A review. *Energy Build.* 119, 62–73.
36. Sifat, M., Shoaib, M.A., Tanzil, H.C., Anikur, R.S. and Rahman, A. (2015). Designing of a 2 kW stand-alone PV system in Bangladesh using PVSyst, Homer and SolarMAT, Conference Paper, DOI: 10.1109/ICGET.2015.7315090.
37. Spea. S.R. and Khattab. H.A. (2019). Design sizing and performance analysis of stand-alone PV system using PVSyst software for a location in Egypt. In: *Proc. of 21st Int. Middle East Power Syst. Conf. MEPCON 2019 – Proc*, 9: 927–932.
38. Tamoor, M.; Tahir, M.A.B. and Zaka, M.A. (2021). Photovoltaic Integrated Distributed Energy Generation System for Sustainable Energy Development Considering Reliability Indices and Levelized Cost of Energy. *Int. J. Adv. Trends Comput. Sci. Eng.* 10, 2540–2549.
39. Tiwari. G. N., Yadav. J. K., Singh. D. B., Al-Helal. I. M and Abdel-Ghany. A. M. (2015). Exergoeconomic and enviroeconomic analyses of partially covered photovoltaic flat plate collector active solar distillation system, *Desalination*, 367, 186–196.
40. Vasanthkumar, D.S.; Naganagouda, D.H. (2017). Design and Development of 5MW Solar PV Grid Connected Power Plant Using PVSyst. *Int. Res. J. Eng. Technol*, 4, 778–785.
41. Vijay, M. D., Singh, B. and Bhuvanewari, G. (2018). Standalone and grid connected operations of a SynRG based WECS with BESS. In *2018 IEEMA Engineer Infinite Conference (eTechNxt)* (pp. 1-6). IEEE.
42. Žnidarec, M.; Šljivac, D.; Došen, D. and Dumnin, B. (2019). Performance Assessment of Mono and Poly Crystalline Silicon Photovoltaic Arrays under Pannonian Climate Conditions. In *Proceedings of the IEEE EUROCON 2019–18th International Conference on Smart Technologies*, Novi Sad, Serbia, 1–4 July 2019; IEEE: Piscataway, NJ, USA, 2019; 1–6.

## DEFINITIONS, ACRONYMS, ABBREVIATIONS

Definition of term			
$I_{mp}$	Nominal current (A)	PR	Performance ratio (%)
$V_{oc}$	Open circuit voltage (V)	$V_{max}$	Maximum voltage (V)

$I_{SC}$	Short-Circuit Current (A)	$E_{Dc}$	DC output energy (kWh)
$\eta_{ref}$	Reference Module efficiency (%)	$Y_A$	Array yield (kWh/kW)
$A$	Module area (m <sup>2</sup> )	$Y_r$	Reference yield (kWh/kW)
$G_t$	Measured solar irradiance (W/m <sup>2</sup> )	$Y_f$	Final yield (kWh/kW)
$P_o$	Module rated power (W)	$\eta_{array}$	Array efficiency
$\beta$	Cell temperature parameter (K <sup>-1</sup> )	$L_A$	Array capture loss (kWh/kW)
$P_{max}$	Maximum power(W)	$I_{max}$	Maximum current (A)
FF	Fill Factor	$\Phi_{CO_2}$	CO <sub>2</sub> emission reduction (tCO <sub>2</sub> /annum)
$\Psi_{CO_2}$	CO <sub>2</sub> equivalent intensity	$c_{CO_2}$	Carbon price (\$)
$AEP$	expected annual energy produced	$R$	Discount rate (%)

UNDER