

# Mechanical analysis of large components of wheel type wind power crane

---

## ABSTRACT

Under the background of the goal of "carbon peak, carbon neutrality", China's wind power development gradually transfers from the three northern regions to the central and eastern parts of the south, wind power installed capacity continues to increase, wind turbine height and single capacity continue to improve, while facing complex geographical environments such as mountains, forest areas, fish ponds, farmland, the functional demand for wind turbine hoisting equipment is increasing day by day. Due to the backwardness of China's metal material manufacturing technology and large wind power crane detection technology, the fatigue life of wind power crane is unpredictable, often in dangerous working conditions and negative loads, resulting in boom fatigue damage, which has a significant impact on personnel safety and national and company economic losses.

Today, the demand for wind power has increased greatly, and the wind motor has changed from the previous slow speed, small wind blades and light weight to the single machine capacity is getting larger and larger, the blades are getting longer and longer, the tower height is getting higher and higher, and the lifting parts are getting heavier and heavier. This has created the characteristics of high, large and heavy wind turbines today. Therefore, the traditional wind turbine hoisting equipment has been unable to meet the needs of wind power construction, such as the all-ground crane high cost, weak wind resistance; Crawler crane lifting weight and lifting height is insufficient, and the site required for installation and demolition is large; The traditional tower crane needs to be attached to the tower barrel, which has low disassembly efficiency and great influence on the tower barrel, which seriously restricts the rapid development of wind power construction. Therefore, it is urgent to develop wind power cranes that can better adapt to complex geographical environments, ultra-high towers, and large megawatt units, while reducing installation costs and improving the safety and efficiency of hoisting, it is necessary to carry out mechanical analysis of wind power crane equipment.

*Keywords: Wheel type wind power crane; Finite element statics analysis; Finite element element method; ANSYS; Structural mechanics analysis*

## 1. INTRODUCTION

With the rapid development of economy, the social demand for energy is also increasing. The ensuing problems are all kinds of problems, environmental problems are the most prominent. For a long time, China's power development mainly relies on traditional energy, traditional energy is not renewable energy, the use of limited time, the pollution is often the most. Although the use of traditional energy solves the current power problem, taking into account the sustainable

development strategy and future development planning, it is necessary to open up a new development path of wind power. We know that wind power is a kind of clean and renewable energy, and the development and utilization of wind power is a strategic measure to solve China's energy problems and achieve "carbon peak and carbon neutrality".

China's energy development there is a long-term contradiction, China's short-term problems and long-term contradictions interplay, domestic and international factors affect each other, resources and environmental problems are particularly prominent, energy conservation and emission reduction situation is very serious, energy resources dependence on foreign countries is rising rapidly, energy control total, adjustment structure, security is facing new challenges. First, resource constraints are intensifying, and the situation of energy security is grim. Second, the constraints of the production environment are prominent, green development is imminent, the domestic production environment is difficult to continue to carry extensive development, the international pressure to cope with climate change is increasing, and there is an urgent need for green transformation development. Wind energy is a renewable energy with huge resource potential and relatively mature technology. Under the new situation of reducing greenhouse gases and coping with climate change, it has been paid more and more attention by all countries in the world, and has been developed and utilized on a large scale around the world.

In response to the green development trend in today's world, China actively promotes the development of wind power technology, and gradually replaces the position of traditional energy with wind power energy, laying a solid foundation for China's future development vision, and striving to transform China's blue sky and white cloud in the future. In the "13th Five-Year Plan for wind power Development", China mentions "promoting the technological progress of low-wind power, promoting the development and construction of conventional wind power and low-wind power according to local conditions", and "accelerating the development of onshore wind energy resources in central and eastern regions and southern regions". Actively make use of existing technologies, constantly improve and innovate, and vigorously invest in research and development in related fields. Horizontal research on the already mature crawler wind power crane technology creates a crane that is more suitable for the current environment, which is not only more efficient and safe than traditional, but also has the advantages of small size and large load.

For a long time, people have paid more attention to the economic benefits brought by wind power construction, but ignored its impact on the environment. First of all, the construction of the project will affect the local ecological environment, such as destroying vegetation, changing topography and geomorphology, resulting in soil erosion; Secondly, the operation of the project will produce electromagnetic nuclear radiation and noise; Third, the construction of the project may cause landscape impact on local cultural relics; Finally, the impact of supporting projects, such as roads and living areas, on ecology, water and atmosphere should also be considered.

This paper mainly modeling the new wind power crane as a whole, simplifying the model, selecting different working conditions, adding loads to the model, and carrying out static analysis. Further verify whether the structural design of the new wind power crane is reasonable or safe.

## **2. RESEARCH STATUS OF WIND POWER CRANE AT HOME AND ABROAD**

There are many manufacturers of large wind power cranes in China. Including Sany Heavy Industry, new Dafang, Zoomlion, Xugong and other large crane companies, in which the product models are diverse, in response to different working conditions in different regions, can find the corresponding type of crane, these large crane companies, the market share is high. In recent years, the domestic policy stimulus has accelerated the research and development process of large wind power cranes. Through technological innovation, theoretical innovation and leapfrog development, the company has made leaps in various industries [1].

At present, the foreign crane industry is also developing rapidly, especially the wind crane equipment type company, Manitowoc (Manitowoc) is the main manufacturer of cranes in the United States, the company mainly produces 45t to 907t lifting weight cranes, the company's production equipment to water-cooled diesel engine as power, the use of controlled torque converter (VICON system), In order to improve the lifting capacity, the company used a ring rail type lifting device, in addition, in order to change its lifting weight at will during the installation process, the company equipped the equipment with variable counterweight rating, Kobelco is Japan's first research and development crane leader, early, the company developed the 3000 series fame, during the company developed the 5000 series, In particular, the 5650 crane, with a maximum lifting weight of 650t, was later upgraded to the CKE series of high-performance cranes by improving the 7000 series, and the lifting weight of the 7000 series was developed from 35t to 800t, and the product performance was higher guaranteed [2].

## **3. INTRODUCTION AND THEORETICAL ANALYSIS OF FINITE ELEMENT SOFTWARE ANSYS**

### **3.1 OVERVIEW OF FINITE ELEMENT METHOD**

In the early 1960s, the famous Clough first proposed the "finite element method", with the rapid development of computer science and technology and the formation of basic finite element theory. Nowadays, the finite element method has become the most widely used analysis method in high-tech fields such as industrial machinery. The central idea of finite element is to discretize the structure into small units. In other words, if the solid model is dispersed into a limited number of regular units, the physical properties of the solid model can be summarized by analyzing the physical structure of these units, which greatly increases the approximate results of engineering finite element analysis. The finite element method can improve the calculation accuracy and shorten the calculation time greatly by replacing the actual model structure analysis with the unit rule structure entity. With the change of times and the rapid development of computer technology, this idea has become an important part of engineering design and industrial manufacturing.

The analysis and calculation ideas of finite element method can be summarized as follows:

- (1) Discrete structure, that is, from different perspectives of thinking, the overall entity organization analysis is transferred to a finite number of rule unit analysis. This is done by dividing the entity model into finite units of rules.
- (2) Unit analysis, that is, by dividing the entity into a limited number of element units, then analyzing each element, and analyzing the entire entity structure through the characteristics of each element, the displacement of nodes between elements is often used to explain the stress and strain of all points in the entire structure.
- (3) Overall analysis: Through unit analysis, we get the structural characteristics of nodes between each element. Overall analysis can be understood as combining each element in unit analysis into a model whole and analyzing the model as a whole, because we solve the node displacement between each element. By establishing effective equations and integrating the displacement, stress and strain, the corresponding data can be obtained by solving the equations.

The core idea of the finite element method is to discretize the structure of the model, that is to say, the solving part is divided into several small units, which are connected to each other through the connection points, so that the subdomain approximate solution of the basic equation of the model can be solved [3]. The finite element method can be divided into the following processes:

1. The overall model is divided into several continuous regions, and the regions between them are usually connected together by common nodes of the boundary, and become a whole. These areas are called cells. We found that the larger the number of cells, the denser and smaller the size, the more accurate the results of the later calculation.
2. In the solution domain, we convert unsolved problems into other parts for solving, which are generally problems with infinite degrees of freedom, and convert them into numerical values of each node or other functions for solving [4].

3. The functions solved by each unit are processed and integrated together to obtain effective unit node equations, which are aggregated, and then the formed finite element equations are solved [5].

### **3.2 Finite element analysis software ANSYS**

The progress and development of modern science, buildings, vehicles, Bridges, lifting equipment and generator sets and other equipment development is also very rapid, for these mechanical equipment, engineers in the early design, not only to meet the design requirements, predict the design performance of the product, but also to make its structural safety performance meet the national standard, This requires calculation and analysis of technical parameters such as statics, dynamic strength, temperature and flow field of design products. Traditional design methods are often impractical and inefficient, so a new design method is needed to solve the problem. ANSYS was developed to solve these problems. ANSYS software has a powerful analysis and optimization ability, is developed by an ANSYS company in the United States, widely used in various fields, with static analysis, dynamic analysis, modal analysis and other functions to solve the urgent needs of current engineers, and lay the foundation for further upgrading of equipment. ANSYS finite element analysis software mainly consists of three modules: CAE modeling tools, analysis tools and optimization tools, the three modules are set in one page, data sharing, mutual transfer and call, convenient for engineers to design and use.

At present, there are many finite element software in the field of finite element analysis, mainly including NASTRAN, ADINA, ANSYS, ABAQUS, MARC, HYPERMESH, etc. After comparing the advantages and disadvantages of different finite element analysis software, it is found that HyperMesh software has a powerful function in model pre-processing mesh division. Therefore, this paper uses ANSYS software to carry out pre-grid division processing for the new wind power lifting equipment, and then carries out static and dynamic analysis.

Due to the rapid development of aerospace, machinery, chemical industry, new energy, shipbuilding, national defense and other high-tech fields, finite element analysis has become a key step that they must consider, so the software ANSYS has become a wide range of attention. It has the most outstanding advantages in the formation of simulation graphics, and it can clearly show a variety of complex simulation image results. For example, graph, grid diagram, modal analysis diagram, cloud diagram, etc.

## **4. STATIC ANALYSIS OF NEW WIND POWER CRANE BASED ON ANSYS**

### **4.1 Finite element modeling of wind power crane**

According to Chapter 2, there are three existing boom structures of traditional wind power lifting equipment, which are main boom combination form, tower boom combination form and auxiliary boom combination form. In this paper, the new QLY 106t tire crane is the main research object, and its boom structure is tower boom combination, which has the characteristics of large working radius, strong lifting capacity and strong wind resistance. The structure of wind power equipment crane mainly includes tower body, tower, chassis boom, balance arm, turntable, rotary system and amplitude changing mechanism [7]. The chassis structure includes legs, off, on, control room, generator and other devices. This article uses the 3D modeling software SolidWorks, refer to the relevant literature. According to the designed data, the new QLY 106t tire crane is modeled in 3D. The 3D modeling model of wind power crane by SolidWorks is shown in Figure 4-1. Among them, 1, machine 2, leveling mechanism 3, tower body 4, support arm system 5, lifting arm 6, power system, hydraulic system, electrical system 7, swing arm 8, hook group 9, variable amplitude wire rope 10, cable 11, main winding wire rope.

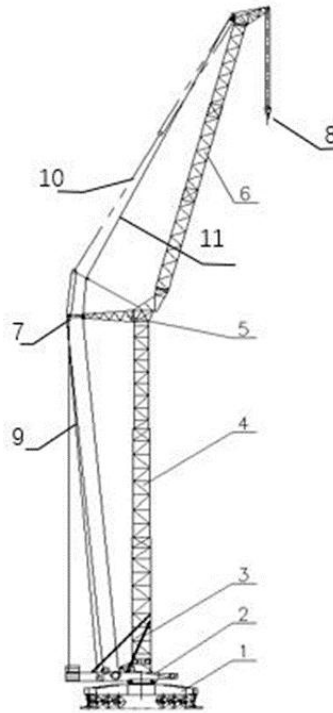

Fig. 1. Machine structure drawing

#### 4.2 Wind crane load handling

Wind power generation crane half of the working environment in a strong wind environment for operation, the operation process not only to bear their own huge load but also to resist the impact of wind load, and under the influence of these factors but also to carry out lifting, boarding, getting off, amplitude, walking and lifting operations, bearing variable loads, wind power crane as a whole by the load can be divided into three categories of load. One is a conventional load, one is an accidental load, and the other can be divided into special loads. The conventional load generally refers to the overall force of the wind power crane when it is working normally. Accidental load is generally not easy to appear, in the conventional operation process, accidental load does not often appear, so in the static analysis process of wind power crane, it is often not considered. Special load refers to a load that occurs outside of its own gravity and working pressure, and is only considered as an influencing factor under rated working conditions, and the general operation process is not considered. According to several working conditions of wind power crane, the main load is divided into the following types [8][9][10] :

1. self-weight load  $F_G$

The self-weight load of the wind power crane is generally composed of the overall component gravity, the overall structure is mostly composed of metal, its own weight on the whole generated self-weight load, self-weight load generally includes components metal weight, steel wire rope weight, electrical equipment weight, boom weight and tire weight. This calculation mainly adopts the finite element method, the self-weight load is automatically considered through the input material density and the loading gravity acceleration, and the self-weight of each component and its center of gravity position are separately considered when checking the stability of the whole machine, which are estimated by hand.

2. lifted load  $F_Q$  dynamic coefficient  $\phi_2$

The lifting load is taken into account in the calculation of statics analysis. During the operation of the wind power crane, the lifting weight changes from zero to full load, and the load state changes accordingly. The dynamic effect of heavy objects will have an impact on the overall structure. The dynamic effect of lifting load changes in the process of lifting heavy objects, sometimes increasing instantly, or sometimes increasing gradually. Lifting load  $F_Q$  generally refers to the weight of lifting heavy objects, but the weight of the wire rope also needs to be taken into account, its weight is calculated according to the lifting height, and 50% of the gravity is used as the lifting load, but if the lifting height is less than 50m, the weight of the wire rope can not be considered [11]. Therefore, the lifting load impact coefficient  $\phi_2$  is introduced, and the dynamic coefficient  $\phi_2$  is shown in the figure.2.

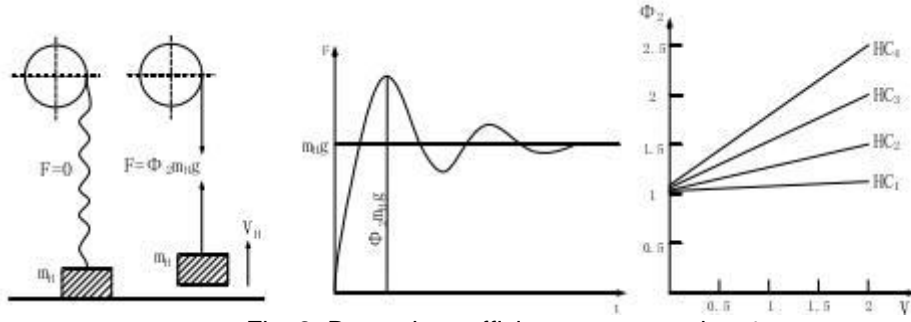

Fig. 2. Dynamic coefficient representation  $\phi_2$

$$\phi_2 = \phi_{2min} + \beta_2 v_{\dot{h}} \#(1)$$

$$F_G = Q\phi_2 = \phi_2 \cdot g C_p \#(2)$$

Through literature review, we can see that the dynamic characteristics of wind power cranes and elastic characteristics of materials are divided into four levels, which are divided into HC1~ HC4. According to the lifting state of the wind power crane can be divided into four characteristics classification. The lifting state is shown in Table 1, According to GB/T 3811-2008, the lifting state is HC1, which can be obtained by formula (1) :

$$\phi_2 = \phi_{2min} + \beta_2 v_{\dot{h}} = 1.05 + 0.17 \times 22 / 66 = 1.11$$

Dynamic load test load lifting dynamic load coefficient:

$$\phi_6 = 0.5(\phi_2 + 1) = 1.055$$

**Table 1. Raises the status level**

Raises the status level	$\beta_2$	$\phi_{2min}$
HC <sub>1</sub>	0.17	1.05
HC <sub>2</sub>	0.34	1.10
HC <sub>3</sub>	0.51	1.15
HC <sub>4</sub>	0.68	1.30

### 3. Inertial load

The crane works with legs, so the walking inertia force is not considered when working. The centrifugal force has a load reduction effect on the structure, which can be ignored. In the following, the inertial load is applied to the corresponding structural node in the form of concentrated force in the finite element calculation.

(1) The rotary inertia force generated by the lifting load mass is:

$$F_{BQ} = \frac{F_Q n \pi R}{30gt} \#(3)$$

(2) When rotating lifting (braking), the tangential inertial load of the boom is:

$$P_{HG} = \frac{G_b}{g} \times \frac{\pi n}{60t} \times (l + R) \#(4)$$

### 4. Wind load [13]

The working environment of wind power equipment crane is complex, generally in strong wind areas, because the wind power equipment crane contact wind area is large, the overall stability is affected by wind load. In order to work stably, wind load should be taken into account [14][15].

$$P_w = p_w CA \#(5)$$

## 4.3 Material selection and working conditions of structural members

The bearing capacity of the whole component is different at different positions. In order to achieve large bearing capacity and save materials, different materials are selected for different components. The plate and beam structure (off structure and machine structure) and the main chord rod of the swinging mast and horizontal support arm are made of Q345C and Q460D steel, the tower body and boom are made of Q690D steel, and the main pipe of the truss is made of HSM770 steel. The density of Q345 steel is 7.85 × 103kg /m3, Young's modulus is 206GPa, Poisson's ratio is 0.3, the yield strength is 345MPa, and the tensile strength is 470-630MPa. The allowable stresses of the material are shown in Table 2.

**Table 2 Allowable stress (MPa) of steel when the safety factor is 1.34**

Materials	Thickness / mm	Stretch, compress, bend [ $\sigma$ ]	Shear [ $\tau$ ]	End pressure [ $\sigma_{cd}$ ]
-----------	----------------	---	---------------------	-----------------------------------

Q34	> 16 ~ 3	242.5	148.6	360.4
5C	> 35 ~ 5	220.1	140	339.6
HS M770	≤ 16	509.3	294.1	713.1
Q46	≤ 16	343.3	198.2	480.6
0D	> 16 ~ 3	328.4	189.6	459.7
Q69	≤ 16	458.6	264.8	642.1
0D	> 16 ~ 3	451.1	260.4	631.5

In order to verify the certainty and safety of the design parameters, according to the designed parameters of the new QLY 106t tire crane, the maximum amplitude and minimum amplitude corresponding to the maximum lifting weight, as well as the intermediate amplitude are selected to verify the rationality of the data and the stability and safety of the overall mechanism. In this paper, special working conditions of wind power equipment were selected for checking calculation. The working conditions were R=16.5m working range rated lifting weight Q=106t, and lifting impact and lateral vertical wind were considered.

#### 4.4 Static analysis and results of wind power crane

The working condition is R=16.5m working range lifting rated weight Q=106t, considering lifting impact and lateral vertical wind, the calculation results are shown in FIG. 3, FIG. 4, FIG.5.

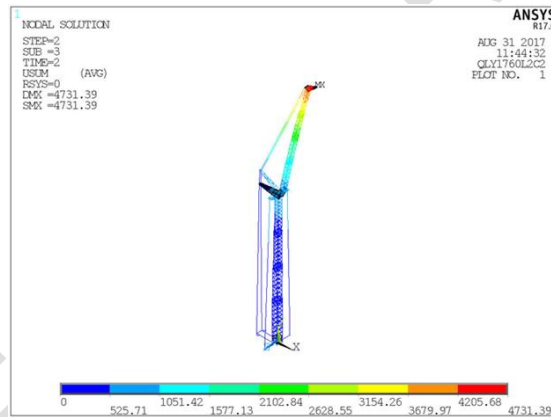

Fig. 3. Nephogram of structural stress result of tower crane

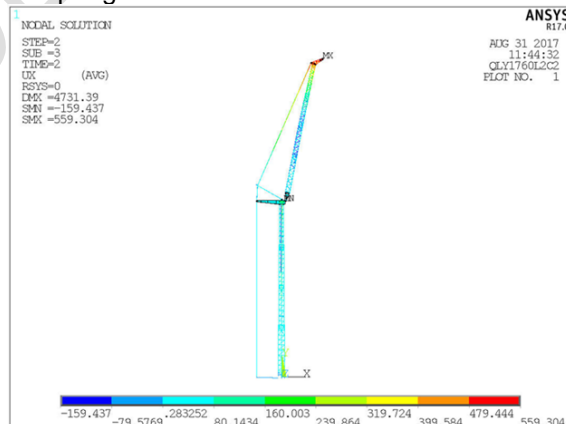

Fig. 4. Cloud image of tower crane deformation result

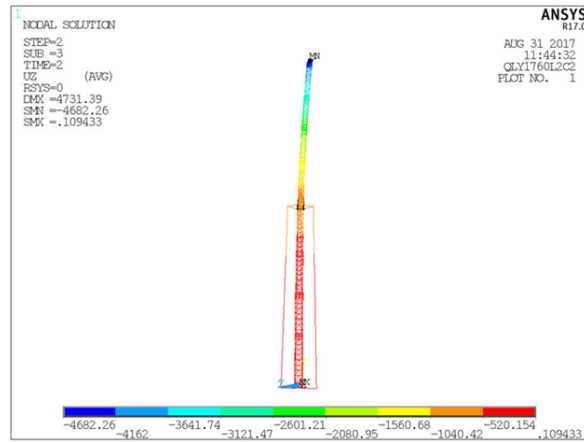

Fig. 5. Result of tower crane rotation plane deformation cloud image

## 5. CONCLUSION

According to the numerical simulation results of the above working conditions, the maximum stress position of the tower is 285MPa, which occurs in the hole of the ear plate at the intersection of the boom and the frame. The ear plate is made of Q345 material with a thickness of 50mm, which exceeds the allowable stress of the material of 250MPa, but is less than the yield stress of the structural material of 345MPa. This is a stress singularity, and the extreme stress region is very small, and the surrounding stress is less than the allowable stress of the material, and these extreme stress regions do not affect the overall stress state of the member. In addition, the local stress concentration of the plastic material under load will be greatly alleviated due to the local plastic deformation of the structure, and the concentrated stress area is small, and the stress value near it is low, so the local stress concentration has almost no impact on the structural strength, so the overall structural strength of the tower meets the requirements of the code. The Y direction is the vertical direction, the maximum displacement is -293mm, and the X direction is the horizontal direction, the maximum displacement is 1503mm, less than 1575mm, and the rigidity meets the specification requirements.

According to the design requirements of "wind power Crane design Criteria", the parameters of the new wind power crane are designed, and the three-dimensional model is established according to the data, and the finite element model is established according to the three-dimensional model. According to several typical working conditions of wind power crane, the whole finite element model is analyzed statically, and the specific displacement and stress data graphs are obtained. According to the analysis results, whether the design parameters meet the requirements of the criteria is calculated. Through the analysis and calculation of working conditions, the whole model meets the design requirements and achieves the specific safety standards. The key parts and the parts with large force were analyzed separately, and the analysis results were in line with the design standards.

## REFERENCES

1. Chen Chi-zhong, Luo Huixin. Analysis of Cracking Causes of Long-Span Bridge Crane Balancing Trolley [J]. Foundry Technology, 2011, 32(07): 1001-1004.
2. Wang Fengping, Cheng Lei, Sun Ying. Current situation and Development Trend of crawler Crane at home and abroad [J]. Construction Machinery, 2006, (04): 39-43+6.
3. Mechanical Design Manual - 6, Modern Design methods and applications. China Machine Press
4. Li Baohua. Research on static and Dynamic Characteristics of arm structure based on Finite element Method [D]. Southwest Jiaotong University, 2009.
5. TANG Qian. Design and analysis of spherical joint for deep water drilling [D]. Southwest Petroleum University, 2018.
6. Krejal, Mikulski T, Szymczak C. Application of superelements in static analysis of thin-walled structures [J]. Journal of Civil Engineering and Management, 2004, 10(2): 113-122.
7. SUN Gang. Research on Key Technologies of Wind Power Crane [D]. Jilin University, 2013.
8. Guo Yunzhi. Research on Metal Structure Design of Crane based on Limit state Method [D]. Dalian University of Technology, 2006.
9. Zhang Liying, Zhao Xinzhe, Wu Jiansong. Application of ANSYS in Structure Analysis of Tower Crane [J]. Construction Mechanization, 2004, (09): 57-59.
10. Sheng Huanming, Huang Shan, Chen Jinghong et al. Research on Vertical Load Bearing Mechanism of multi-layer hollow steel truss [J]. Journal of Southwest University of Science and Technology, 2013, 28 (04): 11-17.

11. Zhu Juzhen. Failure and Detection of Metal Structure of Lifting Machinery [J]. Port Loading and Unloading, 1995, (01): 17-18.
12. Han Chongrui. Based on the coupled dynamics simulation analysis of the fatigue life of tower crane [D]. Beijing architectural university, 2021. The DOI: 10.26943 / , dc nki. GBJZC. 2021.000186.
13. Jiang T, Xue G Y, You Y P. Study on the Impact of Wind Load on Large Crawler Crane Typical Truss Structure[J]. Advanced Materials Research, 2011, 295-297: 2133-2136.
14. Xu Shudong. Application of Finite element Technique in Structural Analysis of Tower Crane [J]. Construction Mechanization, 2006, (03): 21-22+25.
15. T.G.Mara Effects of a Construction Tower Crane on the wind loading of a High-Rise Building[J]. Journal of Structural Engineering .2010(11):1453-1460.

UNDER PEER REVIEW