

Advancing Manufacturing Efficiency through Real-Time Production Monitoring and Control Systems

ABSTRACT

The advantages of both real-time production monitoring and control systems in enhancing the advancement of manufacturing efficiency cannot be overlooked. Manufacturing industries need to meet customers' demand while still maximizing their profits via avoiding emergency shutdown of plants during production. Nonetheless, quality products with high purity level should be supplied uninterruptedly without breakage of supply chain. In recent times, failure of many of manufacturing industries to deliver their products to end users have been cited and reported. This was due to inadequate scheduling which was not being monitored via real-time production and control systems. There is need to tackle this problem which calls for the adoption of real-time production monitoring and control systems. In this paper, the concepts behind the use of real-time production monitoring and control systems were discussed. Consideration was given to how real-time production monitoring can be integrated in manufacturing. The features of real-time control systems were discussed alongside with their industrial applications in various disciplines of Engineering. Data analysis and prognostics, data collection, visualization module and data storage were identified as the relevant sequential steps in real time production monitoring in advancing manufacturing efficiency. In conclusion, the significance and importance of real-time production monitoring and control systems in advancing manufacturing efficiency have been revealed and discussed in this paper.

Keywords: Control systems, Production monitoring, Real-time, Manufacturing, Data collection

1. INTRODUCTION

The role of manufacturing in global industrialization cannot be underestimated due to the customer's demand in getting products with better quality and highest level of purity. Not only this, manufacturers of goods also need to find strategic ways of surpassing customers' anticipations in today's business world. Thus, it is imperative for manufacturing industries to run sustainable productions for the consumers for longer duration while still putting their tasks completion and quality products making into considerations. There are possibilities of market conditions changing with requirements with products possessing shorter life cycle [1]. Under this, mass customization trend poses several tests in manufacturing. It is necessary that manufacturing industries should respond in an adaptive way such as customers' demand and products requirements are not jeopardized in any way [2]. To attain these targets, manufacturing in the real world should be subjected into a competitive environment such that customers will have the free will to decide on best quality products made available as at when needed.

“Manufacturers should implement new technologies and move towards automation in order to keep up with the changing and unanticipated demands from the emerging market needs” [3]. “To meet the market fluctuating requirements, production processes must be regularly changed and made adaptable and agile as possible. Manufacturers can utilize the internet of thing to make provision for the current production modification process via electronics integration. One of the ways of achieving manufacturing automation is via Cloud manufacturing which is a process that employs well stabilized manufacturing resources such as Enterprise Resource Planning via the cloud and controlled it at any time or place. Cloud manufacturing gives room to immediate deployment achievement via the automation of the communication between manufacturing, scheduling, and accounting. It involves software deployment on the cloud i.e. “manufacturing version” of computing and check on the outlook, cutting across production, management, design, and engineering abilities in manufacturing business” [4]. With this, real-time production monitoring and control systems are required to further advance manufacturing efficiency.

1.1 Real-Time Production Monitoring Systems

“In manufacturing, real-time production monitoring systems (PMS) is a substitute to manual data collection and captures most of the required production data without human interference. In the current world, the high level of competitiveness among manufacturers in the market does not afford them the opportunity to waste time and resources in performing tasks that could be executed in a better and faster way with advanced solutions. The real-time production monitoring is one of the ways via which this problem can be tackled. This is a production tool that collects necessary data and distributes them when various activities are occurring during manufacturing. The main objective of this technique is to avoid small disturbances possessing large effects such that the number of unscheduled production stops are drastically reduced with improved cost-efficiency and simplified production planning” [5]. The main function of a real-time PMS is to collect real time data of events and distribute them during manufacturing. The data must however be understandable and applicable for decision making.

“The production team in a manufacturing company should be able to utilize the data in responding quickly to occurrences that may hinder the intended result. Such system should also alarm and notify the respective department concerning all identified faults. PMS is not only displaying boards indicating production data but also a reporting and administration module in which data can be stored and analyzed to discover trends. Such trends can be estimated and projected for knowledge-based decision making and production planning. Faults which are proactively detected will minimize time wastage and increase the overall equipment efficiency. One of the manufacturing execution systems functions is the production monitoring and machine data collection” [6].

“Production monitoring data can be categorized into two main groups which are status of resources and status of jobs. Status of jobs is associated with data of each completed task, evaluated production time, sequences and so on. It gives information about the arranged flow for improvement of production sequences. Real time overview of the production process allows paperless reporting method. Thus, comparison of planned and actual production numbers is possible at any period and allows more realistic scheduling that will assist in meeting delivery deadlines. The second group, the so-called status of resources, is relatively connected to personnel, machinery and working environment monitoring. Figure 1 is the production monitoring system classification. Under this, the machine event monitoring indicates machine workload, availability, downtime and performance. If the machine is not working, operators know the exact reason behind this and can rearrange the planned operations quickly, which saves time and cost. Such data give detailed real-time and

historical information of what is/was happening with the machinery during manufacturing. Personnel monitoring covers optimal movements tracking; planned versus actual manpower data and so on. Different indoor positioning systems may be utilized for people and tracking of equipment location that is part of the global production effectiveness concept. Working environment is seen here as a part of the “status of resources” group, as it influences the personnel comfort and safety” [7].

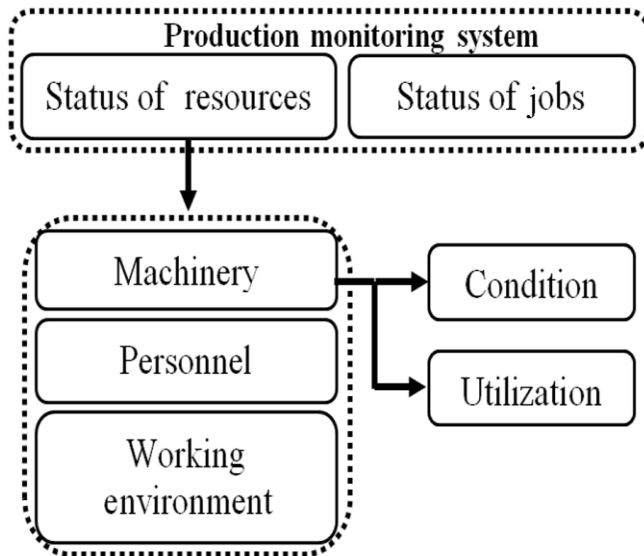

Figure 1: Production monitoring system classification [8]

1.2 Real-Time Control Systems

A system in which the time where the outputs are produced within a significant period of time is usually referred to as “A Real-Time Control System”. The outputs are expected to be produced within specified time constraints called “deadlines”. “The correctness of a Real-Time Control System is a function of the logical results produced and the times at which such results were produced. If a correct result is produced too early or too late with respect to the deadlines, the system may enter an incorrect state. A block diagram of a typical real time control system is shown in Figure 2. Sources such as switches, sensors, keyboard and communication links may be the origin of the inputs while the outputs may go to alarms, actuators, lamps, motors, communication links, or displays” [9]. Outputs of the system have associated time bounds within which they must be produced. The two main classes of real-time control systems are hard real-time systems and soft real-time systems. For hard real-time control systems, it is absolutely necessary that responses occur within the specified deadlines while in soft real-time control systems, response times are essential, but the system will still act correctly if deadlines are sometimes missed.

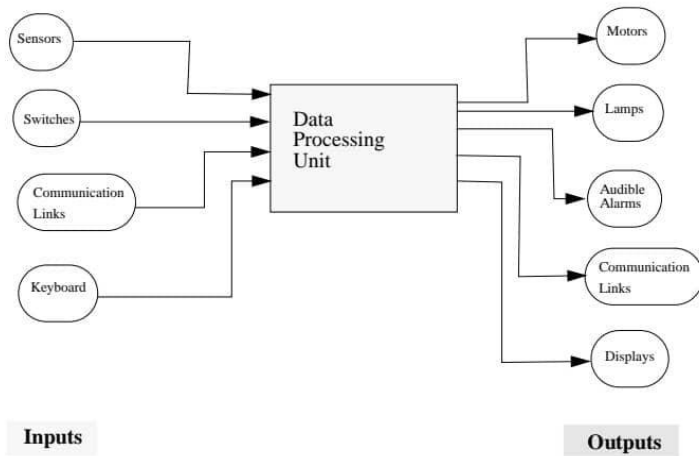

Figure 2: Block diagram of a typical real time control system [10]

“In recent times, more flexible control systems have been developed using applied digital computers within existing control loop which includes advanced algorithms and higher-level functions. Additionally, most current complex control systems could not be applied in the absence of digital hardware. However, the simple sequence sensing–control–actuation for the classical feedback control becomes more complicated as well. Nowadays, this sequence can be supplemented as follow: sensing–data acquisition–control law calculation–actuation–data base update. An overview of such control systems is displayed in Figure 3. With this, the control system now contains both the wired components and the applicable algorithms, which must be adequately programmed” [11]. Thus, the control loop now has the presence of software. This paper critically examines the contributions of both real-time production monitoring and control systems to advancing manufacturing efficiency.

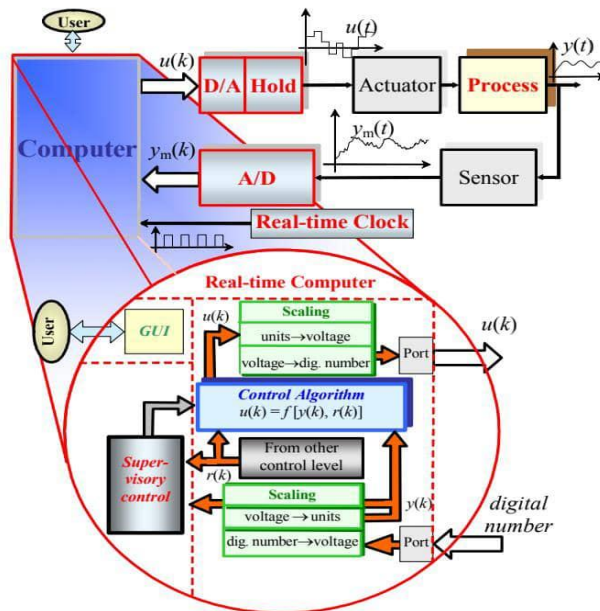

Figure 3: A real-time computer-controlled system [12]

2.0 The Theory of Real-Time Production Monitoring System

Human intervention or improper production monitoring system (PMS) can cause incorrectness of production data collected during manufacturing. Thus, it is imperative that PMS should capture many of the required data in the absence of human intervention. Some appreciable time is spent on the support resource to address the issue, troubleshooting and in resolving the problem when an unexpected outage happens. To avoid this, predictive nature of continuous remote monitoring is applied such that the issues are addressed before the machine operation and product quality are affected. The advantage an efficient real time PMS installation is the instant access to all the required information that is related to production by the concerned personnel. To achieve this, enough data should be made available to clearly identify the reasons behind stoppage in production, time loss and so on. Nonetheless, the presentation of too much information can lead to confusion and distraction of operators on duty. Accuracy, economical and ease of setting up on a production line of a system are the most significant requirements to any PMS. "Also, it should be capable of providing straightforward connection with sensors, switches, PLC outputs and other common industrial equipment. The true production data are part of the integral part of the improvement process if they can be automatically captured and presented in a simple and comprehensive way to the operators. It has been shown that relatively simpler systems possess greater potential for real-time control" [13].

As shown in Figure 4, the elements of an effective production monitoring system in a sequential order include collection, display, analysis, prognoses, and data storage. In the current development model, the added prognoses module gives the company additional flexibility such that both short term planning (automatic alarming of PMS system when some critical parameters reach the limit) and long-term planning (to forecast future defects and tool lifetime) are involved. The actual defects can be avoided using the available information and prognoses module while the maintenance is adequately planned such that the change of the wearing can be executed before it becomes completely broken. One of the basic capabilities of a PMS is an efficient alarm system. The personnel should properly understand the fault announcement to act timely during manufacturing operation. An advanced PMS should make provision for the possibility to review the history of the alarms. Displays, mobile solutions (like smart phones), andon boards and so can be utilized to execute data visualization [14].

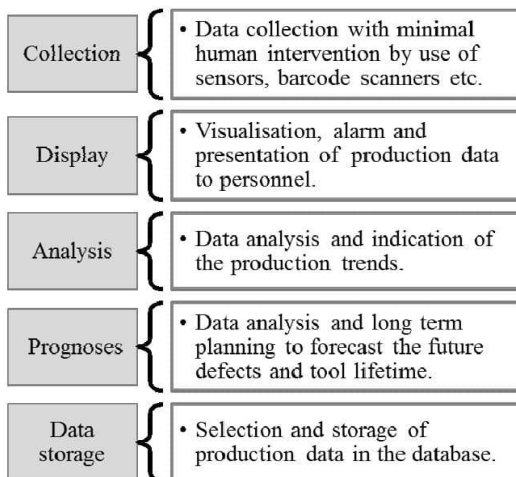

Figure 4: Elements of an effective production monitoring system [13]

2.1 Integration of Real-Time Production Monitoring System in Manufacturing

High cost of deployment of automated manufacturing systems has greatly been a major cause of most manufacturing machines not to be integrated. Many production industries still collect most of the data during manufacturing via manual inputs. Despite the offer rendered and made available by many automation providers to manufacturing execution systems solutions, most of the systems are insufficiently configurable, monolithic and difficult to modify. The installation of such software and integration with current systems is usually costly undertaking and challenging. Localized solutions can be more affordable and strengthen the advantages of automated production monitoring. Especially during the economic recession, many companies would prefer to weigh the benefits and shortcomings of investing money in a new production system. A faster return on investments can be the decisive moment during the selection of a production monitoring system. However, alternative manufacturing execution systems can provide a wide range of additional functions [12].

The cost evaluation of a PMS requires calculating the costs associated to both the software and hardware investments. Possible consultation and support costs must be taken into account. The costs can be decreased if a system is developed and integrated in cooperation with the production team. For modern manufacturing equipment, a monitoring system is assumed to be a part of the machinery. One of the major solutions to this is the installation of wireless sensors (smart dust) on machinery. Before this is done, models that perfectly reflect the interrelation between the monitored parameter and the state of the machine should be developed. These will enhance failures detection and critical modes of operation. The installation of a monitoring system, based on wireless sensor nodes, is relatively cheap. It can be fitted to both old and modern manufacturing equipment. The cost of cables is usually eliminated by wireless sensors and this simplifies the installation.

2.2 Features of Real-Time Control Systems

A real-time control system is usually applied within a larger system to make provision for control, monitoring and computation purposes. Such systems are termed embedded computer systems. They usually contain devices that act as the senses (such as heat sensors, light sensors and so on), and devices that act based on changes in physical properties (such as electromechanical, mechanical and electronic actuators). "The system is usually built around a micro-controller used for executing different control and system monitoring functions. The mechanism of operation of the system involves reading various sensors inputs, applies various filtering, calibration and processing of algorithms on the input data, and then produces output data to various actuators for implementations". [23]"An operator interface is provided to allow for manual instructions. Testing and maintenance of such systems can be done by special devices such as In Circuit Emulators. This is a device which monitors the real-time operations of a hardware micro-controller while executing the system software functions" [4]. Figure 5 is a block diagram of a typical embedded system.

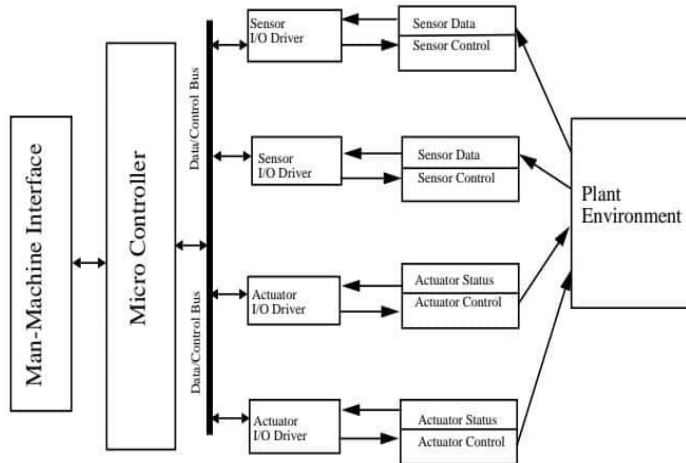

Figure 5: Block diagram of a typical embedded system

Another feature of real-time control system is the ability to process multiple inputs concurrently. This involves the correlation and processing of multiple inputs over the same time interval. A typical example of an industrial process control system is the correlation of temperature, pressure, and a concentration of a chemical reaction values to execute simultaneous adjustments of heaters and valves in order to maintain a reaction in the desired state. Concurrent tasks must be created and managed in order to fulfil the functions of a real-time control system [8]. One of the important aspects of managing concurrency is task scheduling. It is important to apply priority scheduling such that tasks with more stringent deadlines will be given higher priority before other tasks of less urgency in terms of scheduling on the central processing unit. This is necessary because tasks will compete simultaneously for the same central processing unit [2].

Nonetheless, with the support of human standards, the time scales of many real-time systems are fast. The complex devices monitored or controlled often operate in fast time scales. Also, the precision of response required for RTSs is greater than that required by other systems. An early or a late response may create erroneous behavior. An untimely shutdown of a chemical plant could cause extensive destruction to equipment or environmental destruction. Furthermore, RTS systems have higher reliability and safety requirements when compared with other systems. The failure of a system involved in automatic fund transfer between banks can cause millions of dollars being lost and failure in an embedded system could lead to failure of a vital life-support system. Lastly, RTS systems have special environmental, interfacing, and fault-tolerance requirements [13].

3.0 Sequential Steps in Real Time Production Monitoring in Advancing Manufacturing Efficiency

The various steps required for a successful real time production monitoring in advancing manufacturing efficiency include data analysis and prognostics; data collection; visualization module; and data storage.

3.0.1 Data Analysis and Prognostics

Useful information could be retrieved from the collected data via different techniques of data analysis. With the help of prognostics, inaccuracies and uncertainties are maximally

eliminated to determine the most likely scenarios. High value parameters are the major focus under this. Various developments in advanced sensor technologies and incipient fault detection techniques can be added. Additionally, a possible problem can be identified using different data mining techniques such as genetic algorithms, neural networks, decision trees and so on. Statistical process control (SPC) may be applied to evaluate the upper and lower limits. With these, operators can be easily informed about possible abnormal conditions. Such methods may be adopted in constructing control charts via the use of data measurements on a continuous scale [7]. Prognostics is becoming more prominent and can be widely applied in different disciplines. All the definitions describing prognostics are subject for further development and refinement. But most of the definitions agree on the prediction aspect. A prognostic is usually used to predict one of several related measures.

3.0.2 Data Collection

Key parameters from with the manufacturing plant should be decided for customers separately. Different methods may be adopted to pick proper data to be collected and visualized such as questionnaire, customer interview and so on. The presence of intrusive data inputs increases the risk of the system being rejected by the operators. This is imperative that information should be collected maximally in an automatic way. To get a readable data from a sensor in industry, signal conditioning module, analogue to digital converters and data loggers are used. Typically, total cost of this equipment is quite huge, but cost effective solutions are available. Preferably, wireless solutions should be adopted such as wireless sensor networks which help to reach difficult accessible locations by maximally removing wiring for faster installation [14]. Ways on how this network architecture may be implemented are numerous. Large networks can be disintegrated into clusters, where cluster could have either single-hop or multi-hop communication, as well as a combination of wired and wireless technologies. Only wired communication could be applied in more data-intensive operations or stringent environments [15].

3.0.3 Visualization Module

The procedure via which graphical user interface (GUI) is developed is closely related to data collection during manufacturing. The idea of visualization involves presentation of complex data in a simplified way. It is useful in finding patterns when large volume data are available to take quick decisions. Data visualization should be available between company's different units. Production monitoring system visualization module may be presented as a three-level structure. In manufacturing environment, it is not always ergonomic for operators to use keyboard and mouse. Thus, touchscreens may be preferred in some scenarios. But when developing GUI for touchscreens, not all "fundamentals" of mouse and keyboard interfaces should be used. In the case of big touch screens, operators will have to stretch their hands to reach the corner of the screen [16].

3.0.4 Data Storage

A data storage module is needed for data archiving, distribution and storage. On-site database server (SQL or NoSQL databases) or cloud-based platforms could be used to save collected data. Cloud storage is closely related to cloud computing which consist of various services such as platform, infrastructure and software. It may help in reducing the investment costs of the designed system. However, the responsiveness of the system is slow when compared with the on-site server. Different formats such as XML, ASCII, Database Files Binary and so on can be used to store data. Based on the application, they have their weaknesses and strengths [17]. Their application is a function of the data-streaming speed, file size, human readability and exchangeability. It also necessary to decide how long data

should be saved in the databases. Possible system expansion in the future should be considered, as it may bring changeover in database structures. Data should be protected (e.g., network security standards). As a preventive tool of user logging management, system privileges may be used. Policies inside the company should exist to maintain data protection [9]. In recent times, information about manufacturing smart industry has been presented [18]. Nonetheless, study by Gobinath et al. [19] presented an insight into information communication technology and intelligent manufacturing industries perspective.

3.1 Applications of real-time control systems in advancing manufacturing efficiency

Real-time control system has wide range of industrial applications and has been successfully applied in advancing manufacturing efficiencies in various diversities of engineering processes such as monitoring and control of electric utility, metal production, water treatment, data communication, aviation and space and petrochemicals production.

3.1.1 Monitoring and Control of Electric Utility

The high cost of fuels in running combustible engines in the industries has necessitated the application of real-time control systems to avoid sudden and unscheduled power outage in the process of managing fuel. Thus, application of computers to monitor and control industrial plant equipment is highly important. This will ensure optimal operation and safety, and also curb costly sudden outages. Oil is usually consumed in large quantities in the utilities plants by some equipment such as the boilers, compressors and so on. A slight deviation from the optimal efficient performance, even for a very short time during manufacturing, by the aforementioned equipment can have serious influence on the electrical energy cost. To prevent this from happening, many manufacturing industries usually adopt the use of supervisory control and data acquisition system called SCADA to manage the energy consumption by electric utilities. This helps in estimating and predicting energy demand and hence can outline the planning process for energy generations to overcome networks overloading deficiencies [20].

3.1.2 Metal Producing Industry

The major processes involved in metal production include hot rolling, casting, annealing, cold rolling, soaking, finishing and other applicable metal processing activities. In all these, real-time control system is usually applied to control the processes. The major requirements for real-time control systems in this type of manufacturing industries are: (1) real-time monitoring and control, (2) high availability and reliability for functional redundancy at all stages of monitoring, control and processing and lastly (3) broad range communications of distributed control systems with corporate host computers and programmable logic devices [21].

3.1.3 Aviation and Space

This is typically applicable in Aeronautical Engineering such that computers are used to monitor and control transportation systems especially in civilian and military aeroplane and space shuttle missions. Not only this, real-time control system is applied in aerodynamic and structural testing and simulation in the course of developing space shuttles and aeroplane. In planetary exploration applications, the adopted mechanisms by real-time control system involves data collection and their analysis from space exploration missions which are used as simulators and real-time trainers. Unmanned flights have been extensively used for space explorations. This is impossible without the complex command and control provided by the

real-time control system. This is a combination of computer network on the ground and on the flight instrumentation system present in space [11].

3.1.4 Petrochemical Manufacturing Industries

This is applicable to Chemical and Petroleum Engineering fields which produce essential chemicals such as ammonia, polyvinylchloride, sulphuric acid, ethylene glycol, propylene and so on. For efficient control and monitoring during the production of these chemicals, real-time control system is needed. The production of these chemicals require high performance real-time features and there should be provision for interfaces to regulatory control instrumentation systems and programmable logic controllers. Generally in petrochemical applications, safety is a key requirement to prevent and avoid failure which may lead to environmental disaster [17].

3.1.5 Water Treatment Plants

This is applicable to Environmental and Civil Engineering fields. The necessity for clean and safe water in various units of these fields has called for water treatment for reuse purposes. The major treatment processes that an untreated water undergo include coagulation, chemical injection, flocculation, aeration and filtration [20]. These require the utilization of real-time control system for effective control and process monitoring in fresh water plants. The mechanism involves water transmission via a network of reservoirs and laterals supported and decorated with pumping stations. Dual redundant computers are used to monitor and control the water system which also act as hosts to a large number of distributed satellite computers [21].

3.1.6 Telecommunication Industry

This is related to Computer and Electrical Engineering professions. Both international and local data communication networks utilize real-time control system as communication processors to offer key features of packet switched networks such as performance capabilities suitable for both background and on-line communication functions simultaneously, high speed real-time communication, as well as extensive line handling for communication protocols. The advances in communication technologies deliver an ever increasing complexity for data communication systems [22].

4. CONCLUSION

The concepts of real-time production monitoring and control systems have been discussed alongside the integration process required for real-time production monitoring in manufacturing industries. Consideration was given to important features of real-time control systems. Industrial applications of real-time control systems in controlling and monitoring electric utility, metal production, aviation and space, petrochemicals producing industries, water treatment plants and telecommunication industry were presented. Data analysis and prognostics, data collection, visualization module and data storage were identified as the relevant sequential steps in real time production monitoring in advancing manufacturing efficiency.

REFERENCES

- [1] Esmaeilian, B., Behdad, S., Wang, B. (2016) The evolution and future of manufacturing: A review. *Journal of Manufacturing Systems*, 39, 79-100.
- [2] Mourtzis, D., Papakostas, N., Mavrikios, D., Makris, S., Alexopoulos, K. (2013) The role of simulation in digital manufacturing: Applications and outlook. *International Journal of Computer Integrated Manufacturing*, 28, 3-24.
- [3] Sassanelli, C., Pezzotta, G., Rossi, M., Terzi, S., Cavalieri, S. (2015) Towards a Lean Product Service Systems (PSS) Design: State of the art, opportunities and challenges. *Computer Applications and Industry*, 30, 191-196.
- [4] de Ugarte, B., Ariba, A., Pellerin, R. (2009) Manufacturing execution system – A literature review. *Prod. Plan. Control*, 20, 525–539.
- [5] Zhang, Q., Hua, C., Xu, G. (2014) A mixture Weibull proportional hazard model for mechanical system failure prediction utilising lifetime and monitoring data. *Mech. Syst. Signal Process*, 43, 103–112.
- [6] Hashem, I. A. T., Yaqoob, I., Anuar, I. N. B., Mokhtar, S., Gani, A., Khan, S. U. (2015) The rise of “big data” on cloud computing: Review and open research issues. *Inform. Syst.*, 47, 98–115.
- [7] Lanza, G., Stoll, J., Stricker, N., Peters, S., Lorenz, C. (2013) Measuring global production effectiveness. *Procedia CIRP*, 7, 31–36.
- [8] Snatkin, A., Eiskop, T., Karjust, K., Majak, J. (2015) Production monitoring system development and modification. *Proceedings of the Estonian Academy of Sciences*, 64, 4S, 567–580.
- [9] Subramaniam, S., Husin, S., Singh, R. and Hamidon, A. (2009) Production monitoring system for monitoring the industrial shop floor performance. *Int. J. Syst. Appl. Eng. Developm.*, 3, 28–35.
- [10] Ryu, M., Hong, S., Saksena, M. (1997) Streamlining Real-Time Controller Design: From Performance Specifications to End-to-end Timing Constraints. Proc. IEEE 3rd Real Time Technology and Application Symposium, 1-99.
- [11] Cadavid, J.P.U., Lamouri, S., Grabot, B., Pellerin, R., Fortin, A. (2020) Machine learning applied in production planning and control: A state-of-the-art in the era of industry 4.0. *Journal of Intelligent Manufacturing*, 31: 1531–1558.
- [12] A. Gambier (2017) Real-time Control Systems: A Tutorial. Technical Paper.
- [13] Subramaniam, S., Husin, S., Singh, R., Hamidon, A. (2009) Production monitoring system for monitoring the industrial shop floor performance. *Int. J. Syst. Appl. Eng. Developm.*, 3, 28–35.
- [14] Bixler, T. S. (2008) Remote monitoring and expert diagnostic support for the pulp & paper industry. In Conference Record, 54th Annual Pulp and Paper Industry Technical Conference. Seattle, WA, 181–191.
- [15] Snatkin, A., Karjust, K., Majak, J., Aruväli, T., Eiskop, T. (2013) Real time production monitoring system in SME. *Estonian J. Eng.*, 19, 62–75.
- [16] Alexandru, C. and Gheorghe, G. (2015) Mechatronic architectures. AIP Conference Proceedings Volume 1648, 10 March 2015, Article number 620003. International Conference on Numerical Analysis and Applied Mathematics 2014, ICNAAM 2014; Rodos Palace Hotel Rhodes; Greece; 22-28 September 2014.
- [17] Juhas, M., Gulan, M., Neto, L., Gonçalves, G., Komenda, T., Pickel, L., Zhou, S., Schickling, C., Loksik, M., Morh, M. (2022) FactoRIS – A learning factories based education framework to support digital transformation of manufacturing SMEs, in: 12th Conference on Learning Factories, SSRN, 2022.
- [18] Kathirvel, A., Gopinath, V. M., Naren, K., Nithyanand, D., Nirmaladevi, K. (2024) Manufacturing Smart Industry Perspective an Overview. *American Journal of Engineering and Applied Sciences*, 17(1), 33-39. <https://doi.org/10.3844/ajeassp.2024.33.39>

[19] Gobinath, V. M., Ayyaswamy, K., Kathirvel, N. (2024) Information Communication Technology and Intelligent Manufacturing Industries Perspective: An Insight. *Asian Science Bulletin* 2, no. 1: 36-45. <https://doi.org/10.3923/asb.2024.36.45>

[20]FactorIS, Learning factories for digital transformation of SMEs, 2023. URL: <https://www.factoris.digital/>.

[21]Juhas, M., Gulan, M., Grandova, K. (2021) A learning factory concept for Slovak manufacturing SMEs, in: 11th Conference on Learning Factories, SSRN, 2021.

[22] Ng Corrales, L. C., Lamb´an, M. P., Hernandez Korner, M. E., Royo, J. (2020) Overall equipment effectiveness: Systematic literature review and overview of different approaches. *Applied Sciences*, 10.

[23] **Snatkin A, Eiskop T, Karjust K, Majak J. Production monitoring system development and modification. Proceedings of the Estonian Academy of Sciences. 2015 Oct 1;64(4):567.**

UNDER PEER REVIEW