

## **Original Research Article**

# **Intelligent Energy Management System: Harnessing Fuzzy Logic for Charge Control**

---

### **ABSTRACT**

**Aim:** Charge controller that leverages fuzzy logic was developed to enhance the efficiency of traditional charge controllers. A model was constructed and assessed for its performance through MATLAB/Simulink. It allows for flexibility in controlling the variability of renewable energy sources. It also improves the efficiency and lifespan of energy storage systems while minimizing the impact on the grid and environment.

**Study of the design:** The PV system consists of a PV module, PWM inverter, MPPT controller and DC-DC converter which are connected using Matlab-Simulink environment.

**Methodology:** we conducted validation tests to substantiate the advantages of our fuzzy charge controller. The creation of fuzzy rules was based on the system's performance and subsequently translated into precise values with the assistance of a fuzzy inference system.

**Results:** Our findings clearly demonstrate that the implementation of fuzzy logic control results in superior charge controller performance. This, in turn, safeguards against battery discharging and overcharging during unpredictable weather conditions.

**Conclusion:** These protective measures are made possible through the decision-making capabilities of the DC-DC buck-boost converter, which effectively regulates both the voltage and current output of the PV module.

*Keywords: controller, fuzzy logic, voltage, current, module*

## **I. INTRODUCTION**

Energy holds immense significance for both industrialization and human consumption. Many developing countries, like Nigeria, heavily rely on renewable energy sources, notably solar energy. Recent global depletion of fossil fuel reserves has prompted a shift towards diversifying energy sources, primarily focusing on renewables. The introduction of electric vehicles, batteries, and power banks has significantly elevated living standards for households. Among renewable sources, the photovoltaic (PV) system has gained substantial attention among researchers [1].

Addressing greenhouse gas emissions is a top priority for environmental regulatory bodies striving to establish sustainable, low-emission energy sources. Solar energy emerges as a highly promising and emission-free energy source, making it environmentally safe [2]. Solar energy is a consistently reliable source of renewable energy with numerous enduring benefits. However, the cost implications of PV systems have limited their accessibility to

some households. Hence, there's a need to design PV systems capable of harnessing maximum solar power regardless of weather conditions and to enhance the efficiency of power generation from solar PV panels [3][4][5].

One method to optimize power generation involves tracking the maximum power point by comparing the PV module's measured voltage with a reference voltage to adjust the duty cycle of the DC-DC converter. However, the conventional perturb and observe method used in PV modules tends to have a slow tracking speed as it perturbs the voltage to reach the maximum voltage [6].

Efficiency is paramount in areas with limited access to the electric grid where solar systems are widely adopted. Lead-acid batteries are commonly used in solar systems to meet these needs, but the absence of a suitable charge control system can lead to overcharging, which damages the batteries. To prevent this, a well-designed charge control system is necessary to cease charging once the maximum capacity is reached, preserving the storage energy capacity and extending the power supply service life. A promising alternative approach for controlling complex processes, particularly those challenging to analyze with conventional techniques, is the use of fuzzy logic controllers. In this research endeavor, a model has been developed to investigate the impact of fuzzy logic control on charge controllers under unpredictable weather conditions.

### Modeling Photovoltaic Systems

In this research study, the photovoltaic (PV) system comprises a PV module, a battery, and a DC-DC converter. The fuzzy logic Maximum Power Point Tracking (MPPT) control method determines the duty cycle (D) provided to the DC-DC converter, which it uses to regulate both current and voltage.

### Mathematical Representation of a Photovoltaic Module

In the realm of photovoltaics, the conversion of solar radiation into electricity occurs through the photovoltaic effect. As solar intensity increases, photons with energy exceeding the semiconductor's band gap energy create electron-hole pairs in proportion to the incident radiation. Figure 1 illustrates the equivalent circuit of a PV cell.

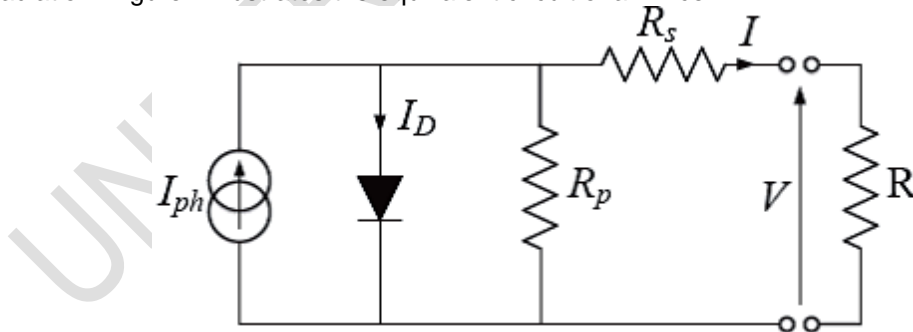

**Figure 1: Equivalent circuit of a PV cell**

As depicted in the above figure,  $I_{ph}$  corresponds to the photocurrent of the cell,  $R_{sh}$  signifies the cell's shunt resistance, and  $R_s$  represents the cell's series resistance. When multiple PV cells are combined, they form PV modules, and these modules can be interconnected in parallel-series configurations to create PV arrays. Equations (1) to (4) provide the

mathematical model equations for photovoltaic panels, as described in references [7] and [8].

For the module photocurrent,

$$I_{ph} = [I_{scr} + K_i(T - 298)] * \lambda / 1000$$

For module reverse saturation current,

$$I_{rs} = I_{scr} / [\exp(q \cdot \frac{V_{oc}}{N_s} \cdot k \cdot A \cdot T)]$$

Module saturation current  $I_s$  varies according to cell temperature, given as:

$$I_s = I_{rs} * \left[ \frac{T}{T_r} \right] * 3 * \exp[q * Ego \left( \left( \frac{1}{T_r} \right) - \left( \frac{1}{T} \right) \right)]$$

The PV module current is given as:

$$I_{pv} = N_p * I_{ph} - N_p * I_s \left[ \exp \left( \frac{q * V_{pv} + I_{pv} * R_s}{N_s * A * k * T} \right) \right]$$

Where,  $V_{PV} = V_{OC}$ ,  $N_p = 2$ ,  $N_s = 2$

In the equations above, various parameters are defined as follows:  $V_{PV}$  represents the output voltage of the PV module,  $V_{OC}$  stands for the open-circuit voltage,  $I_{pv}$  represents the output current of the PV module,  $T_r$  is the reference temperature,  $I_{ph}$  denotes the light-generated current,  $I_s$  corresponds to the saturation current of the PV module (in amperes),  $A$  is the ideality factor set at 1.6,  $K$  is the Boltzmann constant ( $1.3805 \times 10^{-23}$  J/K),  $q$  represents the charge of an electron ( $1.6 \times 10^{-19}$  C),  $R_s$  symbolizes the series resistance of the PV module,  $I_{scr}$  represents the short-circuit current of the PV module,  $K_i$  represents the temperature coefficient for short-circuit current ( $I_{scr} = 0.0017$  A/°C),  $\lambda$  represents the illumination of the PV module in watts per square meter ( $W/m^2$ ),  $Ego$  signifies the band gap energy for silicon at 1.1 eV,  $N_s$  represents the number of cells connected in series, and  $NP$  represents the number of cells connected in parallel.

In this research project, the 1Soltech 1STH-215-P PV module is chosen for the proposed model in MATLAB/Simulink. The specifications for the PV module, the DC-DC converter, and the battery are presented in Table 1 and Figure 2. The PV array is composed of two PV modules connected in series. Figure 3 and Figure 4 depict the variations in current-voltage (I-V) and power-voltage (P-V) outputs concerning changes in irradiation and temperature. Specifically, Figure 3 illustrates the fluctuations in current and power at various radiation levels under a constant temperature of 25°C, while Figure 4 displays the changes in current and power at different temperatures under a constant radiation level of 1000  $W/m^2$ .

**Table 1: Data specifications for the PV system**

PV Module		DC-DC converter		Battery	
Parameter	Value	Parameter	Value	Parameter	Value
$P_{max}(W)$	213.5	Output Capacitor (farad)	100e-6	State of Charge (SOC) %	65

<b>V<sub>oc</sub>(V)</b>	36.3	<b>Inductance(H)</b>	2e-3	<b>Nominal Voltage</b>	12
<b>I<sub>sc</sub>(A)</b>	7.84	<b>Input capacitor (farad)</b>	100e-4	<b>Rated Capacity</b>	100
<b>V<sub>mp</sub>(V)</b>	29	<b>Switch frequency (KHz)</b>	5	<b>Fully Charged Voltage(V)</b>	108
<b>I<sub>mp</sub>(A)</b>	7.35				

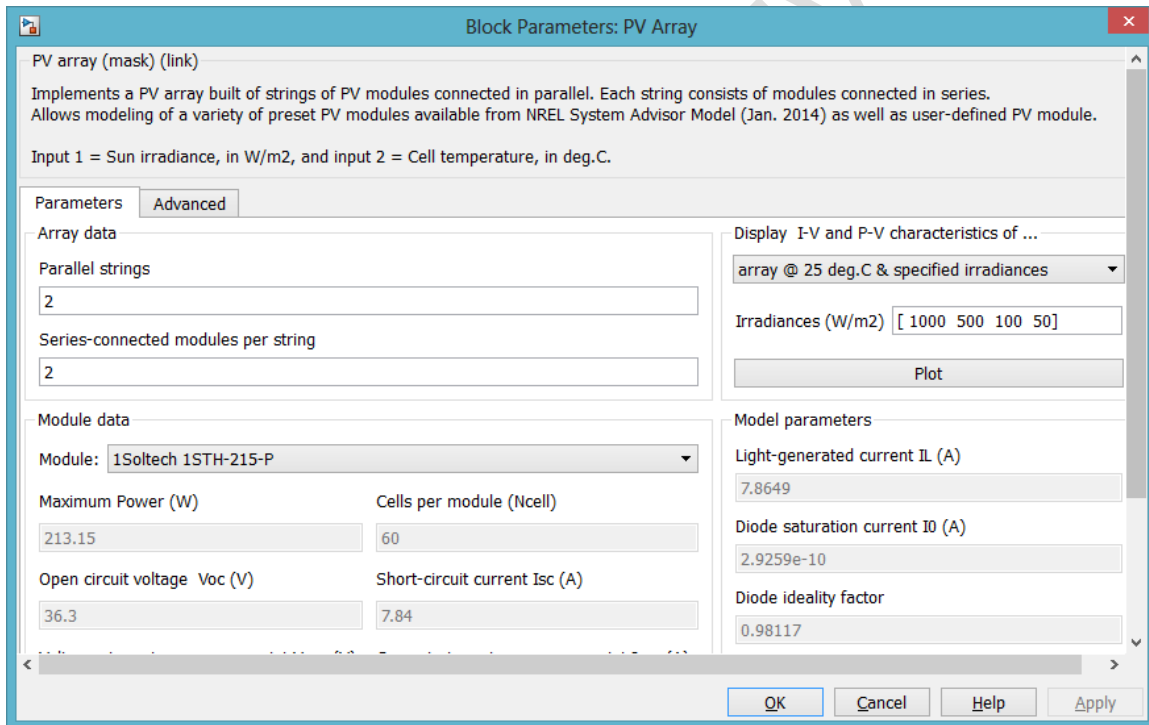
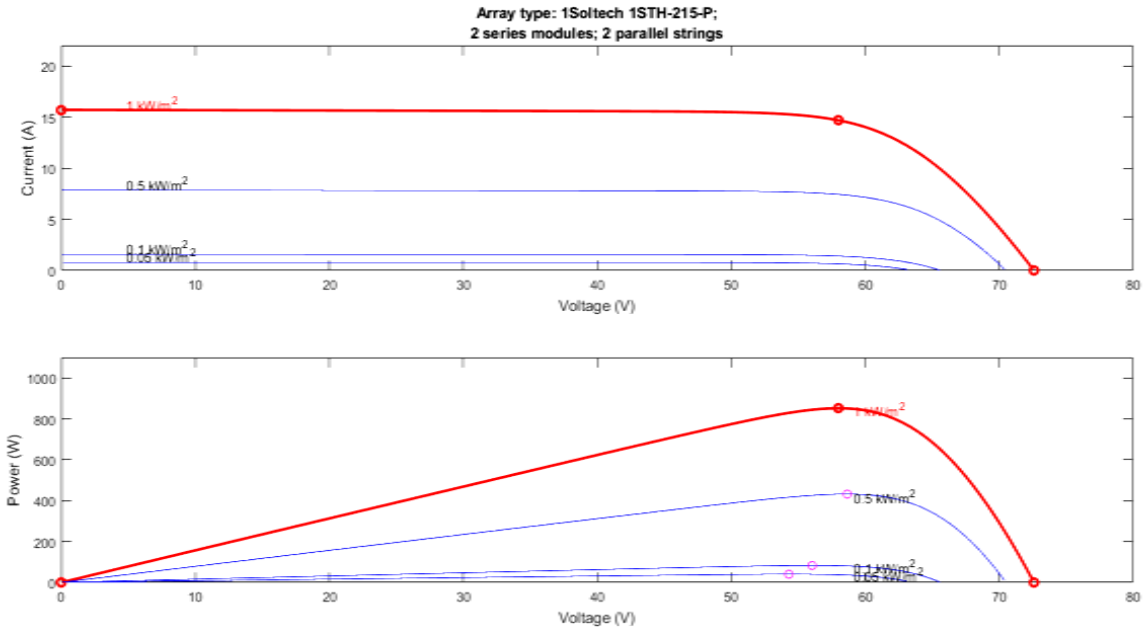
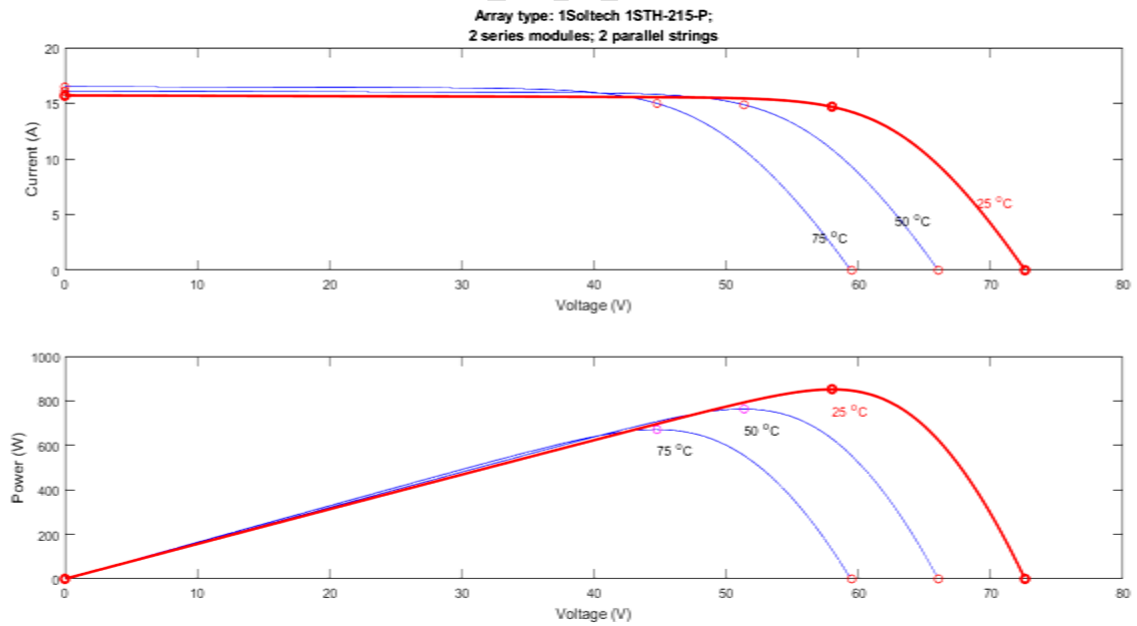

Fig. 2: Design specification for PV module



**Fig. 3: Current and Power variation at different radiation under specific temperature of 25°C**



**Fig. 4: Current and Power variation at different temperatures under specific irradiation of 1000W/m<sup>2</sup>**

## II. FUZZY LOGIC CONTROLLER FOR MAXIMUM POWER POINT TRACKING (MPPT)

The structure of a fuzzy logic controller is rooted in the concept of fuzzy sets, where a variable can belong to one or more sets with a specified degree of membership. The advantages of employing fuzzy logic are manifold: it enables the emulation of human reasoning processes within computers, facilitates the quantification of imprecise information, and enables decision-making based on vague or uncertain information. For instance, it can be used to determine whether a resistive load is connected to the PV module through the buck-boost DC-DC converter [9].

The application of fuzzy logic in MPPT techniques harnesses human expertise and knowledge to construct the controller. Rules can be formulated based on human experience and system performance. In the context of MPPT, a fuzzy logic controller is devised to govern the operation of the buck-boost converter. The fuzzy logic control comprises three essential components: fuzzification, a knowledge base (comprising fuzzy rule sets or a database), and defuzzification (as depicted in Figure 5). The typical sequence involves converting input values into fuzzy representations through the fuzzification process. These fuzzy values then traverse the knowledge base, where decisions are made based on IF-THEN rules, guided by the fuzzy rules. Ultimately, the fuzzy values are transformed into precise, crisp values during defuzzification.

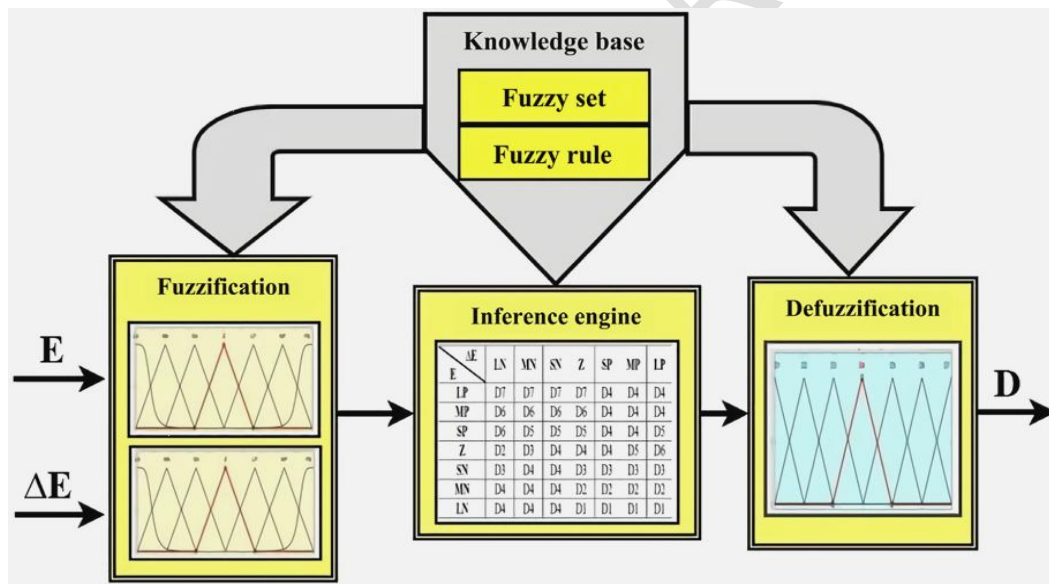
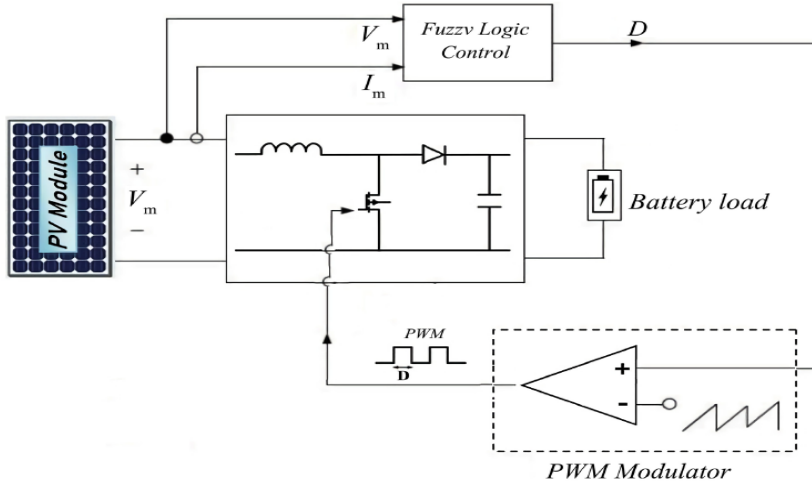

Fig. 5: Description of Fuzzy Logic Control for MPPT [10]

The schematic for the fuzzy logic-based maximum power tracker is depicted in Figure 6 below. As evident, the input parameters for the fuzzy controller comprise the output voltage and current of the PV module, denoted as  $V_m$  and  $I_m$ . The fuzzy logic controller generates a signal that is directly proportional to the duty cycle of the converter, which is then transmitted to the DC-DC converter through the utilization of a pulse width modulator (PWM).



**Fig. 6: Maximum power point tracker using Fuzzy Logic Control**

### III.FUZZIFICATION

This involves the conversion of crisp values to fuzzy values, the actual voltage ( $V$ ) and current ( $I$ ) can be calculated and the power will be derived easily using ( $P = V \times I$ ). Different criteria were constructed based on two input values which include error  $E$  (derived from slope of  $P$ - $I$  curve) and change of error ( $CE$ ). The error ( $E$ ) and change of error ( $CE$ ) can be expressed as

$$E(k) = \frac{P(k) - P(k-1)}{V(k) - V(k-1)}$$

$$DE(k) = E(k) - E(k-1)$$

From the equation,  $P(k)$  and  $I(k)$  represents the power and current of the PV array. The input  $E(k)$  depicts that if the operating point at the sampling instant  $k$  is located on the left or on the right of the MPP on the  $P$ - $I$  characteristic, the input  $DE(k)$  expresses the displacement direction of this operating point, the output  $D(k)$  represents the change in duty cycle of the DC-DC converter. The input variables of the fuzzy controller ( $E$ ,  $DE$ ) are converted to the linguistic variables such as Negative-Big (NB), Negative-Medium (NM), Negative-Small (NS), Zero (ZZ), Positive-Small (PS), Positive-Medium (PM) and Positive-Big (PB) using basic fuzzy subsets. Figure 7 shows the membership functions of the seven (7) basic fuzzy subsets for the respective input and output variables.

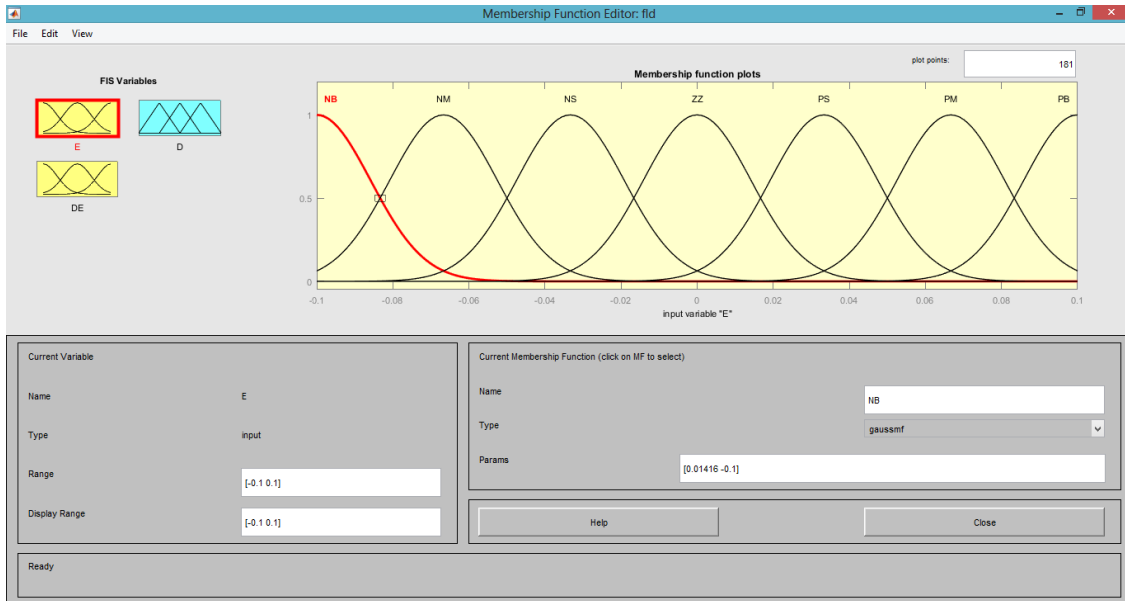

Fig. 7: Membership function for Input Error (E)

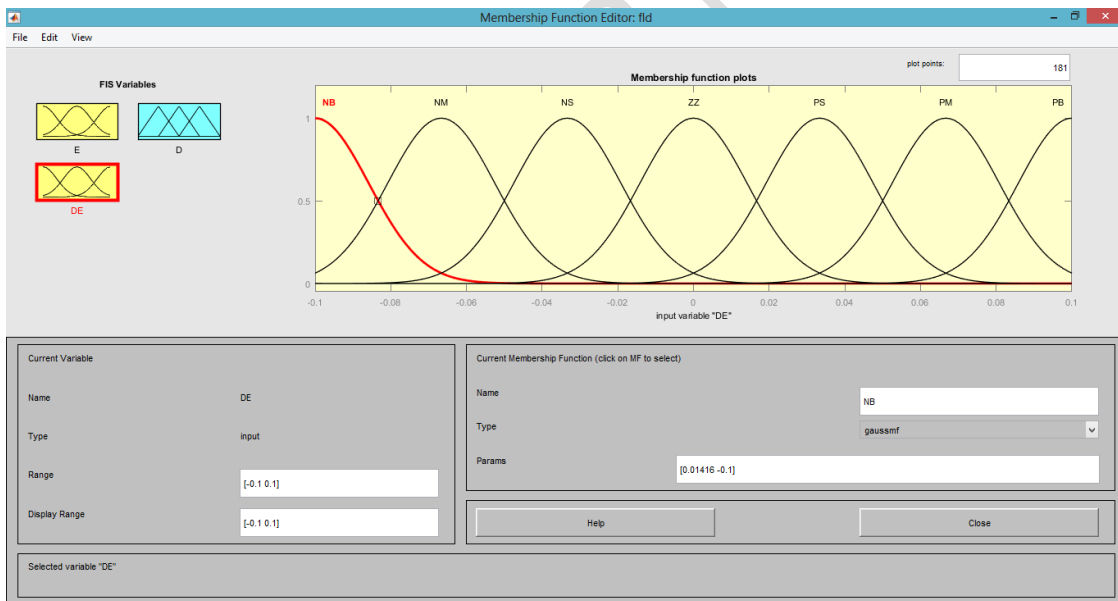
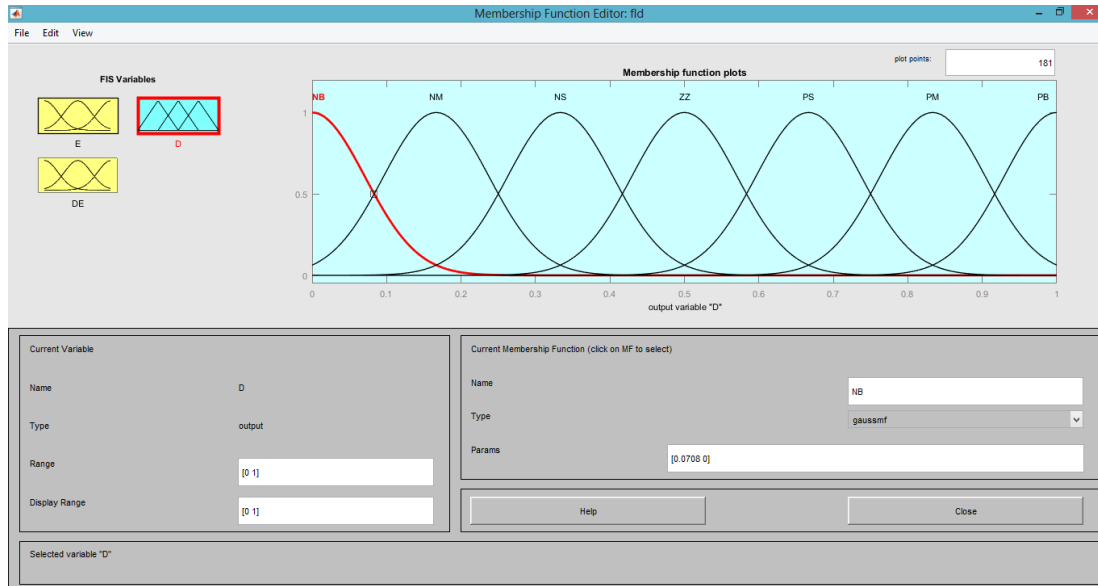

Fig. 8: Membership function for Input Change of Error (DE)



**Fig. 9: Membership function for Output Duty Cycle (D)**

### Fuzzy Inference System (FIS)

The Fuzzy Inference System involves the application of fuzzy rules formulated based on system performance and experience. Fuzzy inputs are generated from crisp values during the fuzzification process; the crisp values were fuzzified to derive the linguistic variables. Table 2 shows the rules of the fuzzy controller for all fuzzy set entries of inputs E (Error) and DE (Change in Error) and output (D) Duty Cycle. A total of 49 (Forty-Nine) rules are presented in Table 2.

**Table 2: Fuzzy Rules for the Charge controller considering Error(E), Change of Error (DE) and Duty Cycle (D)**

		DE						
		NB	NM	NS	ZZ	PS	PM	PB
E	NB	NB	NB	NB	NB	NM	NS	Z
	NM	NB	NB	NB	NM	NS	Z	PS
	NS	NB	NB	NM	NS	Z	PS	PM
	ZZ	NB	NM	NS	Z	PS	PS	PM
	PS	NM	NS	Z	PS	PS	PM	PM
	PM	NS	Z	Z	PS	PM	PM	PB
	PB	Z	Z	PS	PM	PM	PB	PB

The rules expressed in Table 2 can be presented in the form of 3D Surface graph as shown in Figure 10, Figure 11 demonstrates the control rule such as "IF E(Error) is NB(Negative-Big) and DE(change in Error) is PB(Positive- Big), THEN Duty Cycle D is ZZ(Zero)", this implies that if the operating point is far away from the Maximum Power Point(MPP) towards the Left Hand Side and change of slope in P-I characteristics is big in the opposite direction,

then duty cycle is increased. Figure 12 shows the rule viewer, when the red ruler at the input D and DE was moved right and left, the Duty Cycle (D) values increased and decreased according to the set rules inputted into the Fuzzy Inference System (FIS), this shows the effectiveness of the fuzzy logic control.

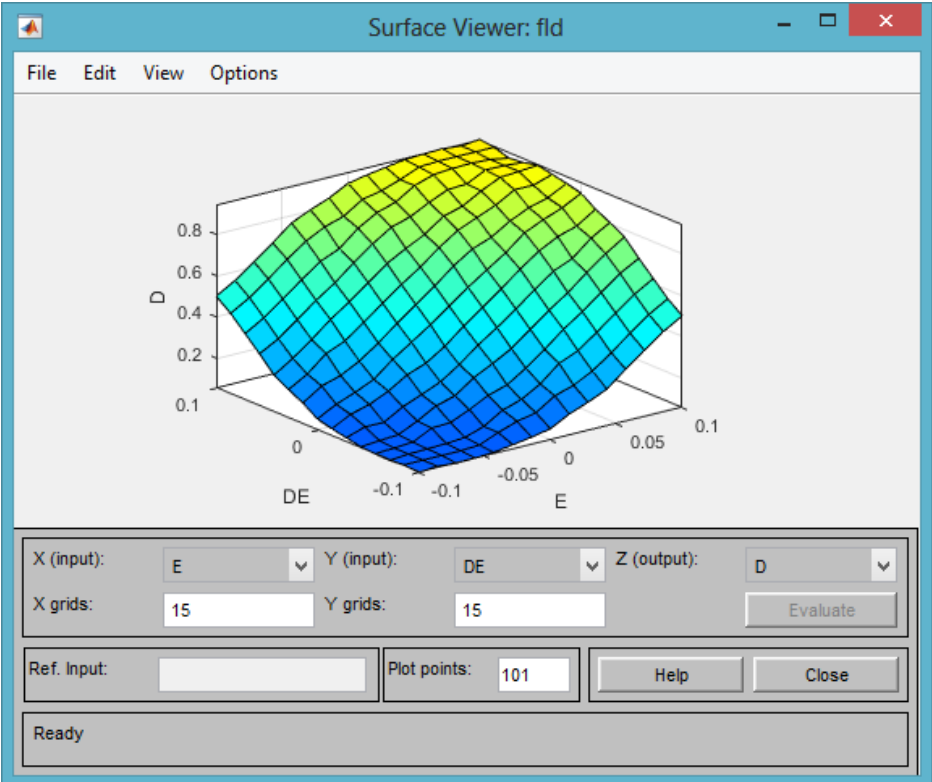

Fig. 10: 3-D Surface Graph for the charge controller

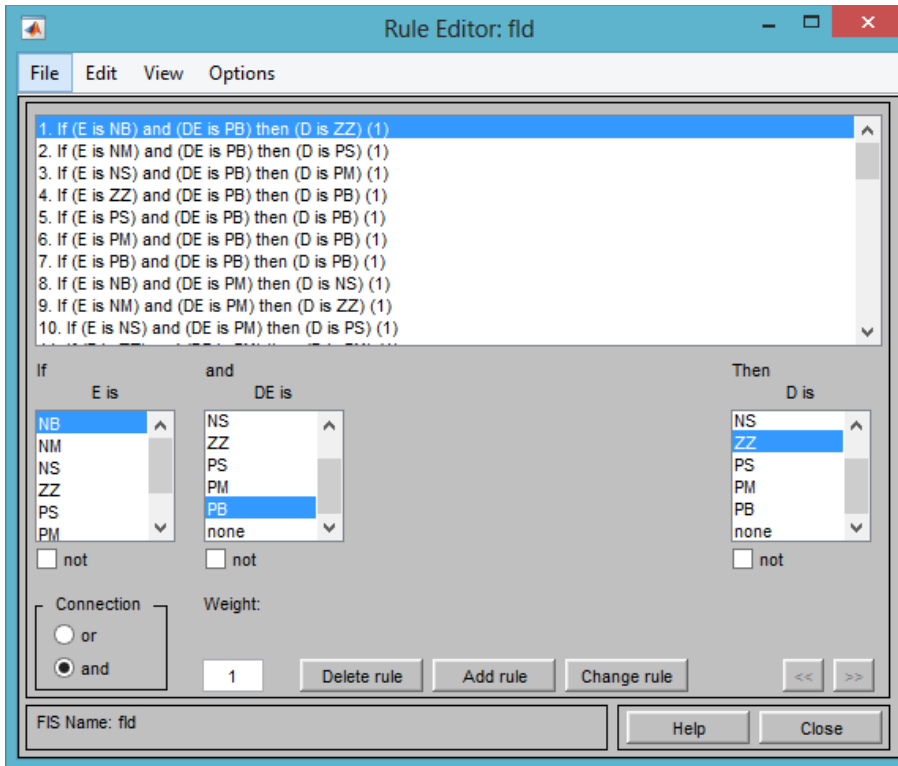

Fig. 11: Rule Editor for the Charge Controller

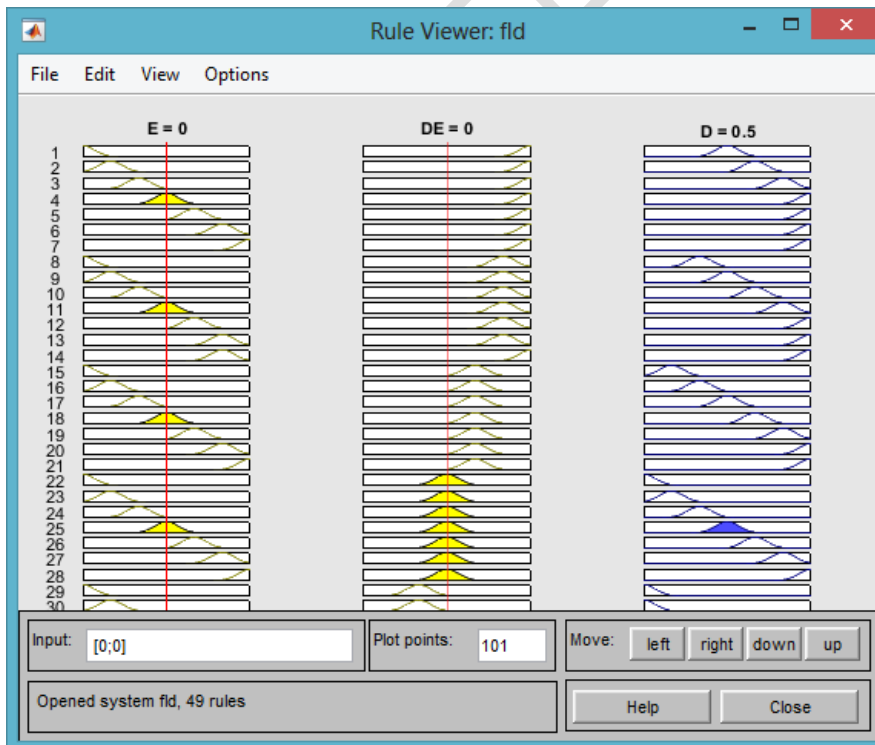

Fig. 12: Rule Viewer for the Charge Controller

## Defuzzification

There is need for fuzzy controller output to be translated from fuzzy values to crisp values because the DC—DC buck boost converter needs the crisp values of Duty Cycle  $D$  received from the PWM at its entry [11], this transformation process is called the Defuzzification. The determination of the centre of gravity (COG) is the most widely used form of Defuzzification. In data representation, the center of gravity is computed by using [12]:

$$D = \frac{\sum_{j=1}^n \mu(\Delta D_j) \cdot \Delta D_j}{\sum_{j=1}^n \mu(\Delta D_j)}$$

where  $D$  is the crisp value output value,  $\Delta D_j$  is the center of max-min composition at the output Membership Functions,  $\mu(\Delta D_j)$  is the maximum of the  $j$ th membership function,  $D_j$  is the  $j$ th input value.

## IV. RESULTS AND DISCUSSION

In this Simulation Model, the design of the fuzzy logic-based MPPT Controller is done under uncertain conditions. The uncertain condition is inputted through the signal builder block in the SIMULINK. The efficiency of the system was evaluated from the results of the simulation. The Model consists of PV array (1Soltech 1STH- 215-P), DC-DC Buck-Boost converter with MPPT controller connected to battery as implemented in matlab/simulink environment (Figure 13). The output of the PV Module is transferred to the connected DC-DC Buck-Boost converter, the Fuzzy Logic Control generated the duty cycle which is transmitted to the PWM (Pulse Width Modulator) that sends information to the DC-DC Buck-Boost converter as shown in the simulink model. The role of controller is to track the maximum power from the PV Module under uncertain conditions. The uncertain conditions can be the change in the temperature and irradiance level.

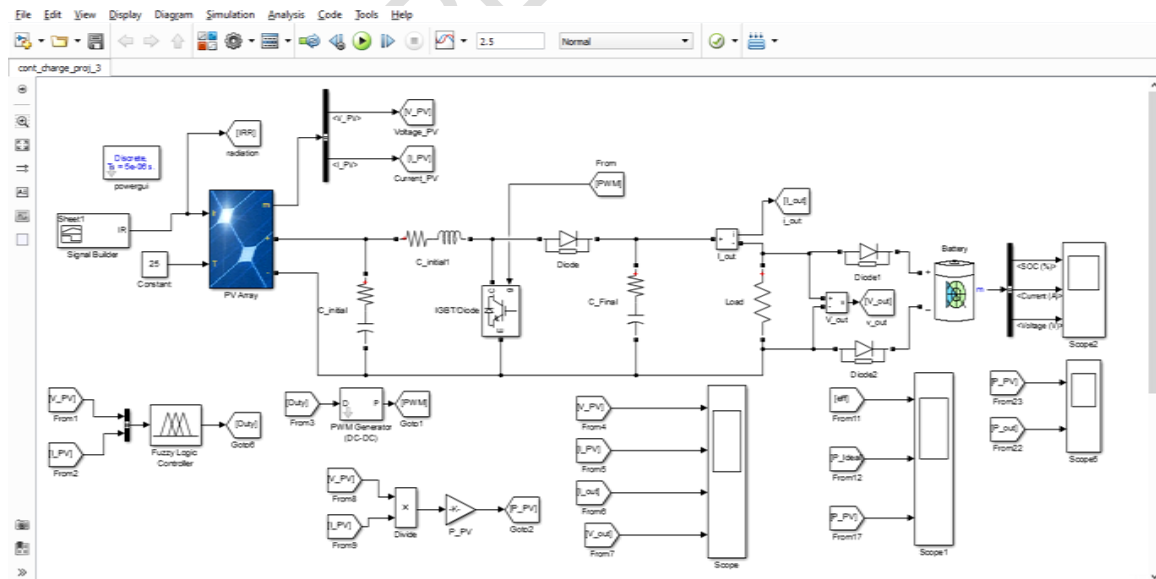

Fig. 13: Complete Simulink Model including the PV Array, Converter and Battery

### Uncertain weather conditions

Signal builder block in the simulink model inputs the uncertain signal to the PV module, the uncertain conditions includes different weather conditions that can affect the performance of charge controller. The irradiance level distribution is shown in Figure 14, solar radiation continuously changes within a time sequence, the maximum irradiance noticed is approximately  $600\text{W/m}^2$  which occurs during the noon of the day.

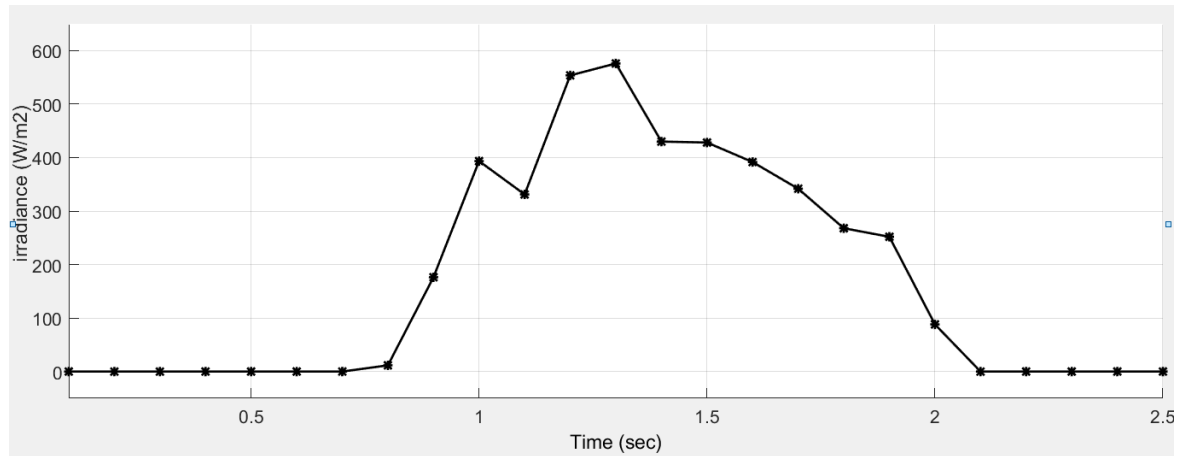

Fig. 14: Solar radiation distribution profile

Figure 15 shows the relationship between the ideal PV power and the generated PV power, the PV power generated shows similar trend with the ideal PV power, the peak value of PV power is about 400Watt which is close to the peak ideal power of 500Watt, the power changes from about 0 to 400Watt, the efficiency of the fuzzy MPPT charge controller is approximately 80%, the PV voltage generated by the fuzzy logic control is consistent with the solar radiation as shown in Figure 15. Figure 16 and 17 shows that the converter reduced the PV current and increased the PV voltage based on the fuzzy rules, this is to avoid battery overcharging or undercharging.

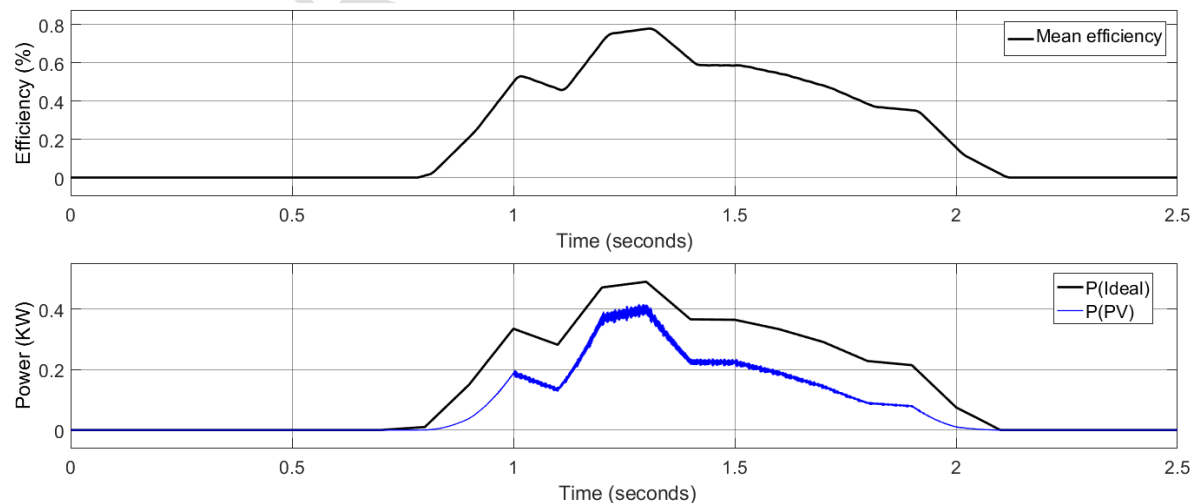
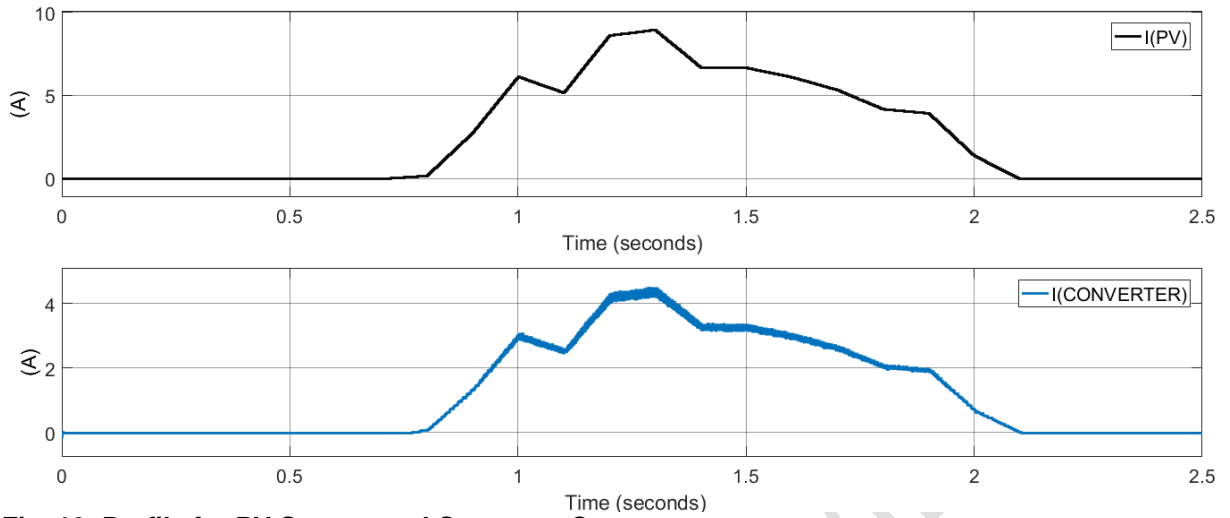
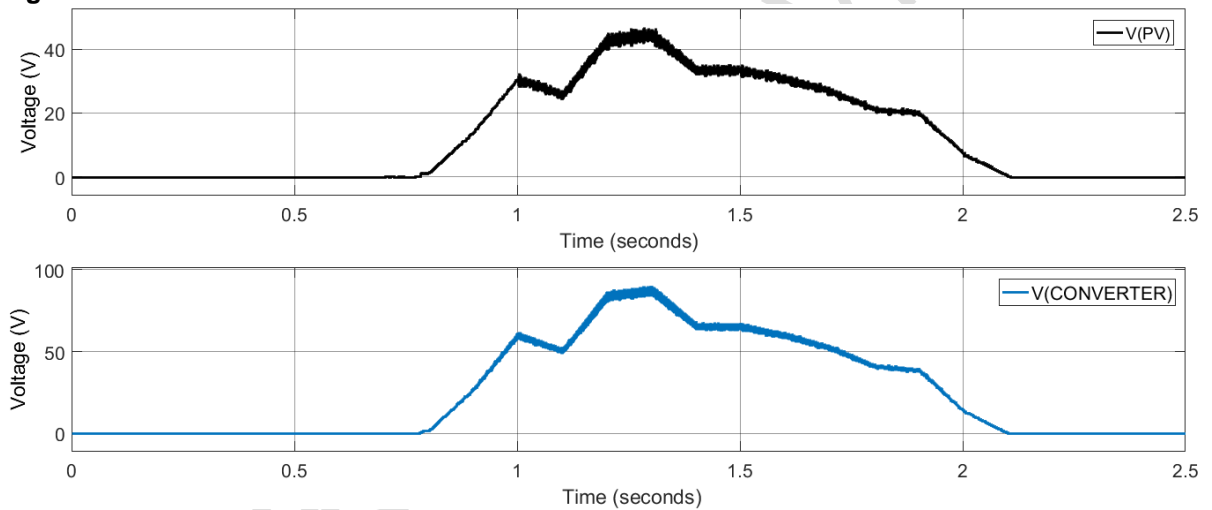

Fig. 15: Efficiency and PV Power Profile



**Fig. 16: Profile for PV Current and Converter Current**



**Fig. 17: Profile for PV Voltage and Converter Voltage**

## V. CONCLUSION

When the uncertain weather conditions are varied, the PV module was able to attain a maximum power point (MPP). In this research work, fuzzy logic based MPPT charge controller was able to regulate the voltage and current without overcharging or undercharging the battery, the fuzzy logic charge controller was simulated using matlab/simulink shows that the performance of charge controller can be improved by incorporating fuzzy logic into its operations.

## REFERENCES

- [1] V. Ashita, K. M. Dharmendra, P. Amit, J. S. Geetika, "Simulation, Design and Analysis of Different Types of Solar Based Charge Controllers on MATLAB/Simulink," *International Journal of Engineering Research and Technology*, ISSN 0974-3154, 14:180 -197, 2021
- [2] L. K. Narwat, J. Dhillon, "Design and Operation of Fuzzy Logic Based MPPT Controller under Uncertain Condition," *Journal of Physics: Conference Series*, 1854, 2021, doi:10.1088/1742-6596/1854/1/012035
- [3] J. Adeeb, A. Farhan, A. Al-Salaymeh, "Temperature Effect on Performance of Different Solar Cell Technologies," *J. Ecol. Eng.*, vol. 20, no. 5, pp. 249–254, 2019.
- [4] M. Rokonuzzaman, M. Shakeri, F. A. Hamid, M. K. Mishu, J. Pasupuleti, K. S. Rahman, S. K. Tiong and Nowshad Amin, "IoT-Enabled High Efficiency Smart Solar Charge Controller with Maximum Power Point Tracking—Design, Hardware Implementation and Performance Testing," *Electronics*, 2020, 9, 1267; doi:10.3390/electronics9081267
- [5] S. D. Surendra, S. Ruchi, P. Raghavendra, "Using Improved MPPT Charge Controller Improvement Functioning Efficiency of Power Grid Connected Solar Photovoltaic System," *IOP Conf. Series: Materials Science and Engineering*, 1099 (2021), 012083doi:10.1088/1757-899X/1099/1/012083
- [6] B. Bendib, F. Krim, H. Belmili, M. F. Almi, S. Boulouma, "Advanced Fuzzy MPPT Controller for a stand-alone PV system," *The International Conference on Technologies and Materials for Renewable Energy, Environment and Sustainability*, *Energy Procedia*, 50 (2014), 383-392
- [7] M. Veerachary, "Power tracking for nonlinear PV sources with coupled inductor SEPIC converter," *IEEE transactions on aerospace and electronic systems*, 41: 3 (2005): 1019- 1029.
- [8] I. H. Altas, A. M. Sharaf, "A photovoltaic array simulation model for matlab-simulink GUI environment," *Clean Electrical Power, 2007. ICCEP'07. International Conference on*. IEEE, 2007.
- [9] I. A. Samuel, O. Izi, T. E. Somefun, A. A. Awelewa, J. Katende, "Design and performance analysis of a charge controller for solar system using MATLAB/SIMULINK," *Front. Energy Res.* 10:1017017, 2022, doi: 10.3389/fenrg.2022.1017017

[10] M. Y. Baramadeh, M. A. A. Abouelela, S. M. Alghuwainem, "Maximum Power Point Tracker Controller Using Fuzzy Logic Control with Battery Load for Photovoltaics Systems," *Smart Grid and Renewable Energy*, 12:163-181, 2021, <https://doi.org/10.4236/sgre.2021.1210010>

[11] A. O Baba, G. Liu, X, Chen "Classification and Evaluation Review of Maximum Power Point Tracking Methods," *Sustainable Futures*, 2:100020, 2020. <https://doi.org/10.1016/j.sftr.2020.100020>

[12] A. E. Khateb, N. A. Rahim, J. Selvaraj, M. N. Uddin, "Fuzzy-logic controller-based SEPIC converter for maximum power point tracking," *IEEE Trans Industry Appl*, 2014; 50(4):2349e58.

UNDER PEER REVIEW