

Design and Development of an Android-Based Remote Cardiac Monitoring Device for Continuous Real-time ECG Signal Acquisition, Transmission, and Analysis.

Abstract

Cardiovascular diseases (CVDs) are a leading cause of mortality worldwide, necessitating innovative solutions for early detection and continuous monitoring. This research aims to develop an Android-based remote cardiac monitoring device for real-time electrocardiogram (ECG) signal acquisition, transmission, and analysis. The system comprises hardware for acquiring ECG signals, algorithms for processing and machine learning models for anomaly classification. The hardware unit captures ECG data using electrodes and sensors. The signals are filtered, processed, and transmitted to the cloud infrastructure enabling real-time monitoring and analysis. Machine learning models including support vector machines, ensemble methods and Artificial neural networks are trained on ECG datasets to classify signals and detect cardiac abnormalities. Comprehensive testing validates the system's capabilities in real-time signal acquisition, processing, anomaly detection and data transmission. The integration of hardware, algorithms and machine learning enables round-the-clock monitoring of cardiac activity, facilitating prompt interventions and improved patient outcomes. This affordable and user-friendly system demonstrates potential for enhanced accessibility and effectiveness of preventive cardiac care.

Keywords: remote cardiac monitoring, ECG, Android, machine learning, cardiovascular diseases

1.0 INTRODUCTION

The background of the study revolves around the global prevalence of cardiovascular diseases (CVDs) as the leading cause of mortality, affecting millions of lives annually. Despite being a significant concern across all nations, the burden of CVDs extends particularly to low- and middle-income countries due to various factors like lifestyle changes, urbanization, and an aging population (Owolabi et al 2016). This not only poses a threat to public health but also imposes substantial economic strains on healthcare systems worldwide (Afoakwa et al 2021). Traditional cardiac monitoring methods have limitations, including intermittent measurements and bulky equipment, which hinder their efficacy in detecting cardiac abnormalities. These limitations underscore the necessity for innovative solutions capable of real-time data capture and continuous monitoring (Lee et al 2017). Leveraging Android-based technology presents a promising avenue for developing portable, user-friendly cardiac monitoring devices that transcend traditional healthcare settings (Mena et al 2018). The advancement of Android technology enables the creation of mobile health (mHealth) solutions, telemedicine platforms, and medical education tools. This technology supports remote patient monitoring, teleconsultations, health data management, and behavior tracking, offering opportunities to revolutionize accessibility and convenience in cardiac care (McConnel et al 2018).

The justification of the research lies in addressing the pressing need for innovative solutions in cardiac monitoring by harnessing Android-based technology. The proposed research aims to design and develop an Android-based remote cardiac

monitoring device capable of acquiring and transmitting ECG signals in real-time. Additionally, machine learning algorithms will be trained and validated to perform real-time analysis and prediction of cardiac anomalies using the acquired ECG signals. The accuracy and reliability of the developed device and machine learning algorithms in detecting and predicting cardiac anomalies will be evaluated. Overall, the research aims to bridge the gap between traditional monitoring methods and modern technological advancements to revolutionize cardiac care accessibility, efficiency, and effectiveness. By democratizing cardiac care and empowering individuals to monitor their cardiovascular health conveniently and proactively, the research seeks to contribute to the prevention and management of cardiovascular diseases on a global scale.

2.0 LITERATURE REVIEW

Online telemedicine systems, leveraging wireless and wearable sensor technologies, offer efficient healthcare services (Kakria et al., 2015). This study presents the development and evaluation of a real-time heart monitoring system addressing cost, application ease, accuracy, and data security. It acts as a bridge between doctors and patients, crucial for remote healthcare (Kakria et al., 2015). Evaluation on 40 individuals demonstrates the system's reliability, high-speed performance, and robust data security at low cost (Kakria et al., 2015). Future research should focus on long-term usability, scalability, and integration with existing healthcare infrastructure, along with user experience and acceptance, to ensure widespread adoption in remote healthcare settings (Kakria et al., 2015).

The study by Wahane et al., (2016) introduces an ARM7 microcontroller-based

health monitoring system, leveraging Wireless Body Area Networks (WBANs) and Wireless Sensor Networks (WSNs), to detect abnormal heart rates and blood oxygen levels. Integrated with ECG as a non-invasive diagnostic tool, the system alerts patients to potential health issues, transmitting data via Bluetooth and Android platforms to a Medical Server for remote visualization by doctors. Experimental results validate the system's compactness, affordability, user-friendliness, and effectiveness in proactive healthcare management.

Bertogna et al. (2020) contribute to biomedical engineering by focusing on long-term electrocardiographic (ECG) monitoring, emphasizing efficient transmission of compressed ECG signals over the internet. Challenges like synchronization and limited bandwidth are addressed with innovative solutions, including cloud storage. Their ECG system leverages Mobile Cloud Computing (MCC) for storage services and signal compression, optimizing processing power usage and internet transmission. Using vector quantization for compression, the system shows promising performance in remote ECG monitoring, preserving morphological information while achieving good compression rates and minimal bandwidth requirements. These concepts hold potential for enhancing telemedicine systems and remote patient monitoring.

Al-Mariachi (2020) introduces a novel approach to securely accessing clinical data while outlining future advancements in clinical systems. The research centers on developing a reliable and cost-effective wireless remote monitoring system for patients. Physiological parameters are recorded via wireless sensor networks (WSNs), with hubs communicating remotely to an Android smartphone through Bluetooth or Wi-Fi networks. Data, including temperature, blood pressure, and heartbeat

readings, are transmitted to the hospital's specialist server. Wearable medical sensors and an Android-based app facilitate data storage and real-time monitoring. An alert mechanism notifies doctors of abnormal conditions, allowing wireless access to patient medical information via Wi-Fi and cellular systems. A private cloud-based environment validates patient health data, enabling continuous monitoring within medical centers and beyond, ensuring round-the-clock patient health information surveillance.

Mohammed et al. (2020) offers a valuable contribution by addressing the lack of standardization in ECG monitoring systems through a comprehensive review and proposed taxonomy. Their work provides a foundational framework for future research and development by establishing a clear classification system and suggesting a generic architectural model. Additionally, acknowledging the potential of integrating advanced technologies like AI and Big Data paves the way for more sophisticated and interconnected future monitoring systems.

Remote monitoring has become a vital focus in healthcare research, especially outside clinical settings, driven by rapid technological advancements. Benjaman et al. (2020) propose a Remote Heart Monitoring System (RHMS) integrating machine learning and visual analytics for real-time data analysis in cases involving Remote Cardiac Patients. Their multi-agent architecture ensures system quality and development success. Evaluated by 30 participants, the prototype showcases feasibility, utility, and usability, with promising results in real-time monitoring and out-of-hospital data management. This approach offers insights into future e-Health systems, leveraging IoT techniques to revolutionize healthcare delivery.

Christ et al. (2020) elucidate an IoT-controlled remote monitoring system utilizing Raspberry Pi, a credit card-sized single-board computer with an ARM11 microprocessor. The system continuously monitors Electrocardiogram (ECG) and other vital parameters, storing measured data in a database accessible only by authorized personnel such as physicians and caretakers. The primary objective is to update the database with real-time data and alert physicians to any anomalies. Integration with the MySQLdb module facilitates Raspberry Pi's connection to the database, while alert messages are dispatched through the combined efforts of Raspberry Pi and a GSM module. The system holds significant potential for scientific research within the medical community, as the gathered data can inform studies on arrhythmia patterns and aid in predicting their nature. The paper emphasizes system design and the underlying algorithm necessary for task accomplishment, laying groundwork for future advancements and applications in remote healthcare monitoring.

Umar et al. (2021) introduce an innovative IoT-based Cardiac Healthcare System, aiming to transform traditional healthcare methods. Critiquing long wait times, high costs, and manual processes in traditional healthcare, they propose a Smart Cardiac Care System for continuous patient monitoring. This system ensures affordability, accuracy, and real-time observations while prioritizing patient privacy and minimizing physical examinations. By sampling multiple physical signs and conducting ECG analysis, it offers unique insights into cardiac health. Alerts for abnormal values and cloud-based patient records ensure widespread accessibility. This pioneering approach promises comprehensive cardiac care through IoT

technology, marking a significant advancement in healthcare delivery.

Roy et al. (2021) proposes the Internet of Things (IoT) as a transformative force in healthcare, enhancing quality of life and reducing mortality rates. Their project aims to develop a Proof-of-Concept prototype for a Connected Healthcare multisensory IoT system, focusing on early detection of cardiac arrest. Prioritizing cost-effectiveness, the design integrates various sensors and data collection software to ensure accessibility. This endeavor showcases IoT's potential in revolutionizing healthcare by enabling proactive monitoring and early intervention, ultimately improving patient outcomes.

Singh et al. (2021) showcase the potential of wireless sensors and mobile technology for real-time ECG monitoring, offering a lightweight, wearable, and affordable solution for patients with chronic heart conditions. Their study demonstrates high accuracy in ECG signal visualization, validated against a commercial ECG machine. This approach holds promise for remote healthcare applications, enhancing self-recognition and monitoring capabilities. Meanwhile, Sahu et al. (2021) introduce an IoT-enabled real-time ECG monitoring system leveraging cloud computing, facilitating remote CVD monitoring with reliable data transmission and analysis. These innovations signify significant strides in remote healthcare, warranting further exploration of long-term usability, scalability, and user acceptance for widespread adoption.

Bazi et al. (2021) present an innovative ECG system for simultaneous remote monitoring of multiple heart patients. Comprising patient, server, and monitoring units, the system integrates wearable sensors, mobile technology, and internet connectivity. ECG signals are captured by

miniature sensors, transmitted to smartphones, and forwarded to a centralized server. Healthcare professionals' access and analyze data in real-time for comprehensive cardiac health assessment and timely intervention. This system promises to revolutionize remote cardiac monitoring, offering efficient surveillance and management capabilities. Future research should address scalability, interoperability, and user acceptance for widespread adoption in clinical practice.

Ahmed et al. (2022) highlight the pivotal role of electrocardiogram (ECG) monitoring in detecting cardiac arrhythmias early and preventing complications. They introduce a mobile application paired with a sensor unit for real-time cardiac signal monitoring. The device, featuring 3-lead EKG patches with integrated Bluetooth, enables seamless connectivity with smartphones. It can be affixed to humanoid robot arm fingers or used independently with a wearable patch on the chest. Real-time EKG signals are displayed on the Android application, exhibiting clear P, QRS, and T waves. Tested with the ProSim8 ECG simulator, the device demonstrates signal quality. This cost-effective telemedicine solution offers cardiac home care assistance in remote areas, potentially reducing clinical procedure times.

Gonzalez-Fernandez et al. (2022) propose three cost-effective approaches to cardiac care utilizing public data networks. The first involves daily ECG recordings for arrhythmic patients, fostering a closer patient-physician relationship and enabling detailed analysis without clinic visits. The second approach introduces a 24-hour portable device for high-risk patients, detecting cardiac events and falls, with urgent messages sent to relatives and emergency services. The third system enables periodic twelve-lead ECG recordings for individuals with heart

disease, facilitating early detection of cardiac disturbances through trend analysis. These approaches aim to improve patient outcomes and provide efficient solutions for low-budget public health systems.

Noorwali et al. (2022) tackle the urgent need for early detection and treatment of fetal cardiac abnormalities through continuous fetal health monitoring during pregnancy. Their study designs a non-invasive fetal electrocardiogram (fECG) monitoring system, leveraging computer science and sensor technology advancements. Phase one involves real-time signal transmission via WiFi and signal analysis on a Raspberry Pi 3. Phase two introduces a method for extracting fetal electrocardiogram (fECG) using Independent Component Analysis (ICA) and Wavelet Transform (WT) to overcome noise sources. Validation with real data from the Physionet database confirms the method's effectiveness. The study proposes a portable fECG monitoring system, promising improved prenatal care through non-invasive fetal cardiac monitoring.

Mohamed et al. (2023) emphasize the importance of continuous cardiovascular monitoring for postoperative patients in critical care settings. While existing devices focus on auscultating heart and lung sounds, they lack continuous display and monitoring of derived cardiopulmonary parameters. Addressing this gap, Mohamed et al. (2023) introduce a bedside monitoring system with a lightweight, wearable patch sensor. Heart and lung sounds are collected via a chest stethoscope and microphones, with noise cancellation algorithms to remove background noise. Short-distance ECG signals are acquired using electrodes and processed in real-time. A tablet-based software displays acquired waveforms and processed cardiovascular parameters, allowing seamless integration of auscultation and ECG signal acquisition.

The system's wearability and lightweight design ensure patient comfort, making it a promising tool for continuous cardiovascular monitoring in healthcare settings.

Tambe et al. (2023) introduce an IoT-based ICU Monitoring System for real-time updates on critical patients' health parameters in intensive care units (ICUs). Leveraging Arduino technology, the system automates data collection using body or environmental sensors, crucial for continuous monitoring in ICUs. It facilitates rapid communication, early emergency identification, and proactive treatment initiation, minimizing errors and delays. The system, utilizing various sensors and mobile applications, transmits data to an IoT server via Arduino Uno Controller. In emergencies, data is promptly sent to attending doctors, enhancing ICU patient care with real-time updates on oxygen levels, ECG, temperature, humidity, and blood pressure. Smart ICUs improve monitoring for critically ill patients.

3.0 METHODOLOGY

3.1 THE SYSTEM ARCHITECTURE

The research architecture comprises three main components: data acquisition, signal processing and analysis, and machine learning-based classification. The data acquisition component consists of a hardware device designed to acquire ECG signals and other vitals from the human body. The device comprises sensors and electrodes that are placed on the body to measure the electrical activity of the heart. The signals are then amplified and filtered to remove noise and artifacts (figure 1). The signal processing and analysis component involves the use of digital signal processing techniques to preprocess the ECG signals. This includes filtering, baseline removal, and feature extraction. The filtered signals are segmented into individual heartbeats, and a set of features is extracted from each

beat. The extracted features are then used as inputs to the machine learning-based classification component. The machine learning-based classification component consists of support vector machine, Ensemble and Artificial neural network model was used to trained and classify the ECG signals into different categories of cardiac anomalies. The machine learning model is trained using a large dataset of ECG signals with known labels. The model is trained using all the machine learning models, and the performance is evaluated using standard metrics such as accuracy, precision, recall, and F1-score.

The architecture also includes a cloud-based infrastructure for remote monitoring and management of the ECG signals. The cloud infrastructure enables the transmission of ECG signals to a remote server for storage and analysis. This allows for real-time monitoring of the ECG signals by medical professionals, who can remotely diagnose and treat cardiac anomalies based on the prediction uploaded on the mobile device.

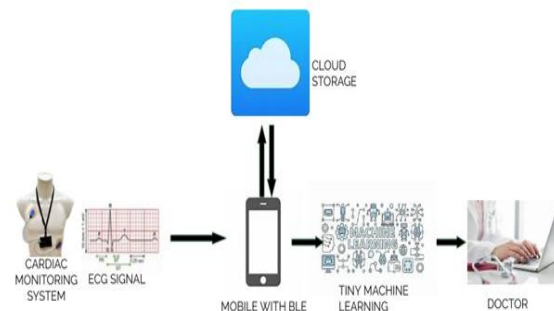

Figure1: Android-Based Remote Cardiac Monitoring system model

3.2 Engineering Design Analysis

The design methodology underpinning the creation of an Android-Based Remote Cardiac Monitoring Device revolves around strategic choices and meticulous

implementation. The utilization of a bridge rectifier stands out as a pivotal advantage, enabling independence from a center-tap on the transformer's secondary side. This design characteristic, coupled with a ripple frequency at the output twice the line frequency (50 Hz), streamlines the filtering process, ensuring efficient signal conditioning. In determining the transformer's rating, meticulous attention was paid to the required output voltage and current, meticulously set at 12-13V and 500mA, respectively. Despite the predominantly DC output of the rectifier, the challenge of unwanted noise resembling an AC signal persisted due to diode-induced ripples. To address this, a 25V, 1000uF electrolytic capacitor was strategically integrated in parallel to the rectifier output, effectively filtering the AC component. Furthermore, to guarantee a stable 5-volt supply, the integration of a voltage regulator IC, specifically the LM7805, was paramount. This regulator ensures consistent output voltage, furnishing a reliable power source critical for the functionality of digital logic circuits and processors inherent in the system's architecture. The meticulously crafted power circuit design ultimately ensures a smooth, regulated power supply indispensable for the seamless operation of the health monitoring system.

The microcontroller unit serves as the central nervous system of the device, anchored by the Arduino UNO microcontroller. Programmed to receive signals from various sensors, the Arduino UNO utilizes the Arduino C programmer, leveraging its array of 14 pins on each side for versatile interfacing capabilities. Equipped with sets of digital and analog input/output (I/O) pins, including 14 digital I/O pins (six PWM capable) and 6 analog I/O pins, the Arduino UNO board is a cornerstone of the system. Programmed via the Arduino IDE using a type B USB 2.0

cable, each pin is meticulously assigned to execute specific tasks, ensuring seamless coordination and processing of vital data from sensors.

Advanced sensor technology, exemplified by the MAX30102 sensor module, underscores the device's efficacy in real-time cardiac monitoring. Leveraging photoplethysmography (PPG) to measure heart rate and blood oxygen levels, this module emits infrared and red light into the skin, capturing variations in light absorption or reflection during each heartbeat. Similarly, the AD8232 integrated circuit enhances electrocardiogram (ECG) measurements, employing an instrumentation amplifier to amplify weak ECG signals while suppressing noise. The right-leg drive circuit and lead-off detection mechanisms further enhance signal fidelity, facilitating accurate ECG readings critical for medical diagnosis.

The display unit, featuring a 16x2 Character LCD Display equipped with an I2C adapter, assumes a pivotal role in conveying vital information to users. Employing a dot matrix module, this display effectively communicates letters, numbers, and characters in a user-friendly format. Integrated with the I2C serial bus, the LCD display operates seamlessly with standard voltages of 5V and 3.3V, streamlining connectivity via VCC, GND, SDA, and SCL pins. The GSM module and SIM card, constituting the transmission unit, serve as the linchpin for data dissemination (figure 2). Facilitating the transmission of signals and measured vital signs data to the designated database, these components ensure real-time monitoring and analysis. The power supply, derived from a 120V AC source and regulated using the LM7805 voltage regulator, is meticulously engineered to provide the requisite 5V DC for the circuit's operation. Leveraging the LM2596S buck converter to power the GSM module, the

system embodies a holistic approach to power management, ensuring seamless integration and operational integrity. The physical implementation, executed on a Vero board using surface-mounted components and soldering techniques, underscores meticulous attention to detail and functional coherence, culminating in the realization of a robust, Android-Based Remote Cardiac Monitoring Device.

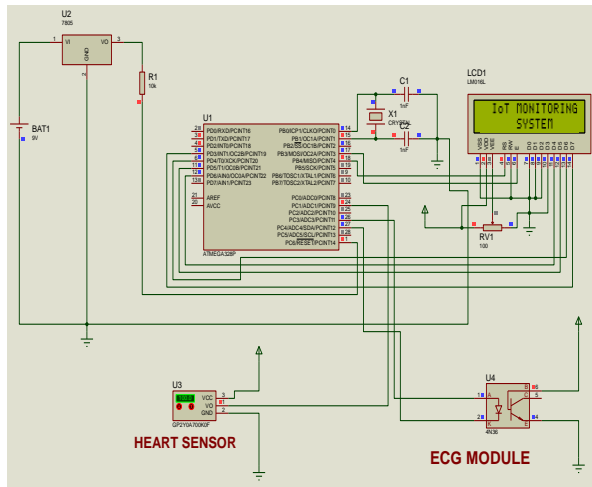

Figure2: Circuitry arrangement of the hardware device components

3.3 Mode of Operation of the System

The design and development of an Android-Based Remote Cardiac Monitoring Device for Continuous Real-time ECG Signal Acquisition, Transmission, and Analysis integrates cutting-edge features to ensure comprehensive health monitoring. When the ECG module captures heart electrical activity, it sends a signal to the microcontroller, triggering the microprocessor to upload the data to the server. Arduino Uno assumes a pivotal role as the central microprocessor, interfacing seamlessly with both an ECG module and a MAX30102 sensor. The ECG module interfaces with the Arduino's Analog-to-Digital Converter (ADC), while the MAX30102 sensor communicates via the I2C protocol (figure 3). The Arduino program,

crafted in the Arduino IDE using C++, efficiently processes real-time data from both sensors.

Furthermore, the system achieves a secure connection with a MySQL database, facilitating the storage of ECG and MAX30102 sensor readings. The SQL database schema is meticulously designed to accommodate timestamped health data, providing a structured storage solution conducive to efficient data retrieval and analysis. To bolster data security, HTTPS communication is implemented between the Arduino and the SQL database, ensuring the integrity and confidentiality of transmitted information.

Through rigorous testing and calibration phases, the system attains accurate sensor readings, guaranteeing reliability and precision in health data acquisition. Additionally, a dedicated web or mobile application is developed to enable remote monitoring of stored health data, empowering users with real-time access to vital health metrics and trends. Importantly, the completed project adheres to stringent regulatory standards for medical devices, ensuring compliance and facilitating its seamless deployment in real-world healthcare environments.

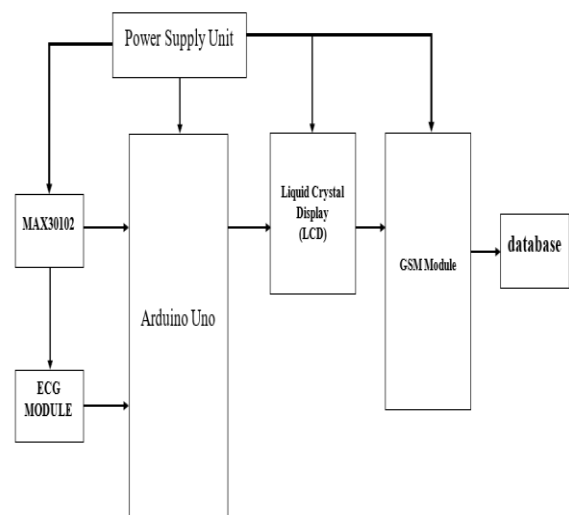

Figure3: The developed cardiac monitoring device block diagram model

3.4 Software design analysis

The software design for the project titled "Design and Development of an Android-Based Remote Cardiac Monitoring Device for Continuous Real-time ECG Signal Acquisition, Transmission, and Analysis" was executed using a specific version of the C compiler tailored for the Arduino microchip, ensuring compatibility and efficient code execution. The compiler encompasses an optimized C compiler program along with enhanced functions for various microcontroller operations, contributing to the reliability and performance of the device.

The algorithm's implementation within the Arduino microcontroller programming incorporates key functionalities for ECG signal processing and transmission. These functionalities include signal filtering to remove noise, real-time analysis for detecting abnormalities, and compression techniques to optimize data transmission bandwidth, ensuring timely and accurate monitoring of cardiac activity. For data transmission, a robust communication protocol is employed to facilitate seamless interaction between the monitoring device and the Android-based application. In this project, Bluetooth technology is utilized for its widespread compatibility and low power consumption, enabling continuous real-time transmission of ECG data to the designated mobile device for analysis and storage.

In consideration of data security, stringent measures are implemented to safeguard the confidentiality and integrity of transmitted and stored information. Advanced encryption protocols are employed to secure the communication channel between the monitoring device and the Android application, preventing unauthorized access or tampering of sensitive patient data.

Additionally, secure storage mechanisms are implemented within the application to ensure compliance with privacy regulations and mitigate potential risks associated with data breaches.

3.5 Hardware Performance Testing and Validation

The integrated prototype of the IoT-based health monitoring system underwent a rigorous hardware performance testing regime to verify its functionality, reliability, and data integrity. This multi-stage process ensured the system's effectiveness in capturing and analyzing vital health data for improved patient care and monitoring.

Simulation Testing: Prior to physical construction, the system design was thoroughly evaluated using Proteus software. This virtual environment enabled comprehensive assessment, including circuit performance, error detection, and rectification. The software facilitated the identification of potential design flaws, signal integrity issues, and component compatibility concerns, ensuring robust hardware design.

Component and System Testing: Following construction, each individual component underwent meticulous testing to verify functionality and integration within the system. Key parameters were measured and compared against predetermined specifications, ensuring seamless communication and data exchange between components.

Sensory Circuitry Evaluation: The sensory circuitry responsible for capturing vital signs underwent rigorous testing to assess sensitivity levels and validate performance across various physiological ranges.

Real-World System Validation: The fully assembled system was tested in a controlled environment replicating real-world conditions. This involved functional assessment and evaluation of data acquisition and transmission efficiency. The testing procedures quantified performance

metrics such as accuracy, sensitivity, and data transmission speed, ensuring the system's robustness and effectiveness. The types of vital signs measured, such as Ecg, heart rate and blood oxygen levels, were accurately captured and transmitted using specific communication protocols, ensuring reliable data exchange between the monitoring device and the Android-based application. Additionally, software testing procedures were conducted to validate the system's software components, ensuring seamless operation and data integrity throughout the monitoring process.



Figure4: Testing to acquire values for ECG, Body temperature and SPO2 Measurement



Figure5: Vitals values as taken from a user.

TIMESTAMP	SPO2	HEART RATE	ECG	TEMPERATURE(C)
2023-11-28 11:55:36	42	35	305	33.3
2023-11-27 15:47:04	88	72	44	35.5
2023-11-27 15:43:08	67	52	1023	35.4
2023-11-26 19:50:07	69	53	728	30.3
2023-11-26 19:35:34	92	74	234	29.6
2023-11-26 19:21:19	52	45	242	31.3
2023-11-26 19:11:34	57	42	66	30.8
2023-11-26 18:58:40	75	61	233	29.9
2023-11-26 18:57:14	59	43	125	30.4
2023-11-26 17:25:21	71	54	136	33.8

Figure6: The measured values as displayed on the mobile App interface

3.6 Model Training and Evaluation

The dataset for the cardiovascular risk prediction system was split into two separate subsets: an 80% training set and a 20% test set. This division facilitated the training of machine learning models on a significant chunk of the data while also keeping a distinct dataset for evaluating the model's ability to generalize and perform. The models were trained using the specified training set, utilizing the wide range of variables included in the dataset. The assessment of model performance was carried out with a specific emphasis on crucial health outcome measures, such as accuracy, precision, sensitivity, and specificity. The selection of these measures was based on their clinical significance and statistical reliability in assessing the efficacy of the predictive model. The implementation and assessment processes were carried out using the scikit-learn module in Python, a frequently employed tool for machine

learning tasks that offers a full range of capabilities for developing models, training, and evaluation.

3.7 Model performance monitoring

Machine learning performance monitoring considers metrics like accuracy, Cross-Validation, hyperparameter, F1-score, ROC-AUC and computational resources, ensuring model effectiveness and reliability.

Let $M_1, M_2, M_3, \dots, M_n$ represent different machine learning models (SVM, Random Forest, Neural Network, Ensemble etc.) considered for prediction.

(a) Cross-Validation and Performance Metrics:

For each model M_i , use $CV(M_i)$ to represent the cross-validation process, which evaluates the model's performance on k folds of the dataset. This yields a set of performance metrics ($Accuracy_1, Accuracy_2, Accuracy_3$), for each model

$$Accuracy_1 = CV(M_i)$$

(b) Hyperparameter Tuning:

Let θ_i denote the hyperparameter space for model M_i .

Use `GridSearchRandomizedSearch` or to find the optimal hyperparameters θ_i for each model, resulting in the best-performing configuration.

$$\theta_i = \operatorname{argmax}_{\theta} CV(M(\theta))$$

$$\theta \in \Theta_i$$

(c) Ensemble Methods:

For ensemble methods (e.g., stacking), combine predictions from different models M meta and create a meta-model to learn from these predictions.

$$M_{\text{meta}} = \text{Ensemble}(M_1, M_2, \dots, M_n)$$

(d) Model Selection Criteria:

Define a selection criterion based on desired factors (e.g., accuracy, interpretability, efficiency).

$$\text{Selected Model} = \operatorname{argmax}_i \text{Criterion}(M_i)$$

$$M_i$$

3.8 Cloud Application (Streamlit)

In the design and development of the Android-Based Remote Cardiac Monitoring Device for Continuous Real-time ECG Signal Acquisition, Transmission, and Analysis, the integration of the Streamlit application layer is paramount for an enhanced user interface and seamless interaction. The Streamlit application layer, operating at the highest level of abstraction, is constructed using the Python programming language and the Streamlit library, facilitating the creation of interactive widgets, visualizations, and other components for the user interface.

Streamlit's user-friendly features, exemplified by functions like `st.write()` for text display and `st.button()` for button creation, contribute to the streamlined development of the UI. Notably, the application layer brings numerous advantages, including a user-friendly interface, interactive functionalities, and easy cloud deployment, thereby enhancing the overall user experience.

In addition to its role in UI development, Streamlit proved instrumental in implementing machine learning models for predictive analytics in cardiovascular risk assessment. Specifically, Streamlit was employed to develop Support Vector Machine (SVM), ensemble models, and

Artificial Neural Network (ANN) models for predicting vital signs in the cardiac monitoring device.

This integration of machine learning models extends the functionality of the Android-Based Remote Cardiac Monitoring Device. Leveraging Streamlit's capabilities, SVM, ensemble, and ANN models were seamlessly integrated, offering predictive analytics for cardiovascular risk assessment. This enables the system to not only acquire and transmit real-time ECG signals but also to predict and monitor vital signs crucial for proactive healthcare.

The cardiovascular risk prediction and monitoring web application, powered by Streamlit, goes beyond providing a user-friendly interface. It incorporates live dashboards and establishes seamless connections with external subsystems. Notably, Streamlit allows developers to focus on backend functionality while entrusting frontend development to the framework, facilitating a more efficient development process.

Furthermore, Streamlit's customization options obviate the need for expertise in HTML, CSS, or JavaScript, allowing for the creation of distinctive and personalized applications. The intuitive interface and interactive features contribute to enhanced user engagement, providing a holistic and user-centric experience.

3.9 Mobile Application dashboard

A Streamlit dashboard can serve as an intuitive interface for visualizing and interacting with physiological data and predictive outputs. This dashboard allows users to explore vital signs such as systolic blood pressure (SBP), diastolic blood pressure (DBP), heart rate, blood oxygen levels, temperature, electrocardiogram (ECG) values, weight, height, sex, and

predictive outputs derived from analytical models (figure 7).

By integrating Streamlit with Python libraries like Pandas, Matplotlib, Plotly, and Scikit-learn, you can create dynamic visualizations and widgets that enable users to analyze and interpret physiological data in real-time. For instance, users can select specific vital signs or demographic variables from dropdown menus, sliders, or checkboxes to visualize trends, correlations, and distributions.

Moreover, the Streamlit dashboard can include interactive components for predictive modeling, allowing users to input demographic information and physiological data to generate personalized health insights. Predictive outputs, such as risk scores for cardiovascular disease or recommendations for lifestyle modifications, can be displayed alongside visualizations of historical data and trends.

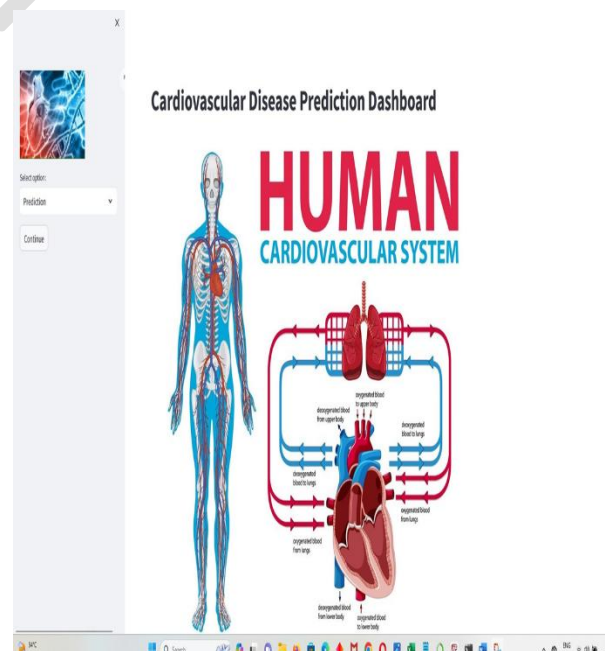

Figure 7: The Application dashboard for the machine learning prediction

3.10 Model selection interface in the Mobile Application

The model is chosen on this interactive interface (figure 8), which allows the system to make predictions based on the specified model with different degrees of accuracy.

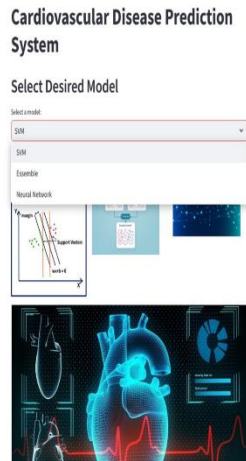

Figure 8: The Mobile App interface for selection of the machine learning model for prediction

3.11 Model selection with SVM:

The decision to use Support Vector Machines (SVM) in a Cardiovascular Risk Prediction System that incorporates real-time physiological information from a wearable device is based on numerous beneficial characteristics (figure 9). Support Vector Machines (SVMs) are highly effective in processing multivariate data, enabling the efficient examination of several vital signs concurrently, a critical aspect in cardiovascular risk evaluation. Their ability to capture non-linear correlations using kernel functions is well-suited for the potentially intricate and non-linear connections between physiological data and cardiovascular risk. Furthermore, Support Vector Machines (SVMs) exhibit resilience in extrapolating from restricted datasets, which is a desirable characteristic in

healthcare situations where data accessibility may be limited. The inherent feature selection capability of Support Vector Machines (SVMs) facilitates the identification of the most influential vital signs for risk prediction, hence improving interpretability. Considering their established reputation and expertise in the field of machine learning, Support Vector Machines (SVMs) are a highly viable option. However, the final decision should involve a comprehensive assessment of factors such as dataset characteristics, computational complexity, and the desired balance between model interpretability and performance.

$$\text{Accuracy}_{\text{SVM}} = \text{CV}(\text{SVM})$$

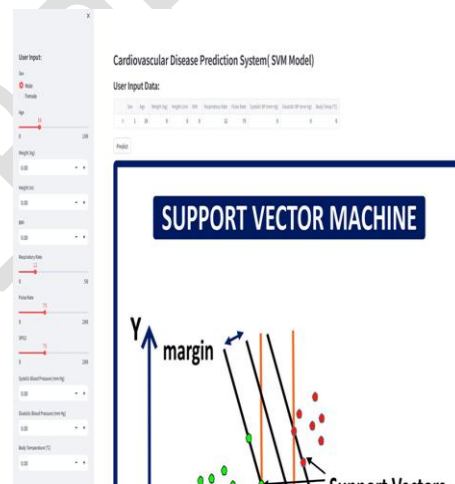

Figure 9: Support vector machine model interface after selection

3.12 Ensemble methods for vital signs:

Utilising ensemble models in a Cardiovascular Risk Prediction System that uses real-time physiological data from a wearable device offers numerous significant advantages (figure 10). Ensemble approaches, such as Random Forest, Gradient Boosting, or Voting Classifier, combine predictions from several models to improve predictive accuracy and robustness. Ensemble approaches are particularly effective in catching multiple

patterns and nonlinear linkages within the data when it comes to predicting cardiovascular risk. This is because cardiovascular risk prediction involves complex relationships between many physiological markers and the risk itself. These models combine the advantages of various methods, thereby reducing overfitting and improving the ability to generalise to new data. This is important in situations when frequent updates are necessary to respond to changing health circumstances. In addition, through the use of ensemble techniques, the system is able to develop a more thorough understanding of the complex relationship between various vital signs. This enhances the reliability of the model and has the potential to improve its ability to identify subtle yet important indicators of cardiovascular risk, resulting in more precise and timely risk assessments.

Accuracy Ensemble = CV(Ensemble)

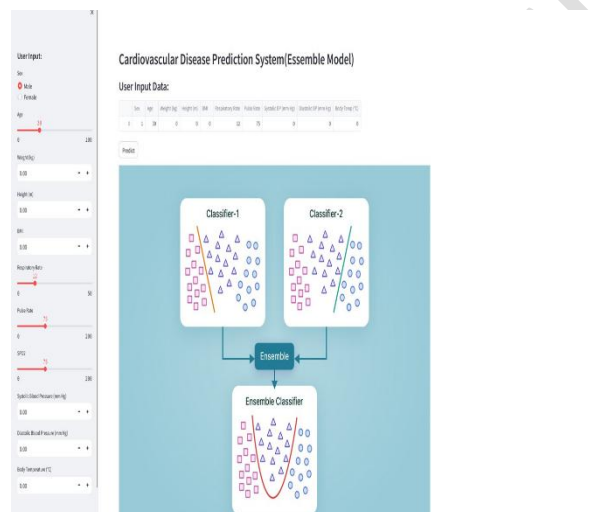

Figure 10: Ensemble model interface after selection

3.13 Neural network model:

The use of neural network models in a Cardiovascular Risk Prediction System, which utilises real-time physiological information from a wearable device, provides significant benefits due to their

ability to effectively process complicated and high-dimensional data, as well as identify detailed patterns. Artificial Neural networks have the capacity to acquire complex nonlinear connections in physiological data, enabling the investigation of intricate interconnections among different vital signs that could potentially contribute to cardiovascular risk (figure 11). Due to their hierarchical architecture and capacity to adjust to various data representations, they are highly suitable for identifying intricate and subtle correlations between different physiological measures and potential risk factors. Furthermore, Artificial neural networks demonstrate exceptional proficiency in extracting and abstracting features, allowing them to independently identify significant characteristics from unprocessed data. This capability enables them to potentially reveal hidden clues that conventional methods may fail to detect. Artificial Neural networks are capable of adjusting to changing data streams from wearable devices, allowing for real-time learning. This means that the system may continuously improve its capacity to make predictions as it receives new information. Utilising neural network models in this context shows potential for improving the accuracy and sensitivity of cardiovascular risk forecasts, providing a mechanism to achieve more efficient and proactive healthcare interventions.

Accuracy = CV(NN)

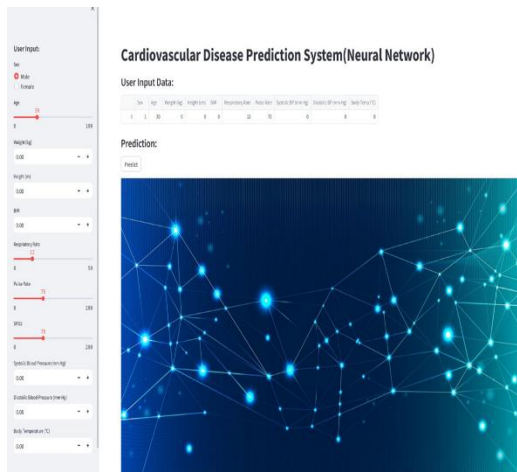

Figure 11: Artificial Neural Network model interface after selection

4.0 Results

The developed Android-based remote cardiac monitoring system successfully achieved real-time acquisition, processing and transmission of ECG signals. The hardware unit with sensors and electrodes captured ECG signals which were amplified, filtered and processed by the microcontroller and algorithms. The machine learning models including SVM, ensemble methods and neural networks were trained to classify ECG signals and detect anomalies with accuracy ranging from 83% to 87%.

The system's ability to acquire signals remotely, connect to cloud databases, transmit and visualize data in real-time was validated through comprehensive testing. Key metrics like signal clarity, noise reduction, classification performance, transmission speeds and data security were quantified to benchmark the system's effectiveness for practical deployment.

5.0 Conclusion

The project demonstrates the feasibility of an end-to-end Android-based system for remote cardiac monitoring through rapid

acquisition, transmission and analysis of ECG signals. The integration of hardware, algorithms and machine learning models enables accurate classification and prediction of cardiac abnormalities. The system's capabilities in real-time signal monitoring, processing and anomaly detection facilitates timely interventions by healthcare professionals. By surmounting limitations in traditional approaches, the solution helps expand accessibility of cardiac care beyond clinical settings. Overall, the system holds substantial promise in advancing preventive medicine while empowering individuals to proactively manage their heart health. The affordable, user-friendly and round-the-clock monitoring enhances early diagnosis, personalized treatment and improved outcomes.

5.1 Recommendations

While results validate the system's efficacy, further work should focus on:

- Testing on expanded patient datasets from diverse demographics
- Enhancing security measures to safeguard confidential medical data.
- Exploring interconnectivity with existing hospital infrastructures
- Scaling system capabilities to handle large volumes of patient data.
- Assessing user adoption rates to maximize clinical impact.

In addition, augmenting the system's machine learning models using emerging AI techniques could further optimize predictive accuracy over time. Overall, the project shows immense potential and further development along the suggested lines can

better position the solution for mainstream adoption in cardiac care.

6.0 REFERENCES

Wahane, V., & Ingole, P. V. (2016, November). An android based wireless ecg monitoring system for cardiac arrhythmia. In 2016 IEEE Healthcare Innovation Point-Of-Care Technologies Conference (HI-POCT) (pp. 183-187). IEEE.

Kakria, P., Tripathi, N. K., & Kitipawang, P. (2015). A real-time health monitoring system for remote cardiac patients using smartphone and wearable sensors. *International journal of telemedicine and applications*, 2015, 8-8.

Singh, M., Singh, G., Singh, J., & Kumar, Y. (2021). Design and validation of wearable smartphone based wireless cardiac activity monitoring sensor. *Wireless Personal Communications*, 119(1), 441-457.

Sahu, M. L., Atulkar, M., Ahirwal, M. K., & Ahamad, A. (2021). IoT-enabled cloud-based real-time remote ECG monitoring system. *Journal of medical engineering & technology*, 45(6), 473-485.

Benjaman, A., Ltifi, H., & Ayed, M. B. (2020). Design of remote heart monitoring system for cardiac patients. In *Advanced Information Networking and Applications: Proceedings of the 33rd International Conference on Advanced Information Networking and Applications (AINA-2019)* 33 (pp. 963-976). Springer International Publishing.

Bazi, Y., Al Rahhal, M. M., AlHichri, H., Ammour, N., Alajlan, N., & Zuair, M. (2020). Real-time mobile-based electrocardiogram system for remote monitoring of patients with cardiac arrhythmias. *International Journal of Pattern Recognition and Artificial Intelligence*, 34(10), 2058013.

Mohamed, N., Kim, H. S., Mohamed, M., Kang, K. M., Kim, S. H., & Kim, J. G. (2023). Tablet-Based Wearable Patch Sensor Design for Continuous Cardiovascular System Monitoring in Postoperative Settings. *Biosensors*, 13(6), 615.

Ahmed, H. I., Saleem, D. M., Omair, S. M., Shams, S., Sheikh, N., & Tariq, A. (2022). Conceptual Hybrid Model for Wearable Cardiac Monitoring System. *Wireless Personal Communications*, 125(4), 3715-3726.

Al-Mafrachi, D. G. A. (2020). Body health monitoring and alarm system by using android wear device (Master's thesis, Altınbaş Üniversitesi/Lisansüstü Eğitim Enstitüsü).

Noorwali, A., Yengui, A., Ammous, K., & Ammous, A. (2022). Design and realization of non invasive fetal ECG monitoring system. *Intelligent Automation & Soft Computing*, 32(1), 455-466.

Roy, S., Hanks, K., Tetali, S. M., Guthrie, K. L., & Boci, E. S. (2021, October). Arduino IoT based Cardiac Health Monitor. In 2021 IEEE 4th 5G World Forum (5GWF) (pp. 212-217). IEEE.

Bertogna, E. G., Machado, F. M., & Sovierzoski, M. A. (2020). An optimized ECG android system using data compression scheme for cloud storage. *Health and Technology*, 10(5), 1163-1171.

Gonzalez-Fernandez, R. I., Mulet-Cartaya, M., de Oca-Colina, G. M., Aguilera-Perez, J., Lopez-Cardona, J. D., & Hernandez-Caceres, J. L. (2022). Low-cost Approaches to Follow-up Cardiac Patients in Low-Income Countries using Public Data Networks. In *Telehealth/Telemedicine—The Far-Reaching Medicine for Everyone and Everywhere*. IntechOpen.

Singh, N. P., Kanakamalla, A., Shahzad, S. A., Divya Sai, G., & Suman, S. (2022).

Remote Monitoring System of Heart Conditions for Elderly Persons with ECG Machine Using IOT Platform. *Journal of Information Systems and Telecommunication (JIST)*, 1(37), 11.

Tambe, P. M., Katkade, M. B., Ahire, M. D., Vighne, M. A., & Pawase, R. S. IOT BASED PORTABLE ECG MONITORING SYSTEM FOR SMART HEALTHCARE.

Christ, J., Lakshmi Narayanan, A., & Jothiraj, S. (2020). Low Cost Internet of Things Based Remote Monitoring System and ECG Analysis. *Journal of Computational and Theoretical Nanoscience*, 17(4), 1863-1866.

Umar, U., Khan, M. A., Irfan, R., & Ahmad, J. (2021, July). IoT-based cardiac healthcare system for ubiquitous healthcare service. In *2021 International Congress of Advanced Technology and Engineering (ICOTEN)* (pp. 1-6). IEEE.

Owolabi, M., Miranda, J., Yaria, J., & Ovbiagele, B. (2016). Controlling cardiovascular diseases in low and middle income countries by placing proof in pragmatism. *BMJ Global Health*, 1. <https://doi.org/10.1136/bmjgh-2016-000105>.

Afoakwah, C., Nghiem, S., Scuffham, P., & Byrnes, J. (2021). Rising unemployment reduces the demand for healthcare services among people with cardiovascular disease: an Australian cohort study. *The European Journal of Health Economics*, 22, 643 - 658. <https://doi.org/10.1007/s10198-021-01281-5>.

Lee, R., & Mittal, S. (2017). Utility and limitations of long-term monitoring of atrial fibrillation using an implantable loop recorder.. *Heart rhythm*, 15 2, 287-295. <https://doi.org/10.1016/j.hrthm.2017.09.009>.

Mena, L., Felix, V., Ochoa, A., Ostos, R., González, E., Aspuru, J., Velarde, P., &

Maestre, G. (2018). Mobile Personal Health Monitoring for Automated Classification of Electrocardiogram Signals in Elderly. *Computational and Mathematical Methods in Medicine*, 2018. <https://doi.org/10.1155/2018/9128054>.

McConnell, M., Turakhia, M., Harrington, R., King, A., & Ashley, E. (2018). Mobile Health Advances in Physical Activity, Fitness, and Atrial Fibrillation: Moving Hearts.. *Journal of the American College of Cardiology*, 71 23, 2691-2701. <https://doi.org/10.1016/j.jacc.2018.04.030>.