

# INTERNATIONAL TOURISTS' SATISFACTION ON THE DEPARTURE NON - PROCESSING SERVICE PERFORMANCE AT KILIMANJARO INTERNATIONAL AIRPORTS IN TANZANIA

## Abstract

This study assessed the relationship between airport departure non-processing service performance and international tourists' satisfaction at Kilimanjaro International Airport. A survey research design and quantitative approaches with stratified sampling and a 162 sample size were adopted. Data collection was done through closed-ended questionnaires. Data analysis was done using IBM SPSS statistics version 21 and Partial Least Squares – Structural Equation Modelling using SmartPLS 3 software with the help of SmartPLS3 software. The study showed that airport departure facilities were directly and significantly associated with international tourists' satisfaction. This implies that the relationship exists in real life, and any effort to disregard the assessment of these facilities may disturb tourists' satisfaction and lead to untrustworthiness. Moreover, airport departure accessibility and departure retail areas showed an insignificant association with international tourists' satisfaction, implying that no relationship exists in real life. The study recommends that indicators for the constructs with direct relationships be treated as significant factors. However, airport operators should equally monitor service performance in all three constructs to make tourists loyal since any service compromise can interrupt tourists' satisfaction.

**Keywords:** Departure Airport Accessibility, Departure Retail Area, Departure Airport Accessibility.

## 1. Introduction

Airports are the most delicate segment of the tourism sector as they provide access to different tourist locations worldwide (Soshkin *et al.*, 2019; Khoshnood *et al.*, 2016; Rijal, 2018). Various countries regard airports as a substantial representation of tourism promotion. Henceforth, their desirability and regular upgrading create an assured image to meet tourist expectations (Nugraha, 2017; Rijal, 2018). Stunning airport designs build a sense of tourism appeal that can entice tourists to vacations, spending, stay-overs, and other non-restricted activities and avoid making it just an interchange for numerous modes of transport (Gupta & Venkaiah, 2018).

Global tourist flow increased the number of flights worldwide (Ilmu *et al.*, 2018). According to Liu *et al.* (2019), more than 1,303 airlines operating almost 31,717 airplanes are served by approximately 3,759 airports globally. Soshkin *et al.* (2019) reported an increase in international arrivals of 4.5% in 2018, which was motivated by the enhancement of airport infrastructures and other services. According to Sasu (2022), it is anticipated that in 2035, there will be over 7.2 billion and 17 billion 2050 air travellers in the world. However, the COVID-19 pandemic affected tourist flow due to travel restrictions (Ruwan *et al.*, 2020). In Africa, statistics show that tourist arrivals in 2018 were 1.4 billion worldwide, 91.99 million, and 1.5 million in Tanzania (Berthe, 2019). Based on global statistics, Africa's tourism sector is anticipated to proliferate in the next 20 years (Eleboda, 2017).

**Comment [NP1]:** The manuscript on international tourists' satisfaction with departure non-processing services at Kilimanjaro International Airport in Tanzania contributes valuable insights to the scientific community

**Comment [NP2]:** The title of the article, "INTERNATIONAL TOURISTS' SATISFACTION ON THE DEPARTURE NON - PROCESSING SERVICE PERFORMANCE AT KILIMANJARO INTERNATIONAL AIRPORTS IN TANZANIA," effectively conveys the focus of the study on international tourists' satisfaction with departure non-processing services at Kilimanjaro International Airport in Tanzania. However, a minor improvement could be made for clarity and conciseness:  
Alternative Title: "Satisfaction of International Tourists with Departure Services at Kilimanjaro International Airport: A Study in Tanzania"

**Comment [NP3]:** Overall, the abstract provides a concise summary of the study's objectives, methodology, findings, and recommendations. However, it could be improved by providing more specific details about the methodology, such as how the survey was conducted and the specific measures used to assess satisfaction and service performance. Additionally, including more context about the significance of the study and its potential implications for tourism management in Tanzania could enhance the comprehensiveness of the abstract.

**Comment [NP4]:**

**Comment [NP5]:** •The introduction subsections and structure of the manuscript appear appropriate. Overall, the subsections flow logically and provide sufficient context for the study's objectives and rationale. Here are some suggestions for improvement in the introduction section: *Focus on Key Points:* Trim down some of the less essential background information to maintain focus on the main points. For instance, while statistics on global tourist flow and the COVID-19 pandemic are relevant, ensure they directly contribute to framing the study's context and objectives. *Highlight Study's Contribution:* Emphasize the

Most airports use unconventional strategies to attract tourists, resulting in high airport service competition (Gupta and Venkaiah, 2018). Irrespective of the willpower to advance in airport service provision, service delivery imperfections cannot entirely be eliminated (Saayman, 2018). Equally, scaling failure costs is difficult because inconsequential failures may result in undesired outcomes. The researchers have emphasized the quality of airport service performance due to its influence on satisfaction and destination re-visitation. In Africa, regardless of the challenges in the aviation industry during the pandemic, tourists are often infuriated by the unhappy service performance at airport terminals (AFRAA, 2022; Adetayo et al., 2020). Ovuorie (2022) and Kinyondo *et al.* (2020) have described the airport challenges in Africa in detail. Literature suggests that African countries should advance their airports to attract more tourists. Therefore, the role of airport departure non-processing domain in tourism performance should not be treated as piecemeal but as a factor influencing tourists' satisfaction (Abdullahi *et al.*, 2018). Chi *et al.* (2018) recommended more research on the relationship because of the global competition in the tourism industry.

The quality of service performance at the airport terminal determines tourists' satisfaction. As such, tourists' changing behaviour based on demographic characteristics and nationalities plays a significant role in the dynamics of tourist satisfaction. Tourists' last impressions end during departure at the airport terminals, where they can either be satisfied or dissatisfied. Cognizant of this, there is a need to investigate further the connection between airport departure non-processing services performance and international tourists' satisfaction. Airport operators take many precautions to avoid dissatisfaction by clearly understanding tourists' perceptions and getting feedback after service provision (Lohmann *et al.*, 2018; Adeniran, 2018). It is a rule of thumb that once airport service performance is in good order, tourists will automatically flow in, leading to massive revenue generation.

The present study analyzed the connection between airport departure non-processing services performance and international tourists' satisfaction at the Kilimanjaro International Airport (KIA), one of the country's most significant destinations for international tourist arrivals. Despite the passenger popularity of KIA, many tourists have complained about the quality of services offered at the airport. These complaints are documented by McSherry (2020) as problems regarding dedicated sleeping areas, quiet areas or rest zones, 24-hour options for food and drinks, taxi fare, and luggage storage and lockers. Similar results were reported by McSherry (2017) and Maestro (2017), which affect the tourism industry's effective contribution to Tanzania's Gross Domestic Product. Unlike departure processing, studies about passenger satisfaction regarding departure non-processing, specifically at KIA, are limited (Wiredja, 2017). Likewise, studies on airport service performance and tourist satisfaction are inadequate in Tanzania. Few studies in Tanzania address airline and air transport service quality (Amara, 2020; Benson, 2022). Apart from the scanty knowledge available, as reported by Kramer (2013), herewith are some literature reviews regarding the study (Popovic *et al.*, 2009; Park *et al.*, 2011; Popovic *et al.*, 2010; Wiredja *et al.*, 2019; Bakiret *et al.*, 2022; and Chi *et al.*, 2022). Wattanacharoensil (2019) invited academicians to explore the challenge further. Therefore, the study analyzed the relationship between airport departure non-processing service performance and international tourist satisfaction at KIA. The study adopted the passenger-centered airport model (PCAM) that consists of airport processing and non-processing domains touching arrival, departure, and transit to assess tourists' experience at the airport was recently developed by Wiredja *et al.* (2019), with

slight modifications to assess the connection between airport departure non-processing services performance and international tourists' satisfaction at KIA.

## **2. Material and methods**

### **2.1 Theoretical Framework**

#### **2.1.1 Expectancy Disconfirmation Theory**

The study used the Expectancy Disconfirmation Theory (EDT) to investigate the link between airport departure non-processing service performance and international tourists' satisfaction. Many researchers have used the theory to analyze the relationship between service offered and satisfaction. For instance, Elaine (2013) used the theory to evaluate the relationship between customer satisfaction and service quality in health care. Zhang *et al.* (2022) and Ryzin and Gregg (2006) adopted the same theory to examine the link between the services provided by local governments and private sectors and community satisfaction. Fisun and Atila (2001) applied the theory to assess tourists' perceptions in the tourism and hospitality industry. According to Lyons *et al.* (1992), the direct relationship between perceived service performance and satisfaction is naturally positive and strong.

The theory clearly describes satisfaction through disconfirmation after comparing the expected and perceived services (Patterson *et al.*, 1997; Premkumar and Bhattacharjee, 2004). Oliver (1980) and Tse *et al.* (1988) were the first pioneers to use this theory in their studies, after which several amendments were made to suit several studies. A good example is Cheng (2019), who combined Herzberg's two-factor and expectancy disconfirmation theories to analyze tourists' satisfaction. The present study adopted a similar theory by integrating it with the Passenger Centered Airport Model (PCAM) developed by Wiredja *et al.* (2019) to assess the clear link between airport departure non-processing service performance and international tourists' satisfaction. The study used only two constructs from the same theory (perceived performance and satisfaction) by integrating with the PCAM to assess the relationship between airport arrival non-processing service performance and international tourists' satisfaction. The model contains constructs and indicators that the study addressed as perceived services at the airport terminal.

The theory overlooked the inclusion of service indicators. Due to that fact, the study borrowed constructs and their indicators from the PCAM to support the theory. Thus, departure airport facilities, departure retail areas, and departure airport accessibility being departure non-processing constructs/domains in the PCAM were adopted in assessing tourist satisfaction at KIA (Wiredja *et al.*, 2019). Accordingly, the theory's perceived performance construct was also segmented into three constructs based on the fact that Wiredja *et al.* (2019) disjointed arrival non-processing domain into arrival retail area, arrival facilities, and arrival airport access. In their study, Wiredja *et al.* (2019) suggested that interested researchers can add additional indicators to improve service performance at the airport terminal based on the area of study. Therefore, PCAM modification inevitably reflected the indicators added to the literature. Figure 1A shows the actual EDT, and Figure 1B shows the actual PCAM, which contains the constructs and indicators used in the present study.

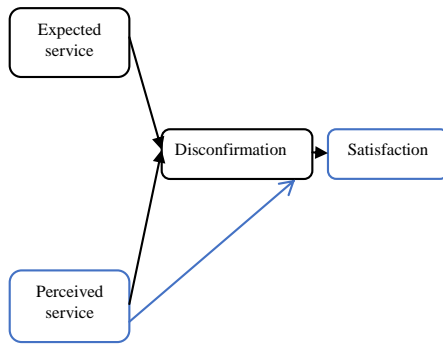

**Figure 1A: EDT actual Model**  
 Source: Oliver (1980)

Key: ——— Adopted constructed

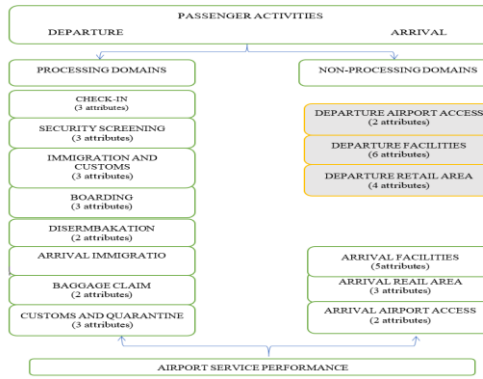

**Figure 1B: Actual PCAM**  
 Source: Wiredjeet *et al.* (2019)

### 2.1.2 The Link between EDT and PCAM

The attributes/indicators in the highlighted constructs in Figure 1B were considered the perceived services offered to international tourists at the airport terminal. Hence, international tourists judged the service performance by rating their level of satisfaction and comparing their desired services to perceived service. Table 1 shows the relationship between the expectancy disconfirmation theory and PCAM.

**Table 1: The link between EDT and PCAM**

Expected Disconfirmation Theory	Arrival non-processing domain (Independent variable) (Expected Services+ Perceived Services)	Satisfaction (Dependent variable)
Perceived Services performance at the Airport Terminal	<p>a. Indicators at the departure arrival facilities (waiting lounge is attractive and comfortable, seats are adequate and comfortable, clear information desk, display, and signs, the conditions of baggage trolley, the convenient location of baggage trolley, cleanliness of the terminal floor, facilities, and public areas cleanliness, the terminal physical environment is good and comfortable, overall terminal comfort)</p> <p>b. Indicators at the departure retail area (variety of retail shops and cafes, value for money for the shops and cafes, availability of a variety of food and beverages, clear tourism information, goodness of restaurant/cafes services and environment, and reasonable Covid 19 precaution and safety protocol)</p> <p>c. Indicators of the departure airport accessibility (availability of various transport options from city to town, satisfactory tax fare and parking facilities, and accessible car parking)</p>	International tourist Satisfaction

Source: Researcher (2024)

### 2.1.3 Research hypotheses

Tourists can have time to perform unrestricted activities after completing restricted tasks at check-in, immigration, and security screening. Unrestricted activities are conducted in three departure non-processing domains: airport facilities, airport retail areas, and airport accessibilities (Wiredja et al., 2019). Each domain (construct) contains its indicators for satisfaction assessment. The satisfaction or dissatisfaction of tourists in these domains depends on service providers (Sumanasiri et al., 2020). Easy accessibility to the airport positively affects tourists' satisfaction (Wiredja et al., 2017; Chen et al., 2012). More details regarding airport accessibility have been explained by Wiredja et al. (2019), Adeniran et al. (2018), Prentice et al. (2019), and the references therein. The influence of airport departure facilities on tourists' satisfaction has further been investigated by Ansari et al. (2020). Money exchange services, cleanliness of airport facilities, baggage carrying trolleys, and the internet were conveyed to influence satisfaction positively (Yavuz et al., 2021; Smith, 2018). The relationship between departure facilities and tourist satisfaction was further studied by Mwesiumo and Halpern (2021) and Wiredja et al. (2019). The formulated hypotheses for the present study are as follows;

*H<sub>1</sub>: Services at the airport departure accessibility directly correlate with international tourist satisfaction.*

*H<sub>2</sub>: Services at the airport departure facilities directly correlate with international tourist satisfaction.*

According to Wiredja et al. (2017), the departure retail area comprises various shops, cafes, food and beverages. Tourists can enjoy the available decorations, attractions, and value-for-money products before boarding. Yavuz et al. (2021) revealed that services provided in this domain, such as seating capacity, sleeping areas, queuing, and cleanliness, affect satisfaction and intention to reuse the airport. Staff approachability and kindness have also been suggested by Wiredja et al. (2019) to satisfy tourists. Reports by Kramer (2013), Correia et al. (2008), and Wiredja et al. (2017) show that studies regarding departure retail areas are limited. Service disappointment in restaurants, snack bars, cafes, shopping, and related services influences tourists' dissatisfaction (Seetanah, 2018; Mwesiumo and Halpern, 2021; Hajez and Fawzy, 2021). More information about departure retail areas has been reported by Ansari and Agarwah (2020), Putra et al. (2021), Smith (2018), and Phuyal et al. (2018). The formulated hypothesis is as follows;

*H<sub>3</sub>: Services at the airport departure retail area directly correlate with international tourist satisfaction.*

## 2.2 Empirical Literature Review

Airports are vital for tourists to experience and contribute to tourist satisfaction. Kirk (2012) and Prebezac et al. (2010) report revealed that airport departure facilities influence tourists' satisfaction. Thus, determining travellers' satisfaction with airport service improvement is necessary. Service provision at this construct gives tourists the first impression of the country (Gajewicz et al. 2022 and Tsai et al. 2011). Several factors are most valued when interacting with international tourists, including cleanliness, condition, and the location of baggage trolleys (Prentice and Kadan 2019; Smith 2018). According to Yavuz et al. (2021), the friendliness of

restaurant and shop attendants, the cleanliness of washrooms, and value for money tend to influence international tourists' satisfaction at the airport terminal. Likewise, physical ambiance, shopping areas, and rest zones significantly contribute to overall tourist satisfaction (Mwesiumo and Halpern, 2021; Sumanasiri and Dambagola, 2020). Bakıret al. (2022) propound that consistent internet connectivity, airport shopping, and shopping facilities influence international tourists' satisfaction. Other recent studies regarding airport departure facilities have been conducted by Krishan and Kumar (2022), George et al. (2020), Aydoğan (2021), Kratudnak et al. (2018), Bellizzi et al. (2018), and the reference therein. Currently, some airport operators consider providing free services to departing travellers to give them a positive impression regardless of the time spent at the departure lounge. Therefore, assessing tourists' experience in airport departure facilities is essential to improve tourism and airport service performance.

The departure retail area is part of the airport departure non-processing service performance, containing diverse shops, cafes, food, and beverages for tourists to enjoy value-for-money products. According to Wiredja et al. (2017), little research has been done about the domain since researchers regarded it as inconsequential in influencing tourists' satisfaction. Service failure in shopping and cafes has been reported to have little impact on tourists' satisfaction (Bezerra et al. 2015; Mwesiumo and Halpern 2021). Hajez and Fawzy (2021) explain that the reputation of airport restaurants, snack bars, and value for money significantly affect tourists' satisfaction. The actions and behaviour of attendants during service provision and friendliness similarly determine tourists becoming repeat visitors (Olgaec et al. 2021; Putra et al. 2021). Regardless of the investments made to promote the tourism industry, more research is required to perfect the quality of service provision at the airport (Ansari and Agarwah, 2020). Disregarding airport departure non-processing service performance can lead to negative economic impacts due to the dissatisfaction of tourists. It is worth it for a tourist to spend money at the café while waiting to board rather than relaxing in a waiting lounge. Therefore, when the service offered is below standard, or the waiting area is not pleasing or absent, or when such a service is not conducive or is missing, tourists become dejected and are likely to spread negative word of mouth.

Transport availability at the airport terminal has been reported to influence satisfaction. Travellers can either hire or pick up the ready-prepared transport to the airport after the completion of tourism activities. Airport departure accessibility has been overlooked by many researchers when assessing airport service performance (Wiredja et al., 2017). Adeniran et al. (2018) and Sumanasiri and Dambagola (2020) reported that arrival accessibility has a weak impact due to low-efficiency transport to satisfy passengers. Figure 2 shows the conceptual framework that was adopted in this study.

### Independent Variables

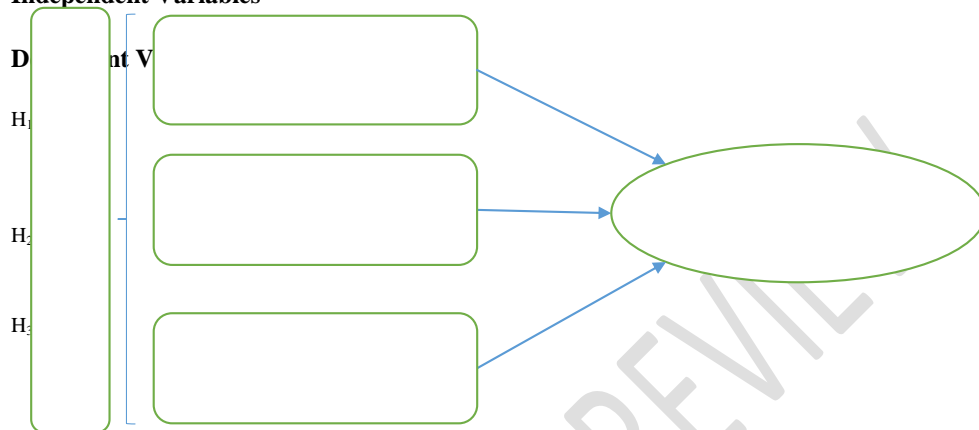

**Figure 2: Conceptual Model**  
Source (Researcher, 2024)

### 2.3 Methodology

This study used a quantitative research design to assess the link between airport departure non-processing service performance and international tourists' satisfaction. The sample size included 162 international tourists obtained through stratified sampling (Hair et al., 2018). Structured questionnaires with closed-ended questions were used to collect quantitative data. The questionnaire included demographic information like educational background, respondent's travel experience, sex, and age to serve the study objective. The Five Likert scales were employed, and data were coded for precise analysis and interpretation. Table 2 shows the list of indicators used in the study.

**Table 2: List of service indicators for the three constructs used in this study**

S/N	Departure Airport Accessibility (DAA)	Code	Remark
1.	A variety of transport options from the city to the airport are available	DAA1	PCAM
2.	Parking facilities are available, and it is easy to find a car park	DAA2	PCAM
3.	The taxi fare is satisfactory.	DAA3	PCAM
<b>Departure Airport Facilities (DAF)</b>			
4.	The airport waiting lounge is attractive and comfortable	DAF3	PCAM
5.	The seats at the airport are adequate and comfortable	DAF4	Added
6.	The airport has a clear information desk, display, and signs	DAF5	PCAM
7.	Baggage trolleys are in good condition and conveniently located	DAF6	Added
8.	The terminal floor, facilities, and public areas are well-cleaned	DAF11	Added
9.	The overall terminal comfort is satisfactory.	DAF14	Added
10.	The terminal physical environment is good	DAF15	Added
<b>Departure Retail Area (DRA)</b>			
11.	A variety of retail shops and café are available at the airport	DRA1	PCAM

12.	Prices at shops and café are valued for money at the airport	DRA2	PCAM
13.	The café/restaurant service and environment are good at the airport	DRA3	Added
14.	A variety of foods and beverages are available at the airport	DRA4	PCAM
15.	I got clear tourism information at the airport	DRA5	Added
16.	There are good COVID-19 precautions and safety protocols during departure	DRA6	Added
<b>International Tourists Satisfaction (ITS)</b>			
17.	I will communicate positive word of mouth about Tanzania to fellow people in my country.	ITS1	Added
18.	The good services at the airport made me plan another trip to Tanzania	ITS2	Added
19.	Employees at the airport terminal are customer-focused	ITS3	Added
20.	The overall services performed at the airport were satisfactory	ITS4	Added
21.	I will recommend others in my country to visit Tanzania	ITS5	Added

### 3. Data analysis

Two stages were involved in performing Partial Least Square (PLS)-Semi Equation Modelling through SmartPLS3 software. The first stage analyzed measurement models comprising indicator reliability, convergent validity, discriminant validity, and internal consistency reliability. In the second stage, the structural measurement model covering collinearity, coefficients of determination ( $R^2$ ), significance and relevance of path coefficients (P-value),  $f^2$ - effects size of path coefficients, and predictive relevance ( $Q^2$ ) was analyzed as explained by Hair *et al.* (2018). Since the construct influenced indicators, the reflective measurement model was used to assess the process. Based on the nature of the study and data, the advanced method implanted in SmartPLS3 software was appropriate for the data analysis (Sartedt et al., 2017). Therefore, to assess the fitness of the proposed model, bootstrapping, blindfolding, and PLS algorithms were performed in the SmartPLS3 software.

### 4. Results

#### 5.1 Demographic Profile of the Respondents

Descriptive analysis showed that males were dominant for 57.1%, while females constituted 42.9%. Respondents aged between 18 and 35 were 33.5%, 36 and 50 were 28.6%, and above 50 constituted 37.9%. Respondents with a first degree were 36.5%, Masters and Ph.D. were 50.9%, and secondary education were 11.9%. This implies that the respondents had substantial knowledge and understanding and were mature enough to examine the questions. Regarding the purpose of the visit, 82% of the respondents visited for tourism, 13% for meetings/conferences, 3.7% for business, and 1.2% for other purposes. The frequency of visits revealed that 75.3% visited Tanzania for the first time, 7.4% for the second time, 3.1% for the third time, and 14.2% more than three times. These findings imply that tourists gave precise information based on their experience because the highest number had visited Tanzania for the first time. Thus, airports must offer sustainable service performance to attract more new and repeat visitors.

#### 5.2 Findings for the Reflective Measurement Model

The findings showed that the reliability of the indicators was above 0.708, as recommended by Hair *et al.* (2018). Furthermore, the values for composite reliability were above 0.708 and below 0.95. Convergent validity measures Average Variance Extracted (AVE) was above 0.5, as Hair *et al.* (2018) recommended. This indicates that the constructs contributed more than 50% of the variance items making up the construct. The discriminant validity was below 0.9 for all the study constructs, as suggested by Hair *et al.* (2018). This indicates that the constructs were not

**Comment [NP6]:** The findings for the Structural Measurement Model of the manuscript appear to be appropriate. The analysis addresses key statistical measures such as collinearity values (VIF), effect size ( $f^2$ ), significance levels (P-values),  $Q^2$  values, and  $R^2$  values.

interrelated. Figure 3 presents the relevance of the indicator loading, path coefficient, average variance extracted, and discriminant validity.

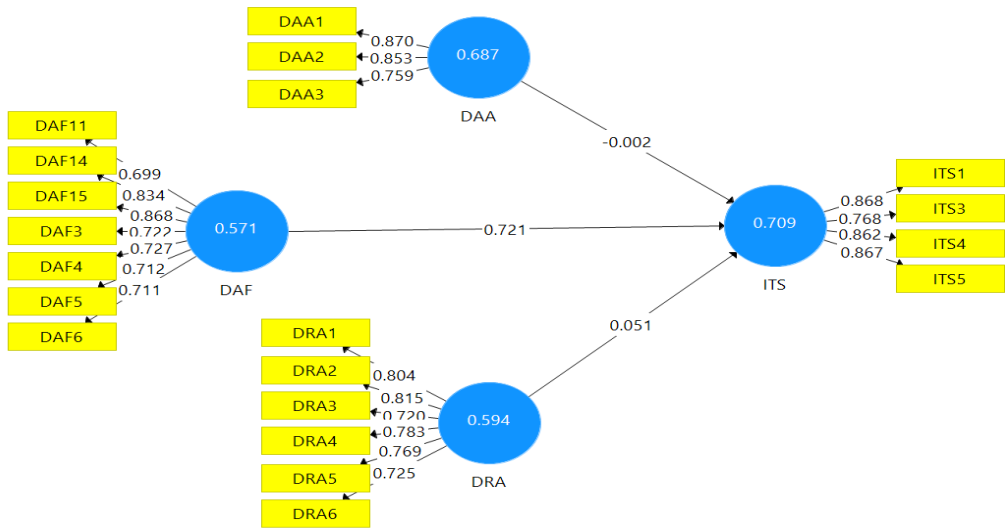

**Figure 3: Relevance of the path coefficient**

Source: Author, 2024

Key: Departure Airport Accessibility (DAA), Departure Airport Facilities (DAF), Departure Retail Area (DRA), International Tourists Satisfaction (ITS)

**Table 3: Internal Construct Reliability, AVE, and HTMT Values**

	Composite Reliability	Average Variance Extracted (AVE)	Discriminant Validity Results by using (HTMT)		
			DAA	DAF	DRA
Departure Airport Accessibility (DAA)	0.785	0.687			
Departure Airport Facilities (DAF)	0.874	0.571	0.517		
Departure Retail Areas (DRA)	0.867	0.594	0.466	0.741	
ITS	0.862	0.709	0.379	0.853	0.572

Source: Author, (2024)

**5.3 Findings for the Structural Measurement Model**

According to Hair *et al.* (2018), collinearity values of less than five are recommended to affect the interpretation of the overall model. The results showed that the collinearity statistics (VIF) value was less than 4, inferring the absence of multicollinearity problems among the constructs. Hair *et al.* (2018) recommend that  $f^2$  values higher than 0.02 depict a small effect, 0.15 shows a medium effect, and 0.35 represents a large  $f^2$  effect size. From the findings, the  $f^2$  effect size of 0.000 and 0.003 implied the absence of effect for the departure airport accessibility and departure retail area toward international tourists' satisfaction. In contrast, the  $f^2$  value of 0.616 indicates a strong impact of departure airport facilities on international tourists' satisfaction. Henceforward, the relationship between departure airport accessibility and international tourists' satisfaction, departure retail area, and global tourists' satisfaction can be mediated or dropped.

**Comment [NP7]:** The findings for the Structural Measurement Model of the manuscript appear to be appropriate. The analysis addresses key statistical measures such as collinearity values (VIF), effect size ( $f^2$ ), significance levels (P-values), Q2 values, and R2 values.

Likewise, the results showed one significant hypothesized relationship (departure airport facilities and international tourist satisfaction), implying that an increase in one standard deviation increased the rate of tourist satisfaction. The direct hypothesized relationships were statistically significant with the P-value  $\leq 0.05$ , indicating that the hypothesized relationship exists in real life. However, two direct hypothesized relationships were statistically insignificant because the P-values were above the value recommended by Hair *et al.* (2018). This implies that the hypothesized relationships were rejected. Hence, no direct relationship existed between the constructs. A further implication is that the indirect relationship can be tested through mediation variables or dropped. Figure 4 shows the statistical significance of the hypothesized relationship and P-values. Table 4 shows the supported and unsupported hypotheses.

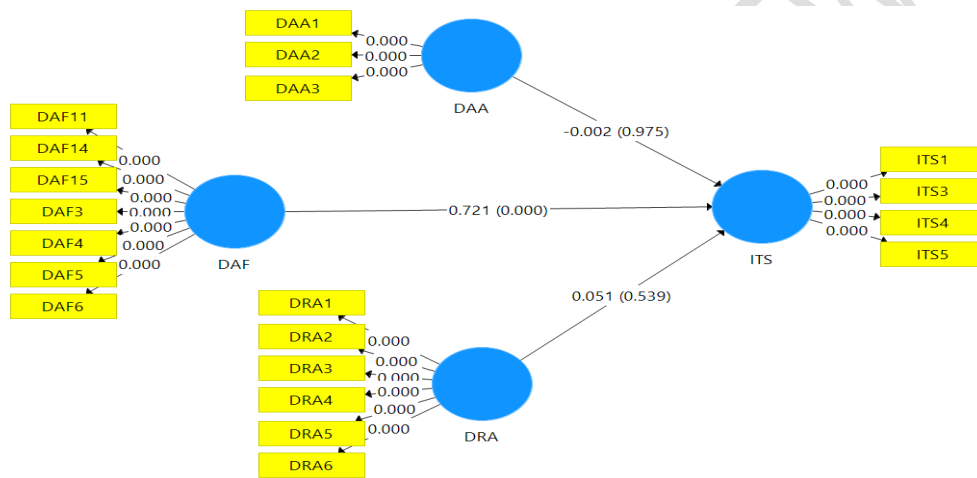

**Figure 4: Statistical significance of the hypothesized relationship**

Source: Author, 2024

**Key:** Departure Airport Accessibility (DAA), Departure Airport Facilities (DAF), Departure Retail Area (DRA), International Tourists Satisfaction (ITS)

**Table 4: The Tested Hypothesis**

	T Statistics ( O/STDEV )	Statistical significance	
		P - Values	Remark
Departure Airport Accessibility (DAA)	0.031	0.975	Unsupported
Departure Airport Facilities (DAF)	8.544	0.000	Supported
Departure Retail Areas (DRA)	0.614	0.539	Unsupported

Source, (2024)

The  $Q^2$  value was higher than zero (0.344), implying that the exogenous constructs can predict the endogenous constructs. The  $R^2$  value for the study was 0.570, which is moderate, implying that the exogenous constructs are influenced by 57% of the variation of endogenous constructs. The result for collinearity statistics values for the inner model was less than 5, implying no multicollinearity problems among the predictor constructs. The study also checked for the relevance of the path coefficient and statistical significance of the hypothesized relationship. The

results disclosed two positive path coefficients for the hypothesized relationships, implying that an increase in one standard deviation increased international tourists' satisfaction, and one relationship had a negative path coefficient, suggesting that an increase in one standard deviation decreases international tourists' satisfaction.

**Table 5: Q<sup>2</sup>, R<sup>2</sup>, F<sup>2</sup> and VIF values**

	Q <sup>2</sup> Values	R <sup>2</sup> Value	f <sup>2</sup> Value	Inner Collinearity Statistics (VIF) values
	Q <sup>2</sup> (=1-SSE/SSO)	(R <sup>2</sup> ) ITS	(f <sup>2</sup> ) ITS	
Departure Airport Accessibility (DAA)			0.000	1.263
Departure Airport Facilities (DAF)			0.616	1.961
Departure Retail Areas (DRA)			0.003	1.839
ITS	0.344	0.570		

Source, Author, (2024)

#### 5.4 Theoretical Implications of the Study Findings

The study adopted three constructs with PCAM indicators, as Wiredje et al. proposed (2019). The adopted construct indicators measured tourists' satisfaction at the airport terminal. More indicators were added to the literature constructs, affecting the actual number of indicators in the PCAM. Thus, the departure non-processing domain has been validated to suit Tanzania airport service performance. Hence, based on Figure 1, the departure airport accessibility has three (03) indicators after validation instead of two (02) indicators before validation, and departure airport facilities have seven (07) indicators after validation instead of six (06) indicators before validation and departure retail areas have six (06) indicators after validation instead of four (04) indicators. Referring to Table 2, five (05) indicators have been added to the departure airport facilities, and three (03) indicators have also been added to the departure retail areas. Figure 5 demonstrates the validated PCAM (see the highlighted sections) compared to Figure 1B with genuine PCAM domain indicators proposed by Wiredje et al. (2019).

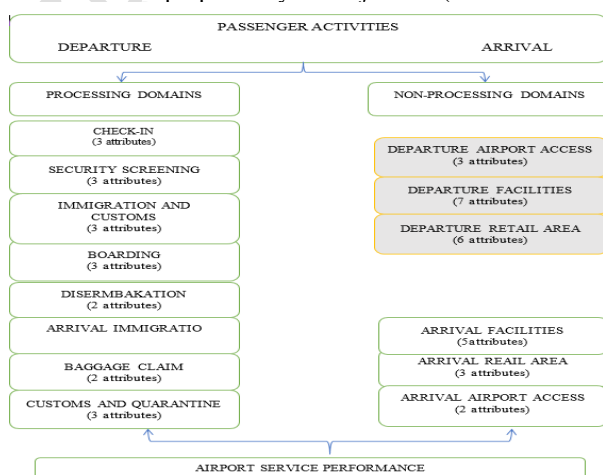

**Figure 5: Validated PCAM**

Source: Wiredje et al. (2019), Researcher, (2024)

## 5. Discussion

Airport arrival retail area, airport arrival facilities, and airport arrival accessibility were hypothesized to have a direct, positive, and significant relationship with international tourist satisfaction. The results revealed that two hypothesized relationships (departure airport accessibility with international tourists' satisfaction and departure retail area with international tourists' satisfaction) were statistically insignificant. This indicates that the relationship between departure retail areas (variety of retail shops and cafes, value for money for the shops and cafes, availability of a variety of food and beverages, clear tourism information, the goodness of restaurant/cafe services, and environment and reasonable COVID-19 precaution and safety protocols) and departure airport accessibility (availability of various transport options from city to town, satisfactory taxi fare and parking facilities and accessible car parking) toward international tourists does not exist in real life. The results for the two relationships contradict the study by Hajez and Fawzy (2021), who showed that airport retail areas, including the reputation of snack bars and restaurants, tend to influence international tourists' satisfaction. Bakir *et al.* (2022) and Bezerra *et al.* (2015) advanced that airport shopping and value for money have little influence on tourists' satisfaction. Airport accessibility services and retail areas were also established to influence international tourists' satisfaction. Studies by Ansari and Agarwal (2020), Putra *et al.* (2021), Phuyal *et al.* (2018), and Olgaec *et al.* (2021) report that airport accessibility and retail area services, counting transfer services, staff attitude and efficiency tend to influence satisfaction. However, a weak direct relationship between public transport options and tourist satisfaction was reported by Adeniran *et al.* (2018).

Airport departure facilities (attractiveness and comfort of the waiting lounges, adequate and comfortable seats, clear information desks, displays and signs, conditions of baggage trolleys, convenient location of baggage trolleys, availability of internet or Wi-Fi, satisfactory boarding calls, cleanliness of the terminal floor, facilities, and public areas, good and comfortable terminal environment and overall terminal comfort) were hypothesized to have a direct and significant relationship with international tourist satisfaction. The results were similar to those from previous studies by Yavuz *et al.* (2021), Venkaiah and Gupta (2015), Prentice and Kadan (2019), Bakir *et al.* (2022), and Aydoğan (2021) and the reference therein. The findings documented by Mwesumo and Halpern (2021) showed that the absence of Wi-Fi at the airport can cause dissatisfaction among tourists. Ansari and Agarwah (2020), Jasrotia *et al.* (2020), Sumanasiri and Dambagola (2020), Bellizzi *et al.* (2018), and Gajewicz *et al.* (2022) revealed that airport cleanliness, physical ambience, airport comfortability, and staff willingness help to promote travellers' satisfaction. However, the findings from descriptive statistics showed that tourists were weakly satisfied with the taxi fares, public transport accessibility, getting clear tourism information, availability of a variety of foods and beverages, children's changing rooms, children's facilities and play areas, value for money at shops and cafes and a variety of retail shops.

## 6. Conclusion

This study assessed the relationship between airport departure non-processing service performance and international tourists' satisfaction. PCAM supported the expectancy disconfirmation theory used in this study to meet the study objectives. From the theory, only two constructs were adopted in this study: perceived performance and satisfaction. The perceived

**Comment [NP8]:** The Discussion and Conclusion sections of the manuscript appear to be appropriate, as they effectively summarize the study findings and offer insightful interpretations and implications.

**Comment [NP9]:** Overall, the manuscript demonstrates adherence to scientific principles and contributes meaningfully to the understanding of airport service performance and its impact on tourist satisfaction.

performance was subdivided into three constructs based on the constructs forming the airport departure non-processing domain in the PCAM. The theory missed airport service indicators. Hence, the study adopted indicators from the PCAM. Other indicators from the literature were added to the construct and statistically tested. The study findings revealed that two hypothesized relationships were not significant, while one hypothesized relationship was significant. Thus, the model was validated to accommodate the added indicators. The study recommends that airport operators should deliberate close and the same monitoring of airport service performance for the significant and insignificant relationships. Service improvement should be made for the weak, satisfying indicators to improve airport service performance.

Additionally, precautions should be taken while offering services to tourists to avoid unnecessary complaints that may cause a loss of repeat tourists. Researchers can extend the model by adding more indicators based on the study area to improve airport service performance. Future studies can integrate local and international tourists in assessing tourists' satisfaction at the airport terminal. Moreover, the study is based on a reflective measurement model. Thus, future research can use the formative measurement model to assess the relationship.

## REFERENCES

- Abdullahi, M., Adesogan A, and Alhaji A, (2018). The economic and social benefits of air transportation to tourism in Nigeria. *International Journal of Social Sciences*. 4: (1), 77-86.
- Adetayo, A.O., Mobolaji, S., and Feyisola, A.O. (2020). Factor analysis of passenger satisfaction at Murtala Muhammed Airport (MMA2). *Aeronautics and Aerospace Open Access Journal*, 4(1), 13-24.
- Adeniran, A.O. and Fadare, S.O. (2018). Relationship between passenger satisfaction and service quality in Murtala Muhammed International Airport, Lagos, Nigeria. *International Journal of Research in Industrial Engineering*. 7: 349-369.
- Amara, O. (2020). *Top Ten Best International Airports in Africa*. Retrieved March 11, 2021, from Answers Africa: <https://answersafrica.com/top-10-best-african-international-airports.html>
- African Airline Association, (2022). *Annual Report*. Nairobi: AFRAA.
- Ansari Z, A and Agarwah, J. (2020). A critical analysis of the passenger's satisfaction with the service quality of the King Abdulaziz International Airport Jeddah, Saudi Arabia. *International Journal of Economics, Commerce and Management*, 3(8), 213-228.
- Bakır, M.; Akan, S.; Özdemir, E.; Nguyen, P.-H.; Tsai, J.-F.; Pham, H.-A. (2022). How to Achieve Passenger Satisfaction in the Airport? Findings from Regression Analysis and Necessary Condition Analysis Approaches through Online Airpor Reviews. *Sustainability*, 14(2151), 1-20.
- Bellizzi, M. G., Eboli, L., Forciniti, C., Mazzulla, G., Grazia, M., Eboli, L., Mazzulla, G. (2018). Science Direct ScienceDirect Air Transport "Passengers' Satisfaction: An Ordered Logit Air Transport" Passengers' Satisfaction: An Ordered Logit Model. *Transportation Research Procedia*, 33, 147–154. <https://doi.org/10.1016/j.trpro.2018.10.087>
- Bezerra, G.C.L., and Gomes, C.F. (2015). The effect of service quality dimensions and passenger characteristics on passenger's overall satisfaction with an airport. *Journal of Air*

**Comment [NP10]:** The references provided cover a wide range of topics related to airport service quality, passenger satisfaction, and tourism, which is suitable for the discussion in the manuscript. However, it's important to ensure that the references are recent and relevant to the topic at hand.

While many of the references are recent, some are older, and it's advisable to prioritize recent studies to ensure that the information is up-to-date and reflects the current state of research in the field. Additionally, we might want to consider including references from reputable journals and academic publishers to strengthen the credibility of the manuscript.

Here are a few suggestions for additional references that you may find relevant:

1. Parasuraman, A., Zeithaml, V. A., & Berry, L. L. (1988). SERVQUAL: A multiple-item scale for measuring consumer perceptions of service quality. *Journal of Retailing*, 64(1), 12-40.
2. Bakır, M., Akan, S., Özdemir, E., Nguyen, P. H., Tsai, J. F., & Pham, H. A. (2022). How to Achieve Passenger Satisfaction in the Airport? Findings from Regression Analysis and Necessary Condition Analysis Approaches through Online Airport Reviews. *Sustainability*, 14(2151), 1-20.
3. Gajewicz, L., Walaszczyk, E., Nadolny, M., & Nowosielski, K. (2022). Criteria of quality assessment of regional airport service week last picture before the COVID-19 pandemic. *Journal of Air Transport Management*, 103, 1-10.
4. Jasrotia, A., Kour, P., & Gupta, S. (2020). Understanding the impact of airport service quality on passengers' revisit intentions amidst the COVID-19 pandemic. *Enlightening Tourism Journal*, 10, 358-386.
5. Mwesiimo, D., & Halpern, N. (2021). Airport Service Quality and Passenger Satisfaction: The Impact of Service Failure on the Likelihood of Promoting an Airport Online. *Research in Transportation Business and Management (RTBM)*, 40.
6. Putra, A. A., Samdin, R., Rianse, U., & Arsyad, L. O. M. N. (2021). Matahora Airport Service Performance Analysis with Importance Performance Analysis...

- Transport Management*, 44-45, 77-81. doi  
<http://dx.doi.org/10.1016/j.jairtraman.2015.03.001>.
- Berthe, A. (2019). AFRAA Air Transport Statistics. Nairobi: AFRAA.
- Benson, A. (2022). *10 best international airports in Africa according to the latest ranking*. Retrieved from Business Insider Africa: <https://africa.businessinsider.com/local/markets/10-best-airports-in-africa-according-to-latest-ranking/9ezcb60>
- Bezerra, G.C.L., and Gomes, C.F. (2015). The effect of service quality dimensions and passenger characteristics on passenger's overall satisfaction with an airport. *Journal of Air Transport Management*, 44-45, 77-81. doi  
<http://dx.doi.org/10.1016/j.jairtraman.2015.03.001>.
- Calderwood, L. A. (2019). *Travel and Tourism Competitiveness Report: Travel and Tourism at a Tipping Point*. Geneva: World and Economic Forum's for Shaping the Future of Mobility.
- Chen, C.F., and Chang, YC., (2012). Meeting the airports. *Journal of tourism management*. (33): 529-536.
- Cheng, K. (2019). Factors Affecting Information System Satisfaction from a Two-dimensional Perspective, *Open Journal of Business Management*, 07(02), 568-596.
- Chi, P.G., Idris, M. and Yusoff, S.O. (2018). Tourism Service Design: Promoting Malaysia's culture through a National Brand in Kuala Lumpur International Airport (KLIA). *International Journal of Academic Research in Business and Social Sciences*, 8, 686-695.
- Chi, J., and Wonmi, B. (2022). Content Analysis of " Passengers' Perceptions of Airport Service Quality: The Case of Honolulu International Airport. *Journal of Risk and Financial Management*, 15(5), 1-19.
- Chi, P.G., Idris, M.Z and Yusoff, S.O.S. (2018). Tourism service design: promoting Malaysia's culture through a national brand in Kuala Lumpur International Airport (KLIA). *International Journal of Academic Research in Business and Social Sciences*, 8(8), 686-695.
- Chuo, C.-C. (2009). A model for the evaluation of airport service quality. *Institution of Civil Engineers (ICE) Publishing journal*, 162 (TR4), 207-2013.
- Correia, A.R., Wirasinghe, S.C., and Barros, A.G. (2008). The overall level of service measures for airport" passengers' terminals. *Journal of Transportation Research*, 42, 330-346.
- Cristina, S. (2017). New Perspectives of the tourism and air travel relationship. *Cactus Tourism Journal*, 15(2), 24-32.
- Eleboda, S. (2017). Appraisal of Passenger Satisfaction with Air. *American Journal of Social Science Research*, 3, 25-34.
- Fisun Y and Atila Y. (2001). The expectancy Disconfirmation paradigm: A critique. *Journal of Hospitality and Tourism Research*, 25, 107-131.
- Gajewicz, L., Walaszczyk, E., Nadolny, M., and Nowosielski, K., (2022). Criteria of quality assessment of regional airport service week last picture before the COVID-19 pandemic. *Journal of Air Transport Management*, 103, 1-10.
- George, B., and Carlos, F.G. (2020). Antecedents and Consequences of passenger satisfaction with the airport. *Journal of Air Transport Management*, 83. doi:10.1016/j.jairtraman.2020.101766
- Gupta, R., and Venkaiah, V. (2018). Airport Passengers: Their Needs and Satisfaction. *SCMS Journal of Indian Management*, 12, 46-57.

- Hajez, M.E., and Fawzy, M.F., (2021). Passenger satisfaction with service quality at Saudi International Airport. *International Journal of Economics, Commerce and Management*, 9, 198-217.
- Ilmu, J., and Volume, E. (2018). The Effect of Air Transportation on Regional Economic Development : Evidence from Indonesia. *Jurnal Ilmu Ekonomi*. 7(1), 45–58.
- Jasrotia, A., Kour, P., and Gupta, S., (2020). Understanding the impact of airport service quality on passengers' revisit intentions amidst the COVID-19 pandemic. *Enlightening Tourism Journal*, 10, 358-386.
- Kinyondo, A and Pellizzo, R., (2020). Socioeconomic Impact of Tourism: The Case of Tanzania. *African Journal of Economic Review*, Volume viii, VIII(II), 239-257.
- Khoshnood, M., and Alaerad, E. (2016). Airport development impact on the sustainable development of the national tourism industry. *The Turkish Journal of Design, Arts and Communication-TOJDAC*, 161-169.
- Kramer, L.S., Bothner, A., and Spiro, M. (2013). *How Airport Measure Customer Service Performance*. Washington D.C.: Transportation Research Board.
- Krishan, M. and Kumar. (2022). A study on air travelers satisfaction of service quality for Jaipur international airport. *Indian Journal of Management and Language*, 2, 25-32. doi:10.54105/ijml.B2050.102222
- Liu, F., Hocquard, S., Fanning, E., Juniac A.D and Gittens, A., (2019). *Aviation Benefits Report*. Geneva, Switzerland: Ait Transport Action Group (ATAG): Aviation Benefits Beyond Border (ABBB).
- Lohmann, G., and Trischler, J., (2018). Monitoring the quality of service at Australia airport: acritical analysis. *Journal of air transport management*, 67, 63-71.
- Lyons, W.E., Lowery, D., DeHoog, R.H (1992) The Politics of Dissatisfaction: Citizens, Services and Urban Institutions, ME Sharpe.
- Maestro, C. (2017). *Top 10 and worst 10 international airports in Africa - Travel - Nairaland*. Retrieved from Nairaland.com website: <https://www.nairaland.com/3622013/top-10-worst-10-international>
- Marchalina, L., and Dewantara, M.H., (2018). Tourists' perception of service quality at Ngurah Rai Airport Post-Eruption. *Journal of Hospitality and Tourism*, 17(1), 17-26.
- McSherry, D. (2017). Best Airports in Africa 2017. Retrieved from Sleeping in Airport: <https://www.sleepinginairports.net/survey/2017-best-airports-africa.htm>
- McSherry, D. (2019). *Best Airports of 2019*. Retrieved March 10, 2021, from Sleeping in Airport: <https://www.sleepinginairports.net/survey/best-airports-2019.htm>
- McSherry, D. (2020). *Kilimanjaro Airport Guide*. Retrieved April 12, 2021, from Sleeping in Airport: <https://www.sleepinginairports.net/guides/kilimanjaro-airport-guide.htm>
- Mwesiumo, D and Halpern N. (2021). Airport Service Quality and Passenger Satisfaction: The Impact of Service Failure on the Likelihood of Promoting an Airport Online. *Research in Transportation Business and Management (RTBM)*, 40. Retrieved from <https://doi.org/10.1016/j.rtbm.2021.100667>
- Nugraha, P. (2017). Analysing Indonesia Air Connectivity Period of 2006-2016. *Journal of the Civil Engineering Forum*, 3, 11-20.
- Oliver, R. (1980). A cognitive model of the antecedents and consequences of satisfaction decisions. *Journal of marketing research*, 17(4), 460-469.

- Ovuorie, T. (2022). *Why Africa is home to the world's worst airport*. Retrieved from Dw.com website: <https://www.dw.com/en/why-africa-is-home-to-the-worlds-worst-airports/a-61433710>
- Pandey, M. (2016). Evaluating the service quality of airports in Thailand using fuzzy multi-criteria decision-making method. *Journal of Air Transport Management*, 57, 241-249.
- Park, Y.W., and Jung, S.Y., (2011). Transfer Passenger' Perceptions of Airport Service Quality: A Case of Study Incheon International Airport. *Journal of International Business Research*.
- Patterson, P., and Johnson, L., (1997). Modeling the determinants of customer satisfaction for business-to-business professional services. *Journal of the academy of marketing science*, 25(1), 4-17.
- Popovic, V., Kraal, B., and Kirk, P.J. (2010). Toward airport Passenger experience models. *Proceedings of 7th International Conference on Design and Emotion*(pp. 4-7). Chicago, Illinois: Spertus Institute.
- Popovic, V., Kraal, B., and Kirk, Philip, J., (2009). Passenger experience in an airport: an activity-centred approach. *IASDR*, (pp. 18-22). COEX, Seoul.
- Poister, T.H., Thomas, J, C. (2011) "The effect of expectations and expectancy confirmation/disconfirmation on motorists' satisfaction with state highways" *Journal of Public Administration Research and Theory*, 21(4), 601-617
- Prebezac, D., Mikulic, J and Barisic, P. (2010). Passenger Perceptions of Airport Service Performance-A three Dimensional Importance-Performance Analysis. *Acta turistica*, 22(2), 131-253.
- Premkumar, G. and Bhattacharjee, A., (2004). Understanding changes in belief and attitude toward information technology usage: A theoretical model and longitudinal test. *MIS Quarterly*, 28, 229-254.
- Prebezac, D., Mikulic, J and Barisic, P. (2010). Passenger Perceptions of Airport Service Performance-A three Dimensional Importance-Performance Analysis. *Acta turistica*, 22(2), 131-253.
- Prentice, C., & Kadan, M. (2019). Journal of Retailing and Consumer Services The role of airport service quality in airport and destination choice. *Journal of Retailing and Consumer Services*, 47(October 2018), 40–48. <https://doi.org/10.1016/j.jretconser.2018.10.006>.
- Putra, A.A., Samdin., Rianse, U., and Arsyad, L.O.M.N. (2021). Matahora Airport Service Performance Analysis with Importance Performance Analysis (IPA) Method. *International Journal of Civil Engineering*, 10(1), 37-50.
- Phuyal, R., and Joshi, N.m. (2018). Travelers' satisfaction with the service quality of Tribhuvan International Airport, Kathmandu. *International Journal of Economic Research*, 15, 725-735
- Rijal, C. (2018). Service efficiency of Nepal airlines: a case study of customer perceived gap analysis of Yeti Airlines. *Nepal Journal of Multidisciplinary Research (NJMR)*, 1, 80-134.
- Ruwan, R. A. (2020). *Tourism After Corona: Impact of COVID-19 Pandemic and Way Forward for Tourism, Hotel and MICE Industry*. Sri Lanka: Doi- 10.13140/rg.2.2.27955.17442
- Ryzin V., and Gregg G. (2006). Testing the expectance disconfirmation model of citizen satisfaction with local government. *Journal of Public Administration research and theory*, 16(4), 599-611.
- Saayman, M. L. (2018). Tourist satisfaction and subjective well-being: An index approach. *International Journal of Tourism and Research*, 1-12.

- Schiebler, V. V. ((2018)). *Advancing Theory of Consumer Satisfaction and Word of Mouth: But so do Performance Expectations*. Bobingen: 196pp.
- Seetanah, B. (2018). Destination satisfaction and revisit intention of tourists : does the quality of airport services matter ?, *XX(X)*, 1–15. <https://doi.org/10.1177/1096348018798446>
- Soshkin, M., and Calderwood, L.U. (2019). *The Travel and Tourism competitiveness*. Geneva: World Economic Forum's Platform.
- Sumanasiri, E.A.G and Dambagolla, D.G.E.K.P. (2020). Passenger satisfaction with the quality of service offered at the Bandaranaike International Airport (BIA). *Asia Journal of Economics, Business and Accounting*, 15(4), 30-45.
- Van Ryzin, G.G (2006) "Testing the expectance disconfirmation model of citizen satisfaction with local government", *Journal of Public Administration Research and Theory*, 16(4),599.
- Van Ryzin,G.G (2013)"Experimental test of the expectance disconfirmation theory of citizen satisfaction" *Journal of Policy Analysis and Management*, 32, 597-614
- Wiredja, D. (2017). Assessment of Airport Service Performance: A Passenger-Centred Model. A dissertation for the award of Doctor of Philosophy at the Queensland University of Technology, Brisbane-Australia: QUT.
- Wiredja, D., Popovic,V., and Blackler,A. (2019). A passenger-centred model in assessing airport service performance. *Journal of Modelling in Management*, 14, 494-520.
- Wattanacharoensil, W. (2019). *Air Transport - A Tourism Perspective* (p. 25). Thailand: Mahidol University.
- Wen,Y.S., Liu, H.T., Chang,W.L., and Lin, T.A. (2008). Building an integrated model of future complaints intentions: The case of Taoyuan International Airport. *Journal of Air Transport Management*. 14: 70-74.
- Wiredja, D., Popovic,V., and Blackler,A. (2019). A passenger-centred model in assessing airport service performance. *Journal of Modelling in Management*, 14, 494-520.
- Wiredja, D. (2017). Assessment of Airport Service Performance: A Passenger-Centred Model. A dissertation for the award of Doctor of Philosophy at the Queensland University of Technology, Brisbane-Australia: QUT.
- Yavuz,N., Ay,E.,Olgaec,S., and Semra,G.A.,. (2021). Tourists' satisfaction with American continent airports. *Journal of Multidisciplinary Academic Tourism*, 6, 89-98
- Smith, K. (2018). *The impact of airport servicescape on passenger satisfaction*. Atlanta, GA: Georgia State University.
- Sumanasiri, E.A.A, and Dambagola, D.G.E.K.P.K.,. (2020). Passenger Satisfaction with the Quality of Service Offered at the Bandaranaike International Airport (BIA). *Asian Journal of Economics, Business and Accounting*, 15, 30-45.
- Tsai,W.H., Hsu,W., and Chou, W.C. (2011). A gap analysis model for improving airport service quality. *A journal of total quality management*, 22(10), 1025-1040.
- Tse,D.K, and Wilton,P.C.,. (1988). 'Models of consumer satisfaction formation: an extension'. *Journal of marketing research*, 25(2), 2014-212.
- Zhang, Y., and Jiang, H. (2016). An assessment of passenger experience at Melbourne airport. *Journal of air transport management*, 54, 88-92.