

Research status and development trend of mechanized sand production process and equipment optimization

Abstract:With the continuous development of engineering construction industry, the demand for sand used in construction is increasing, the traditional natural sand is increasingly in short supply, and the demand for mechanical sand is increasing. The vertical shaft impact sand machine is an important equipment machine in the production process of mechanical sand. The rotor in the vertical shaft impact sand machine is the core part of the normal work of the sand machine. Studying the rotor in the vertical shaft impact sand machine can improve the efficiency and stability of the sand machine in the sand making process. Compared with the research results at home and abroad, the type and research direction of rotor structure are summarized, and the development trend of vertical shaft impact sand making machine is proposed.

*Key words:*Development trendmechanical sand; vertical shaft impact sand making machine; rotor

1.INTRODUCTION:

With the rapid development of China's infrastructure industry, concrete is needed to build Bridges, roads, tunnels, DAMS, buildings, etc., so the demand for concrete increases[1-2]. The main components of concrete contain cement, sand, water and admixtures and admixtures. The source of sand and stone are naturally generated natural sand, and machine sand produced by machine[3]. With the huge increase of the use of concrete, the natural sand is also overmined, which has caused great harm to the natural environment. **Over-mining of natural sand can damage the stability of river channels and the morphology of riverbeds, affecting the natural flow of rivers and ecological balance.** In order to realize the sustainable development of concrete industry, the development and use of mechanism sand is inevitable[4].

Mechanism sand generally refers to the rock particles whose particle size is smaller than 4.5-4.75mm after machine crushing[29-31]. Compared with natural sand, the advantage of mechanism sand is that its fineness modulus can be controlled and utilized artificially through production process, and it can save natural resources through production mechanism sand such as waste rock and tailings[5]. However, the stone powder content of mechanical sand is large, and the firmness of natural sand is poor[6]. Therefore, the quality of mechanical sand directly affects the quality and performance of concrete[7], And The quality of concrete is directly related to the quality of construction[8]. The production process of mechanical sand involves a number of equipment. The production of raw materials are broken through multistage crushing, and then screened by the screening machine, and finally the finished product is obtained through dust removal and sand washing[9].

Vertical shaft impact crusher is the 4-level process equipment of the whole sand making process, is a kind of high efficiency crushing equipment, widely used in mechanical sand, stone, various metallurgical slag and other industries[10]. Its advantage is that it can affect the

quality of the mechanical sand by changing the production parameters of the crusher. The latest vertical shaft impact crushers have significantly reduced energy consumption compared to older machines, and they are driven by electric motors, which reduces environmental pollution. Therefore, this paper analyzes the vertical axis impact crusher, and summarizes the current situation and development trend of research at home and abroad.

2. OPERATIONAL PRINCIPLE

The working principle of vertical shaft impact crusher mainly involves the purpose of material crushing and shaping through a series of physical impact, grinding and grinding. Vertical shaft impact crusher is mainly divided into two forms: "stone beating stone" and "stone beating iron", as shown in Figure 1.

- 1) Material entry: the material first enters the crusher through the incoming hopper. In the structure of the hopper, a wear ring is usually provided to protect the inlet from wear.
- 2) Material distributor: the material separator is installed on the upper part of the vortex crushing chamber, which is responsible for diverting the incoming material. In the "stone stone" model crusher, one part of the material enters the rotor directly through the central feed pipe and is accelerated, while another part of the material enters the vortex crushing chamber through the outside of the rotor. In the stone iron " model crusher all materials directly into the rotor.
- 3) Rotor acceleration: in the stone iron " model of crusher in the material fell into the rotor, the rotor in the guide of the guide plate accelerated cast out, at this time the speed of the material is very large.
- 4) Impact crushing: in the stone while the iron is hot " type of crusher material fell into the rotor after the material from the impeller flow cast out, first with the separator around the material impact, and then impact to the broken cavity lining layer, with the increase of material particles, material will form accumulation on material lining layer, ejection after the material and accumulation material direct collision.
- 5) Discharge: the broken material is finally discharged from the lower part of the crusher to complete the whole crushing process

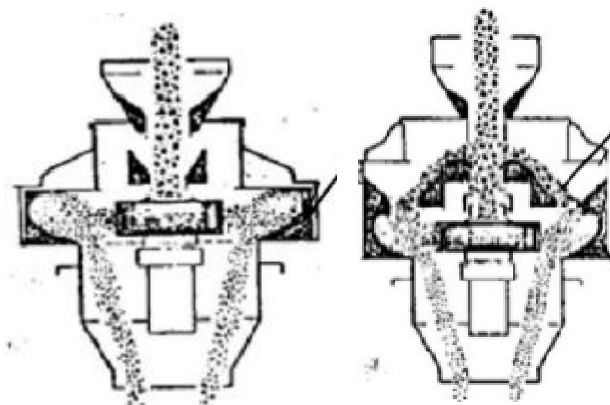

Fig. 1 Working principle of vertical shaft impact crusher

The crushing method of "stone stone" is mainly the collision crushing between materials, which is suitable for materials with hard above and large abrasion. The crushing method of "stone iron" is the metal rotor hammer directly collided with the material, which is suitable for

materials with hard below and less abrasion. Two crushing modes can be selected according to different production requirements and material characteristics to achieve the best crushing effect.

3. CURRENT SITUATION OF OVERSEAS RESEARCH

Vertical shaft impact crushers were studied earlier abroad, which can be traced back to the 1960s. JM uses the rotary cylinder driven by water wheel as the basic structure to realize self-crushing effect[11]. After that, the vertical shaft impact crusher is constantly updated, which represents the mark vertical shaft impact crusher developed by Japan and Britain in New Zealand in the 1980s. This kind of simple structure, light weight and stable operation has been promoted in the 1990s[12].

N Djordjevic[13]The working process and material motion crushing of vertical shaft impact crusher are simulated by using discrete element technology. Using the PFC 3D software, which enables modeling analysis of particle motion and interactions using DEM technology. The crusher was modeled with the PFC discrete metacode. The relationship between particle size and feed position and material dynamic energy is studied. Since the initial impact has an important relationship to the crushing of the whole material, the analysis model of rock crushing in the impact crusher is designed. It is concluded that the initial impact is the important cause of the crushing.

Magnus Bengtsson[14]The experiments were conducted in the laboratory, and the cross experiments were conducted by different rotor speed and feed size. The purpose of the experiment is to establish a model of crusher output and power consumption, which can be effectively used to predict power consumptionMats Lindqvist[15]In the test plant of cone crusher and vertical shaft crusher, it is concluded that vertical shaft impact crusher can save energy effectively.

The above studies are early simple modeling of vertical shaft impact crusher or through actual experiments to test the performance, Emerson Reikdal da Cunha[16]The discrete element method is still used, and the solid flow prediction of the vertical shaft impact crusher under different working conditions is studied. This study uses the discrete element software EDEM, and the results show that DEM can be used to improve the machine design. Juliana Segura-Salazar[17]Through whiten model can effectively predict the material crushing changes caused by changing the crusher process parameters and mechanical structure, using EDEM software for the feeding system material simulation, mainly for the feed speed on material crushing effect, there are two kinds of feed distributor can adjust the feed speed, it is concluded that the feed speed of important influence on the performance of the crusher.

Al -Khasawneh Yaqoub[18]In order to reduce the energy consumption of verticalshaft impact crusher, improve the crushing fineness and improve product quality, study a kind of vertical shaft impact crusher ring armor design and the experiment, mainly for the broken cavity ring armor design, the impact Angle of the collision and tested through the experiment. The test results show that the new design can achieve the best impact Angle in the crushing process, achieve the maximum size reduction effect, and has the energy saving potential of about 8%, which provides a new theoretical and practical basis for the design and optimization of the vertical shaft impact crusher.

BwalyaMurray M[19]Geometric design and simulation setup of the crusher were performed using PFC3D software and Fish programming language. The results of simulating the particles

of different sizes and the single rotor impact crusher at different speeds show that the collision energy distribution of different sizes in single rotor and double rotor is different. In the second rotor significantly improves the crushing performance, especially when the reverse rotation is adopted. The performance of double rotor impact crusher is better than that of single rotor impact crusher under all conditions. Double rotor crusher can increase the crushing efficiency but increase the energy consumption.

4. STATUS QUO OF DOMESTIC RESEARCH

China's vertical shaft impact crusher was developed early, but the early development is relatively slow, and the gap with the international advanced level is obvious[20]. Domestic scholars' research on vertical shaft impact crusher mainly focuses on two aspects. One aspect is to optimize the production process parameters and structural parameters of the crusher by establishing different types of crushing models, and the second aspect is to study the wear of the main parts of the crusher. The main research objectives of both research directions include the most important part rotor of the crusher, and the research of the rotor mainly includes the wear condition and structural parameters of the internal parts.

Feng Gang[21]The mechanical characteristics of material crushing in vertical axis impact crusher are studied, and the energy dissipation is studied based on probability theory. Due to the large number of particles in the whole crushing cavity in the whole material crushing process, which meets the basic requirements of probabilistic science, so the probability theory is applicable to simulate the crushing process. After establishing the corresponding model, the author uses experiments to verify the model, and the results are relatively in line with the model prediction results.

Yong-jie li[22]According to the working principle and actual operating conditions of vertical shaft impact crusher, various factors affecting the effect of vertical shaft impact crushing mechanism sand are analyzed, and the main aspects of crushing mechanism sand process are proposed. The parameters in the production process of crusher mainly include feeding speed, rotor speed, material particle size and material water content. These parameters can affect the working efficiency of the crusher, providing a reference for the subsequent improvement.

Jun-mingzhang[23]Use ADAMS software to analyze the dynamic rotor of the vertical shaft impact crusher, simulate the process of throwing the material from the rotor in the operation of the crusher, and get the maximum impact force and average impact force of the main throwing head in the rotor with the different speed. Because the throwing head is an important part of the rotor, if the throwing head damage will affect the rotor, so the force balance of the throwing head is the key to the rotor can work smoothly, the experimental results show that the rotor speed is the main factors affecting the average force, and the uniformity of the feed grain will affect the quality of the crusher and working conditions.

Duan Derong, Jinan University[24]The material-field analysis method is used to study the material crushing state of the vertical shaft impact crusher, that is, the process of material crushing is to accelerate the material through the centrifugal force generated by the rotor rotation. Material-field analysis of the rotor in the process of accelerating material, adverse effects on material acceleration will cause low speed of the material, the rotor structure limits the material, so in order to improve the ejection speed of the material designed a new type of secondary acceleration rotor, using EDEM software for new rotor, the impact of the rotor

installation Angle for many experiments, determine the appropriate Angle, the results show that the secondary accelerated rotor can effectively accelerate the material.

Zhao Limei, Guizhou University[25]Design the secondary accelerated rotor, for the purpose of the speed of rotor ejection material, to optimize the structure parameters of the secondary accelerated rotor, compared to the previous scholars research, consider more factors affecting the results, including the radius of the rotor, the guide plate Angle, cone Angle, impact plate lag Angle and installation Angle, through orthogonal experiment simulation, regression analysis simulation experiment results get the optimal solution.

Shown is a 3D model diagram of the secondary accelerating rotor.

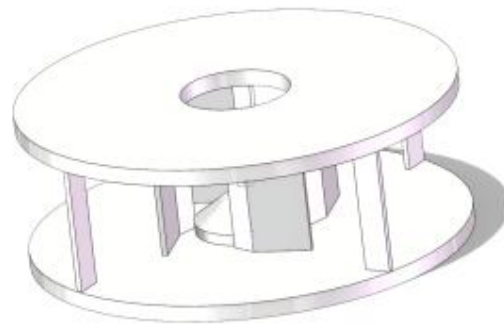

Fig. 2 Secondary accelerated rotor

Liu Daoxiu, Yang Qin, University of Jiangxi University of Science and Technology[26]For vertical shaft impact crusher rotor on the number of study, through the EDEM software simulation analysis, explore the influence of the quantity of crushing performance, the final result guide plate number is 4, the secondary acceleration after the peak material speed, the number of 5, high speed particle ratio increases.

Tao Yin, Huaqiao University[27]EDEM software was used to analyze the stress characteristics of the hammer head in the rotor, including the size and speed of the force on the impact of the hammer head and the surface microscopic appearance, and the hammerhead wear experiment was designed. The experimental results show that optimizing the rotor structural parameters can reduce the hammerhead wear.

Feng Feifei, North China University of Water Resources and Electric Power[28]Taking the wear of part of the material cone in the rotor of the vertical shaft impact crusher as the research goal, the wear degree of the material cone will directly affect the dynamic balance and working efficiency of the rotor as shown in the figure is the material impact of the material cone. The discrete element software EDEM was used to simulate the rotor and analyze the influence of the structural parameters of the rotor and the production parameters of the crusher on the cone wear. The final result is that the wear of the cone can be reduced by optimizing the structural parameters.

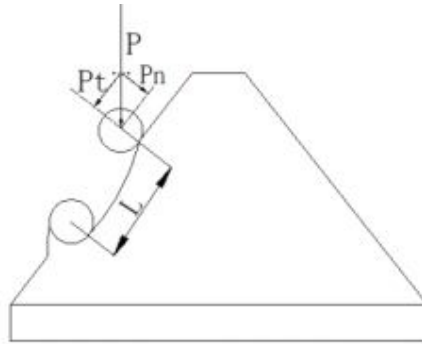

Fig. 3 Schematic diagram of the material impact material separation cone

5. CONCLUSION

With the development of technology and the change of market demand, the vertical shaft impact sand making machine will continue to develop towards a more efficient, more environmentally friendly, more intelligent direction.

FUNDING: Henan 2023 Research and development of key technologies for intelligent distribution of ready-mixed concrete materials and cloud platform system (232102220089)

COMPETING INTERESTS

Authors have declared that they have no known competing financial interests OR non-financial interests OR personal relationships that could have appeared to influence the work reported in this paper.

REFERENCES:

- [1] Radan Tomek. Advantages of Precast Concrete in Highway Infrastructure Construction [J]. Procedia Engineering, 2017, 196: 176-180.
- [2] square sword. Characteristics and research progress of mechanical sand concrete [J]. Anhui Architecture, 2021, 28 (10): 119-121.
- [3] Liu Zhenpeng, Wang Jing, Lu Fang, et al. Overview of the research and application status of mechanical sand and mechanical sand concrete [J]. Heilongjiang Transportation Technology, 2017, 40 (02): 20-21.
- [4] Ge Haosheng, Sun Zhenping, Dong Luxin, and so on. Research on the performance characteristics and application technology of mechanical sand [J]. Concrete World, 2023, (08): 72-81.
- [5] Zhao Xianpeng, Chen Wei, Du Huancheng. Research status of artificial sand and stone aggregate for highway cement concrete [J]. Highway Traffic Technology, 2006, (08): 80-81, 88.
- [6] Chen Fengbin, Liu Jiguang, Jiao Huazhe, et al. Effect of stone powder content on the mixing properties and mechanical properties of mechanical sand concrete [J]. Concrete: 1-8.
- [7] Luo Tingyi, Tingyi Luo, Yasen Tang, et al. Analysis on Research Status of Road Performance of Machine-made Sand Concrete [J]. Iop Conference Series: Earth and Environmental Science, 2020, 587(1): 012036-.

- [8] Huang Li. Factors affecting the quality of ready-mixed concrete and control measures in construction [J]. *Neijiang Science and Technology*, 2024,45 (03): 42-43,156.
- [9] household ning. Comparison and analysis of mechanical sand production machinery [J]. *Construction Machinery*, 2019, (08): 66-68.
- [10] Wang Lihua. Vertical shaft impact crusher VSI [J]. *Construction Machinery*, 2004, (11): 80-81.
- [11] Wu Jianming. Barmac Vertical impact crusher [J]. *Foreign metal ore beneficiation*, 1990, (03): 53-56.
- [12] Qi Guocheng. Research on the crushing mechanism of the vertical impact crusher [J]. *China Building Materials and Equipment*, 1996, (11): 16-21.
- [13] N Djordjevic F N Shi R .D Morrison Applying. . . . discreteelementmodellingtoverticalandhorizontalshaftimpactcrushers [J]. *Minerals Engineering* , 2003, 16(10): 983-991.
- [14] Magnus Bengtsson ,C Magnus. Evertsson Modelling. ofoutputandpowerconsumptioninverticalshaftimpactcrushers [J]. *International Journal of Mineral Processing*, 2008, 88(1): 18-23.
- [15] Mats Lindqvist Energy. considerationsincompressiveandimpactcrushingofrock [J]. *Minerals Engineering* , 2007, 21(9): 631-341.
- [16] Emerson Reikdalda Cunha ,Rodrigo . M deCarvalho ,Lu í sMarcelo . Tavares SimulationofsolidsflowandenergytransferinaverticalshaftimpactcrusherusingDEM [J]. *Minerals Engineering*, 2013, 43-44 85-90.
- [17] Juliana Segura -Salazar, Gabriel Pantoja Barrios ,Victor Rodriguez , et . al Mathematical modeling of a vertical shaft impact crusher using the Whiten model [J]. *Minerals Engineering* 2017, 111(null): 222-228.
- [18] Al -Khasawneh. Yaqoub Development and testing of a novel mathematical -physical model for the design of ring armor for the vertical shaft impact crushers [J]. *Minerals Engineering*, 2021, 170.
- [19] Bwalya Murray M Chimwani Ngonidzashe Numerical. Simulation of a Single and Double -Rotor Impact Crusher Using Discrete Element Method [J]. *Minerals* , 2022, 12(2): 143-143.
- [20] Long Qitao, Zhao Limei, Sun Ke, et al. Deformation analysis and optimization of throwing head of vertical shaft impact crusher based on DEM-FEM [J]. *Non-ferrous metals (mineral processing part)*, 2023, (06): 39-48.
- [21] Feng Gang. Simulation and simulation study of impact crusher [D]. *Liaoning Engineering and Technical University*, 2007
- [22] Li Yongjie, Mao iron cow. Technology and research of vertical shaft impact crushing mechanism sand [J]. *Guizhou Hydroelectric Power Generation*, 2008, (02): 1-5.
- [23] Zhang Junming, Zhao Fang. Rotor load of vertical shaft impact crusher based on ADAMS [J]. *Journal of Coal Science*, 2009,34 (06): 853-856.
- [24] Duan Derong. Flow field analysis of the crushing cavity of the vertical shaft impact crusher [D]. *University of Jinan*, 2012
- [25] Zhao Limei, Zhang Cheng, Xu Lei. Structure design and optimization of secondary acceleration rotor of vertical shaft impact crusher [J]. *Modern Manufacturing Engineering*, 2020, (11): 143-149.
- [26] Liu Daoxiu, Yang Qin, Zhu Xianyun, et al. Study on correlation of guide plate and crushing

- performance of vertical shaft impact crusher [J]. China Tungsten Industry, 2017,32 (02): 65-70.
- [27] Tao Yin. Wear experiment and simulation optimization of impact crushing hammer head [D]. Huaqiao University, 2018
- [28] Feng Feifei. Research and simulation optimization of vertical shaft impact crusher [D]. North China University of Water Resources and Hydropower Power, 2021
- [29] Mohamed MG, Vincent P. Innovative Wind Energy Generating Device Coupled with Air Convergent. Curr. J. Appl. Sci. Technol. [Internet]. 2023 Mar. 14 [cited 2024 May 29]; 42(4):32-44. Available from: <https://journalcjast.com/index.php/CJAST/article/view/4065>
- [30] Verma PD, Verma A, Naik RK, Jogdand SV, Dave AK, Rajput A. Design of Vertical Rotor Metering Plate for Precision Seeding of Okra: Incorporating Physical and Engineering Properties. J. Sci. Res. Rep. [Internet]. 2024 Apr. 18 [cited 2024 May 29]; 30(5):931-8. Available from: <https://journaljsrr.com/index.php/JSRR/article/view/2010>
- [31] Puri V, Chauhan YK, Singh N. A comparative design study and analysis of inner and outer rotor permanent magnet synchronous machine for power generation in vertical axis wind turbine using GSA and GSA-PSO. Sustainable Energy Technologies and Assessments. 2017 Oct 1; 23:136-48.