

Method Article

MODELLING AND OPTIMIZATION OF A BREWERY PLANT FROM STARCH SOURCES USING ASPEN PLUS.

ABSTRACT

The brewing industry faces challenges with the use of malted barley as the primary starch source in Nigeria including quality control and standards, local production and demand, market competition, and price [1]. The challenges of developing new product designs using pilot plants include inherent drawbacks and significant time constraints [2].

This research explores the potential of sorghum as a valuable addition to barley in the brewing industry, especially in semi-arid regions like Africa. This study developed and optimised a model simulated using Aspen Plus for the brewing process, incorporating both malted barley and raw sorghum. Process parameters from Brewery Plant X formed the basis for the model to simulate the entire process from grain to fermented beverage.

The results obtained from material flow analysed revealed significant quantities such as 1417kg/hr of raw sorghum, 937.2kg/hr of malted barley and 8300kg/hr of water as input materials into the mash vessels, yielding 2460.658kg/hr of wort after mash saccharification and wort separation using a mash filter in the wort kettle. The boiled wort is pitched with brewers yeast (*Saccharomyces cerevisiae*) after chilling down to 9°C via a plate heat exchanger. 1321.781 kg/hr of ethanol is produced in the fermentation storage tank during fermentation. Optimisation efforts focused on varying the barley to sorghum ratio, resulted in statistically significant improvements in ethanol yield ($p < 0.0001$). The model's accuracy was confirmed through Box-behnken design and ANOVA, demonstrating strong agreement between actual and simulated ethanol yields. Additionally, pinch analysis facilitated heat exchanger optimization, enhancing energy efficiency and sustainability during the brewing process. Heat exchanged via the plate heat exchanger was charged into the system for sparging process amounting to energy cost saving of 0.34%. The economic analysis underscored the financial viability of the brewing process, with a total capital cost of \$1,133,600.00 and annual operating expenses of \$16,831,800.00. Raw material costs totaled \$14,738,400.00 annually, while product sales generated \$251,082,000.00 per year. Moreover, energy savings were achieved, with low pressure (LP) steam utilization saving \$91 per year and refrigerant use contributing \$46 annually. The desired rate of return for the project is set at 20% per year, with a payback period of 1.5 years. The findings from this study will contribute to the growing body of knowledge in the field of brewing process simulation and modeling and have practical implications for the brewing industry.

Keywords: [Brewing, Aspen Plus, Ethanol, Sorghum, Barley, Optimisation]

1. INTRODUCTION

In times past, barley has been the sole cereal that is used in the production of alcoholic beverages in Western part of Africa and in Nigeria inclusive; this practice has left us in the dependent stage of life, adding no dividend to the economy of the country. Rather it takes from it to expand and enrich others and growing us in the rank of a dependent nation. Recent research works have strived to break that barrier of over dependency by introducing other means of using home grown grains in the

production or manufacture of some of these alcoholic beers and beverages, of which sorghum is part of this innovations [3].

Unlike barley, which is the predominant cereal being used in the brewing industry, sorghum can grow in the semi-arid climatic regions of the world. In Africa, sorghum grain is used to prepare bread, porridge, and beverages both alcoholic and non-alcoholic [4]. Since ancient times, it has been used to produce traditional African opaque beer [5]. Due to a demand for western type clear lagers, much research was carried out in the

1970's and 1980's on the use of sorghum as a brewing material. In 1988 the Nigerian government due to economic reasons, put a ban on the importation of malted barley into Nigeria which affected the use of malted barley in brewing operations[6]. This forced local breweries to look at alternative indigenous cereals such as sorghum and maize as replacements for malted barley.

Traditionally, barley has been the primary starch source for brewing due to its high maltose content and enzymatic potential [7]. Barley contains enzymes called amylases, which naturally break down the starches present in the grain. However, recent developments in the brewing industry have sparked interest in exploring alternative starch sources to diversify the range of flavors and cater to dietary restrictions or preferences. One notable aspect of brewing is the enzymatic breakdown of starches into fermentable sugars. However, different starch sources may require different enzymatic profiles for effective saccharification. For instance, other grains such as sorghum, corn, rice, and wheat may require additional enzyme supplementation to facilitate starch conversion [8].

The use of simulation and modeling, particularly with the aid of Aspen Plus, offers a powerful approach to understanding and optimizing these processes[9]. By exploring the biochemical reactions, engineering operations, and interdependencies involved in brewing, researchers and engineers can develop comprehensive simulation models that provide insights into the effects of different starch sources on product quality, process parameters, and overall brewing efficiency. It's essential to bear in mind that brewing is a multifaceted process impacted by numerous variables. Design Expert, a software used in optimization offers valuable insights, its effectiveness relies on accurate data input and well-founded assumptions. Thus, a solid understanding of brewing principles should complement the software's application.

Pinch technology is a systematic methodology used in process engineering to optimize the energy usage and efficiency of a process [10]. Pinch technology can be effectively applied in brewing operations to optimize

energy usage, enhance heat recovery, and improve resource management. By analyzing temperature profiles, identifying pinch points, and implementing heat integration strategies, brewing processes can be optimized to minimize energy consumption, reduce water usage, and improve overall process efficiency. Implementing pinch technology in brewing operations can contribute to sustainability, cost savings, and environmental impact reduction [11].

The main objective of this study is to develop and optimize a simulation model using Aspen Plus for the complete brewing process, using a mixture of malted barley and raw sorghum to produce fermented beverage.

2. METHODOLOGY

2.1 Process Simulation

Aspen plus was used to model the process in plant X (brewery plant).

The major raw materials are raw sorghum, malted barley, and water. These materials were used in calculating the mass balance, energy balance and process optimization.

Raw sorghum and malted barley characteristics as seen in Table 1 and 2 respectively.

Table 1 Raw sorghum characteristics

ANALYSIS	SPECIFICATION
Appearance	White
Moisture	<= 10% moisture
Yield	75%

Table 2: Malted barley characteristics

ANALYSIS	SPECIFICATION
Appearance	Light brown
Moisture	<= 4.5% moisture
Yield	78.1%

Source: Plant X (2024)

Raw sorghum and malted barley were milled at a fine grind setting of 0.2 mm [12,13]. The milled grains are called grist.

Comment [H1]: More than 20% pilagism observed in introduction it self

The process flow diagram for the Plant X can be seen in Figure 2 below.

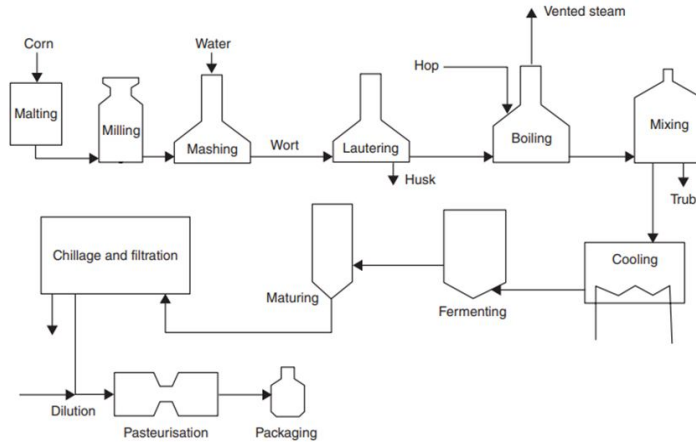
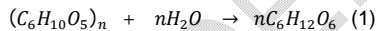

Figure 1: Process Flow Diagram.

2.1.1 MASH CONVERSION

1417.5Kg of raw sorghum grist was mashed in the mash copper vessel with 4800Kg of process water at 50°C to observe protein rest and heated up to 93°C after a 30-minute rest. The mash is cooled down to 75°C via the mash cooler. At heating to 93°C of the mash copper, 937.2kg of malted barley grist was mashed in the mash tun vessel with 3500Kg of process water at 50°C to observe protein rest for 30 minutes. The cooled mash in the mash copper was transferred to the mash tun to achieve saccharification at 66°C for a duration of 20 minutes.

Saccharification is a process where starch breaks down to simple sugar with the aid of alpha and beta amylase. The saccharified mash was mashed off at 78°C for wort separation.



Starch Water Glucose

2.1.2 MASH SEPARATION

The saccharified mash was filtered using a mash filter to produce a clear sugary wort as filtrate and spent grain as residue.

The residue was pressurized to 0.8bar with sparge water at 78°C to extract wort extract trapped in the spent grain. Sparging was done to make the total volume in wort kettle 18000kg.

2.1.3 WORT BOILING

The wort was boiled to 100°C for one (1) hour. The essence of boiling is for wort concentration, sterilization, evaporation, and deactivation of all enzymatic activities. After boiling, the wort was transferred to the whirlpool vessel. The whirlpool stage involves creating a vortex that facilitates the separation of trub (coagulated proteins, hop solids, and other undesirable materials) from the clarified wort.

2.1.4 WORT COOLING

The clarified wort was cooled counter currently from 100°C to 8°C via a two-step plate heat exchanger consisting of ambient water and glycol as coolant. The cooling media is ambient temperature water and glycol at -4°C.

2.1.5 FERMENTATION

The chilled wort was pitched with brewer's yeast (*Saccharomyces cerevisiae*).

The pitched wort was allowed to ferment to 15°C for 10 days and placed on 0°C cooling.

A material balance and energy balance were carried out in the process from mashing to end fermentation using Aspen plus and a comparison was done with all ready gathered data from the modeled plant.

Process parameters was optimized using design expert to improve the final yield of the product.

2.2 Computer Modelling

Simulation Procedure

- i. **Components and Physical Properties:**
 - Aspen Plus uses the Components tab to define water, malt and sorghum any other materials involved in brewing.
 - Appropriate methods for estimating properties and physical properties were selected.
- ii. **Unit Operations:**

- **Mashing:** Mashing is the initial step where crushed malted grains are mixed with hot water in a reactor. This activates enzymes, including α -Amylase, which break down complex starches in the grains into simpler sugars such as maltose and other sugars, creating a sweet liquid known as wort. CSTR Reactor is used to simulate the mashing process where starches are converted to sugars.

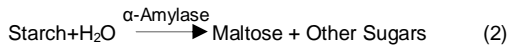

- **Mash filtration:** Filtration involves the separation of liquid wort from the solid spent grains. Remaining starches are further broken down by enzymes, ensuring a thorough extraction of fermentable sugars. The liquid is then transferred to wort kettle, leaving behind the spent grains. A modeled filter is used in the separation of liquid
Reaction: $\text{C}_6\text{H}_{12}\text{O}_6 + \text{Yeast} \rightarrow \text{C}_2\text{H}_5\text{OH} + \text{CO}_2$ (3)

wort from solid spent grains. The spent grain is sparged at a pressure of 800mbar to extract more wort.

- **Boiling:** The wort is brought to a vigorous boil in the wort kettle. Hops are added during the boil. This serves multiple purposes: isomerizing alpha acids in hops for bitterness, sterilizing the wort, and driving off undesired volatile compounds. Additionally, heat promotes the formation of aroma compounds from various precursors present in the wort. During boiling the wort is sterilized, concentrated and evaporated.
- **Fermentation:** After boiling, the wort is rapidly cooled and transferred to a fermentation vessel. Yeast is added, and fermentation begins. Yeast consumes the sugars in the wort, producing alcohol ($\text{C}_2\text{H}_5\text{OH}$) and carbon dioxide (CO_2) as byproducts.

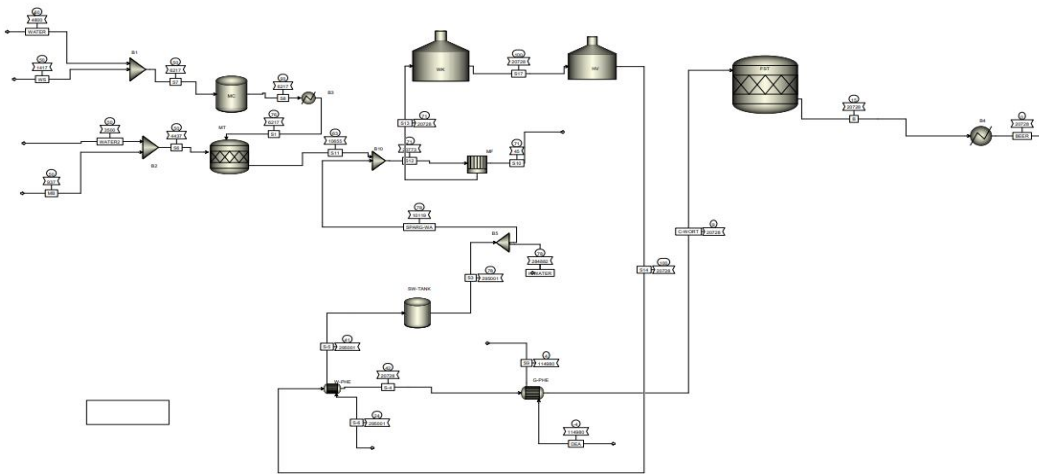

Figure 2: Brewing Process Flowsheet

2.3 Optimisation

Design Expert software was used to create a Box Behnken design that efficiently explores the effects of sorghum and barley proportions on ethanol and CO_2 yield.

Step 1: Determine appropriate factor levels and number of runs based on experimental constraints and resources available.

Step 2: Define Objectives and Variables

- Objective: Optimize the ethanol and CO_2 yield in the brewing process by varying the proportions of sorghum and barley.
- Variables (Factors):
 1. Sorghum content (Factor 1)
 2. Barley content (Factor 2)

Step 3: Conduct Experiment

- Perform the 13 runs according to the Box Behnken design generated by Design Expert.
- Collect data on ethanol and CO_2 yield for each combination of sorghum and barley proportions.

Step 4: Analyze Data

- Input the experimental data into Design Expert software.
- Conduct analysis of variance (ANOVA) to determine the significance of sorghum and barley proportions on ethanol and CO_2 yield.
- Validate assumptions such as normality and homogeneity of variance.

Table 3: Optimised Process Parameters

		Factor 1	Factor 2
Std	Run	A: Sorghum	B: Barley
		kg/hr.	kg/hr.
8	1	1530.55	990.647
13	2	1530.55	824.145
2	3	1648.29	706.41
1	4	1412.82	706.41
7	5	1530.55	657.643
9	6	1530.55	824.145
5	7	1364.05	824.145
6	8	1697.06	824.145
11	9	1530.55	824.145
10	10	1530.55	824.145
3	11	1412.82	941.88
12	12	1530.55	824.145

Table 4 outlines the material mass flow rates at the input and output stages during the mashing process in brewing. The values depict the flow of key components, including water, wort, starch, and glycol, providing insights into the transformations occurring in the mashing phase. The discussion of material mass flow rates during the mashing process aligns with the principles of material balance and process optimization in brewing, as outlined by Box and Draper (2007) and Sims and Evans (2014)[14,15]. Water is input at a rate of 8300 kg/hr and leaves at 8170.495 kg/hr. It facilitates the mashing process and is partially consumed. Wort, which contains sugars extracted from the malt during mashing, is present in the output at 2460.658kg/hr. This indicates wort production during the process. Starch enters at 2354.7 kg/hr and leaves at 23.547 kg/hr, indicating 99.0% saccharification. The utilization of water in the mashing process, as well as the production of wort and the partial consumption of starch, reflects the complex transformations occurring during mashing, as described by Fox (2018) and Narziss and Hahn (2017)[16,17].

4	13	1648.29	941.88
---	----	---------	--------

3. RESULTS AND DISCUSSION

3.1 MODELLING OF BREWING PROCESS

The mass balance calculations were performed using Aspen Plus to track the flow of materials through the brewing process, from mashing to end fermentation. The key inputs and outputs, including raw sorghum, malted barley, water, wort, ethanol, and by-products, were analyzed.

Table 4: Material Mass Flow in and Out Summary in Mashing Process.

MATERIAL	MASS FLOW IN	MASS FLOW OUT
H2O	8300Kg/hr	8170.495 Kg/hr
WORT	0	2460.658Kg/hr
GLUCOSE	0	0
ETHANOL	0	0
CO ₂	0	0
STARCH	2354.7Kg/hr	23.547kg/hr
GLYCOL	0	0

FERMENTATION REACTOR

Table 5: Mass Flow in and Out Summary for Fermentation Process

Mass Flow kg/hr	IN	OUT
H ₂ O	8253.551	8124.331
WORT	2455.259	0
GLUCOSE	0	0
ETHANOL	0	1321.781
CO ₂	0	1262.699
STARCH	0	0
GLYCOL	0	0

Comment [H2]: Please check the format for equation

Table 5 displays the changes brought about by chemical reactions by showing the mass flow of important ingredients during the fermentation process. Wort is introduced and probably consumed in its whole throughout the fermentation process. During the fermentation process, the wort is broken down by the activity of yeast to produce glucose, an essential starting point for the fermentation process. After that, glucose travels through fermentation processes, producing ethanol and carbon dioxide as byproducts. The description of the fermentation process, including the conversion of wort into glucose and subsequent fermentation into ethanol and carbon dioxide, corresponds to established biochemical pathways discussed in works such as Ghosh and Das (2017) and Narziss and Hahn (2019)[18,17].

3.2 PROCESS OPTIMISATION

Design Expert was employed for process optimisation to enhance the final yield of the brewing

process. The experimental design and optimisation aimed to enhance ethanol yield by varying the ratio of barley to sorghum. Table 6 below summarizes the optimised process parameters and their respective impacts on ethanol and CO₂ production rates. The analysis of these parameters provides insights into the relationship between the ratio of barley to sorghum and the resultant yields.

Runs with a sorghum input of 1530.55kg/hr and a barley input of 824.145kg/hr consistently produced the most ethanol, 1415.07kg/hr. This points to an ideal proportion with a high sorghum percentage and a moderately adjusted barley level.

Low barley content (as in Run 5 at 657.643 kg/hr) combined with high sorghum content (1530.55 kg/hr) resulted in a significant fall in ethanol yield to 1255.8 kg/hr. In contrast, raising barley content over the ideal range did not improve ethanol yield correspondingly (e.g., Run 1 with 990.647kg/hr barley generating 1306.79kg/hr ethanol).

Table 6: Optimised Process Parameters.

		Factor 1	Factor 2	Response 1	Response 2
Std	Run	A: Sorghum	B: Barley	Ethanol	CO ₂
		kg/hr	kg/hr	Kg/hr	kg/hr
8	1	1530.55	990.647	1306.79	1248.38
13	2	1530.55	824.145	1415.07	1351.82
2	3	1648.29	706.41	1387.75	1325.72
1	4	1412.82	706.41	1189.81	1136.63
7	5	1530.55	657.643	1255.8	1199.66
9	6	1530.55	824.145	1415.07	1351.82
5	7	1364.05	824.145	1135.14	1084.4
6	8	1697.06	824.145	1415.08	1351.82
11	9	1530.55	824.145	1415.07	1351.82
10	10	1530.55	824.145	1415.07	1351.82
3	11	1412.82	941.88	1255.8	1199.67
12	12	1530.55	824.145	1415.07	1351.82
4	13	1648.29	941.88	1321.78	1262.7

CO₂ production shows a strong correlation with ethanol yield. Higher ethanol yields coincide with higher CO₂ outputs. For example, Runs 2, 6, 9, 10, and 12 all with high ethanol yields (1415.07kg/hr) also have high CO₂ production (1351.82kg/hr). This consistent relationship indicates that the fermentation process efficiency is robust under the optimised conditions, confirming that the variables interact synergistically to maximise both ethanol and CO₂ production.

Runs with lower inputs for both sorghum and barley, such as Run 4 (1412.82kg/hr sorghum and 706.41kg/hr barley), resulted in significantly lower ethanol yields (1189.81kg/hr). This demonstrates the sensitivity of the process to deviations from the identified optimal ratios. Runs with higher sorghum content such as Run 8 (1697.06 kg/hr sorghum and 824.145 kg/hr barley) maintained high ethanol yields (1415.08 kg/hr), suggesting that increasing sorghum beyond 1530.55 kg/hr can sustain high ethanol production as long as barley remains around the optimal level.

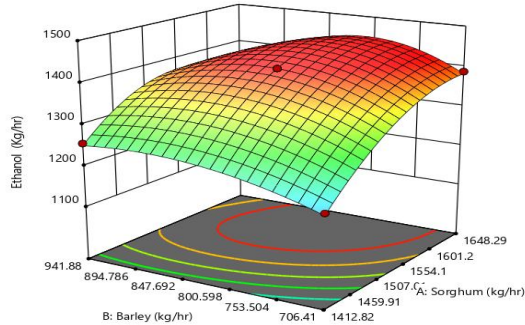

Figure 3: Three-dimensional plot showing the effect of Barley and Sorghum on Ethanol Production.

The Figure 3 above shows the maximum ethanol yield of 1415.07 kg/hr is observed near at the surface graph apex. This point denotes the optimum combination of sorghum to barley inputs that produces the highest rate of ethanol production possible given the parameters of the simulation. Identifying the highest point on the surface graph offers important information on how best to formulate feedstock blends for the manufacturing of ethanol. By selecting the barley (824.145kg/hr) to sorghum (1530.55kg/hr) ratio corresponding to this peak, ethanol yield can be maximised. The data distribution points and the shape of the surface graph display how related barley, sorghum, and ethanol yield are. The differences in ethanol yield across various feedstock compositions are attributed to various factors, including the fermentable sugar content in barley and sorghum, the availability of nutrients, and microbial activity throughout the fermentation process.

Generating standards about feedstock selection and process optimisation is made possible by the 3D surface graph. The 3D surface graph enables decisions regarding feedstock selection and process optimization. By leveraging this knowledge, one can fine-tune operations to achieve higher ethanol yields, reduce production costs, and improve overall process sustainability. Table 7 shows that the P value associated with the model is less than 0.0001, indicating that the cubic model is statistically significant at the 0.05 significance level. P-values less than 0.0500 indicate model terms are significant. In this case A, B, AB, A², B², A²B, AB² are significant model terms. Values greater than 0.1000 indicate the model terms are not significant. The Model F-value of 368.32 implies the model is significant. There is only a 0.01% chance that an F-value this large could occur due to noise. This implies that the observed relationship between barley, sorghum, and ethanol yield is unlikely to be due to random chance, providing strong evidence in support of the model's validity.

Table 7: Model Equation

Source	Sum of Squares	Dif	Mean Square	F-value	p-Value	
Model	1.156E+05	7	16508.39	368.32	< 0.0001	significant
A-Sorghum	39183.20	1	39183.20	874.21	< 0.0001	
B-Barley	1300.19	1	1300.19	29.01	0.0030	
AB	4353.36	1	4353.36	97.13	0.0002	
A²	31541.94	1	31541.94	703.73	< 0.0001	
B²	28709.92	1	28709.92	640.54	< 0.0001	
A²B	649.77	1	649.77	14.50	0.0125	
AB²	2177.17	1	2177.17	48.57	0.0009	
A³	0.0000	0				
B³	0.0000	0				
Residual	224.11	5	44.82			
Lack of Fit	224.11	1	224.11			
Pure Error	0.0000	4	0.0000			
Cor Total	1.158E+05	12				

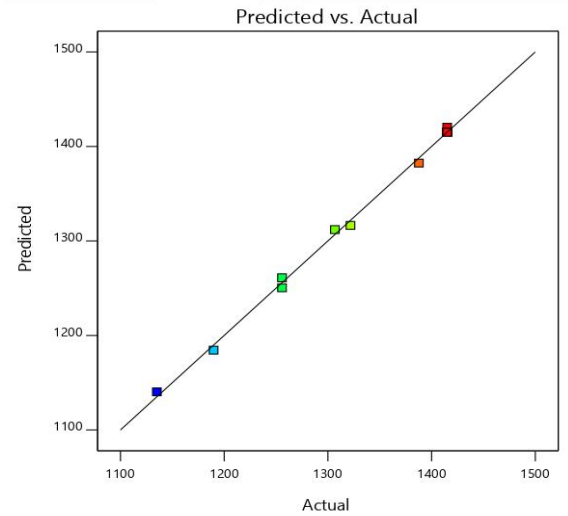

Figure 4: Predicted vs Actual plot.

Figure 4 line plots make the relationship between the actual and predicted ethanol yield levels easier to comprehend. These graph aid in spotting patterns or trends in the data and evaluate the predictive model's overall accuracy.

Table 8: Result of Box behnken Design

Run Order	Actual Value	Predicted Value
1	1306.79	1312.08
2	1415.07	1415.07
3	1387.75	1382.46
4	1189.81	1184.52
5	1255.80	1261.09
6	1415.07	1415.07
7	1135.14	1140.43
8	1415.08	1420.37
9	1415.07	1415.07
10	1415.07	1415.07
11	1255.80	1250.51
12	1415.07	1415.07
13	1321.78	1316.49

Table 8, the dataset consists of 13 simulation runs, each associated with actual and predicted ethanol yield values. These runs represent different combinations of barley and sorghum inputs used in ethanol production simulation. By comparing the actual ethanol yield values with the predicted values, we can assess the performance of the predictive model used in the study. This comparison allows us to evaluate how well the model captures the variation in ethanol yield across different experimental conditions.

Table 9: Design Coefficients Table

	Intercept	A	B	AB	A ²	B ²	A ² B	AB ²
Ethanol	1415.07	98.9737	18.0291	-32.99	-67.3361	-64.2421	-18.0246	-32.9937
P values		< 0.0001	0.0030	0.0002	< 0.0001	< 0.0001	0.0125	0.0009
CO ₂	1351.82	78.7902	8.6138	-31.5152	-64.3266	-61.3706		
P values		< 0.0001	0.2614	0.0159	< 0.0001	< 0.0001		

At the 0.05 significance level, the cubic model is statistically significant, as shown by Table 9's P value, which is less than 0.0001. Strong evidence for the validity of the model is provided by the implication that the observed relationship between barley, sorghum, and ethanol yield is unlikely to be the result of chance. Meyer and Montgomery's (1995) [19] discussion of regression analysis and model validation is consistent with this concept. They illustrated the importance of P values in assessing the statistical significance of regression models, where significant evidence against the null hypothesis is indicated by a P value of .05. Higher values suggest a better fit to the data, and the R² values shown in the table, together with the modified R², are consistent with Meyer and Montgomery's emphasis on evaluating the goodness of fit of regression models. The ANOVA results indicate that the cubic model used to analyze the relationship between barley, sorghum, and ethanol yield provides an excellent fit to the data. The high R² value of 0.9981 suggests that approximately

99.81% of the variation in ethanol yield can be explained by the cubic model. This indicates a strong correlation between the independent variables (barley and raw sorghum) and the dependent variable (ethanol yield). The adjusted R² value of 0.9954 further confirms the goodness of fit of the model. Unlike R², which may increase with the addition of more independent variables, adjusted R² considers the number of predictors in the model, providing a more accurate assessment of model fit. The adjusted R² value of 0.9954 suggests that the cubic model effectively captures the underlying relationship between barley, sorghum, and ethanol yield while minimizing the risk of overfitting. The ANOVA results affirm the reliability and robustness of the cubic model in explaining the variation in ethanol yield as a function of barley and sorghum inputs. The high R² and adjusted R² values, along with the statistically significant P value, underscore the model's effectiveness in capturing the complex relationship between the variables under study.

3.3 ECONOMIC ANALYSIS

The economic analysis provides valuable insights into the financial viability and profitability of the brewing process. The total capital investment required for setting up the brewing process is \$1,133,600.00. This includes costs associated with equipment procurement, infrastructure development, and other capital expenditures essential for establishing the brewery. The annual operating expenses for the brewing process amount to \$16,831,800.00. These expenses encompass various costs incurred during the operation of the brewery, such as labor, maintenance, utilities, raw materials, and administrative overheads. The annual raw materials costs for the brewing process are estimated to be \$14,738,400.00. These costs cover the procurement of essential ingredients such as malt, hops, yeast, and water required for brewing high-quality beer products. The annual revenue generated from the sale of brewing products is \$251,082,000.00. This revenue represents the income generated from selling the brewed products produced by the brewery to consumers, distributors, and retail outlets. The annual utilities costs for operating the brewing process amount to \$4,919.81. These costs include expenses related to electricity, water, steam, and other utilities necessary for the brewing process. The desired rate of return for the brewing process project is set at 20% per year. Additionally, assuming a payback period of 1.5 years, the initial investment in the brewery is expected to be recouped within this timeframe. Based on the data, the economic analysis reveals that the brewing process project is financially viable and profitable. The strong product sales revenue, coupled with relatively manageable operating expenses and raw materials costs, contribute to the project's profitability. The economic analysis supports the decision to invest in the brewing process project. With strong revenue potential, a favorable return on investment, and a relatively short payback period, the project offers attractive prospects for investors seeking profitable opportunities in the brewing industry.

4. CONCLUSION

The study conducted a comprehensive analysis of a brewery plant using Aspen Plus simulation software, focusing on process modeling, mass balance, energy balance, and process optimization. The findings provide valuable insights into the dynamics of brewing operations, highlighting key parameters that influence product quality and process efficiency. The Aspen Plus simulation accurately captured the intricate processes involved in brewing with a final flow rate of ethanol as 1321.781kg/hr and CO₂ as 1262.699kg/hr, from mashing to fermentation. The mass balance analysis revealed the utilisation of raw sorghum and malted barley in achieving the desired wort composition of 2455.259kg/hr, while the energy balance analysis identified opportunities for heat and water recovery and process optimisation using pinch analysis system. The optimisation of process parameters using Design Expert resulted in enhanced product yield. By adjusting feed materials which are barley to sorghum ratio to obtain a maximum ethanol yield of 1415.07kg/hr, the study demonstrated the potential for improving overall process efficiency and resource utilisation. The optimisation process has resulted in substantial improvements in ethanol production performance. By fine-tuning the barley to sorghum ratio, we have achieved higher ethanol concentrations. The utilisation of advanced optimisation algorithms and statistical techniques has ensured the reliability and robustness of the results obtained. The economic analysis provides valuable insights into the financial viability and profitability of the brewing process. The total capital investment required for setting up the brewing process is \$1,133,600.00. This includes costs associated with equipment procurement, infrastructure development, and other capital expenditures essential for establishing the brewery. The annual operating expenses for the brewing process amount to \$16,831,800.00.

Comment [H3]: Economic estimation of final product after and before fortified fermentation can be mentioned

Overall, the study contributes to the growing body of knowledge in brewing process optimization and highlights the importance of utilizing simulation tools for enhancing productivity and sustainability in the brewing industry.

UNDER PEER REVIEW

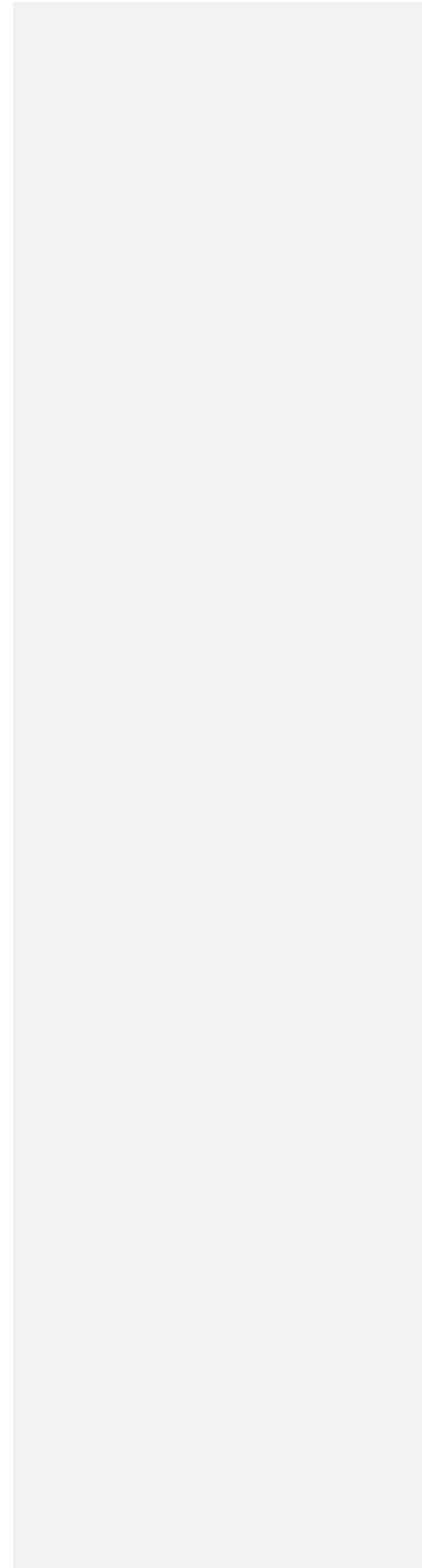

REFERENCES

1. Obilana, T. A., Less known but important cereals in Nigeria: Production processing and their nutritional advantages. Lagos State Polytech. Public Lec. Ser., 2005, 2, 1–27.
2. Bandarapalle, Kishore & Rajasekhar, K.K. & Sri, Kamasani & Neeraja, Boyalapalli & Likhitha, Chejarla & Chaitanya, Krishna & Bhargavi, C. (2024). A comprehensive review on pilot plant scale up and platform technology. Future Journal of Pharmaceuticals and Health Sciences. 4. 14-25. 10.26452/fjphs.v4i1.549.
3. Abah, c. R., ishiwu, c. N. Obiegbona, j. E. And oladejo, a. A. (2020). Sorghum grains: nutritional composition, functional properties, and its food applications european journal of nutrition & food safety, 12(5): 101-111, 2020; article no. Ejnfs.53945
4. Murty, D.S. and Kumar, K.A., (1995). Traditional uses of sorghum and millets. In: Sorghum and Millets, Chemistry and Technology, D.A.V. Dendy Ed., American Association of Cereal Chemists: Minneapolis, pp. 185–222.
5. Daiber, k.h. And taylor, j.r.n. (1995). Opaque beers. In sorghum and millets, chemistry and technology, d.a.v. Dendy ed., american association of cereal chemists: minneapolis, pp. 299-323.
6. Hallgren, I., (1995). Lager beers from sorghum. In: sorghum and millets, chemistry and technology, d.a.v. Dendy ed., american association of cereal chemists: minneapolis, pp. 283-297.
7. Gupta, Mahesh & Abu-Ghannam, Nissreen & Gallagher, Eimear. (2010). Barley for Brewing: Characteristic Changes during Malting, Brewing and Applications of its By-Products. Comprehensive Reviews in Food Science and Food Safety. 9. 318 - 328. 10.1111/j.1541-4337.2010.00112.x.
8. Vitolo, Michele. (2020). Enzymatic modification of starch. World Journal of Pharmacy and Pharmaceutical Sciences. 9. 1341. 10.20959/wjpps20204-15958.
9. Fidan, M. S., Ünal, M., and Görgülü, A. (2019). Modeling and Optimization of Alcoholic Fermentation Process Using Aspen Plus®. Chemical Engineering Communications, 206(12), 1631-1643.
10. Winterbone, Desmond E. (2015). Advanced Thermodynamics for Engineers || Pinch Technology., (), 447–465. doi:10.1016/B978-0-444-63373-6.00019-8.
11. Olajire, Abass A. (2012). The brewing industry and environmental challenges. Journal of Cleaner Production, (), S0959652612001369–. doi: 10.1016/j.jclepro.2012.03.003
12. European Brewery Convention. Analytica EBC, Verlag Hans Carl Getranke-Fachverlag: Nurnberg, 1998.
13. Mitteleuropaischen Brautechnischen Analysenkommission. Brautechnische Analysenmethoden, Selbstverlag der MEBAK, D-85350 Freising – Weihenstephan, 1997.
14. Box, george e. P., & draper, norman r. (2007). Response surface methodology formulation.
15. Sims, G. K., and Evans, R. A. (2014). Dynamic modeling of mashing and fermentation stages of beer production. Industrial and Engineering Chemistry Research, 53(21), 8727- 8734.
16. Fox, Glen. (2018). Starch in Food || Starch in Brewing Applications., 633–659. doi:10.1016/B978-0-08-100868-3.00016-0
17. Narziss, L., Back, W., and Hahn, T. (2019). Mashing. In Brewing Science (pp. 153-183). Wiley VCH Verlag GmbH and Co. KGaA.
18. Ghosh, R., and Das, S. (2017). Optimization of malt-based beer brewing using response surface methodology. Journal of Food Process Engineering, 40(2), e12427.
19. Meyer, Raymond R., & Montgomery, Douglas C. (1995). Response surface methodology: Process and product optimization using designed experiments.

Comment [H4]: More recent references can be included