

Original Research Article

DESIGN AND DEVELOPMENT OF A DOUBLE-LAYER GRAIN SIEVING MACHINE

ABSTRACT

Sieving grains is a fundamental process in the agricultural and food industries, crucial for enhancing the quality and safety of cereal products. However, manual grain sieving results into drudgery, fatigue, and time wastage during the processing. The importance of sieving grains spans several dimensions, including improving grain purity by removing foreign materials and impurities such as stones, dust, and chaff. This process also ensures uniformity in grain size, which is vital for consistent cooking and processing characteristics, thereby enhancing product quality and consumer satisfaction. Additionally, sieving plays a significant role in preventing contamination and ensuring food safety, as it helps in the detection and removal of potential contaminants such as mold, insects, and broken grains. Considering these conditions, there is a need to develop a sieving machine to enhance productivity and reduce drudgery. This paper presents the design of an efficient grain sieving machine that was developed with locally sourced materials for ease of maintenance amongst other design considerations. The machine parts include machine frame, wire mesh, and a vibrator. Several fabrication techniques such as welding, machining, etc. are adopted for the fabrication of the machine. Dry sorghum sample was tested with the machine for operational effectiveness and the result shows that the machine has a sieving capacity of 370kg/hr and sieving efficiency ranging from 85 - 95%. The fabricated double-layered grain sieving machine performed well with high sieving efficiency, reliability, durability with an estimated cost of 400\$.

Keywords: Design, Development, Double-Layered, Grain, Sieving, Machine

INTRODUCTION

The mechanization of grain sieving has revolutionized the agricultural and food processing industries, offering significant advancements in efficiency, precision, and overall grain quality. Utilizing machines for sieving grains ensures a high degree of accuracy in separating particles based on size, which is essential for producing uniform grain products [1]. This mechanized process not only enhances the removal of impurities such as stones, dust, and chaff but also significantly reduces the presence of contaminants like mold, insects, and broken grains, thereby ensuring higher food safety standards. The use of sieving machines boosts productivity by handling large volumes of grain swiftly and consistently, which is critical for meeting the demands of large-scale operations. Additionally, mechanized sieving optimizes resource utilization, minimizes waste, and lowers labor costs, contributing to economic efficiency [2]. The precision offered by these machines also supports better quality control, resulting in superior end-products that meet stringent industry standards and consumer expectations. Ultimately, the adoption of sieving machines in grain processing is a pivotal step towards achieving higher efficiency, improved safety, and sustainable practices in the agricultural sector [3,4].



Fig. 1: Different types of Grains

Economically, sieving contributes to increased efficiency in milling and processing operations by ensuring that only grains of the desired size proceed to the next stages, thus reducing waste and optimizing resource use. Overall, the practice of sieving grains is indispensable in maintaining high standards in the grain supply chain, promoting better health outcomes, and supporting sustainable agricultural practices [5].

Hand sieving is a particle size analysis method that has been practiced for nearly as long as humans. From ancient farmers using simple screens to **separate grains and seeds** to the original gold miners discovering their nuggets, sieving has always been an easy way to separate particles of different sizes.



Fig. 2: Hand Sieving

Mechanized Sieving Technology

Mechanized sieves have been developed to reduce human effort and time in the sieving process. Kudabo et al. (2012) designed and tested a motorized grain sieve powered by an electric motor, with dimensions of 915 mm × 455 mm × 630 mm. The sifter demonstrated an efficiency of 93.3% at a moisture content of 26%, with a sifting speed of 410 rpm and an output capacity of 135 kg/h. Similarly, Jackson and Oladipo (2013) developed a motorized grain sifter at the National Centre for Agricultural Mechanization (NCAM). Their study evaluated the effects of different operating speeds on sifting efficiency. The chosen speeds were 450, 500, 600, and 650 rpm. They recorded the time required to sift a 15 kg laterite sample at each speed. The highest sieving efficiency achieved was 86.5% at 650 rpm, while the lowest was 75.5% at 450 rpm, with an output of 200 kg/h [5]. Suleiman and Adigun (2008) constructed a grain sieve using locally available materials like mild steel and stainless steel. However, they did not perform a comprehensive evaluation of its efficiency and throughput capacity. They recommended using stainless steel for its corrosion resistance and hygienic properties [7].

Orojinmi (1997) also developed a double-layered grain sieve, achieving an efficiency of 76% and an output capacity of 69.12 kg/h. He suggested improvements to enhance efficiency and capacity to make the sieving operation less labor-intensive. Alabi (2009) developed a motorized sieving machine and recommended adding an outlet for unsieved materials, a hopper cover, and a cover for the pulley and electric motor to protect the operator. Comparing the comprehensive studies by Kudabo et al. (2012) and Jackson and Oladipo (2013), Kudabo's machine operated at 410 rpm with a 93.3% efficiency and an output of 135 kg/h. In contrast, Jackson and Oladipo's machine, running at 450 rpm, achieved 75.5% efficiency and an output of 200 kg/h. The discrepancy highlights the need for further investigation into optimal sieve aperture sizes and speeds to balance efficiency and output.

Despite advancements in mechanized sieving, such machines are not yet widely available on the market, unlike grating and sieving operations which have successfully reduced farmers' labor. This indicates that the technology may still require refinement to produce affordable and reliable sieving machines [6,14].

Table 1: Specific Information on Sieving Applications and Advantages

APPLICATIONS OF SIEVING	ADVANTAGES OF SIEVING
<ul style="list-style-type: none"> • In food industries • In Agriculture • In Oil Industries • For domestic purpose 	<ul style="list-style-type: none"> • Getting more output • Required less time • Required less manpower • More reliable • Required less electric consumption • Unit is portable • Technology is simple

AIM OF THE PROJECT

This project aims to develop an efficient Double-Layered Grain Sieving Machine.

OBJECTIVES OF THE PROJECT

The objectives of this project are to:-

- develop an efficient Double-Layered Grain Sieving Machine.
- carry out performance evaluation of the machine developed to determine its functional requirements

JUSTIFICATION

The problems associated with the existing process of Grain sieving are enumerated thus:-

- The old method is extremely time-consuming with little output and labor intensive.
- The cost of buying Imported machines is high.
- Reduced output and efficiency that is associated with the manual methods of sieving

Therefore, the project is to provide an alternative means to the problems highlighted above while still emphasizing the Efficiency of the machine.

MATERIALS AND METHODS

The design of a machine such as the Double-Layered Grain Sieving Machine requires careful consideration of the choice of materials to be used. The materials used for each part were selected based on carefully selected criteria which includes physical and chemical properties of the grain to be sieved, machinability of the material, availability of the material, corrosion resistance and cost

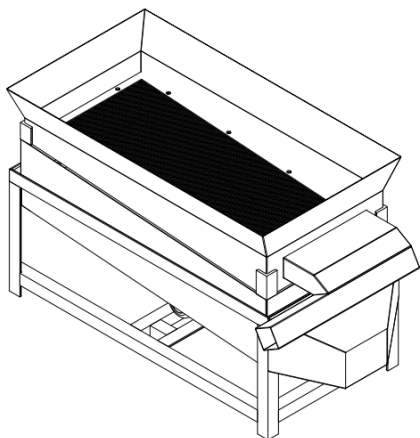

Fig. 3: Model of the Double-Layered Grain Sieving Machine

Design Considerations

The considerations contained in this work are based on the logical necessity of design parameters. The selection of materials for various parts of machine is based on the following factors. The design of the machine was based on the following consideration [10]:

- a. Availability of the materials locally to reduce cost of production
- b. Properties of material to be sieved
- c. Choice of materials
- d. Choice of design for specific parts and selection of some standard parts of the machine
- e. Strength of the material and rigidity of the machine,
- f. Availability of the material locally and ease in obtaining them,
- g. Durability
- h. Corrosion under various uses and weather condition to which its exposed,
- i. Economy/Feasibility
- j. Ease of fabrication, Assembly and Maintenance

Table 2: Materials Selection Procedure

S/N	Machine Component	Criteria for Selection	Most Suitable Materials	Materials actually Selected	Reason for Selection
1.	Sieving Unit	Weight, good wearing property, availability	Mild Steel, Galvanised Steel, Stainless steel	Stainless Steel	Availability and weight, corrosion resistance

2.	Frame (Sieving Unit stand and Diesel Engine stand)	Strength, Ability to withstand impact load/stress, availability, welding ability, machinability, corrosion resistance	Mild Steel, Galvanised Steel, Stainless steel	Stainless Steel	Strength, Ability to withstand impact load/stress and availability, welding ability, corrosion resistance
3.	Collection Chute	Strength, Ability to withstand impact load/stress, availability, welding ability, machinability, Corrosion	Mild Steel, Galvanised Steel, Stainless steel	Stainless Steel	Strength, Ability to withstand impact load/stress and availability, welding ability, corrosion resistance
4.	Angle Iron	Strength, Ability to withstand impact load/stress, availability, welding ability, machinability, Corrosion	Mild Steel, Galvanised Steel, Stainless steel	Stainless Steel	Strength, Ability to withstand impact load/stress and availability, welding ability, corrosion resistance

Concrete Vibrator

A concrete vibrator typically consists of a vibrating head connected to a power unit via a flexible shaft. When the power unit (electric motor, internal combustion engine, or pneumatic motor) is turned on, it drives the vibrating head to produce high-frequency vibrations [8].

The Concrete Vibrator was selected based on the speed and power output required for the machine.

Table 3: Vibrator Specifications

DESCRIPTION	DATA
Model	3hp
Power	1.5kW
Speed	12000Rpm

Machine Features and Description

The Double-layered grain sieving machine as shown in fig. 4 consists of the following component parts; the frame, sieving unit, collection chute and the concrete vibrator. The frame is the main unit of the machine of the machine

on which all other components of the machine are supported. It was fabricated using stainless steel of 2mm thickness to withstand vibration. The angle iron used was firmly joined with arc welding operation. The sieving unit was made of stainless steel angle iron and covered with stainless steel plates so as to form the different layers of the sieving operation. The collection chute was also made of stainless steel and projected at an angle 45° to the horizontal, for easy discharge of the sieved grain through the outlet. The concrete vibrator is placed under the machine on a linear angle iron so that the vibration can be even spread through the whole machine

Working Principle of the Machine Operation

Generally, this sieving machine works by a continuous shaking operation that ensures that particles are shaken therefore compelling them to pass through a specific diameter of mesh which ensures that the bigger diameter of grain does not pass into the second layer of mesh for onward transmission to the grain collection chute. In the case of this mechanism, the motion of the whole machine is obtained from the high-frequency vibrations generated by the concrete vibrator.

When the concrete vibrator is electrically powered on, it produces high-frequency vibration (linear and rotational) which is also transferred to the whole machine thereby causing the grain in the upper layer of the sieving machine to be engaged for sieving before going through the bottom layer for another process of sieving. This double-layered grain sieving machine ensures more efficiency and finer grain at the collection point.



Fig. 4: Fabricated Double-Layered Grain Sieving Machine

PERFORMANCE EVALUATION

In the dry sieve analysis, a suitable quantity of **Sorghum** with a known weight is taken and sieved through the different layers of sieve and subject to a vibration motion generated by the Concrete Vibrator. The amount of shaking depends on the shape and number of particles [11,12]

The machine was tested using a 1.5kW, 12000 rpm vibrator at 15kg loading rate each time. The quantity of laterite was weighed on the balance and weight was recorded. This was poured into the sieving unit and properly spread out. The machine was operated until the sorghum grain was sieved leaving unsieved residue. The time taken was noted and recorded. Also, the sample collected (sand) from the sieve and the sieved residue were weighed and recorded. Please note that the results below are obtained as an average of the two sieving channels. This procedure was repeated for three different times. The performance criteria tested for, were;

- a. Sieving capacity (SC), and
- b. Sieving efficiency (SE).

Sieving Capacity (SC): The sieving capacity is the rate at which the machine sieves in kilogram per hour and this was calculated as;

$$SC = \frac{M}{t}$$

Where;

SC = Sieving Capacity (*kg/hr*)

M = Average mass of grain loaded into the sieve (kg)

T = Average time taken to complete the sieving (hr.)

Table 4: Result of Tests carried out on the Double-Layered Grain Sieving Machine

Trials/Test	Mass of sorghum grain loaded on the machine (kg)	Mass of sorghum grain sieved by the machine (kg)	Time spent (Seconds)
1.	25.00	23.70	3.70
2.	30.00	27.13	4.80
3.	35.00	33.30	5.30
4.	40.00	36.15	5.60

Considering the results obtained from the performance of the machine, the capacity of the machine (SC) is obtained as follows;

$$S_c = \frac{M}{t}$$

$$S_c = \frac{120.28}{19.40}$$

$$S_c = 6.17 \text{ kg/min} \cong 6.20 \text{ kg/min}$$

This means this machine has the capacity of processing 370kg/hr of grain which makes it a good machine for usage.

Sieving Efficiency (S_E): This is defined as the ratio of average mass of sieved sorghum grain sand to the average mass of sorghum grain loaded to the machine and is calculated as;

$$S_E = \frac{\text{Average Mass of Sieved Sorghum Grain}}{\text{Average Mass of loaded sorghum grain}}$$

Where; $SE =$ sieving efficiency

Average mass of sieved sorghum grain = 14kg

Average mass of loaded sorghum grain = 15kg

$$S_E = \frac{14.0}{15} = 93.3\%$$

$$S_E = 93.3\%$$

CONCLUSION

A double-layered grain sieving machine was developed and tested. Based on the results of the performance evaluation, it can be concluded that mechanical sieving of grains can be done more conveniently than traditional methods with a higher sieving efficiency. The machine performed satisfactorily with a sieving efficiency of 93.3% efficiency and 370kg/hr sieving capacity. The choice of locally available material for the construction of the machine makes it suitable for adoption in food industry, and the estimated unit cost is 400\$ as at June 2024.

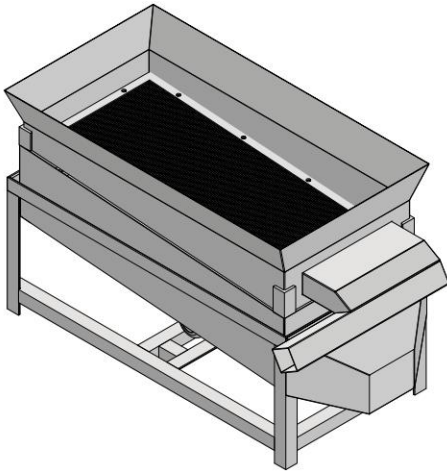

Fig. 5: Model of the Double-Layered Grain Sieving Machine

(Software: Autodesk Inventor)

2.1 REFERENCES

1. Abubakar, M. Abubakar, B. H, Kastina, C. B., Abdulkarim & Seiving Machine for Dewatered Grated Cassava, American J. Eng. Research, 4(2), 146-152.
2. Adamson, D. (2010). Towards building sustainable materials future Journal of Inclusive Scholarship and Pedagogy. Vol.58, pp. 531-4.
3. Adejugbe I. T, Olowonubi J. A, et al. "Design and Development of a Low-Cost Laterite Sieving Machine", Physical Science International Journal. 2022;26(6):29-38
4. Adejugbe I. T, Oyegunwa, O. A, et al. "Design and Development of a Sorghum Winnowing Machine", Journal of Engineering ZResearch and Reports. 2023;25(10):40-46
5. Adejugbe I. T, Olowonubi J. A, et al. "Design and Development of a Low-Cost Hammer Machine for Food Processing", Physical Science International Journal. 2023;27(3):16-26
6. Adzimah SK, Gbadam EK, 2009. Modification of the designs of cassava grating and cassava dough pressing machines into a single automated unit. European J Sci Res, 38(2):306-314.

7. Alabi, O. O. (2009). "Design, Fabrication and Performance Evaluation of a Cassava Lump Breaking and Sieving Machine", An unpublished HND project. Department of Agricultural and Water Resources, Kwara State Polytechnic Ilorin, Kwara State.
8. Bazeley, P. (2011). Issues in mixing qualitative and quantitative approaches to research. International conference qualitative research in marketing and management. University of economics and business administration. Vienna. Pp. 256- 287.
9. Dai, D. Dan., Dai. Xiuying, Tang. (2006). Transitioning towards sustainable materials management of building materials in China. Master thesis submitted for completion of Strategic Leadership towards Sustainability. Blekinge, Institute of Technology, Karlskrona, Sweden.
10. Design, Construction and performance evaluation of a horizontal sand sieving machine and heating machine (Eyere Emagbetere et al. / Advances in Engineering Design Technology : 3, 2021 pp. 86-97)
11. Kudabo EA, Onipede EA, Adegbenro OA, 2012. Design, fabrication and performance evaluation of an improved cassava mash sifter. J Agric Vet Sci, 4:53-64.
12. Legget, D. (2011) Enhancing sustainable materials through generational awareness. Journal of facilities management, 9(2), 145–152.
13. Oladeji Akanni Olawale, "Design, Construction and Testing of a Dry Sand Sieving Machine", Department of Mechanical Engineering, Federal University of Technology, Minna, Nigeria, J. Appl. Sci. Environ. Manage.
14. Oluwole OB, Olatunji OO, Odunfa SA, 2004. A process technology for conversion of dried cassava chips into gari. Nig Food J, 22:65-7
15. Ujam, A.J. And Enebe, K.O. (2013) Experimental Analysis Of particle Size Distribution Using Electromagnetic Sieve, American J. Eng. Research, 2(10), 77-85.