

IoT-based Facial Recognition Door Lock with Push Button Combination

ABSTRACT

A common issue in many households is the management of door keys, which can often be lost, damaged, or forgotten. This problem can be particularly frustrating when family members arrive home to find they cannot enter their residence. One potential solution to this problem is the implementation of a facial recognition system, which can be used by multiple family members to gain access to their home. The proposed system utilizes an intelligent minicomputer with a dual function, serving as both a Central Processing Unit (CPU) and a monitor screen display connected via an HDMI to VGA adapter. Additionally, the system incorporates a RealVNC Viewer (Virtual Network Computer) as a remote desktop application, accessible via a laptop or Android device. The primary aim of this research is to develop a facial recognition system that can unlock a house door by detecting and matching the user's face with stored data. The minicomputer, acting as a microcontroller, captures the user's face through a camera and compares it with the photo database. If a match is found, the system grants access and displays information on the Android device, indicating whether the user is known or unknown. This study employs a Research and Development (R&D) approach to enhance the effectiveness and security of home control systems using an internet network and Android devices. The system successfully detects facial objects within the camera's range, with the detection point area turning left, right, or focusing towards the front of the rectangular frame. The buzzer indicator sounds when the door lock is open. The system has been tested with multiple users, with local detection distance and over a well-validated network.

Keywords: *Face recognition, Intelligent Computers, R&D, Door, RealVNC, IoT, Android.*

INTRODUCTION

The development of computer technology in the era of the industrial revolution 4.0 has had a positive impact on people's lives to adapt and take advantage of the ready availability of technological functions. Many people's busy lives sometimes forget about home security issues in their neighbors' environments. Community environments that appear quiet sometimes become targets for thieves to carry out their actions and their evil intentions are caused by the need for life and weak faith in the soul. Theft that often occurs as a polemic in the midst of life is anxiety about house doors being broken into which results in the loss of valuables. The main target that could occur is an empty house left by the owner due to work activities in an office far from their home. Even though the door is locked with a padlock or even with CCTV installed, it is still ignored and does not have a deterrent effect. There are various methods used by home owners to keep their homes safe from disturbances, especially the arrival of unknown people with bad intentions, they are even guarded by security but the perpetrators manipulate themselves by pretending to be good people, other people think they are the home owner's family.

The steps taken by researchers to resolve this polemic in line with technological developments are to create innovations by designing tools using technology to replace physical manual keys with non-physical digital-based keys and intelligence using facial detection to unlock doors. Facial recognition of certain people can unlock doors so it is considered safer because it is not easily duplicated, not damaged, let alone lost [15,16]. In principle, there has been a lot of previous research in designing a tool to open a house door, but what is different in this research is that technically the lock device uses a solenoid installed embedded in the inside of the frame in a more challenging position but can provide a solution.[2],[3]-[4]. Meanwhile, to open the door from the inside, a push button with the ON (active) function is used so that the user can quickly press the Push On button if they want to go out or there are guests who want to come in. The current use of digital systems is not limited to the fields of education, transportation, business industry and others, but in societal systems technology is also put to good use. Tools designed for real-time storage systems are stored in a database in image format that can be viewed under certain conditions if damage or traces of theft occur. Storage in image format has a greater storage capacity than using an SD card which is stored in the cloud using the Firebase program[5,17-20].

RealVNC (Virtual Network Computing) is an application used to control remote computers and allow users to access other computers connected to the network[6]. Monitoring the situation of the house at any time can be controlled via Android by using the RealVNC application, you can easily see remotely the people who come in front of the house who are detected by the camera, you can remotely view it via an internet connection.[7]. Raspberry Pi in the modern context meets the requirements of being said to be a minicomputer that has many roles, namely centralized control that controls all components connected in a

series of intelligent computer systems connected to a camera, can detect and validate objects, can distinguish between users who have access rights and those who do not have access to open House door. A minicomputer is a device that functions like a computer or laptop in general which is connected to a monitor or projector using a VGA to HDMI cable so that it is multifunctional, not limited to a control system but is suitable for presentations in all fields of education, industry, transportation and business, especially in the world of information Technology.

Raspberry Pi

Raspberry Pi is a type of mini computer consisting of a circuit board that is designed to be an affordable device that can be accessed by many people. Raspberry Pi has computing capabilities capable of running operating systems such as Linux and is capable of running various types of software. Raspberry Pi is equipped with various input and output ports almost the same as computers in general, namely having GPIO (General Purpose Input Output) including USB ports for keyboard, mouse, camera, HDMI, RAM, Ethernet, as well as data storage and the operating system does not use a hard disk drive but rather uses Micro SD with capacities of 2, 4, and 8 GB. Meanwhile, the power source uses original Micro USB power with a power source of 5V and a minimum current of 3A or 4A[8],[9]. Raspberry Pi is not just a piece of hardware but includes a large community of users sharing knowledge, learning projects, internet of Things development, research innovation, industry and others interested in the world of programming and technology. Raspberry Pi 4 model B is shown in the image below.

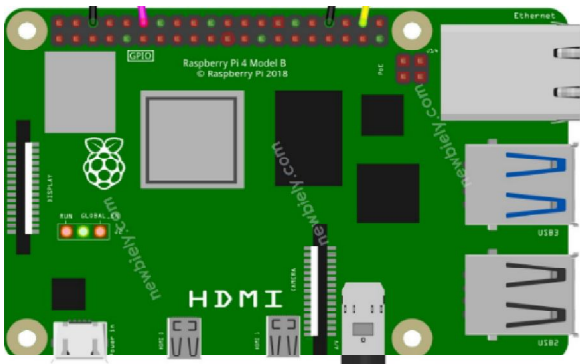

Figure 1. Raspberry Pi

Source: <https://newbiely.com/tutorials/raspberry-pi/raspberry-pi-solenoid-lock>

OpenCV

Open Source (Computer Vision Library) is software that is widely used for real-time digital image and video processing. Computer vision is a part of informatics techniques that supports computers to see objects in the surrounding environment. The purpose of seeing or detecting the object in question is that the computer can analyze the image and convert the data into commands. Computer vision enables machines to recognize and analyze observed objects in the same way humans do. Computer Vision uses a computer to process images or images captured by a recording device, namely a camera or webcam, which are converted from analog to digital and then processed in a computer system. Image processing in OpenCV is intended to read, verify images or improve image quality. This field of research investigates how computers can recognize observed objects so that when combined with Artificial Intelligence (AI), they will be able to create a visual intelligence system that can monitor remotely with an Internet network connection. The programming language used in image processing in OpenCV is Python because Python's ability to process images is limited so it is very necessary to import the library from OpenCV[10].

The application of OpenCV using the Python programming language is a camera installed on a door to detect facial objects (faces) which will be converted from analog to digital into binary data that can be used as information.

The OpenCV installation process is shown in figure 2 below.

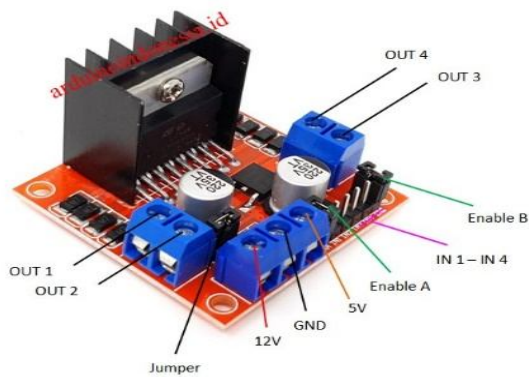

Figure 4. L298N Motor Driver

Source: <https://www.arduinoindonesia.id/2022/10/driver-motor-l298n.html>

1. Pin Out; is a pin that is used to connect to the motor pole. This pin does not have a negative positive pole so the cable can be installed in reverse.
2. Pin In; is a pin that is connected to the Raspberry Pi digital pin. This pin is used to control the direction of rotation of the motor connected to the L298N driver. For example, if IN 1 High and IN 2 Low, then the motor rotates clockwise, but if IN 1 Low and IN 2 High, then the motor rotates counterclockwise. Meanwhile, the Low and High logic values on the IN pin are set in the Raspberry Pi coding using the Python programming language.
3. Pin Enable; The enable pin is a pin that is used as an additional voltage source for a DC motor so that the motor speed is stronger, that is, if it is connected to a 12V voltage to the enable pin, the motor speed will increase so that the solenoid system works faster when pushing and pulling.

The L298N motor driver circuit diagram is as follows:

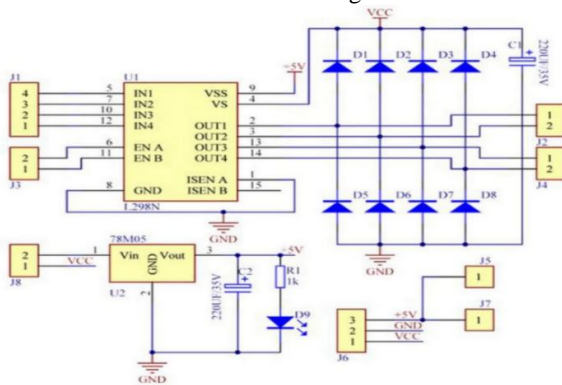

Figure 5. L298N Motor Driver Circuit Diagram

Source: <https://www.mahirelektro.com/2020/02/tutorial-using-driver-motor-l298n->

Solenoid

Generally, houses use conventional door locks which are used to pull and push the latch, the operation is done manually. The current development of digital technology, one of the technologies that can be used in home security situations is using a solenoid door lock, which is an electronic device that functions as an automatic door lock. Modern high-tech life challenges researchers and academics to develop conventional systems towards intelligent systems based on the Raspberry Pi. Door locks with an automatic system apply and use a solenoid lock by providing a low voltage of 12V which is able to pull and push the iron core tongue (plunger, tongue) quickly to open or lock the door when an electric current is applied and receive interrupts or program commands sent via the motor driver as the driving force. The following types of solenoids are often used in designing automatic door locks with electronic systems.



Figure 6. Solenoid Lock

Source: <https://newbiely.com/tutorials/raspberry-pi/raspberry-pi-solenoid-lock>

USB Webcam Camera

Web Camera is a tool in the form of a digital camera that is connected to a Raspberry Pi via a USB port with a Wifi internet network. Web Camera is a type of camera that consists of a lens, a circuit board connected to electronic components that function to capture or take images. In the current digital era, the webcam in this article is used as a camera that detects objects and then processes them with image processing which is displayed with open-Computer Vision support. The results of the image processing displayed on OpenCV can be viewed via a computer or Android device via an internet network with coverage wherever you are as long as internet access is smooth. The webcam used is as in Figure 4 below.



Figure 7. Web Camera

The camera working system is described as follows:

1. Capture photos or videos detected with internet coverage connected to a Raspberry Pi device with a lighting system.
2. It has a light capture system, a camera lens mounted on a microchip with Charge Couple Device (CCD) technology as an image receiver.
3. The captured photos received can be processed by image processing so that they can be viewed remotely using the internet network.

Push Button (On)

A push button switch (Push Button) is a simple device that functions to connect or disconnect the flow of electric current with the working principle being press unlock or not lock. This button is used in designing research tools to open the door from the inside when guests or family want to leave by pressing the Push On button. The push button working system in the design of the tool is that when the button is pressed it means the system will connect an electric current and the tongue (iron core tongue) of the solenoid opens. The type of push button used is as in the image below. This push button has been modified to open the Of valve so that the switch position is always in the NC (Normal Close) state. The solenoid lock is locked and will open when pressed.



Figure 8. Push Button

Source: <https://rakhman.net/electrical-id/push-button/>

Buzzers

The buzzer is an electronic audio signal device which functions to convert audio signals into sound after receiving a DC current voltage which is used in setting up the Raspberry Pi device as a tool design carried out in this research. This mechanism will make a sound when the device is turned on and indicates that the active Raspberry Pi components are ready to work together with other components.



Figure 9. Buzzer

Source: <https://www.elprocus.com/buzzer-working-applications/>

RESEARCH METHODOLOGY

Hardware Design

The research method used is Research and Development (R&D) to develop a smart home security lock system. The research produces a smart key product that can open doors with face detection and remote control which is implemented in the design of a smart lock with a door model that can be opened remotely via Android. If an object or person is detected that is not the owner of the house, then the object can be monitored and then the application sends data to Firebase as information and stored in the data base in a cloud integrated with IoT with Raspberry Pi devices. The door opening system design scheme created in this research is shown in the image below.

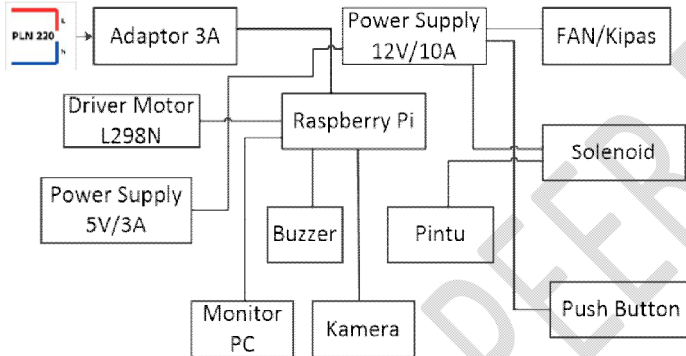

Figure 10. Tool Design Scheme

The hardware design scheme in Figure 9 shows the relationship of all components that are connected in one integrated system. The schematic illustrates the relationship between one another starting from the 220V electrical energy source, then the 3A HP charger adapter, the input voltage source is connected to the Raspberry Pi with a micro USB connector. Next, the incoming current is connected to a 5V/10A power supply which is connected to other components and is also connected directly to the 12V/10A power supply. Current flows to the 12 volt solenoid to actuate the push and pull of the tongue lock on the solenoid. The results of designing a tool to open doors using face detection are as shown in the image below:



Figure 11. Tool Design Process



Figure 12. Tool Design Results

Software Design

Research & Development research is development research using the SDLC (Software Development Life Cycle) model approach, which is a process of developing software systems. Development of frequently used software according to the study. The model approach used in designing intelligent lock systems is the Waterfall model, often called the linear sequential model.[1],[12].

The waterfall model is used with strong considerations based on the needs and appropriate stages according to development as shown in the following image.

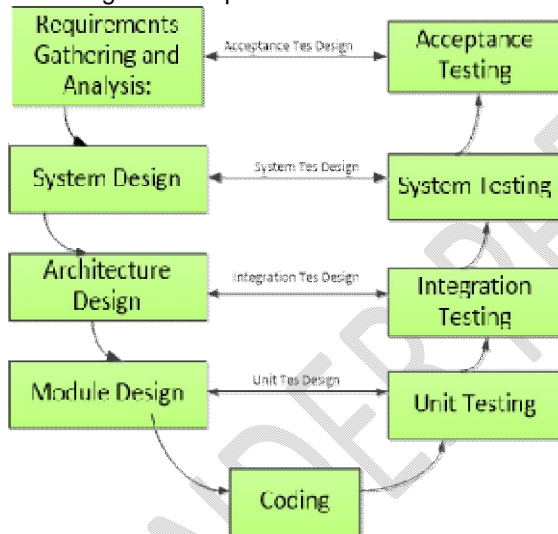

Figure 13. Waterfall Model

1. Requirements gathering and analysis.

Requirements gathering and analysis phase, where gathering requirements for the software is carried out and analyzed to determine the scope of the tool design project with all required components.

2. Design.

The design, architecture and software design phases were developed in detail both in terms of hardware and software using the Python programming language with data base storage design using Firebase.

3. Implementation.

The software implementation stage is built based on designs used in the community to maintain home security and provide information that is monitored remotely. Unlocking the door with facial detection is easy, practical and effective and there is no loss of key, forgetting or damage because every user has the key from the test data and test data.

4. Testing.

In the testing phase, the software is carried out to ensure that it meets customer requirements and is of high quality. Testing is carried out several times to obtain the level of accuracy and reading of the data set and test data on the object to be tested.

5. Deployments.

The deployment phase of the software is distributed and put into use, how to introduce it to the public so that it becomes attractive for use and believe that this tool can make it easier for users as home owners to open the door of the house and maintain security in terms of monitoring or remote monitoring systems.

6. Maintenance.

In the maintenance phase the software is maintained to ensure that it continues to meet user needs and expectations effectively and flexibly.

System Flowchart

The system flowchar is a diagram that depicts how the tool works to retrieve and match user data sets to open doors with facial recognition. The stages are as in the following flowchart.

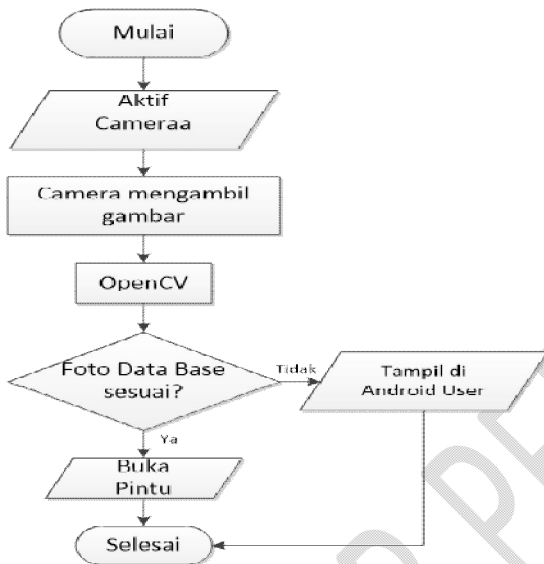

Figure 14. Flowchart of the facial recognition system

RESEARCH RESULTS AND DISCUSSION

Research result

The research results show the system and workflow of the tool for detecting objects in its use to unlock house doors by recognizing a person's face. The results of the tool design are implemented in the use of doors which are not limited to house doors but can be used anywhere, including offices and others that anticipate and maintain security in creating a safe and calm situation and environment. The flow of tool design results is shown in Figure 13 below.

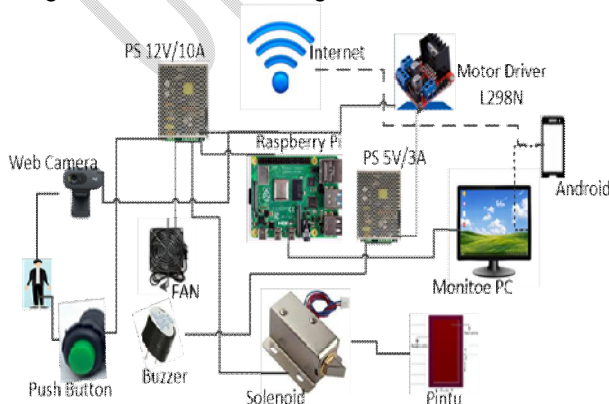

Figure 15. Scheme of tool design results

Based on Figure 13, the next step is to install tools on doors that have been made in real life in a community environment according to standard sizes. The complete design tool is installed on the inside of the door and is connected to a front camera used to detect faces every time an object is detected. Next, the solenoid is connected to a 12V Power Supply and works actively when electrical power is supplied with the buzzer indicator making a sound as a sign that the Raspberry Pi is active. The door design and tools are as follows.



Figure 16. Inside view of the device in the Door

The position of the tool is installed on the inside of the door which is connected to a solenoid that is installed to lock the door leaf. The solenoid is installed embedded in the jamb, is technically stronger and the key known as the iron core tongue locks and opens if the solenoid is On or Of. The camera is connected to the Raspberry Pi via a USB cable and a micro USB to HDMI connector installed from the Raspberry Pi is connected to a PC (Personal Computer) monitor screen to display the output of the program being run. Another alternative for designing and running Raspberry Pi programs apart from a PC or laptop is to use the RealVNC (Virtual Network Computing) application which is connected to the LAN (Local Area Network) internet. Furthermore, after the program is run to detect facial recognition objects that have entry access and can open the door, it is shown in Figure 15 below:



Figure 17. Front view device with Camera

Based on figure 17 above, the installed camera will work and detect objects to take pictures through the camera and then match the facial data that has been processed with test data and train data. The results of the test data and train data are stored in the data base which will show that the object is a known or unknown user (known and unknown). The system for reading user data detected by the camera is processed using the Haar Cascada Classifier algorithm method[10]. This classification method is able to detect quickly and works in real-time, the detected image is responded to, then the system sends it via the internet which is stored in the data base. The next step is to test the tool to open the door via facial recognition. Testing is carried out with several different human objects and is categorized into:

- a. User as a user has a data base
- b. Non-users do not have Base data

The first test experiment was carried out by a user who had a dataBase in front of the camera, then the camera system read the face and took a picture, matched it with the dataBase and displayed on the home

owner's Android cellphone that there was a person. If the user who is in front of the camera and has access rights opens the door, then the information visible on the user's Android reads known.[13],[14]. Meanwhile, if the user or user in front of the door is someone who does not have access rights to open because the photo data is not stored in the data base, then the information that appears is unknown (unknown) so they cannot open the door.

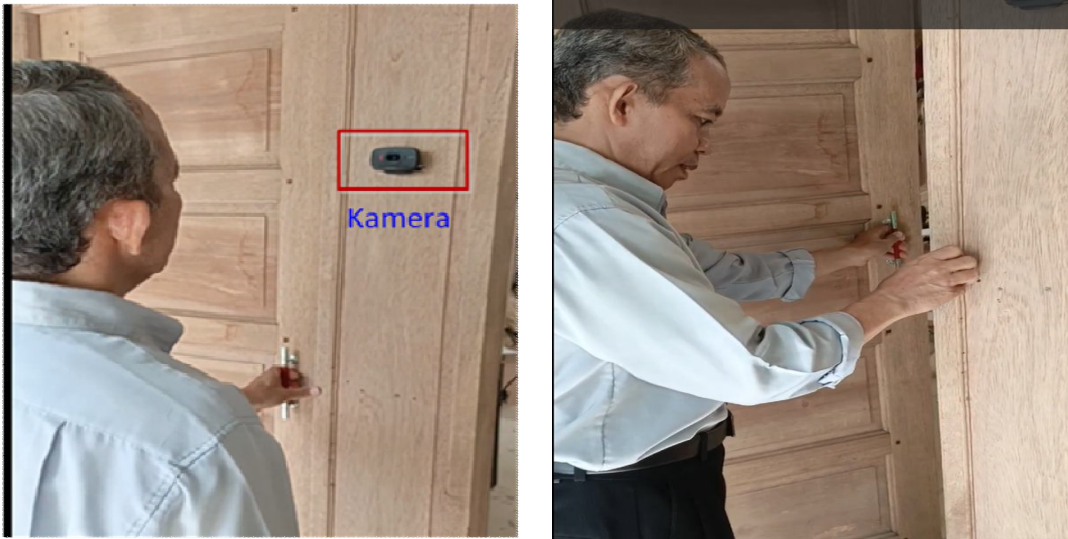

Figure 18. Face recognition testing (user & door open)

The following is a facial recognition program:

```
# Detect the fce boxes
boxes = face_recognition.face_locations(frame)
#compute the facial embeddings for each face bounding box
encodings = face_recognition.face_encodings(frame, boxes)cc
names = []

#loop over the facial embeddings
for encoding in encodings:
    #attempt to match each face in the input image to our known
    #encodings
    matches = face_recognition.compare_faces(data["encodings"],
        encoding)
    name = "Unknown" #if face is not recognized, then print Unknown

    #check to see if we have found a match
    if True in matches:
        #find the index of all matched faces then initialize a
        #dictionary to calculate the total number of times each face
        #was matched
        matchedIdxs = [i for (i, b) in enumerate(matches) if b]
        counts = { }
```

```

# loop over the matched indexes and maintain a count for
# each recognized face
for i in matchedIdxs:
    name = data["names"][i]
    counts[name] = counts.get(name, 0) + 1

    #determine the recognized face with the largest number
    #of votes (note: in the event of an unlikely tie Python
    #will select first entry in the dictionary)
    name = max(counts, key=counts.get)

    #If someone in your dataset is identified, print their name on the screen
    if currentname != name:
        currentname = name
        print(currentname)

```

DISCUSSION

Design tools with technological innovation to run programs using a Single Board Computer (SBC) which is capable of running administrative programs and innovation programs based on intelligent computers. Single Board Computer which is also known as a minicomputer or single board computer which is used as a server computer like a conventional computer. Currently, single board computers are more trendy, called Raspberry Pi, which are used to design tools such as robots, IoT, sensors, remote monitoring and so on. The intelligence of the minicomputer in this research is that it is able to run a program to open doors by recognizing the face of a person's object which is run via a laptop and can be controlled using Android via the network. The connection that connects intelligent Computers or Raspberry Pi as the system control center in the CPU (Central Processing Unit) with other devices is using the RealVNC application. The technique for connecting the Raspberry Pi as a control center with a laptop or Android is to install and then set the IP (Internet Protocol) Network (LAN) Address using BoneMalinoWifi with IP Address 192.168.1.13 by setting a password with the pi code. The next step is so that the Raspberry Pi program can be accessed on a laptop or Android, the IP Address is set to be the same as the IP Address code connected to the laptop and the RealVNC display which has been successfully registered using an email account as in the image below.

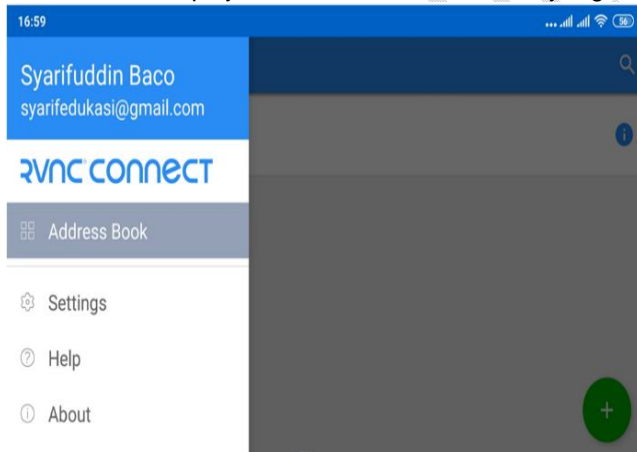

Figure 19. RealVNC connection with Raspberry Pi

After connecting RealVNC with the Raspberry Pi, the process continues, namely Authentication as validation of the account that has been registered for use on each device connected to the Raspberry Pi via the LAN network.

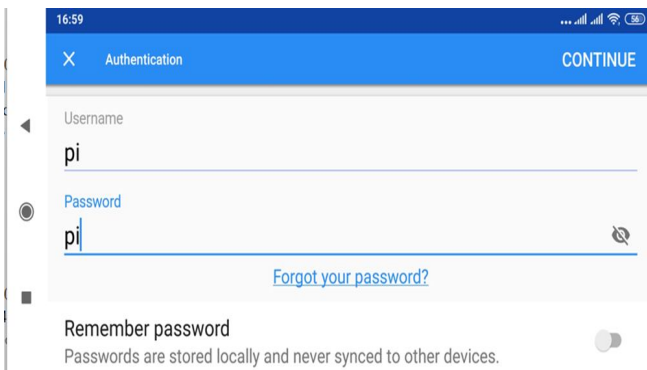

Figure 20. Account and password validation

The design of tools and programs opens the door by detecting faces that are ready to run and if it is not connected to a laptop or Android, the Raspberry Pi can be run directly from the Raspberry Pi using the monitor's visual output connected from a VGA cable using a USB HDMI to VGA connector so that it appears on a projector or monitor like the picture below.

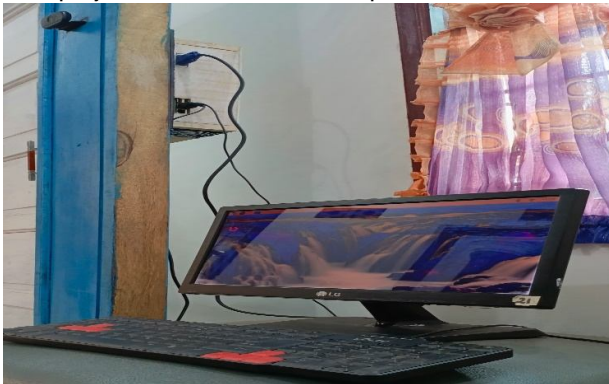

Figure 21. Connecting and running an intelligent computer program

The design of the tool with a complete intelligent computer installed on the inside of the door is connected to several USB ports, namely:

1. The Raspberry Pi port is connected to a USB camera on the front of the door which works to detect objects if there are people reflected with light captured by the camera.
2. PC monitor USB port that displays Raspberry Pi programs when the tool is activated.
3. The USB keyboard port as an input device is used to create program codes in Python which is integrated with the database data system to store image data detected by the camera.
4. The mouse USB port is used to run the designed program.

Meanwhile, programs with the Android system can be controlled and monitored via a network connection as shown in the following image:



Figure 22. Raspberry Pi Android connection

The Raspberry Pi program is run and displayed on Android via the network-connected RealVNC application. You can test opening the entrance door or when you want to leave the house by pressing the push button or what is called push On.

Below is an example of an application display via Android that can be monitored from a distance if an object or person is detected by the camera standing in front of the door.

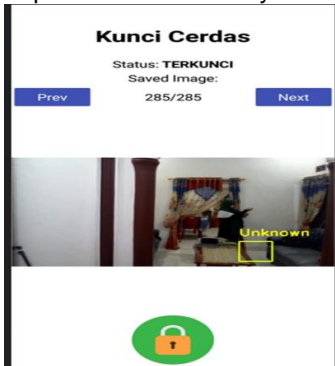

Figure 23. Locked door Android application display

In figure 23 is a display of the application and information provided to home owners who are monitored remotely with an internet connection. The information provided shows that there is an object detected by the camera that is unknown and cannot be accessed by opening the door, then you can see the position is locked with a green button. Meanwhile, in Figure 24 below, it provides information to the owner that an object has been detected and has access rights to open the door and the application shows that the key is open, marked with a red key symbol.

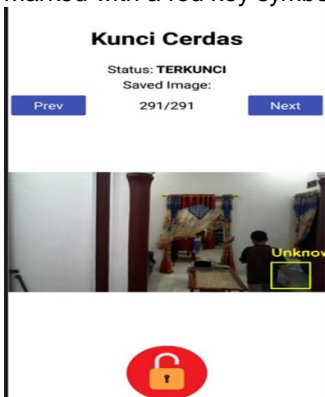
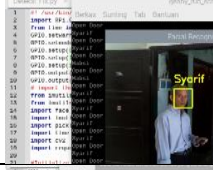



Figure 24. Open door Android application display

The following are the results of testing the face detection tool to open the door, shown in table 1 below.

Table 1. User and non-user testing

| Users | Testing to | | | | | Detection results | System information |
|-------|------------|--------|--------|--------|--------|--------------------------------------|---|
| | 1 | 2 | 3 | 4 | 5 | | |
| 1 | √ | √ | √ | √ | √ | known (known) |  |
| 2 | √ X | √ X | √ X | √ X | √ X | Known unknown (unknown, known) |  |
| 3 | X | X | X | X | X | Known (known) |  |

4

X X X X X Unknown (unknown)



Explanation √= known, known X= unknown, not known

Based on the test data as in table 1 above, it can be explained that the test was carried out on 4 human objects and the test was carried out 5 times each. Users 1, 3 and 4 are users in front of the camera and the system information shows that some users are known and some are unknown. Testing on the second user consists of 2 human objects that are detected by the camera and then information is visible, namely unknown and known, meaning that there is one user who is not known in the system because there is no training data and test data process. Meanwhile, another user is known, meaning known based on training data and testing data stored in the data base.

CONCLUSION

Based on the description in the introduction, methods, research results and discussion, the researcher took the essence as the research conclusion as follows:

1. Intelligent Computers are able to recognize faces according to testing data and test data stored in a database to open the door of the house. The object or person in front of the camera is detected and then does not have access rights to open the door, so the system provides information to the user via Android which is monitored remotely via a network of both family members and other people.
2. An intelligent computer connected to RealVNC via an internet network can be accessed from other devices to run a program for designing a door opening tool with face detection which aims to provide homeowners with security in the event of theft because it can be monitored via Android and the solenoid lock is embedded in the frame so it is not visible to the human senses.
3. Validation and verification of facial detection data is capable of distinguishing and providing system information about known and unknown people and in real time the data is stored in a database in image format in large file sizes so that it can be arranged within >30 days, so that Old data is automatically deleted. Testing is carried out with twin faces capable of detection and validation, those with testing data can open the door and those without testing data cannot open the door.
4. The combination door opening system, in addition to face detection, also has a Push On button installed inside to open the door if guests come or family wants to leave the house using a push system.
5. Face detection testing from a camera range with a distance of 1-310cm is detected and a distance greater than 310cm means the object is not detected by the camera.

Disclaimer (Artificial intelligence)

Option 1:

Author(s) hereby declare that NO generative AI technologies such as Large Language Models (ChatGPT, COPILOT, etc) and text-to-image generators have been used during writing or editing of manuscripts.

Option 2:

Author(s) hereby declare that generative AI technologies such as Large Language Models, etc have been used during writing or editing of manuscripts. This explanation will include the name, version, model, and source of the generative AI technology and as well as all input prompts provided to the generative AI technology

Details of the AI usage are given below:

- 1.
- 2.
- 3.

REFERENCES

- [1] VA Kurniyanti and D. Murdiani, "Comparison of Waterfall Models with Prototypes in Website-Based Information System Development," *J Syntax Fusion*, vol. 2, no. 08, Art. no. 08, Aug. 2022, doi: 10.54543/fusion.v2i08.210.
- [2] HA Saputra, F. Utaminingrum, and W. Kurniawan, "Face Detection and Recognition as Security Support Using the Haar-Classifer and Eigenface Algorithms Based on Raspberry Pi," p. 9.
- [3] ZS Friendly and HR Safitri, "Tensorflow-Keras Based Masked Face Detection for Entry Access Gate Control Using Raspberry Pi4".
- [4] LW Alexander, SR Sentinuwo, and AM Sambul, "Implementation of a Facial Recognition Algorithm to Detect Visual Hacking," vol. 11, no. 1, p. 8, 2017.
- [5] T. Ahmed, AT Bin Nuruddin, AB Latif, SS Arnob, and R. Rahman, "A Real-Time Controlled Closed Loop IoT Based Home Surveillance System for Android using Firebase," in *2020 6th International Conference on Control, Automation and Robotics (ICCAR)*, Singapore: IEEE, Apr. 2020, pp. 601–606. doi: 10.1109/ICCAR49639.2020.9108016.
- [6] S. Holm and S. Ringström, *Comparing Pixel-based Quality of Experience in Remote Desktop Applications*. 2020. Accessed: June. 10, 2024. [Online]. Available: <https://urn.kb.se/resolve?urn=urn:nbn:se:hv:diva-16113>
- [7] A. Jadhav, V. Oswal, S. Madane, H. Zope, and V. Hatmode, "Vnc Architecture Based Remote Desktop Access Through Android Mobile Phones," vol. 1, no. 2.
- [8] Alfira Saputri, "Getting to Know the Raspberry Pi: Definition, History, Benefits and Influence in the IT Industry, Website Creation Services, IOT, ERP - DERIOTA Indonesia Tehnology." Accessed: Jun. 09, 2024. [Online]. Available: <https://deriota.com/news/read/1240/mengenal-raspberry-pi-pengertian-sejarah-manfaat-dan-pengaruh-dalam-industri-IT.html>
- [9] Alfira Saputri, "Getting to Know Raspi as a Mini Computer Device," Getting to Know Raspi as a Mini Computer Device. Accessed: Jun. 08, 2024. [Online]. Available: <https://bisa.design>
- [10] Abhishek Dutta and Jaydip Sen, "Object Detection and Facial Features Identification in Python using OpenCV," 2020, doi: 10.13140/RG.2.2.32113.92005.
- [11] Youming Lin and M. Di Francesco, "Energy consumption of remote desktop access on mobile devices: An experimental study," in *2012 IEEE 1st International Conference on Cloud Networking (CLOUDNET)*, Paris, France: IEEE, Nov. 2012, pp. 105–110. doi: 10.1109/CloudNet.2012.6483663.
- [12] MIH -, "Software Development Life Cycle (SDLC) Methodologies for Information Systems Project Management," *Int. J. Multidiscip. Res.*, vol. 5, no. 5, p. 6223, Sept. 2023, doi: 10.36948/ijfmr.2023.v05i05.6223.
- [13] R. Muwardi and RR Adisaputro, "Design of a Door Security System Using Face Detection," *J. Technol. Electro*, vol. 12, no. 3, p. 120, Oct. 2021, doi: 10.22441/jte.2021.v12i3.004.
- [14] R. Yustiawati et al., "Analyzing Of Different Features Using Haar Cascade Classifier," in *2018 International Conference on Electrical Engineering and Computer Science (ICECOS)*, Pangkal Pinang: IEEE, Oct. 2018, pp. 129–134. doi: 10.1109/ICECOS.2018.8605266.
15. Venkata NY, Rupa C, Dharmika B, Nithin TG, Vineela N. Intelligent secure smart locking system using face biometrics. In *2021 International Conference on Recent Trends on Electronics, Information, Communication & Technology (RTEICT) 2021 Aug 27 (pp. 268-273)*. IEEE.
16. Challa KE, Boddupally KA, Lakha MA. An Intelligent Automate Door Access Control and Home Security System Based on Face Recognition. *International Journal of Scientific Engineering and Technology Research*. 2017 Feb;6(05):0829-33.
17. Gates KA. *Our biometric future: Facial recognition technology and the culture of surveillance*. NYU Press; 2011 Jan 23.
18. Adjabi I, Ouahabi A, Benzaoui A, Taleb-Ahmed A. Past, present, and future of face recognition: A review. *Electronics*. 2020 Jul 23;9(8):1188.
19. Kortli Y, Jridi M, Al Falou A, Atri M. Face recognition systems: A survey. *Sensors*. 2020 Jan 7;20(2):342.
20. Norman D. *Turn signals are the facial expressions of automobiles*. Diversion Books; 2014 Dec 2.