

# Design of the system of an assemblable channel slope weeder

## ABSTRACT:

If the roots of the water channel slope dig into the soil, it may cause the soil structure to loosen, and then increase the risk of slope landslide[1]. In this context, the design of a channel slope weeder that can adapt to different slopes is very important for the protection of the water channel slope. The weeder concept vehicle designed in this paper is mainly composed of four parts: drive car, frame mechanism, track mechanism and weeder mechanism. At the same time, the structure is analyzed by finite element method, and the stability and safety are analyzed by strength. The reference is provided for the design of the algal removal vehicle on the channel slope.

*Key words: channel slope, weeding, finite element analysis*

## 1.INTRODUCTION

Weeding of water conveyance channel slope is an important project management measure, which involves many technical and environmental considerations[2]. Especially in slope engineering, the stability of soil is very important to the long-term operation of engineering structures[3]. By weeding regularly, the soil structure can be effectively prevented from being disturbed by the roots, and the stability of the slope and the overall project safety can be maintained. Secondly, slope weeding also helps to reduce soil erosion. In large-scale water conservancy projects such as long-distance channel water delivery, soil and water loss of slope will not only cause waste of soil resources, but also lead to water pollution and ecological environment problems. Through effective weeding measures, soil surface erosion can be reduced during rainfall, surface water quality can be protected, ecological balance can be maintained, and environmental protection concept of sustainable development can be met[4]. In addition, slope weeding is also an important means to improve the beauty of the project and management efficiency[5,15-18]. Long-term vegetation growth will not only affect the visual

effect of the engineering facility, but also may lead to maintenance management difficulties and increased costs. By regularly removing weeds, you can not only beautify the engineering environment, but also enhance the efficiency of project management and the overall image of sustainable development[6,11-14].

## 2. OVERALL STRUCTURE DESIGN OF CHANNEL SLOPE WEEDER SYSTEM

Channel slope weeder is divided into the following four mechanisms:

- 1) Drive the car: the two front wheels are responsible for steering, the two rear wheels are responsible for providing driving power, the overall length, width and height size is not less than: 2000mm\*700mm\*700mm;
- 2) Frame structure: frame structure a single frame length of 4000mm, width of 2000mm, two groups of assembly can reach 8000mm;
- 3) The track mechanism: through multiple groups of track wheels drive the frame structure to move laterally, the overall length, width and height of the track mechanism is not less than 2000mm\*300mm\*440mm, and the working slope is not less than 45°;
- 4) Weeding mechanism: the weeding mechanism is controlled by the motor, which can realize the adjustable height up and down, the adjustment height range is not less than 200mm, and the mowing diameter range of a single group of mechanisms is not less than 700mm.

The four institutions are constructed with 40 square steel frames to ensure sufficient strength. The following are the four parts of the drive car, frame mechanism, track mechanism and weeding mechanism to introduce its design, and the strength of the frame structure to meet the safety requirements [19,20].

### 2.1 COMPOSITION PRINCIPLE

As shown in Figure 1 in the working state of the slope weeding vehicle of the South-to-North Water Transfer channel, the weeding vehicle is mainly composed of four parts: drive car, frame mechanism, track mechanism and weeding mechanism. The drive car moves forward on the trunk road to provide power for the entire weeder. The frame mechanism is mainly composed of 40 square steel splicing, easy to install and disassemble, and the frame mechanism and track mechanism are installed together, driving the frame to move horizontally along the ramp to complete the weeding operation. The main body of the weeding mechanism is mainly composed of two parts: the motor and the nylon rope. The motor drives the nylon rope to rotate and cut the weeds, and the height can be adjusted according to different conditions to adapt to different slopes.

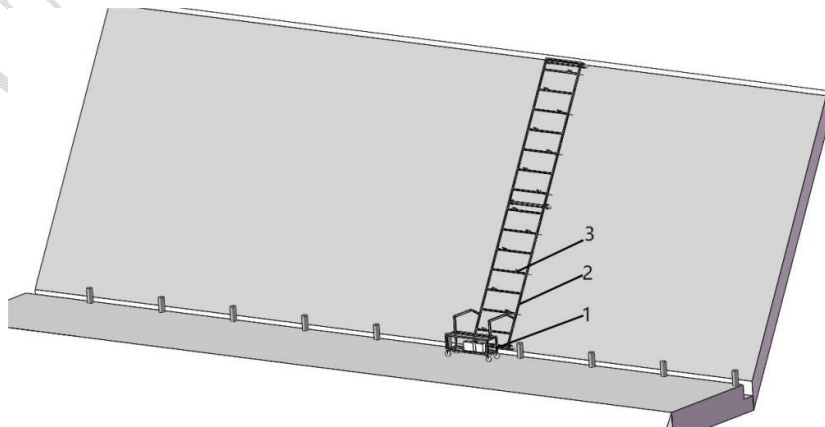

(a) Effect diagram of the working state of the weeder

1. drive car structure 2. frame structure 3. weeding mechanism

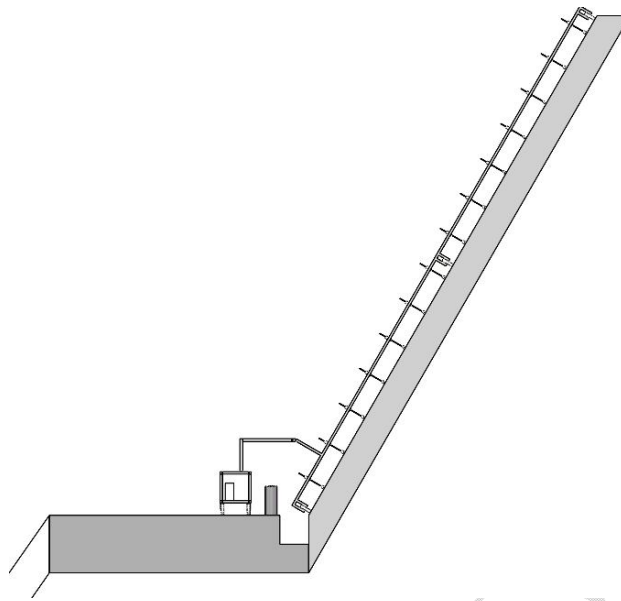

(b) Side view of the working status of the mower

Figure 1. Overall picture of the weeder on the slope of the South-to-North Water Transfer channel

## 2.2 STRUCTURE DESIGN OF DRIVE CAR

The driving car is mainly composed of mechanical arm, car frame, small distribution box, light gasoline generator, wheels and other devices. The overall frame is composed of 40 square steel, the overall length, width and height are not less than: 2000mm\*700mm\*700mm, and the interior has enough space to install gasoline generators and distribution boxes and other supporting devices. The two front wheels of the driving car are responsible for steering, and the two rear wheels are responsible for driving. Two 40-square steel mechanical arms are installed on the upper part of the driving car model, as shown in Figure 2.

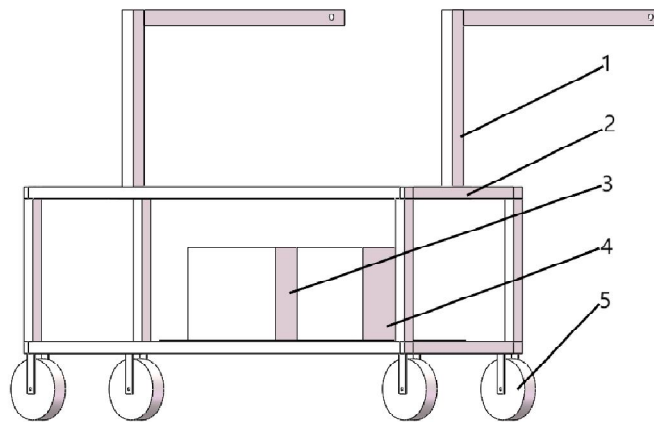
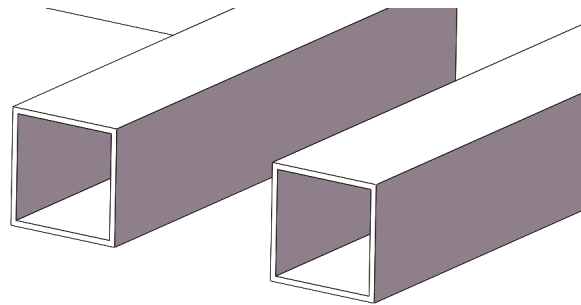

Figure 2. Structure design of the drive car

1.mechanical arm 2.car frame 3.distribution box 4.gasoline generator 5.wheels

The overall frame of the drive car is composed of 40 square steel, the thickness of which is 2mm. The model is shown in Figure 3. The mechanical arm on the upper part of the drive car and the frame structure are connected by pins, the Angle can be adjusted with the slope, and the three tracks and weeding mechanism are connected by lines inside the mechanical arm to provide continuous forward power. The distribution box controls the overall operation and the operation of the individual mechanism respectively, which is convenient to adapt to the different working states of the weeder. Considering the outdoor operation, the power needs to be convenient and efficient, the light gasoline generator is selected as the source of all the power of the whole weeder, and the 10KW open-rack gasoline generator is selected, as shown in Figure 4.



**Figure 3. Design of 40 square steel structure**



**Figure 4. 10KW open frame gasoline generator**

### **2.3 FRAME STRUCTURE DESIGN**

The frame structure is composed of three parts: transverse longitudinal beam, mounting plate and weeding mechanism installed on the frame structure[7]. The length of a single frame group is 4000mm, as shown in Figure 5, the width is 2000mm, and the two groups can reach 8000mm after assembly. Each frame mechanism and track mechanism are assembled by mounting plate, the size of which is 120\*120\*4mm. Bolts and nuts are used to fix the installation plate, as shown in Figure 6. The frame structure can span the entire slope, and only one way movement can achieve the weeding function. The main body of the frame is made of 40 square steel splicing, each beam is equipped with weeding mechanism, and staggered installation increases the weeding area. The frame mechanism and the track mechanism are installed in phase, which can adapt to different slopes and ensure that the frame structure will not slip.

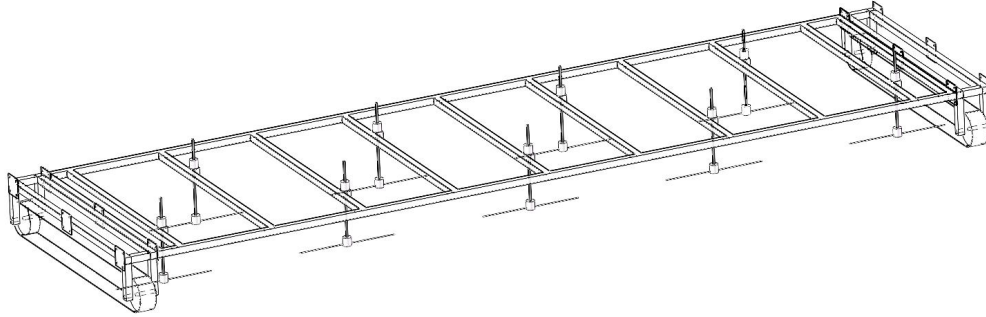

**Figure 5. Assembly diagram of 4000mm frame structure**

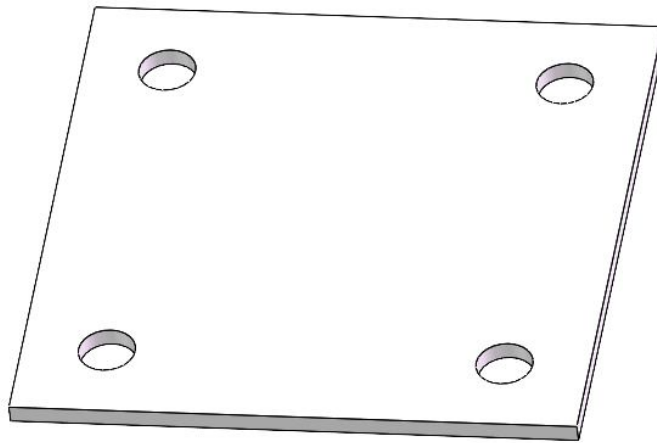

**Figure 6. Mounting plate**

#### **2.4 TRACK MECHANISM DESIGN**

The main body of the track mechanism is composed of three parts: fixed frame, track wheel and mounting plate. The frame structure is driven by multiple groups of track wheels for lateral movement. The overall length, width and height of the track mechanism are not less than 2000mm\*300mm\*440mm, as shown in Figure 7, and the working slope is not less than 45°. The main body of the fixed frame is welded by 40 square steel, and the side welded mounting plate can be assembled with the frame mechanism to adapt to the width of the channel slope.

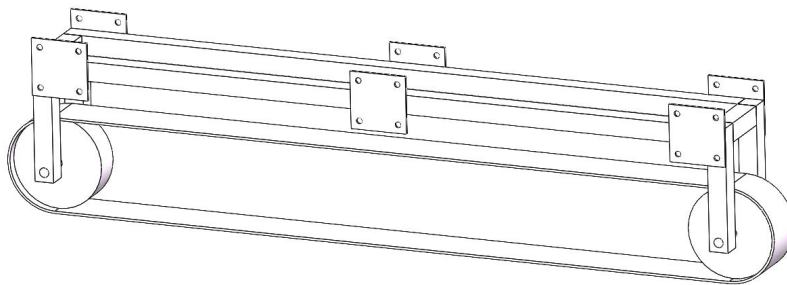

**Figure 7. Track mechanism diagram**

## 2.5 DESIGN OF WEEDING MECHANISM

The main body of the weeding mechanism is composed of two parts: motor and nylon rope. The height of the weeding mechanism is controlled by the top motor, which can realize the adjustable height up and down, and the adjustment range is not less than 100mm. The lower motor drives two nylon ropes to rotate at high speed to achieve weed removal. The diameter of the mowing range of a single group is not less than 700mm. The nylon rope is rotated by the motor to cut weeds, and the working height can be adjusted up and down through the motor on different slopes to meet the weeding work under various working conditions. The weeding mechanism model is shown in Figure 8. The overall cutting height of the weeding mechanism can be adjusted from 5-205mm, and the minimum cutting height of weeds is 5mm, as shown in Figure 9.

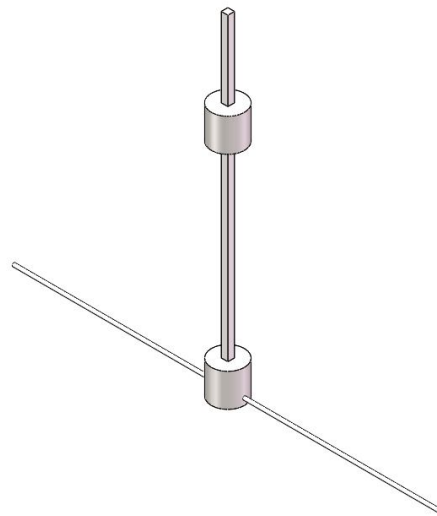
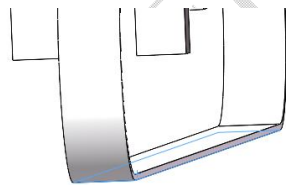

Figure 8. Model of weeding mechanism



垂直距离: 5mm

Figure 9. Height diagram of weeding mechanism

## 2.6 CONTROL SYSTEM

The designed control system includes the lifting system of the weeding mechanism, the motor of the weeding mechanism driving the nylon rope, the internal motor of the track, the driving motor of the car, etc. There are two motors in each weeding mechanism, one realizes the lifting of the weeding mechanism as a whole, and the other drives the rotation of the nylon rope through the motor to achieve the pruning of weeds; The motor in the driving car and track

controls the traveling speed, realizing the same speed of multiple wheels and realizing multi-wheel deviation correction.

In this design, STM32 chip is the main control chip, and the motor control system is designed and developed independently, which can meet the lift and fall of 7-14 sets of weeding mechanism at the same time, and the rotation speed is synchronized with the rotation direction. At the same time, through programming, the action of the drive motor can be coordinated/separately controlled to ensure that the drive car and the frame structure move forward and backward simultaneously.

### 3. STABILITY AND STRENGTH ANALYSIS OF FRAME STRUCTURE

Because the length of the channel slope is mostly 4000-8000mm, when the two sets of 4000mm frames are assembled together, the load and working conditions are the most severe, so the stability analysis and strength check of the assembled frames are carried out at this time[8-9].

#### 3.1 STABILITY ANALYSIS

Strength check is carried out on the two sets of 4000mm frames. After the assembly of the two sets of frame mechanisms, the total mass is expected to be about 120kg, the height of the center of gravity is about 313mm, as shown in Figure 10, and the anti-roll moment is  $1200N \times 0.313\text{ m}$ . When the external thrust is greater than 2009N at the height of 0.5 m, the center of gravity is in the middle. It will overturn and has excellent stability.

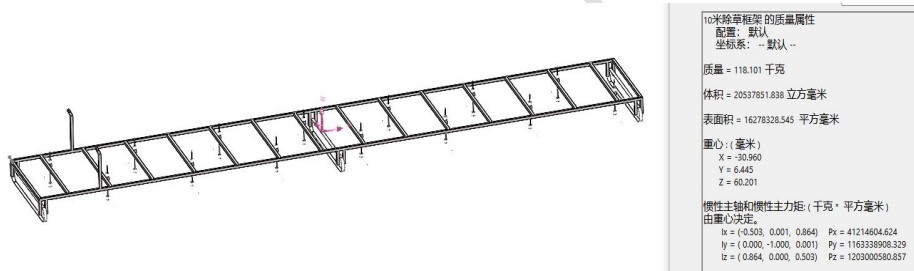

Figure 10. Center of gravity and mass of the overall frame

#### 3.2 STRENGTH OF FRAME STRUCTURE

ANSYS workbench was used to test the strength of the frame structure model[10]. Contact constraints were applied to the bottom of the frame. In order to verify the load-bearing capacity of the frame, 500N force was applied to the top of the beam frame, and 500N force in the horizontal direction was applied to the connection with the manipulator arm of the drive car to analyze the overall strength of the frame.

Firstly, the model was meshed. The meshing method was set to hexahedral mesh, and the mesh size was set to 10mm, as shown in Figure 11.

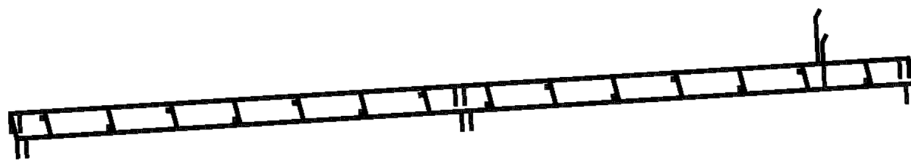
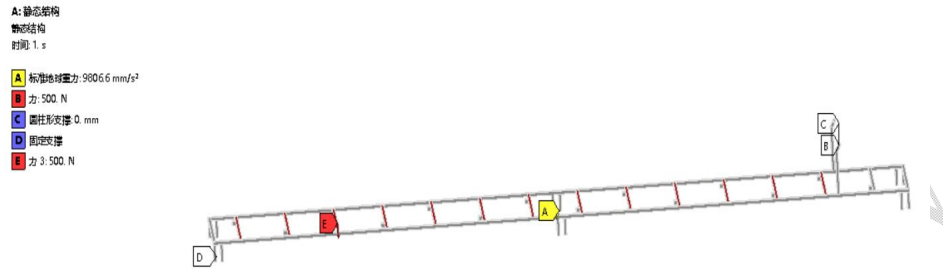

Figure 11 Grid division

The number of grid nodes is 371104 and the number of grid units is 186438.

Because the bottom of the frame is connected to the track wheel, the contact constraint is adopted and the standard acceleration of gravity is added. In order to verify that the structure has sufficient strength, 500N force is applied to the top of the beam frame, the direction is perpendicular to the beam frame downward, and the constraint and 500N load are applied to the connection of the mechanical arm of the drive car. Constraints and load application are shown in Figure 12.



**Figure 12. Adding constraints and loads**

According to the above Settings, the deformation and overall stress of the frame structure are analyzed. The stress-deformation cloud diagram is shown in Figure 13.

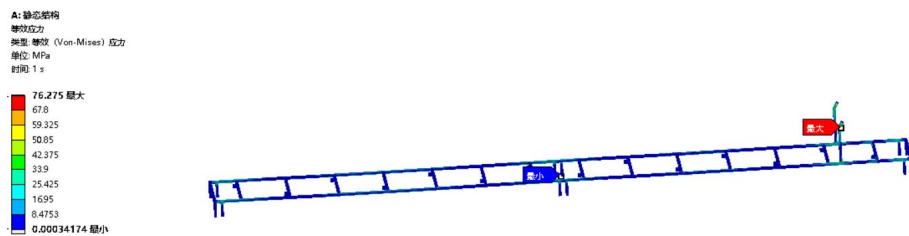

**(a) Stress nephogram**



**(b) Deformation cloud image**

**Figure 13. Intensity cloud image of vertical pole**

According to the stress and deformation cloud map, the maximum deformation of the frame structure is 7.02mm and the maximum stress is 76.275MPa, which shows that the strength meets the requirements and there is a large margin.

#### 4 CONCLUSIONS

Slope weeding in long-distance channel water transfer project is not only a simple greening management, but also a comprehensive engineering measure involving project safety, environmental protection and social benefits. Through scientific and reasonable weeding program, it can effectively prevent risks, protect the ecological environment, ensure the long-term stable operation of the project, and provide solid and reliable technical support and guarantee for the allocation of water resources.

The design of the channel slope weeder as the research object, completed the analysis of the design scheme, the establishment of the model, the simulation analysis under harsh conditions, and the stability analysis. The results show that the stability is excellent, the maximum deformation of the frame structure is 7.02mm and the maximum stress is 76.275MPa under bad working conditions, which shows that the strength meets the requirements and has a large margin. The design and simulation optimization results can provide reference for the overall scheme design of the channel slope weeder and improve its safety and economy.

## REFERENCES

1. Song Jun h. Car to remove algae in water main canal slope design and research [D]. University of north China water conservancy and hydropower, 2023. The DOI: 10.27144 / , dc nki. GHBS. 2022.000611.
2. Li Bing, ZHANG Jixiang, Duan Junfa. Design of electric track vehicle for removing algae from slope of South-to-North Water Transfer channel [J]. Modern Agricultural Machinery,2023(03):122-124.
3. Li Cheng, HU Quanyi, Duan Chunjian. Design of underwater cavitation jet cleaning device for multi-functional special vehicle for removing algae from the slope of the middle line of the South-to-North Water Transfer [C]// Chinese Hydraulic Society. The fifth part of the Proceedings of the 2019 Academic Annual Meeting of the Chinese Hydraulic Society. Yellow River Machinery Factory; Yellow River Conservancy Commission; School of Mechanical Engineering; North China University of Water Resources and Electric Power; Henan Branch of Construction Administration of Middle Route of South-to-North Water Diversion Project; , 2019:5. DOI: 10.26914 / Arthur c. nkihy. 2019.097493.
4. The scene heroes. Electric crawler slope to the work device of the car to remove algae research [D]. North China university of water conservancy and hydropower, 2023. The DOI: 10.27144 / , dc nki. GHBS. 2023.000805.
5. Zhang Jianwei, Ma Hongdong, Song Gangfu, et al. Study on slope soil characteristics and ecological slope protection benefits in the South Section of the Middle Route of South-to-North Water Transfer Project [J]. Soil and Water Conservation in China,2024,(04):61-66.
6. Chang Zhibing, Huang Bin, SHI Zhaoying, et al. Comprehensive governance of the slope stability of south-to-north water transfer project research [J].transportation research, 2021, (21) : 5-6. DOI: 10.14125 / j.carol carroll nki zjsy. 2021.21.002.
7. Fu Haiyong, Liang Jianlin, HU Qinggen. Mechanical design of prefabricated Beret frame building frame based on SolidWorks [J]. Equipment Manufacturing Technology,2021,(10):112-114+119.
8. Jiang Zhanchao, Ding Huaiping, Gao Cheng, et al. Structural Optimization and Finite Element Analysis of High-altitude Lifting Frame [J]. Machine Tool & Hydraulics,2024,52(12):143-149.
9. Zhang He, Wang Jianying, Yin Enhua. Finite Element Analysis of Frame Structures under Applied Loads [J]. Mechanical Engineering and Automation,2024,(01):92-94.

10. Zhang Kunyong, LI Guangshan, Li Wanglin, et al. Finite element stability analysis of slope in South Main Channel of South-to-North Water Diversion [J]. *Journal of Hebei University of Technology (Natural Science Edition)*,2016,33(04):27-32.
11. Ree WO, Palmer VJ. *Flow of water in channels protected by vegetative linings*. US Department of Agriculture; 1949.
12. Kulkarni AA, Nagarajan R. Drone survey facilitated weeds assessment and impact on hydraulic efficiency of canals. *ISH Journal of Hydraulic Engineering*. 2021 Apr 3;27(2):117-22.
13. Knight DW, Hazlewood C, Lamb R, Samuels PG, Shiono K. *Practical channel hydraulics: Roughness, conveyance and afflux*. CRC Press; 2018 Mar 5.
14. Hai L, Lv Y, Tan S, Feng L. Study on the influences of the fractal dimension of the root system and slope degree on the slope stability. *Scientific Reports*. 2023 Jun 24;13(1):10282.
15. Shen Y, Li Q, Pei X, Wei R, Yang B, Lei N, Zhang X, Yin D, Wang S, Tao Q. Ecological restoration of engineering slopes in China—A review. *Sustainability*. 2023 Mar 17;15(6):5354.
16. Singh P, Bardhan A, Han F, Samui P, Zhang W. A critical review of conventional and soft computing methods for slope stability analysis. *Modeling Earth Systems and Environment*. 2023 Mar;9(1):1-7.
17. Lann T, Bao H, Lan H, Zheng H, Yan C. Hydro-mechanical effects of vegetation on slope stability: A review. *Science of the Total Environment*. 2024 Mar 12:171691.
18. Wang L, Wu C, Yang Z, Wang L. Deep learning methods for time-dependent reliability analysis of reservoir slopes in spatially variable soils. *Computers and Geotechnics*. 2023 Jul 1;159:105413.
19. Yavna V, Shapovalov V, Okost M, Morozov A, Ermolov Y, Kochur A. Modeling of long-term train loads impacts on subgrade soils: a review. *International Journal of Transportation Science and Technology*. 2023 Sep 1;12(3):729-52.
20. de Oliveira EM, Hermógenes GM, da Costa Brito L, Silva BM, Avanzi JC, Beniaich A, Silva ML. Cover crop management systems improves soil quality and mitigate water erosion in tropical olive orchards. *Scientia Horticulturae*. 2024 Apr 15;330:113092.