

# THE EFFECTS OF A THREE-ARM HAMMER CRACKER/ BEATER ON THE PERFORMANCE OF A NEWLY DEVELOPED PALM KERNEL SHELL CRACKING MACHINE

## ABSTRACT

The effects of a 3-arm hammer cracker/ beater on the performance of a newly developed palm kernel shell cracking machine have been determined. The newly developed palm kernel cracker was equipped with a 3-arm hammer beater shaft, and a constant weight of 3000g of palm kernel shells were cracked under various operating speeds ranging from 800- 1600 rpm. During this period the performance of the newly developed machine equipped with the 3-arm hammer beater was evaluated. It was discovered that the 3000g of palm kernel nuts were cracked in just 30.14 seconds at a speed of 1600 rpm. The number of whole nuts was 541 at the operating speed of 1000 rpm which was the highest of all the processing speeds used. It was also discovered that the number of uncracked nuts decreased with increasing operating speed. Unbroken nuts were 87 at 1000 rpm and were the lowest operational speeds used. For the number of cracked nuts it was discovered that the number of cracked nuts increased with an increase in cracking speed or operational speed. The work observed that the effective capacity of the machine equipped with the 3-arm hammer beater increased with an increase in operational speed. The cracking efficiency also increased with increasing operational speed. Un-cracked nuts loss was seen to decrease as the operational speed increased. The highest performance efficiency of 84.53, the highest overall efficiency of 82.95, and the smallest value of split nut loss of 13.59 all occurred at the operational speed of 1000 rpm. It is therefore recommended that for this newly developed palm kernel shell cracking machine equipped with a 3-arm hammer beater the best operating speed should be 1000 rpm, to minimize losses and enjoy high performance efficiency.

**Keywords:** 3-arm hammer beater; newly developed; cracking efficiency; cracking time; performance efficiency; overall efficiency.

## 1.0 INTRODUCTION

Palm kernel nut is the basic raw material used in the production of palm kernel oil and palm kernel cake. Cracking palm nuts to release the kernel is an important issue within the palm kernel oil industry. There are basically two methods of this processing: the manual method and the mechanised method. The manual method of palm kernel nut cracking also known as the traditional method of palm kernel nut cracking makes use of stones to crack the nuts and kernels are separated by hand-picking from the shell simultaneously. This method is time-consuming and labour-intensive. The method cannot meet the demand of the growing international and domestic market. (Ndegwe 1987; Babatunde and Okoli, 1988; Babatunde *et al.*, 1988; FAO 2002; FAO 2004; Asoiro and Udo, 2013; Okoli 2022) The method employs the principle of impact force to crack the nuts to bring out kernel. This is usually done by placing about 4-6 nuts on a flat stone and using another stone as hammer to crack them. The output sometimes may be up to 50kg of kernel in a working day per worker, hence it is usually done by women and children. The mechanised palm kernel nut cracking also known as the modern method palm kernel nut cracking is often of centrifugal type. In this method nuts are fed into a cracking

chamber where they are impacted upon by metal beaters turning at high speeds thereby throwing the nuts against a cracking ring (Offiong, 2024). The nuts impinge the wall at random orientation but with repeated impact due to bouncing until they are discharged, cracked or un-cracked albeit with much kernel breakage as observed by Ibiyeye *et al.*, (2022). Therefore there is a need to investigate the effects of the different types of beaters on the performance of the machine. Usually, mechanised palm kernel nut crackers are designed with adjustments in speed for acceptable cracking efficiency. According to Ibiyeye *et al.*, (2022) knowledge of the force required for nut cracking to achieve minimum impact is important for the improvement of the existing mechanised palm kernel nutcrackers. They maintained that certain factors affect the cracking efficiency of the nut crackers. These factors are: (i) the size of nut (ii) the moisture content of nuts (iii) the crackers rotor speed and (iv) feed rates. A number of researchers have worked on the relationship of these factors to cracking efficiency. Alade *et al.*, (2020) developed a modified palm kernel nut cracker from the conventional palm kernel nut cracker available in the Nigerian market. Performance analysis of the cracker using Minitab17 shows that the efficiency of the machine was influenced by nut sizes and variations in the selected feed rates. The result indicated that the modified palm kernel nut cracker is suitable for processing palm nuts of all sizes when operated at moderate feed rates. It is important to note that the efficiency, capacity and output/hour of the palm kernel nut cracking machine depends on several factors, but in this work emphasis is on shaft speed and the type of cracker hammer/beater used. These two factors influence the quality of cracked palm kernel nuts and will be of great significance to palm kernel nut cracking machine producers, since it will help them decide on the optimum number of arms a hammer cracker/ beater should have for the quality cracking of palm kernel nuts (Antia *et al.*, 2014; Andoh *et al.*, 2015; Apehet *et al.*, 2015; Offiong, 2024).

There are three common varieties of palm kernel nuts. Dura, Pisifera and Tenera. The Tenera is a hybrid of the Dura and the Pisifera. The Dura palm have kernels with a thick shell, the Pisifera palms have kernels with no shell, while the Tenera palm have kernels with a thin shell (Anyane, 1966). In Nigeria it is the Tenera species that is commercially planted hence this research will design and develop a cracker for the Tenera species which is usually between 7-15 mm in length with shell thickness of 1.2mm. The palm tree is one of the greatest economic assets a nation possess. The oils produced from oil palm namely palm oil and kernel oil are used for oil paints, margarine, candle, polish, soap making, glycerin and medical purposes. Oil palm are also used to produce biodiesel. The palm kernel shells are used as a source of energy by blacksmiths and other industries. They palm kernel shells are also used for making brake pads. Also the palm kernel cakes are used in making livestock feeds which are very rich in the essential nutrients required by livestock. For details on the uses of oil palm tree products see (Mba *et al.*, 2015; Mosarof *et al.*, 2015; Asadullah *et al.*, 2014; Adebayo 2004, Emeka and Julius 2007, and Norazura 2017). According to (Badmus, 1991) Nigeria's oil palm exists in small oil palm plantation and wild grove, even though recently some large-scale plantations have been developed. The need of oil palm processing machines suitable for small-scale mills cannot be overemphasised. Machine involved in the palm oil mill process are: palm fruit sterilizer, palm fruit thresher, palm fruit digester, palm oil press machine, palm kernel cracker, palm kernel separator machine and palm kernel oil expeller machine. The design and development of these machines for large scale production has been the subject of many research work. This has resulted in the manufacture of sophisticated and complicated foreign made palm oil processing machines which are not suitable for our small scale production System (Badmus 1991).

The objective of this project is to investigate the effects of a three-arm hammer cracker/ beater in a newly developed palm kernel nut shell cracking machine on the performance and quality of palm kernel nuts cracked and output when shaft speed is varied.

## 2.0 MATERIALS AND METHOD

### 2.1 Materials

The materials and equipment used for this work include the newly designed and produced palm kernel cracking machine, three-arm beater head, timer, dried palm kernel nuts, collecting pans, sorters, tachometer for measurement of speed, and Microsoft Excel 210 of window 7 software. The newly developed machine and the three arm beater head can be seen in Figures 1-3.

#### Description of the functional Components of the Newly Developed Cracker

The functional components of the newly developed cracker machine are: Hopper, Cracking Chamber, Power Transmission Shaft, bearing and bearing housing, pulley, and cracking mechanism.

- A. **Hopper:** The hopper is connected to the conveying channel that leads to the cracking chamber. It is constructed as a truncated square base pyramid with mild steel sheet metal of 1.4mm gauge.
- B. **Cracking Chamber:** The cracking chamber is cylindrical in shape with diameter 370 mm. It is made of a mild steel plate of 3mm thickness. The front and the rear ends of the chamber are covered with circular plates of the same material, thickness and diameter. The internal walls of the cylinder are lined with 12mm iron rods to form the cracking ring.
- C. **Power Transmission Shaft:** The power transmission shaft is made of a 25mm diameter by 1200mm length rod of tool steel with three, beaters welded to one end and a pulley pinned down the other end with a pillow bearing.
- D. **Bearing and Bearing Housing:** Two UC 206, 30mm diameter pillow block bearing are used. The bearing housing is used to hold the bearing firmly to the frame, while the bearing itself holds the shaft in position to minimize friction during rotation.
- E. **Pulley:** Two pulleys of different diameters are used in the design. The pulley is the device that transmits power from prime mover to the cracking mechanism shaft, via two v-belts. The smaller pulley connected to the prime mover is 50mm in diameter while the larger pulley connected to the shaft of the cracking machine is 80mm in diameter.
- F. **Cracking Mechanism:** The three (3) arm hammers crack the kernel nut by beating it against the wall of the cracking chamber. The walls of the cracking chambers are lined with 12mm iron rods to form the cracking ring. The hammers are placed at the angle  $180^{\circ}$ , or  $90^{\circ}$  or  $120^{\circ}$  to each other around the shaft. The rotation of the shaft enables the hammers to hit the kernel laterally and let out the seed from the palm nut in a neat form (Offiong, 2024). See Figure 3 for the complete views of the 3- arm beater head/ shaft.

#### Operating Principles of the Newly Developed Palm Kernel Cracker

The Palm Kernel nuts are fed into the cracking chamber through the hopper, and the hopper's slanting nature facilitates the smooth movement of the kernels as feeding continues. Power is transmitted to the rotor from the prime mover through the v-belt. As the nut are fed from the hopper at moderate speed through the centralized hole in the flywheel, the centrifugal rotating 3-arms hammer beats the palm kernel against the cracking chamber giving rise to a very great impact force that eventually crack the palm nuts. The cracked kernels and shells thereafter passed into the lower circumference of the cracking chamber and are collected for separation. Figure 1 shows the newly produced palm kernel nut cracking machine and Figure 2 shows the exploded view of the newly developed machine.

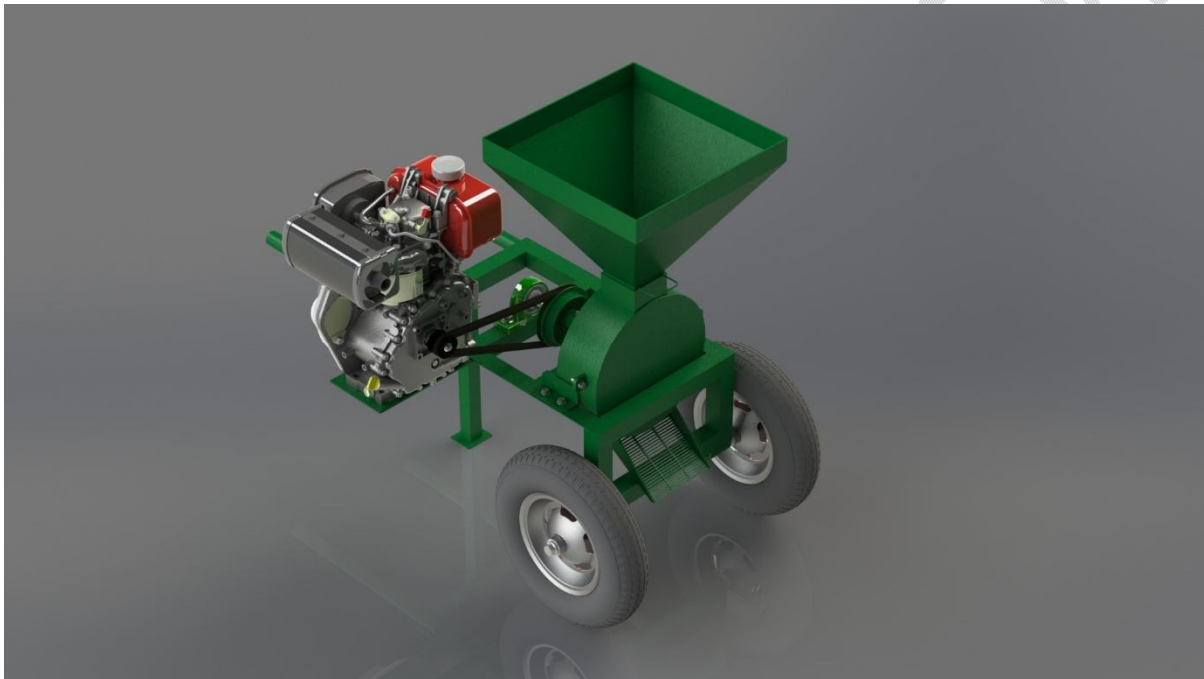

**Figure 1:** Three dimensional model of the developed palm kernel nut cracking machine

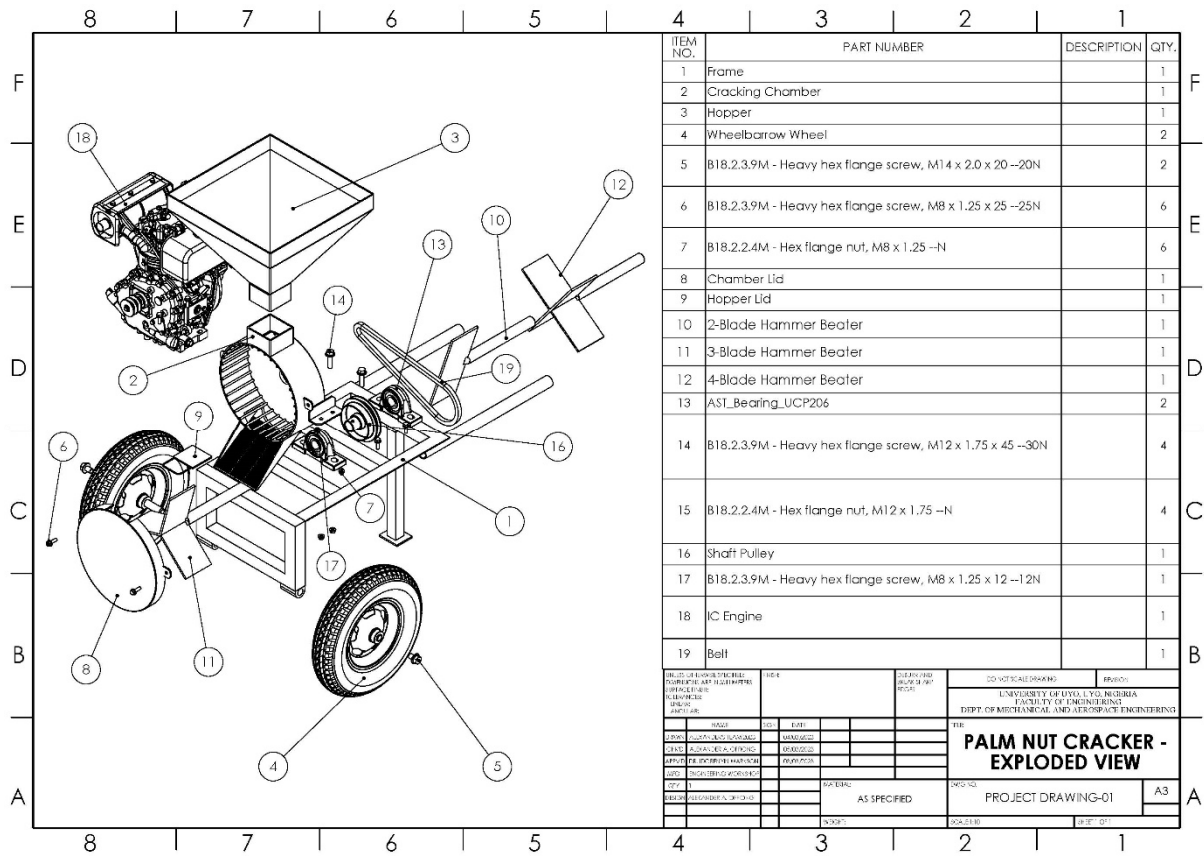

**Figure 2:** Exploded view of model components of the developed palm kernel nut cracking machine

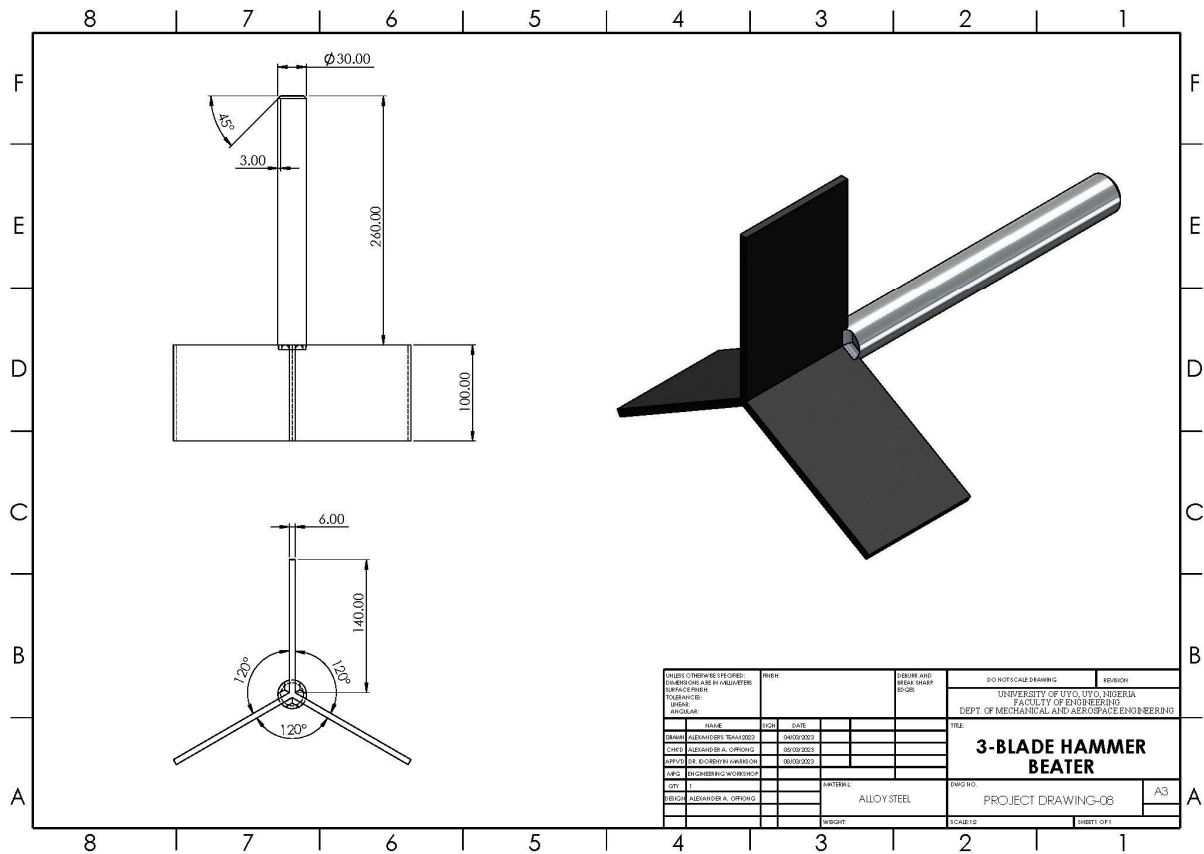

**Figure 3:** Component drawing of the palm kernel nut cracking machine showing the three blade hammer shaft

## 2.2 Method

### Determination of evaluation parameters

Evaluation parameters for the developed crackers include Effective capacity (EC), cracking efficiency (CE), performance efficiency (PE), split-nut loss (%), (SL), (UL), un-cracked nut loss (%); and overall efficiency (OE). These parameters can be calculated using equation (15-20) respectively.

$$EC = M/T \quad - \quad - \quad - \quad (15)$$

$$CE = [N_{cr}/N_{to}].100 \quad - \quad - \quad - \quad (16)$$

$$PE = [N_{wh}/N_{to}].100 \quad - \quad - \quad - \quad (17)$$

$$SL = [N_{br}/N_{to}].100 \quad - \quad - \quad - \quad (18)$$

$$UL = [N_{uc}/N_{to}].100 \quad - \quad - \quad - \quad (19)$$

$$OE = CE \times PE \quad - \quad - \quad - \quad (20)$$

$$N_{br} = N_{to} - (N_{wh} + N_{uc}) \quad - \quad - \quad (21)$$

$$N_{cr} = N_{wh} + N_{br} \quad - \quad - \quad - \quad (22)$$

Where M is total mass of palm nuts fed into the hopper (kg); T is total time taken by the cracked mixture to leave the chute (h) [Cornish, 1991];  $N_{to}$  is the total number of kernel nuts fed into the hopper;  $N_{cr}$  is the total number of cracked kernel [damaged and undamaged] after cracking;  $N_{wh}$  is the number of whole [un-broken] kernel nut after cracking;  $N_{br}$  is the number of broken kernel nuts after cracking; and  $N_{uc}$  is the total number of un-cracked kernel nuts after cracking. In the experiment a constant volume of kernel to which  $N_{to}$  and M has been assigned will be employed and equation (21) and equation (22) will be used in the calculation of  $N_{br}$  and  $N_{cr}$  respectively. This means that for every cracking operation during the experiment only shaft speed,  $N_{wh}$ ,  $N_{cu}$ , and the cracking time T will be recorded.  $N_{br}$  and  $N_{cr}$  will have to be calculated.

### Experimental Procedure

A constant volume cylindrical container of diameter of 0.174m and height 0.180m is used in measuring the palm kernel nut for the cracking experiment. The container was examined and found to contain an average of 640 palm kernel nuts weighing 3000grams at full load. Using this container 640 palm kernel nuts were used to test the developed palm kernel cracking machine when assembled with 3- arm hammer beater. Speed was determined by the use of a tachometer. The procedure is that each set of the 640 palm kernel nuts was cracked at the shaft speed of 800, 1000, 1200, 1400 and 1600 rpm and the total number of whole kernel nuts and total number of uncracked kernel nuts sorted. In each case the total mass of palm kernel nut fed into hopper together with the time taken by the cracked mixture to leave the chute was recorded. These data were then analyzed using Microsoft excel 210 of window 7.

### 3.0 RESULTS AND DISCUSSION

#### 3.1 Results

The result of the test using three –arm cracking shaft is shown below:



4(a) The cracked kernel shells using the 3-arm hammer beater awaiting sorting.

4(b) The un-cracked palm kernel shells

**Figure 4:** (a) the cracked palm kernel shells using the 3-arm hammer beater awaiting sorting, (b) the un-cracked palm kernel shells.

Other results are shown in Tables 1-2 and Figure 4. Table 1 is data obtained from the experiment carried out to determine the performance of the developed palm kernel nut cracking machine when assembled with three arm hammer beaters. Table 2 is the performance tests for the developed palm kernel nut cracking machine when assembled with three arm hammer beaters, and Figure 4 is the performance parameters variation with three arm hammer beater shaft speed.

**Table 1:** Data obtained from the experiment carried-out to determine performance of the developed palm kernel nut cracking machine when assembled with three arm hammer beaters

Shaft speed in rpm	No. of palm kernel nuts ( $N_{to}$ )	Mass of Kernels ( $M$ ) in (g)	Cracking Time ( $T$ ) in (s)	Number of whole nuts ( $N_{wh}$ )	Number of un-cracked nut ( $N_{uc}$ )	Number of broken nuts ( $N_{br}$ )	Number of cracked nuts ( $N_{cr}$ )
800	640	3000	36.56	428	33	179	607
1000	640	3000	35.56	541	12	87	628
1200	640	3000	34.18	475	6	159	634
1400	640	3000	33.86	305	5	330	635
1600	640	3000	30.14	210	2	428	638
Calculations: (1) $N_{br} = N_{to} - (N_{wh} + N_{uc})$ ; (2) $N_{cr} = N_{wh} + N_{br}$							

**Table2:** Performance tests for the developed palm kernel nut cracking machine when assembled with three arm hammer beaters.

Shaft speed in (rpm)	No. of palm kernel nuts ( $N_{to}$ )	Mass of Kernels (M) in (g)	Cracking Time (T) in (s)	Effective Capacity(EC) in (g/s)	Cracking efficiency (CE)	Performance efficiency (PE)	Split-nut loss % (SL)	Un-cracked nut loss % (UL)	Overall Efficiency (OE)
800	640	3000	36.56	82.06	94.84	66.88	27.97	5.16	63.43
1000	640	3000	35.56	84.36	98.13	84.53	13.59	1.88	82.95
1200	640	3000	34.18	87.77	99.06	74.22	24.84	0.94	73.52
1400	640	3000	33.86	88.60	99.23	47.66	51.56	0.78	47.29
1600	640	3000	30.14	99.53	99.38	32.81	66.88	0.43	32.60
Calculations: (1) $EC = M/T$ ; (2) $CE = (N_{cr}/N_{to}).100$ ; (3) $PE = N_{wh}/N_{to}.100$ ; (4) $SL = (N_{br}/N_{to}).100$ ; (5) $UL = (N_{uc}/N_{to}).100$ ; (6) $OE = CE \times PE$ .									

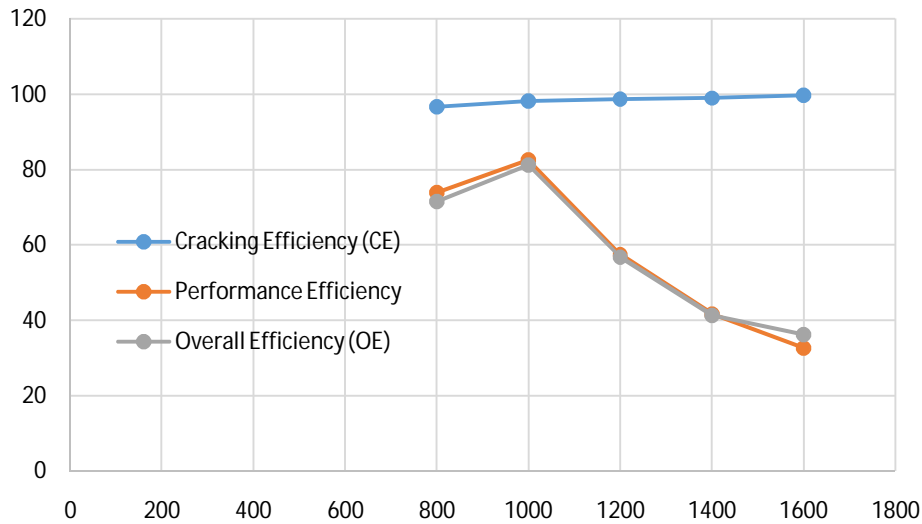

Figure 5. variation of performance and efficiency parameters against 3-arm hammer speed.

### 3.2 Discussion

Table 1 shows the data obtained from the experiment carried out to determine the performance of the developed palm kernel nut-cracking machine when assembled with 3- arm hammer beater. The data show that at the operational shaft speed of 800 rpm the cracking time of the palm nuts shell was 36.56 seconds. As the speed continued to increase the cracking time decreased and when it got to 1600 rpm, it took only 30.14 seconds to accomplish the cracking. At a shaft speed of 800 rpm the number of whole nuts was 428, as the operational speed increased to 1000rpm the number of whole nuts increased to 541 and then continued to decrease as the speed increased to 209 at 1600 rpm operational speed. At a shaft speed of 800 the number of un-cracked nut were 33. The number of uncracked nut decreased to 12 at 1000rpm and continued to decrease to 2 at 1600 rpm. At a shaft speed of 800 the number of broken nuts was 179. The number of broken nuts decreased to 87 at 1000 rpm and then continued to increase as the speed increased to 428 at 1600 rpm. At a shaft speed of 800 rpm the number of cracked nuts were 607. The number of cracked nuts then increased to 628 at 1000rpm and continued to increase as the speed increased to 638 at 1600 rpm. The inference of the result shows that the best operating speed for the 3- arm beater is 1000 rpm, although shorter cracking or processing time can be obtained at 1600 rpm (Akubo, 2002; Fashing *et al.*, 2017; Alade *et al.*, 2020). The observed inference agrees with the work of many researchers including Offiong (2024) who all agree that the best operating speed

for the 3-arm cracker hammer head is 1000 rpm this is because losses are minimized at this speed (Ologunagba, 2012; Udo *et al.*, 2015; Ibrahim *et al.*; 2016; Ibiyeye, *et al.*, 2022).

Table 2 further shows the performance tests carried out on the developed palm kernel nut cracking machine using 3- arm beater hammer head. As the operational speed was increased from 800rpm - 1600rpm the effective capacity in g/s was increased from 82.06 g/s at 800rpm to 99.53 g/s at 1600rpm. The increase in operational speed from 800- 1600rpm also affected the cracking efficiency which increased from 94.84 – 99.38. The performance efficiency however, increased from 66.88 at 800rpm and attained the highest value of 84.53 at 1000rpm and then continued to decrease to 32.81 at 1600rpm. The increase in operational speed showed that split-nut loss % at 800rpm was 27.97% this value dropped to 13.59 at 1000rpm and thereafter the split-nut losses increased with the increase in operational speed to the value of 66.88 % at 1600rpm. The increase in operational speed also affected un-cracked nut loss %, at 800rpm the value of un-cracked nut % was 5.16% as the speed continued to increase the un-cracked nut loss continued to decrease until it reached 0.43% at 1600rpm. The overall efficiency of operating the developed palm kernel nut cracking machine showed that as the operational speed was increased from 800rpm, the overall efficiency was 63.43, this increased to 82.95 at 1000 rpm and thereafter continued to decrease with an increase in shaft speed until it reached 32.60. The above trend which has been observed during the testing of the machine has equally, been observed by several other authors as noted in the references (Ologunagba, 2012; Ibrahim *et al.*; 2016; Ibiyeye, *et al.*, 2022). Udo *et al.*, (2015) developed a palm kernel nut cracking machine for rural use; performance evaluation of the machine indicated that the throughput of the machine increased from 10.91 to 38.00g/s as the speed increased from 800 to 2400 r/min. The performance efficiencies of the palm nut cracker machine developed were 93%, 94%, 95%, 94.5% and 94% at set speeds of 800, 1200, 1600, 2000 and 2400 r / min. Respectively. The analysed parameters are still overwhelmingly in favour of operating the 3- arm beater shaft at an operational speed of 1000 rpm.

Figure 5 is a further illustration of the graph of palm kernel cracking machine efficiency against the operational speed of the machine. The Figure is the graph of the performance parameters versus the variation of operational speed of the 3-arm hammer beater from 800-1600 rpm. The cracking efficiency continued to increase with the increase in shaft speed as seen in the graph. The plot of cracking efficiency is above that of performance efficiency and overall efficiency. Both the curves of the performance efficiency and the overall efficiency show that their values peaked at 1000 rpm and after, which they all gradually decreased as the shaft speed increased to 1600 rpm. The trend of the two curves clearly show that for best performance of the three arm hammer beater with the newly developed palm kernel cracker machine the operational speed should be 1000rpm. Many researchers in carrying out the performance analysis of their produced palm kernel nut cracking machine also observed these trends (Udo *et al.*, 2015; Taofiket *al.*, 2019; Ibiyeye, *et al.*, 2022; Offiong, 2024).

#### 4. CONCLUSION

The effects of a 3-arm hammer beater on the performance of a newly developed palm kernel nut cracker machine have been investigated. Interesting findings have been made and the following conclusions drawn from the study:

1. With the 3-arm hammer beater on the palm kernel nut cracking machine the shortest cracking time of 30.14 seconds occurred at 1600 rpm while cracking 3000g of palm kernel nuts.
2. With the 3-arm hammer beater on the newly developed palm kernel nut cracking machine the increase in operational speed led to an increase in number of whole nuts from 428 at 800rpm to 541 at 1000 rpm after which further increase in operational speed resulted in a decrease in number of whole nuts down to 210 at 1600 rpm.
3. As the speed increased to 800 rpm the number of un-cracked nut was 33. As the speed continued to increase the number of un-cracked nuts kept decreasing until it reached 2 at 1600 rpm
4. As the speed increased to 800 rpm the number of broken nuts was 179. As the speed continued to increase the number of broken nuts decreased to 87 and then continued to grow until it reached 428 at 1600 rpm
5. It was also discovered that as the operational speed continued to increase at 800 rpm the number of cracked nuts was 607 as the speed continued to increase the number of cracked nuts continued to increase until it reached 638 at 1600 rpm
6. The study clearly showed that for the 3-arm hammer beater on the newly developed palm kernel cracker machine, the best operational speed for cracking the palm kernel nut shells is 1000 rpm.
7. The effective capacity was 82.06 at 800 rpm as the speed continued to increase the effective capacity continued to grow until it reached 99.53 at 1600 rpm.
8. The cracking efficiency was 94.84 at 800 rpm as the speed continued to increase the cracking efficiency continued to increase until it reached 99.38 at 1600 rpm.
- 9 The highest performance efficiency of 84.53, the highest overall efficiency of 82.95, and the smallest value of split nut loss of 13.59% all occurred at the operational speed of 1000 rpm.
10. Un-cracked nut loss was 5.16% at 800 rpm, as the speed continued to increase the un-cracked nut loss continued to decrease until it reached 0.43% at 1600 rpm.

#### **Disclaimer (Artificial intelligence)**

Option 1:

Author(s) hereby declare that NO generative AI technologies such as Large Language Models (ChatGPT, COPILOT, etc) and text-to-image generators have been used during writing or editing of manuscripts.

Option 2:

Author(s) hereby declare that generative AI technologies such as Large Language Models, etc have been used during writing or editing of manuscripts. This explanation will include the name, version, model, and source of the generative AI technology and as well as all input prompts provided to the generative AI technology

Details of the AI usage are given below:

- 1.
- 2.
- 3.

## REFERENCES

- Adebayo, A. A. (2004). *Development and Performance Evaluating of a Motorized palm Nut cracking machine*. Proceeding of the Annual Conference, Nigeria Institution of Agricultural Engineers. Vol. 26, pp. 326-330.
- Akubuo, C. O., Eje, B. E. (2002). Palm kernel and Shell Separator. *Bio-systems Engineering*, 81(2), 193-199. Doi:<http://doi.org/10.1006/bioe.2001.0029>.
- Alade, E. I., Koya, O. A., and Omidiji, B. V., (2020). Development of a modified palm-nut cracker. *Agricultural Engineering International: CIGR Journal*, 22(1), pp. 204-214.
- Andoh, P. Y., Agyare, W. A., and Dadzie, J. (2015) selection of an ideal mesh size for the cracking unit of a palm kernel processing plant. *Journal of Science and Technology*. Vol. 30 No.3, pp. 109-118.
- Antia, O. O; Olosunde, W., and Offiong A. (2014). Determination of optimum moisture content of palm nut cracking for efficient production of whole kernel. *Nigerian Journal of Technological Development*, vol. 11, No. 2, pp. 27-30.
- Anyane, S. L. (1966) *The Oil Palm Industries of West Tropical Africa*. PhD Dissertation at Stanford University.
- Apeh, F. I., Yahaya, B. S., Achema, F., Fabiyi, M. O., and Apeh, E. S. (2015). Design analysis of a locally fabricated palm kernel shells grinding machine. *American Journal of Engineering Research*. 4(11), 1-7.

- Asadullah, M., Adi, A. M., Suhada, N., Malek, N. H., Saringat M. I., and Azdarpour, A. (2014) "Optimization of palm kernel shell torrefaction to produce energydensified bio-coal," *energy Conversion and Management*, vol. 88 pp. 1086-1093, 2014.
- Asoiro, F. U and Udo, U. C (2013). Development of motorized oil palm fruit rotary digester. *Nigerian Journal of Technology*, vol. 32. No 3, pp. 455-462.
- Babatunde, O. O. and Okoli, J. O. (1988). "Investigation into the effect of nut size on the speed needed for cracking palm nut in centrifugal nut cracker, "*Nigerian Journal of Palm and Oil Seeds*, vol. 9, pp. 84-88.
- Badmus, G. A. (1991) "NIFOR Automated Small Scale Oil Palm Processing Equipment, its need, development and effectiveness "Proceeding of PORIM INTERNATIONAL Palm Oil Conference, Nigeria 9-14 September 1990, Nigeria.
- Babatunde, O. O., Ige, M. T., and Makanjuola, G. A., (1988). Effect of sterilization on fruit recovery in oil palm fruit processing. *Journal of Agricultural Engineering Research*, vol. 41, Issue 2, pp. 75-79.
- Cornish, E. H. (1991). *Materials and Designer*, Cambridge University Press, Cambridge, 28-29.
- Emeka, V. E. and Julius .O.M. (2007). "Nutritional Evaluation of Palm Kernel Meat Types1. Proximate Composition and Metabolizable energy Values," *African Journal of Biotechnology* vol. 6, issue 21, pp. 2484-2486.
- Fashing, A. B; Disdrodola, O. S; and Hammed, I. A., (2017). Development and performance evaluation of and oil palm fruit digester, *Bioprocess Engineering* 1(2): 49-53. <http://www.sciencepublishinggroup.com/j/be> doi:10.11648/j.be.20170102.13.
- Food and Agricultural Organization (2002) Statistical Yearbook. *Journal for Food and Agricultural Organization*, 2/2.
- Food and Agricultural Organization (2004) Statistical Yearbook. *Journal for Food and Agricultural Organization*, 2/2.
- Ibiyeye, D., Dlunloyo, O., Aderemi, A., Emmanuel, I., Akala, A., and Owolola, O. (2022). Design and development of a palm kernel nut unit. *Technology audit and Production Reserves*, 1/3(63), pp. 30-44, doi:http://doi.org/10.15587/2706-5448.2022.253931.
- Ibrahim, I. D., Jamiru, J., Sofuwa, O., and Onuoha, O. J., (2016). Design and performance evaluation of horizontal-shaft palm kernel cracking machine. *Proceeding of Covenant University-3<sup>rd</sup> International Conference on African Development*. Issues. pp. 337-3341.
- Mba, O. I., Dumont, M. J., Ngadi, M. (2015) "Palm Oil Processing, characterization and utilization in the food industry – A review, "*Food Bioscience*, Vol. 10, pp. 26-41.

- Mosarof, M. H., kalam, M. A., Masjuki, H. H., Ashraful, A. M., Rashed, M. M., Imadadul, H. K., Monirul, I. M. (2015). "Implementation of palm biodiesel based on economic aspects, performance, emission, and wear characteristics, Energy," Conversion and Management, Vol. 105 pp. 617-629.
- Ndegwe, N. A., (1987). The oil Palm in Rivers State of Nigeria. Pp: 103-104.
- Norazura, A. M. H. (2017). Usage of palm oil, palm kernel oil and their fractions as confectionery fats. *Journal of Oil Palm Research*, 29(3), 301-310. Dio: <http://dio.org/10.21894/jopr.2017.2903.01>.
- Offiong, A. (2024) Design and Production of Palm Kernel Cracking Machine, Undergraduate Project work in the Department of Mechanical and Aerospace Engineering, University of Uyo-Nigeria for the award of B.Eng. Degree.
- Okoli, J. U. (2022). Optimum during time for palm nuts for efficient nut cracking in small scale oil palm fruit processing mills. *Global Journal of Engineering Research*. Vol. 2, No. 1, 2003, pp. 7-10.
- Ologunagba F. O., (2012). Design and Evaluation of a Horizontal shaft palm nut cracking machine. *Journal of Engineering and Applied Science*, Vol. 4, pp 81.
- Taofik, O. K; Adesola, O. K; Abu, R., and Olantunde, A. N., (2019). Development and performance evaluation of small-scale palm kernel cracker. *International Journal of Mechanical and Civil Engineering*, vol 2, Issue 1, pp. 15-27.
- Udo, S. B., Adisa, A. F., Ismila, S. O and Adejujibe, S. B., (2015). Development of palm kernel nut cracking machine for rural use. *Agric Eng Int: CIGR Journal* 17(14): 379-388.