

Structure design and analysis of welding robot manipulator

Abstract : Welding robot is a multi-degree-of-freedom robot. As a part of the robot, the manipulator is an important part to complete the welding operation directly. The structure design of the large arm, small arm and welding torch of the welding robot manipulator is carried out, and the structure of the manipulator is designed by pneumatic drive design. The results show that the designed manipulator meets the accuracy requirements and is completed by combining the swing cylinder, the lifting cylinder and the telescopic cylinder.

Keywords: welding robot ; mechanical arm ; pneumatic circuit

Introduction

Due to the poor welding construction environment, high labor intensity of welders and high difficulty of welding technology, traditional manual welding is difficult to meet the needs of engineering production. After the continuous improvement of traditional manual welding technology, automatic welding technology was born. The use of welding robots can have a significant impact on the improvement of welding accuracy as a welding work efficiency to some extent. At the same time, it can also reduce the work risk in the whole process of construction execution, and can also achieve the purpose of reducing production costs and strengthening production efficiency^[1]. The application of welding robots can also reduce the demand for the ability of operators to manipulate. According to the report of relevant documents, industrial robots can be used in industrial manufacturing and industrial production all over the world has more than one million. As a major member of industrial robots, welding robots^[2] account for more than 35 % of the total number of industrial robots in all industries. With the continuous improvement of equipment technology, it has been able to cope with about 70 % of welding operations^[3].

In this paper, a welding robot based on welding manipulator is designed. The designed manipulator includes a large arm, a small arm and a waist seat. The power system of the robot is designed by cylinder drive, and the appropriate pneumatic control module is selected.

The welding robot designed by the author is shown in the figure.

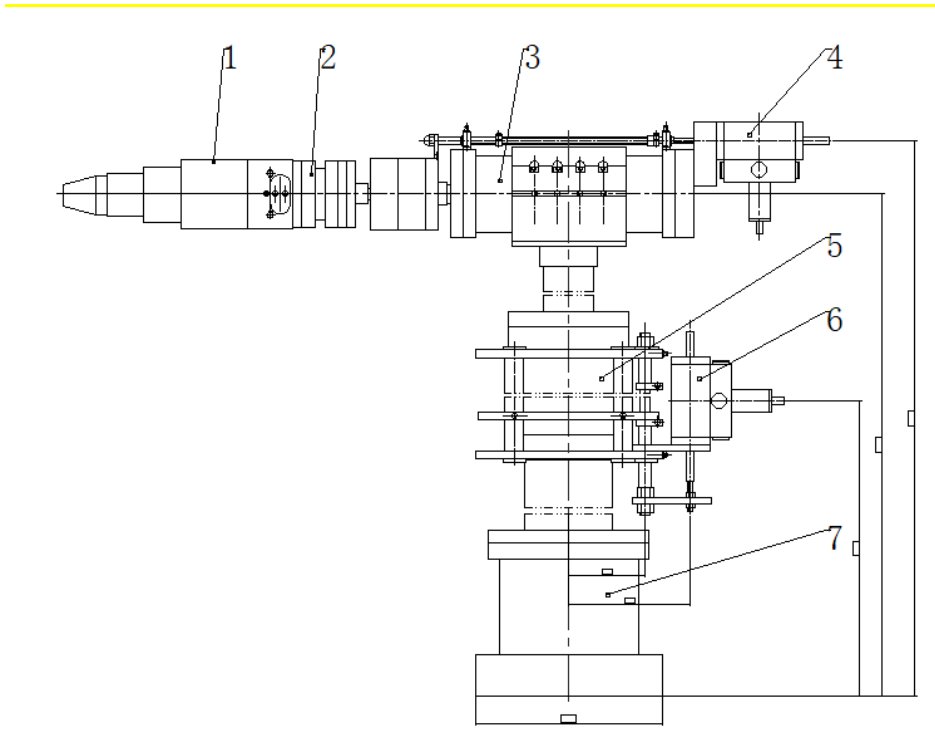

Fig.1 Main view of welding manipulator shape

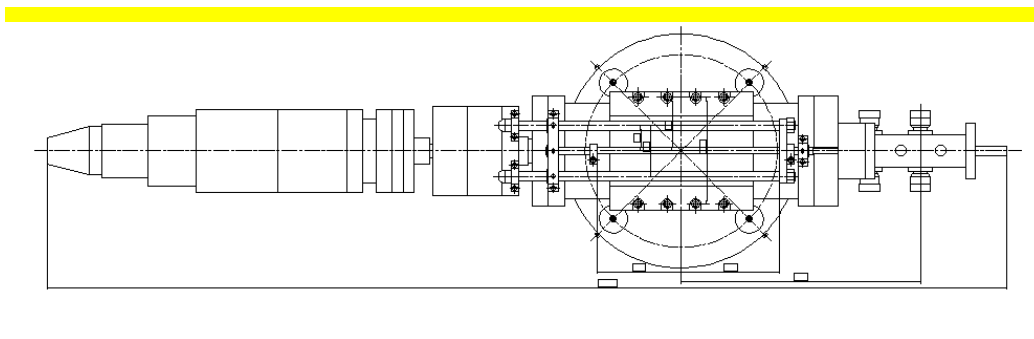

Fig.2 Top view of welding manipulator shape

Table 1 : Mechanism Parts

1	welding torch
2	welding torch fixture
3	small arm telescopic cylinder
4	hydraulic buffer for arm telescopic
5	large arm lifting cylinder
6	hydraulic buffer for arm lifting
7	arm swing cylinder

1. Overall structure design

The welding operation robot^[4] based on the welding manipulator is a special equipment that combines the cylinder-driven manipulator^[5] and the welding torch to effectively complete the welding operation. The welding manipulator is composed of waist seat, swing cylinder, big arm, lifting cylinder, small arm, telescopic cylinder, welding gun fixture and welding gun.

1.1 The composition of the mechanical arm

The manipulator is mainly composed of these four parts, which are composed of brain control, body drive, arm execution and arrival detection^[6]. Therefore, the mutual connection between the various systems has formed the block diagram 3.

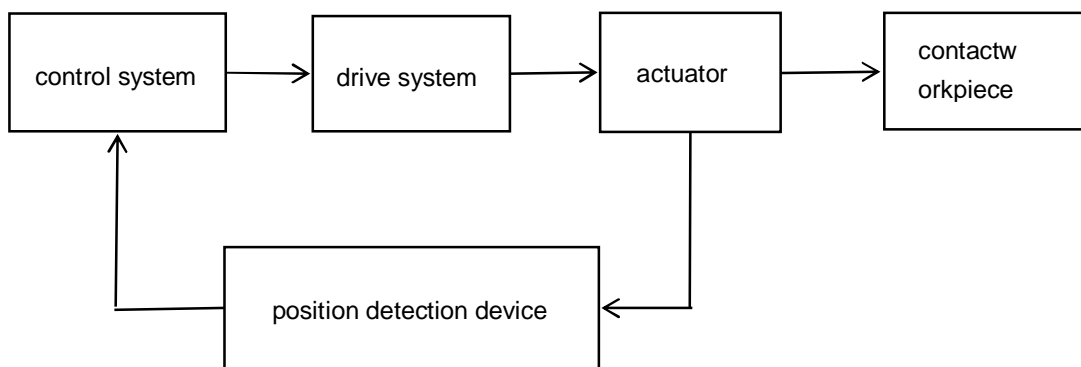

Fig.3 The composition block diagram of the manipulator

Executing agency

The actuator of the manipulator is usually composed of joints driven by motors. Each joint contains components such as motors, reducers, and encoders, which are used to control and execute the movement of the manipulator. It includes components such as arms and columns.

(1) Design of the arm

The arm is a part used to support the palm to complete the task. The main purpose of the arm is to assist the welding gun to accurately align the weldment, and to align the welding gun to the point that needs to be welded according to the accuracy required for the operation. The arm of industrial robot is to combine the mechanical parts (such as cylinder, oil cylinder, transmission rack, connecting rod, spiral and cam mechanism, etc.) acting on the arm of the actuator with the actuator source (such as hydraulic, pneumatic or motor, etc.) to realize the various motion functions of the manipulator. While the arm is lifting or stretching, it needs to have a guiding device to stop the steering around its axis line, so as to ensure the movement of the welding torch in the accurate direction. The bending moment and torsion moment on the

arm of the guiding device, as well as the instantaneous inertial dynamic moment generated by the propulsion and braking during the rotation of the arm, are borne by the guiding device, and the pressure condition of the moving element is simple. The guide devices used more frequently are : single cylinder, double cylinder, four cylinder and V-shaped groove, dovetail groove and other guide structure forms.

(2) Column design

The column can support the arm and is subordinate to a part of the arm. The arm is completed with the assistance of the column when turning and lifting. Robots are designed to be stable and immobile pillars. If there are special needs, sometimes they can also be moved horizontally or mounted on wheels.

(3) Design of frame

One of the basic components of the manipulator includes the base, which can play the role of bearing connection. The components and drive systems of the manipulator actuator are assembled on the base.

1.2 Drive system

The drive system is composed of a power source, a control adjustment device and an auxiliary device, which can promote the movement of the industrial manipulator actuator. The general drive system includes four forms : hydraulic transmission system, pneumatic transmission, motor transmission system and gear (belt) transmission.

1.3 Control system

The control system is the brain part of the industrial robot, which controls all the activities of the industrial robot. At present, most of the control of industrial manipulator is completed by PLC control system. The control system has two kinds of electrical control and jet control. It can make the manipulator run normally according to the program, and can also store the operation instructions (such as the order of each action, the path of action, the speed of action and the time) that the operator loses to the manipulator. At this time, the program of the control system sends signals to the arm and the welding gun, and the action of the manipulator can be monitored at the critical time. When the program is wrong or fails, the task will be stopped immediately. Firstly, according to the function of the control system, the suitable PLC model is selected, and the I / O port is allocated according to the PLC model and the required function, and the external wiring diagram of the PLC is drawn to complete the hardware part design. Then according to the required control system functions, complete the software part. The main functions include initialization, automatic, manual, emergency stop and reset.

In the design of this project, the quality of the welding torch is about 0.5kg, and considering the machining accuracy of the welding manipulator, the structure should be simplified as much as possible to reduce the cost and further improve the design level. The designed manipulator needs three kinds of movements in the task execution, and the waist rotates. Big arm lifting ; the arm stretches. Considering comprehensively, it can be concluded that the number of degrees of freedom of the manipulator is 3, so this manipulator is used. The design of this topic first carries out the spatial rotation of the design waist, then carries out the vertical lifting

of the design arm, and finally carries out the horizontal expansion of the design arm.

1.4 Drive selection

1. Motor drive

Usually, the motor drive is selected in the case of high control accuracy [10]. In order to meet the large torque output capability, the AC / DC motor can be completed, because its inertia is relatively large, usually need to be equipped with a deceleration device ; compared with ordinary motors, servo motors are usually applied to high-precision equipment, because the torque output is relatively small, and it is easier to complete higher-precision position control ; stepper motors are often used in open-loop control systems because their accuracy control is not as good as servo motors.

Features :

- (1) High control accuracy ;
- (2) It can meet the demand of torque output in a large range ;
- (3) The operator requirements are relatively high, the control is more complex, usually need to be equipped with PLC and other control components ;
- (4) There are too many components in the whole drive system structure, and the maintenance technology and cost requirements are high ;
- (5) The cost is relatively high.

2. Hydraulic drive

The selection of hydraulic oil as the driving medium is hydraulic drive, which can complete the control of fast and high precision. At the same time, compared with the motor drive, it does not need to be equipped with a deceleration device. The hydraulic oil itself can be used as a hydraulic buffer, the output force and power are relatively large, and the work is stable and reliable. It is usually applied to large and heavy equipment, such as rollers, muck trucks and other large machinery.

Features :

- (1) The hydraulic oil of transmission medium has small compressibility, high control precision and quick response.
- (2) can produce a larger thrust ;
- (3) The self-lubricating effect of oil can greatly increase the service life of hydraulic equipment ;
- (4) The whole system covers a relatively large area, and is prone to fire and other dangers at high temperature ;
- (5) Insurmountable hydraulic oil leakage defects ;
- (6) Good precision, quality standards of hydraulic components, manufacturing cost is high, the whole drive cost is unexpected.

3. Pneumatic driving

Pneumatic drive is a clean driving method. Its working medium is compressed gas, the clean cost is low, the reaction is relatively fast, the operation is convenient, the compressed gas is more convenient than the compressed liquid, but the stability is poor, and there is also no accurate speed control and position accuracy control.

Features :

- (1) The transmission medium is clean and pollution-free, low cost ;

- (2) The control system is easy to operate ;
- (3) unified by the air compressor station gas supply, covers an area of space and quality are relatively small ;
- (4) The accuracy of position limit and speed limit is not high ;
- (5) The production cost of pneumatic components is low, and the cost of the whole system is relatively low.

From the convenient use of the supply of gas source, the low cost and the relatively low accuracy of the demand, it is better to adopt the method of pneumatic drive to promote the driving mode of the mechanical arm.

2. Structural design of the manipulator

After the overall design of the welding manipulator, it is necessary to accurately design the waist base, big arm, small arm and other parts of the manipulator in turn.

2.1 Design scheme of mechanical arm waist base

The power drive of waist rotation is selected as the swing air cylinder in this design^[7]. Considering that the waist seat is the most basic part of the robot, the control of the manipulator is not very accurate, and all the swing pneumatic cylinders are selected to realize the rotary motion of the waist.

This topic uses a rack and pinion swing cylinder.

The rack and pinion swing cylinder^[8] is shown in Fig.4, which allows the piston to perform linear reciprocating motion in the cylinder. The engine can convert thermal energy into mechanical energy by thermal expansion and contraction of air, and increase pressure by compression in the compression cylinder.



Fig. 4 Gear rack swing cylinder

The thrust and tension required on the piston rod are determined by the force required for the work. When selecting the cylinder, you should leave room for selection. If the cylinder is too small, the output can not reach, the cylinder can not be used normally ; however, if the cylinder is too large, the cylinder is bulky, the cost is high, and the output is overflowed, it will cause waste of resources.

The output torque formula of the swing cylinder is :

The maximum output force can be calculated according to the effective piston area and the maximum working pressure :

$$F = P_{\max} * S = 213N \text{ (2-1)}$$

F in (2-1) is the maximum output force (N) of the cylinder ;

P_{\max} is the maximum cylinder pressure (Pa) ;

S is the contact piston area (m^2) in the cylinder.

The torque of each part and the maximum angle θ are determined by the diameter R of the rotating device of the cylinder piston rod :

$$T = F \times R \text{ (2-2)}$$

In Equation (2-2), T is the torque of each part (N · m) ;

r is the hub diameter (mm) inside the transmission device.

$$\theta = L / R \text{ (2-3)}$$

L cylinder piston rod motion displacement (mm) in (2-3) ;

θ is the swing angle of each part.

From the hub diameter of the transmission device $R = 20mm$, we can get $T = 2.13N \cdot m$, $\theta \approx 90^\circ$.

In this design, the rack and pinion three-position swing table MSZB-50A of SMC is selected, in Figure 5 below. This device works at an atmospheric pressure of 0.5MPa. From both sides to the midpoint, the calculated output torque is $4.84N \cdot m > 4.27N \cdot m$, and from the midpoint to both sides, the calculated output torque is $4.75N \cdot m > 4.27N \cdot m$. Screws can be used in many areas to mobilize the angle range between 0 and 190 degrees. The adjustable range is about $\pm 10^\circ$, the fixed rotation speed is about 0.2 to 1.0 s / 90° , the maximum atmospheric pressure it can accept when working is 1 MPa, the minimum atmospheric pressure is 0.2 MPa, the maximum longitudinal pressure is 451 N, and the maximum lateral pressure is 314 N. According to the above calculation to meet the requirements.

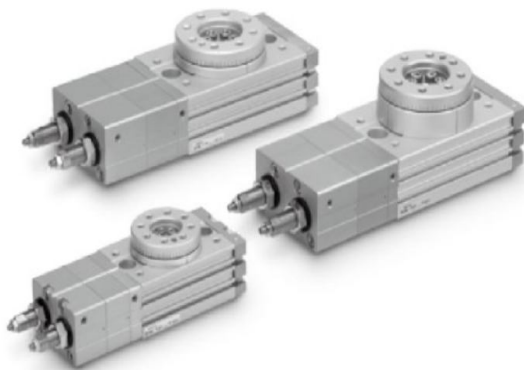

Fig. 5 SMC three-position swing table MSZB-50A

(2) Selection of keys

The key selection is carried out under the national standard. According to the shape and size of the keyway on the workpiece and what it can do, the key is selected^[9], and then the strength of the selected key is checked. The keys are made of qualified steel under the national standard. Their tensile strength is 45 steel.

In the design of the mechanical arm, the keys are the keys of the reducer, that is, the ordinary

round head A type.

2.2 The design scheme of the large arm of the manipulator

The movement mode of the large arm of the manipulator is the vertical lifting movement^[10], and the movement mode of the small arm is the horizontal expansion movement. The adjustment of the two arms is pneumatically driven, because the design takes into account the dynamic performance of the manipulator and the stability and safety of the movement.

When the operation of the big arm is carried out, the linear motion of the lifting is completed in the vertical direction. The piston rod inside the cylinder is used to move back and forth to drive the lifting of the small arm structure and become higher. The lower part of the big arm is installed with the swing cylinder, and the upper part is installed with the small arm. The detailed composition is shown in Figure 6.

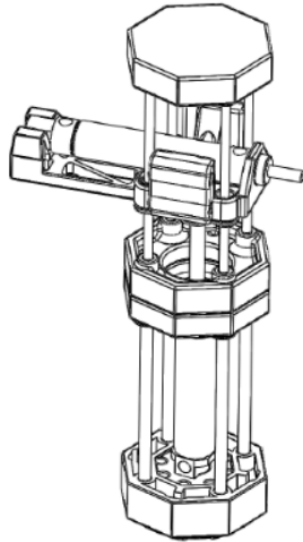

Fig. 6 Lifting structure of large arm of manipulator

It can be known from the components that the big arm lifting cylinder bears everything of the small arm and the quality of the welding gun when it bears the maximum load. It is better to use the maximum mass to calculate : $F = 70N$.

Calculation of inner diameter D of lifting cylinder

When it is working, it is mainly to make the whole higher, afraid to encounter some fixed things.

Therefore, its main output is thrust. When calculating the inner diameter, $d / D = 0.5$ can be taken. Using this formula, $P = 0.5 \text{ MPa}$, $\eta = 0.3$ can be calculated :

$\Rightarrow D = 45 \text{ mm}$, piston rod thickness $d = 16 \text{ mm}$, distance $S = 350 \text{ mm}$. The cylinder model is SC40-300-S.

Checking calculation of cylinder

The cylinder of the model SC50-300-S selected in this design needs to complete the operation at an atmospheric pressure of 0.5 MPa . At the same time, the output thrust is 628.0 N , and the output tension is 527.5 N , which is greater than the load and can be used normally.

2.3 Design scheme of the manipulator arm

The movement of the lower arm is a linear movement in the horizontal direction, so a movement that can act on two cylinders and a stick-shaped light rod is selected in this design to make the movement of the lower arm. In order to make up for the disadvantage that only the piston rod can not reach the workpiece position, the cylindrical optical axis can be used to increase the expansion range. According to the production needs, select the type of cylinder. In order to reduce the moment of inertia of the whole arm to the rotary center, the volume and mass of the cylinder need to be considered.

The small arm mainly moves back and forth in the horizontal direction. The sliding friction force F of its power device during operation can be calculated as :

$$F = \mu mg \quad (2-4)$$

In Equation (2-4), m is the load mass on the telescopic structure of the arm, and the maximum mass is about 7000g ; g (10m/s^2) is the known acceleration of gravity ; the friction coefficient μ is 0.1 here. Substituting them into Eq. (2-4) can be calculated : $F = 5\text{N}$.

When the cylinder is moving on the outside side, the calculation formula of the inner diameter D of the cylinder is :

$$D = \sqrt{\frac{4F_1}{\pi P \eta}} \quad (2-5)$$

In Equation (2-5), D is the inner diameter of the cylinder (mm) ;

F_1 is the load in motion (working load) (N) ;

P is the first time to determine the size of the pressure, usually within 0.5 MPa to 1 MPa ;

η generally refers to the total mechanical efficiency, frequent multi-time movement, choose between 0.3 to 0.5 ; when rarely exercise, the best value is generally selected in the range of 0.7 to 0.85.

Inside the rod to move the other part of the load need to do the work is :

$$D = \sqrt{\frac{4F_2}{\pi P \eta} + d^2} \quad (2-6)$$

In Eq. (2-6), F_2 is the tension of piston rod (N) ;

d Piston rod diameter (mm). The d / D is about between 0.16 to 0.5.

Substitute d / D between 0.16 to 0.5 into the formula (2-6) and get :

$$D = (1.01 \sim 1.15) \sqrt{\frac{4F_2}{\pi P \eta}} \quad (2-7)$$

The calculation of cylinder inner diameter D :

The inner diameter of the cylinder can be obtained from the previous series of calculations.

Take $d / D = 0.5$, $P = 0.5$ MPa, $\eta = 0.3$ into the formula to calculate :

$$D = 1.15 \sqrt{\frac{4F_2}{\pi P \eta}} = 1.15 \sqrt{(4 * 5) / (3.14 * 0.5 * 10^6 * 0.3)} \approx 7.5$$

It can be obtained from the reference of this design that $D = 40$ mm, the diameter of the piston

rod $d = 12$ mm, and the distance $S = 250$ mm. The type of cylinder selected is SC40-250-S. Check telescopic cylinder^[11];

The selected model in the design is SC40-250-S. When the cylinder works, the driving force is 402.0 N, and the pulling force is 345.0 N. It is necessary to ensure that it must be operated at a gas pressure of 0.5 MPa. The design data is normal and the next step can be carried out.

3 Design of each degree of freedom driving system of manipulator

When the manipulator is designing the pneumatic control^[12] module, the design of this part affects whether the whole robot can work stably and normally. Therefore, it is very important to have a reasonable drive module. This chapter is based on how the mechanical arm works to design such a pneumatic drive module system, which allows the mechanical arm to perform normally during swing, lifting, and stretching, providing power. The design of this system is not only to enable each part to successfully complete the work, but also to complete them while making the manipulator more durable, convenient and stable. In these aspects of the construction of the loop, the choice of pipe fittings, the steps of operation, this can improve the overall versatility, insurance, stability and utilization.

In order to be able to complete the movement of the entire set of manipulators and the realization of certain functions, as well as the mutual cooperation between each component, a reasonable drive circuit should be designed^{[13][14]}. The movement of the structure is mainly realized by the reciprocating motion of the piston, and the direction is controlled by the electromagnetic directional valve. The gas in the air pump is used as the medium to transport the gas medium to the whole system through the triplet to ensure the normal progress of each step. The speed regulation process is realized by the throttling speed control valve. The schematic diagram is shown below.

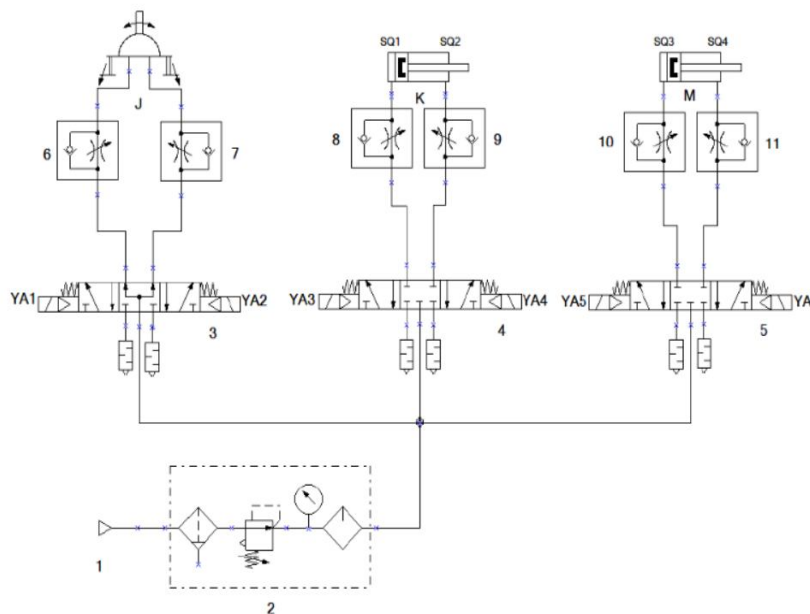

Fig.7 Mechanical arm pneumatic drive system circuit

Table 2 : Pneumatic Element

1	gas source
2	pneumatic triple piece
3、4、5	three five-way solenoid valve
6、7、8、9、10	one-way throttle valve
J	three swing table
K	lifting cylinder
M	telescopic cylinder
SQ	magnetic switch

The system circuit mainly includes three three-position five-way solenoid valves^[15] and six one-way throttle valves^[16], so as to realize the control of seven six, the movement of the cylinder, the rotation of the various azimuths of the manipulator, the control of the rope and the speed, which is of great help to the optimization of the structure.

3.2 Pneumatic circuit operation is completed

Understand a series of actions of the manipulator, and plan out the action direction and order of the cylinder. Pneumatic system^{[17][18][19][20]}, the main completion of the operation process is the welding process.

During the process, the action process of the cylinder is as follows : telescopic cylinder M extended → lifting cylinder K extended → three pendulum J clockwise rotation to the median → welding torch contact weldment → welding torch stop working → telescopic cylinder M retracted → lifting cylinder K retracted → welding torch cooling. Through the analysis of the drive system circuit in Figure 7, it can be seen how the gas path completes the whole operation process. Due to the excessive number of actions in the entire process, the cylinder has been doing back and forth movement. The following is an introduction to all the actions of each cylinder used in this design :

(1) The movement of telescopic cylinder M

After receiving the electrical signal on the YA5 side of the three-position five-way solenoid valve 5, the things in the valve body swing to the left. The pressure in the gas chamber becomes larger, and the piston extends out ; after receiving the electrical signal on the YA6 side of the three-position five-way solenoid valve 5, the things in the valve body swing on the right side, the pressure in the gas chamber becomes larger, and the piston shrinks back.

(2) The movement of lifting cylinder K

After receiving the electrical signal on the YA3 side of the three-position five-way solenoid valve 4, the inside of the valve swings to the left. The pressure in the gas chamber becomes larger, and the piston protrudes ; after receiving the electrical signal on the YA4 side of the three-position five-way solenoid valve 4, the things in the valve body swing on the right side, the pressure in the gas chamber becomes larger, and the piston shrinks back.

Conclusion

This manipulator is a welding manipulator, and the pneumatic manipulator is selected. Each actuator of the manipulator, including : the rotation of the waist, the lifting of the big arm and the expansion of the small arm. A fixture is used between the welding torch and the arm. The manipulator has three kinds of movements when it is working, namely, the rotary movement of the waist, the lifting movement of the big arm and the telescopic movement of the small arm. Considering comprehensively, the number of degrees of freedom of the manipulator is 3, with one rotational degree of freedom and two linear degrees of freedom. The pneumatic manipulator is designed, which is characterized by simple structure, large range of arm motion and high positioning accuracy. Considering that the waist seat is the first degree of freedom link of the welding robot, which has a great influence on the final accuracy of the manipulator, the gear rack swing cylinder is used to realize the waist rotation movement. After analyzing the specific work requirements, comprehensive consideration of various factors. The movement of other parts of the manipulator also requires a certain positioning control accuracy, so the combination of lifting cylinder and telescopic cylinder is used to achieve the completion.

Disclaimer (Artificial intelligence)

Option 1:

Author(s) hereby declare that NO generative AI technologies such as Large Language Models (ChatGPT, COPILOT, etc) and text-to-image generators have been used during writing or editing of manuscripts.

Option 2:

Author(s) hereby declare that generative AI technologies such as Large Language Models, etc have been used during writing or editing of manuscripts. This explanation will include the name, version, model, and source of the generative AI technology and as well as all input prompts provided to the generative AI technology

Details of the AI usage are given below:

- 1.
- 2.
- 3.

REFERENCES

-
- ^[1] Zhang Fulin, Huo Ping, He Yajie. Structure design and path planning of mobile welding robot [J]. Machine and hydraulic, 2024,52 (09) : 36-43.
 - ^[2] Feng Jing, Mo Mouyi, Jin Yu, et al. Design and fabrication of multi-functional small six-axis manipulator [J]. Electromechanical engineering technology, 2024,53 (04) : 50-53 + 146.
 - ^[3] Feng Chuanzhi, Luo Yu, Xu Yaobo, etc. Structural design and kinematics analysis of pipeline all-position welding robot [J / OL]. Electromechanical engineering, 1-13 [2024-05-24]. <http://kns.cnki.net/kcms/detail/33.1088.TH.20240408.1329.005.html>.
 - ^[4] Luo Jiangnan, Li Jianping, Liu Lei, et al. Structure design and motion analysis of drilling manipulator [J]. Hydraulic and pneumatic, 2023,47 (12) : 81-90.
 - ^[5] Guilin, GuJin, Zhang Bin, etc. Structural design and analysis of a five-degree-of-freedom pruning robot [J]. Chinese Journal of Agricultural Machinery Chemistry, 2023,44 (03) : 191-198. DOI :

10.13733 / j.jcam.issn.2095-5553.2023.027.

^[6] Wang Weibing, Zhang Ji, Xu Qian. Kinematics analysis of a six-axis welding manipulator [J]. Journal of Harbin University of Science and Technology, 2019,24 (06) : 125-131.DOI : 10.15938 / j.jhust.2019.06.019.

^[7] Bai Zongchun, Li Xiaoning. Positioning control strategy and experimental study of swing servo cylinder [J].Machine tool and hydraulics, 2014,42 (23) : 79-83.

^[8] Shi Lu Bing, Zhang Zhihong, Yan Xiaoqing, etc. Research on operating load and fatigue life of gear and rack of Three Gorges ship lift [J].Journal of Mechanical Engineering, 2024,60 (05) : 119-129.

^[9] Dong Feng, Zhang Yonghui. Design of coaxial double output planetary gear reducer [J]. Modern manufacturing technology and equipment, 2023,59 (04) : 95-97.DOI : 10.16107 / j.cnki.mmte.2023.0224.

^[10] Gao Qiang, Wang Wei. Structural design of pneumatic manipulator [J].Modern manufacturing technology and equipment, 2016, (03) : 19 + 38.DOI : 10.16107 / j.cnki.mmte.2016.0258.

^[11] Zhao Yunwei, GengDexu, Liu Xiaomin, et al. Kinematics analysis and experiment of pneumatic flexible fruit and vegetable picking manipulator [J]. Journal of Agricultural Machinery, 2019,50 (08) : 31-42.

^[12] Wang Tao, Zhu Aidong, Chen Jinbing, et al. Structural design and control of pneumatic parallel robot [J].Hydraulic and pneumatic, 2019 (02) : 55-60.

^[13] Liu Wenting. Application of step module method in the design of full pneumatic circuit [J].Hydraulic and pneumatic, 2021,45 (11) : 128-133.

^[14] Dai Wei, Zheng Wu. Modular design of step motion control for pneumatic control loop [J].Technological innovation and application, 2019, (04) : 92-93.

^[15] Chen Gang. Design of gas-liquid linkage double cylinder control circuit for lifting platform [J].Coal mine machinery, 2015,36 (12) : 37-38.DOI : 10.13436 / j.mkjx.201512015.

^[16] Chen Cheng, GuJin, Liu Yong. Hydraulic system design of power steering assembly comprehensive performance test bench [J].Hydraulic and pneumatic, 2021,45 (09) : 158-163.

^[17] He Daokun, Li Ming. Manipulator pneumatic joint flexible grasping control [J].Mechanical science and technology, 2023,42 (02) : 198-202.DOI : 10.13433 / j.cnki.1003-8728.20230058.

^[18] GuoLianjin, Li Junjie. Pneumatic manipulator control system design and multi-software co-simulation [J]. Machine tools and hydraulics, 2021, 49 (19) : 94-99.

^[19] Zhu Jing. Design of Pneumatic Manipulator Control System Based on PLC [J].Agricultural Technology and Equipment, 2024, (03) : 27-29 + 32.

^[20] Zhao Zhongyu, Wang Dehong. Design and research of pneumatic manipulator based on single chip microcomputer control [J].Modern manufacturing technology and equipment, 2020 (05) : 179-180.DOI : 10.16107 / j.cnki.mmte.2020.0510.