

Original Research Article

Monitoring the Air-Fuel Ratio (AFR) of a biomass gasification process with an Arduino Uno 3 and a narrow band Lambda oxygen sensor

Abstract

The Air-Fuel Ratio is one of the keys parameters for driving the gasification process. Monitoring of oxygen percentage in flue gases is one of various ways of controlling efficiency and emissions of industrial combustion. Biomass **gasification** is a thermochemical degradation of the biomass that is accomplished with the Air-Fuel Ratio less than the **stoichiometric** one that is used in the combustion.

Unfortunately, flue gases analyzers in combustion processes are expensive and not accessible to small scale industries. This is particularly true in **developing** countries. The Lambda sensor used in the automotive **industry** is an oxygen sensor which controls the electronic injection of the modern internal combustion vehicles.

The aim of this study is to present one simple method of measuring the oxygen concentration and calculate the Air-Fuel Ratio in synthesis gas produced by a downdraft biomass gasifier by the use of an Arduino Uno 3 microcontroller and an automotive Lambda sensor. This method use the voltage signals **developed** by a heated 4 wires Lambda sensor and the **Nernst** Equation to calculate oxygen concentration in the producer **gas** and derive the Air-Fuel Ratio.

Results presented in this article show that this **method** is a simple and **cost-effective** way to monitor Air-Fuel Ratio in a biomass gasifier.

Keywords : Air-Fuel Ratio, Biommas, Gasification, Lambda sensor, Arduino

1. Introduction

Biomass gasification is used very little in Burkina Faso, although it has proven to be one of the most efficient methods for converting biomass into thermal and electrical energy. Despite the abundance of waste of agricultural, plant and household origin, the large-scale recovery of this conversion process is very little developed in Burkina Faso. [1], [2]. In a bibliographic review made in 2014, it was established that gasification of waste may be an interesting alternative for waste **valorization** in Burkina Faso [3]. Other studies on the development of biomass energy in Africa agree with the main conclusions of that review [4], [5], [6].

The equivalence ratio (ER) of a system is defined as the ratio of the hydrocarbon-to-oxidizer ratio to the stoichiometric hydrocarbon-to-oxidizer ratio **which** can be expressed with equation (1) below :

$$ER = \frac{(fueltooxidizeratio)_{act}}{(fueltooxidizerratio)_{sto}} = \frac{[m_{fuel}/(m_{oxy})]_{act}}{[m_{fuel}/(m_{oxy})]_{sto}} = \frac{[n_{fuel}/(n_{oxy})]_{act}}{[n_{fuel}/(n_{oxy})]_{sto}} \quad (1)$$

In equation (1), m represents the mass, n represents number of moles. Subscripts *act* and *sto* refer to actual and stoichiometric ratios respectively for the corresponding mass or mole fractions.

According to Vaclav et al. [7] : if air is used as the oxidizer, equation (1) can be rewritten as follow :

$$ER = \frac{(fueltooxidizerratio)_{act}}{(fueltooxidizerratio)_{sto}} = \frac{[m_{fuel}/(m_{air})]_{act}}{[m_{fuel}/(m_{air})]_{sto}} = \frac{[n_{fuel}/(n_{air})]_{act}}{[n_{fuel}/(n_{air})]_{sto}} \quad (2)$$

Air Fuel Ratio is given by equation 3 below :

$$AFR = \frac{m_{air}}{m_{fuel}} = \frac{\rho_{air} \cdot V_{air}}{\rho_{fuel} \cdot V_{fuel}} = \frac{1}{d} \frac{V_{air}}{V_{fuel}} \quad (3)$$

Where ρ is the, V is the volume, d is the density of the fuel against air.

Comparing equations 3 and 2, we see that ER is the ratio of the stoichiometric AFR to the actual AFR.

Commercial Lambda sensors give the excess oxygen in the flue gas. Therefore, we can compute the AFR from the output of the Lambda sensor.

In an experimental study on air gasification of polypropylene, Xiao et al. [8] studied the effect of the ER and found that equivalence ratio appeared to have a significant effect on the reactor temperature and other gasification results. The increase of the equivalence ratio favored the formation of the fuel gas and decreased the formation of the tars and char. Other authors obtained similar results [9], [10], [11]. Coming out as a summary, the work done by Vaezi et al. [12] used the thermochemical equilibrium modeling to predict the performance of a heavy fuel oil gasifier. Their model combined both the chemical and thermodynamic equilibriums of the global gasification reaction in order to predict the final syngas species distribution. They compared the results of their simulations with reported experimental measurements through which their numerical model was validated. They found that the ER exhibit an optimum value respective to producer gaz yield as depicted on figure 1 below:

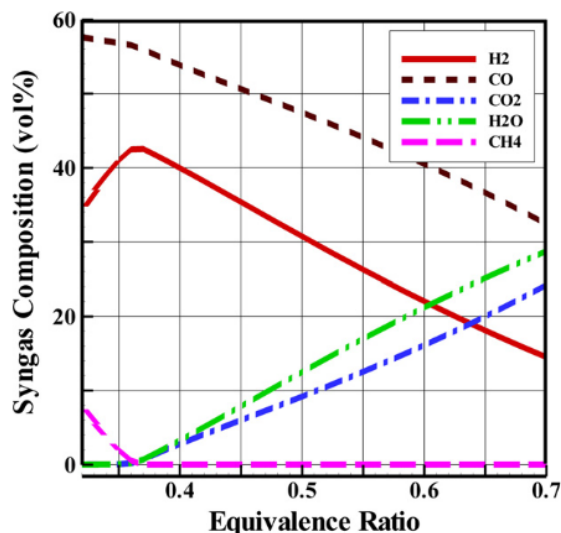

Figure 1 : Effect of the ER on the producer gas composition(from Vaezi et al. [12])

Therefore, monitoring of the ER, i.e the AFR appear of the utmost importance in the gasification process. We have designed and tested two wood fired downdraft biomass gasifier in Burkina Faso [13], [14]. Unfortunately, we were limited by the failure of the five flue gas analyzers we have on hands and even the replacement of the oxygen or carbon monoxide sensors appeared out of reach, because these are relatively costly and not suited for long run usage (maximum 5 minutes recommended by the manufacturers). Therefore, we looked around and found that several authors used Lambda sensors to monitor the excess air and other gases in industrial applications [15], [16], [17], [18]. We also found that the Arduino microcontroller can be used to acquire data from numerous sensors, compute several mathematical functions and display or log these values in an USB drive [19], [20], [21],[22],[23].

Using Lambda sensors and the Arduino microcontroller emerged as very interesting and cost effective replacement solution for monitoring the ER in our biomass gasifiers.

2. Materials and methods

2.1 Experimental setup

Overview of the experimental setup is given on figure 2 below:

Figure 2 : Experimental setup

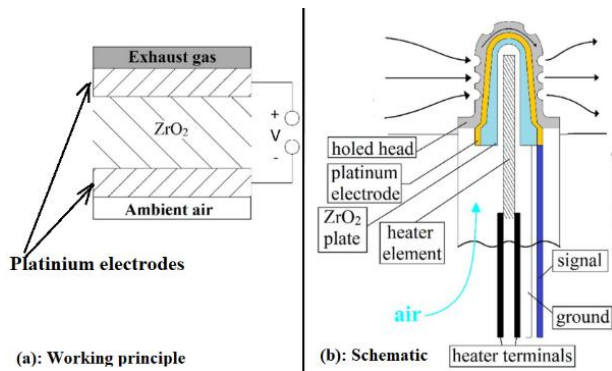
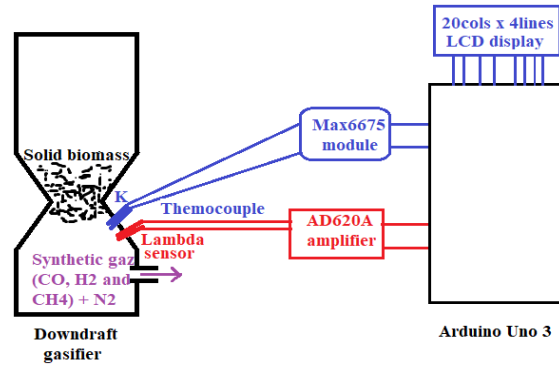

Figure 3 : Working principle and schematic diagram of a Lambda oxygen sensor, from Najjar et al. [24]

Technical specifications of the Arduino Uno 3 development board are given in table 1 below:

Table 1 : Arduino Uno 3 technical specifications

Microcontroller	ATmega328P
Operating Voltage	5V
Input Voltage (recommended)	7-12V
Input Voltage (limit)	6-20V
Digital I/O Pins	14 (of which 6 provide PWM output)
PWM Digital I/O Pins	6
Analog Input Pins	6
DC Current per I/O Pin	20 mA
DC Current for 3.3V Pin	50 mA
Flash Memory	32 KB (ATmega328P) of which 0.5 KB used by bootloader
SRAM	2 KB (ATmega328P)
EEPROM	1 KB (ATmega328P)
Clock Speed	16 MHz
LED_BUILTIN	13
Length	68.6 mm
Width	53.4 mm

Weight	25 g
--------	------

2.2 Methods

2.2.1 Determination of the temperature

A K type **thermocouple** is used along with its amplification and analog to digital converter referenced as Max6675 to acquire the working temperature of the gasifier in °C where the Lambda sensor is plugged in. Conversion in K is made in the Arduino Integrated **Development Environment (IDE)**.

2.2.2 Determination of the oxygen **concentration**:

A zirconium oxide oxygen sensor, as for example the commercial **narrowband** Lambda sensor found in **automotives**, consists of a pair of porous platinum electrodes separated by a layer of the zirconium oxide as illustrated by Najjar et al. [24] on figure 3.a below.

At high temperatures (above 573K) the zirconium ceramic becomes conductive to oxygen ions. The Lambda sensor is made in the way that the sensing side is plugged into the monitored device, while exposition to air is internally assured through the unplugged part of the sensor (figure 3.b above). When exposed to two different levels of oxygen concentration on either side of the cell, for example : one side to **gas** exhaust and another to the **ambient** air, an electro-motive force (emf) voltage is produced. Partial pressures of oxygen in addition to temperature and the emf can therefore be used to determine air/fuel ratio for an exhaust stream from a combustion system when referenced to the known ambient oxygen concentration in air.

The analog signal output from the Lambda sensor computed by Lutero C. de Lima et al. [25] varies from 0 to 80mV around 800°C. At 500°C they found 28mV at 4% and 7.5mV at 15%. Our Arduino board use a 12 bits analog to digital conversion from 0 to 5V. Taking in account that gasification is conducted under sub-**stoichiometric** conditions, we **limit our self** to oxygen content from 3% to 15% at 850°C. Therefore, we need a maximal analog signal amplification gain of $5000\text{mV}/80\text{mV}=62.5$.

Figures figure 4 below depict the AD620 low power μV and mV signal amplifier we used to **amplify** the emf supplied by the Lambda sensor.

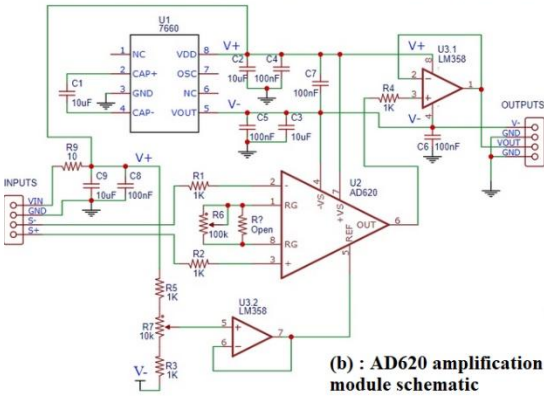
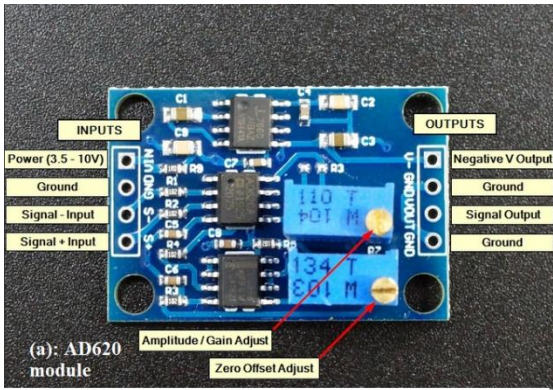

Figure 4 : The AD620 module and schematic

Amplified analog signal from the Lambdasensor was directed to an analog input pin of the Arduino Uno 3 board as illustrated on figure 5 below :

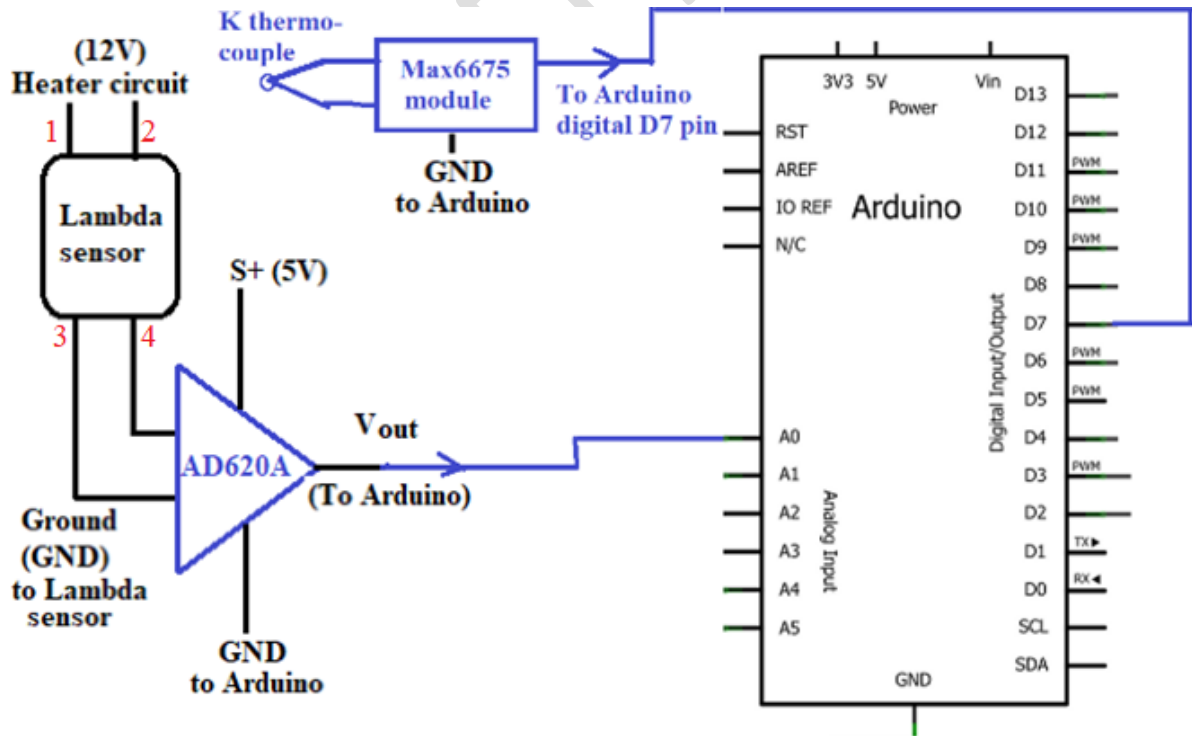

Figure 5: Electrical diagram of the monitoring system

Pins 1 and 2 of the Lamda sensor on figure 5 above are of black color and are those of the heater element. These pins are connected to 12V DC. When heater element is powered, the

DC current read in the order of 0.9A, which give a cold heater resistance of $12V/0.9 = 13.33\Omega$. This heater element resistance increases over time. Heat released by this heater element make the porous ZrO₂ element to become conductive at temperatures above 360°C. But for accurate readings, the manufacturers recommend an operating temperature of 600°C.

Pins 3 and 4 on figure 5 above are the signal pins. Pin 3 of with color is the negative of the emf produced by the Lambda sensor whereas pin 4 is of white color and is the positive of that produced emf on the heater element has a

Oxygen concentration is determined through the Nernst Law:

$$O_2(\%) = 20.96 \exp\left(-\frac{zF}{RT} E\right) \quad (4)$$

20.96 is the volumic concentration of oxygen in clean air,

z is the number of electrons migrating between the sensor electrodes,

F is the Faraday constant,

E is the amplified voltage developed across the sensor terminals,

R is the universal constant of ideal gases,

T is the absolute temperature in the Lambda sensor.

A commercial heated 4 wires Lambda sensor was installed in the reduction zone of a downdraft gasifier. Close to the Lambda sensor was installed a type K thermocouple. A simple, electrical circuit comprising a 5V DC power source in serie with an amperemeter and the heating element of the Lambda sensor was used. An electronic voltmeter was attached in parallel to the heating element. An oscilloscope was also attached to the signal wires of the Lambda sensor as shown in figure 5 below.

Basically, the heating element is driven with an electronic circuit to supervise the electrical resistance of the sensor's heater. That electronic control was not used in this paper and will be implemented through the use of the Pulse Wide Modulation (PWM) technic in another upcoming paper.

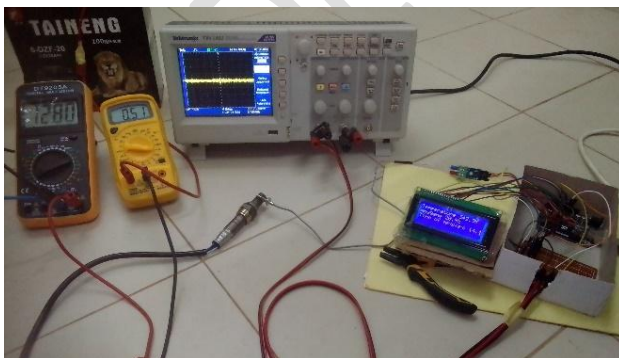

Figure 6 : Heater circuit resistance determination setup

The heater element resistance variation across the time is represented on figure 7 below.

2.2.3 Determination of the AFR

AFR is calculated using equation (3). We must first find the stoichiometric AFR of wood in clean air. Wood composition slightly varies between species, but can be in first approximation represented as $C_6H_{12}O_5$, when wood is supposed not to contain nitrogen or minerals.

The stoichiometric combustion of wood in air containing 21% of oxygen and 79% of nitrogen is the following:

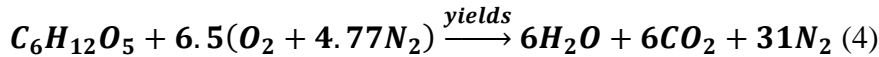

Stoichiometric AFR correspond to 21% of oxygen. Actual AFR, $(AFR)_{act}$ correspond to percent of oxygen given by the lambda sensor according to equation (3). We the derive equation below:

$$(AFR)_{act} = \frac{\text{oxygen}(\%)}{20.96} (AFR)_{sto} \quad (5)$$

3. Results and discussion

3.1 Calibration of the Lambda sensor

The Lambda sensor doesn't require a complicated or costly calibration but the heater resistance of a Lambda sensor widely vary from a supplier to another. We thus first checked the response of the heating element during the application of a continuous electrical power aiming to set the required working temperature of the Lambda sensor to more than 600 °C and to check the Lambda sensor is working as intended. Figure 5 above show the setup for that setup.

The response of the Lambda sensor to a DC power supply is shown on figure 7 below:

Figure 7: Variation of the resistance of the heating element inside the Lambda sensor during the application of an 5V DC power supply.

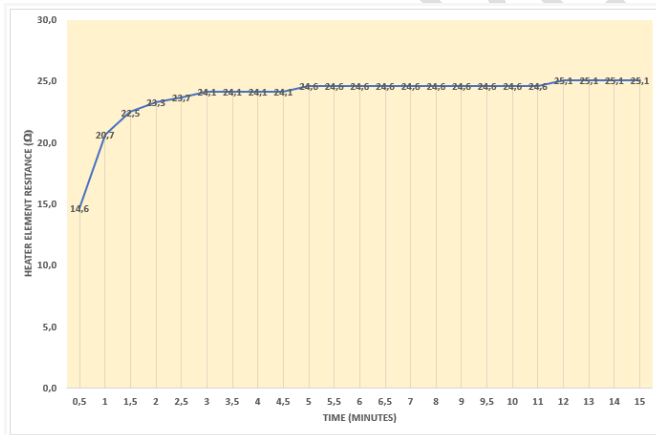

We can see in figure 7 above that the resistance of our Lambda sensor vary from 14.5Ω to 25.1Ω and is stabilized after 5 minutes of heating.

Table 2 : the heater element resistance varies with the temperature over the time as we can see on below

Time(s)	0,5	2	4	6	8	10	12	14	16
R(Ω)	14,6	23,3	24,1	24,6	24,6	24,6	25,1	25,1	25,1

Temperature(°C)	33	35,6	45	55	62	66	69	70	70,1
-----------------	----	------	----	----	----	----	----	----	------

This is because the final temperature of the heater element depends on the power energy it receives and heat radiation in the flue gas. This is because the sensing element is a porous substrate and heat flow from high to lower temperatures. If it happens that flue gas his hotter than the heater element, the last will receive heat from the flue gas. Therefore, temperature of the flue gas also impacts the heater resistance. This is why, the heater element should be managed with an appropriate electronic circuit that aim to maintain the heating element at the correct working temperature.

Gibson *et al.* [26] and Varambanet *al.* [27], using the Current Reversal Mode aimed at improving the accuracy of the measured oxygen content combustion system reported that until 12% of oxygen the correlation is perfect and from 15% up another correlation showed itself perfect, characterizing a transitional behavior of the Lambda sensor at the range from 12 to 15%.

Using the same method and comparing against measurements taken from the reference combustion analyzer (Testo 300 XL) Luterio C. de Lima *et al.* [25], found that the average deviation of the set of measurements was of $\pm 5\%$ and the correlation factor was of 0.97 demonstrating good agreement between the measurement of oxygen concentration at the flue gases and the measurements made by the reference monitor.

In the case of gasification process, we work in sub-stoichiometric conditions. Therefore, we are under 14.7% of stoichiometric combustion of gasoline.

First generation of Lambda sensors are 4 wires sensors, whereas the second generation have 5 wires and are called wideband, because these can measure a wider range of oxygen concentration in flue gaz. Narrowband sensors output an emf of 100mV to 900mV. They don't need extra electronic circuitry other than for the heating element. Wideband Lambda sensors output an emf of 0 to 5V. These sensors must use proprietary modules to work. Better to avoid them in the context of monitoring biomass gasification, because narrowband sensors does the job. We conclude that a narrowband Lambda sensor for measuring oxygen content when monitoring biomass gasification is largely sufficient and accuracy have been supposed based on results in references [15], [25], [26] and [27].

3.2 Computing and displaying AFR

Detailed code is given in appendix. Results obtained are displayed on a 20 columns with 4 lines LCD display as seen in figure bellow 8:

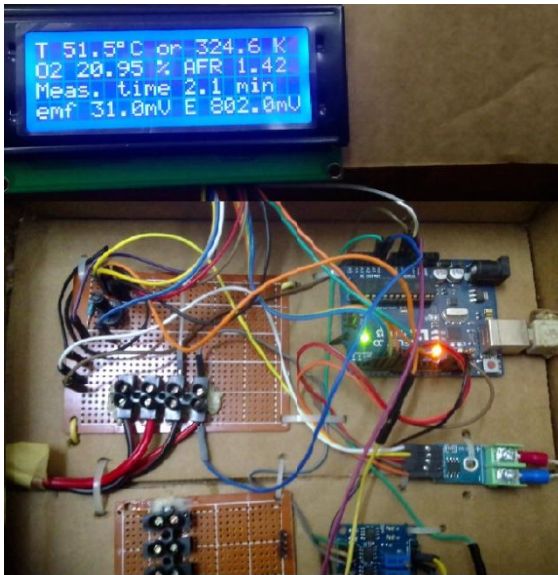

Figure 8 : Finishes prototype with LCD display

In equation 4 above, mass of wood is $m_{\text{wood}} = 164\text{g}$.

Required mass of air for **stoichiometric** combustion is $m_{\text{air}} = 642.07\text{g}$.

Hence the **stoichiometric** AFR is :

$$(\text{AFR})_{\text{sto}} = 642.07/164 = 3.91, \text{ and also}$$

$(\text{AFR})_{\text{act}} = (3.91/20.97) \text{ O}_2(\%)$, **which give:**

$$\text{AFR} = 0.1865 \times \text{O}_2(\%)$$

Reciprocally:

$$\text{O}_2(\%) = \text{AFR}/0.1865$$

According to work of SaharSafirani et al. [28], optimum AFR for wood and woody biomass gasification was comprised between 1.8 and 2. We computed oxygen excess against AFR and obtained figure 9 below :

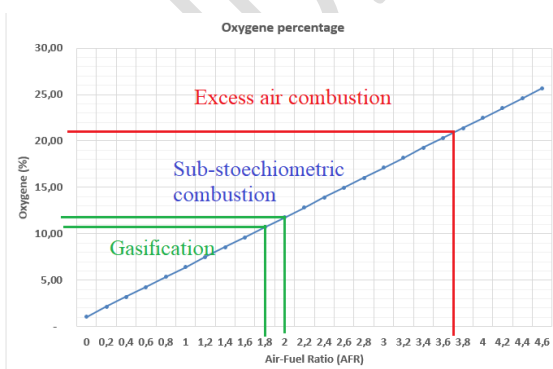

Figure 9 : Oxygene excess as function of AFR

With these results, we can see that monitoring the AFR give us an idea on how well the gasification process is running. As a perspective, we see the possibility of automatically controlling the AFR through a control loop which could give a correction signal through the PWM in order to control the primary air flow of the gasifier thus adjust the AFR.

4. Conclusion

A preliminary heating time of 5 minutes is required before the resistance of the heating element was stabilized. This heating time is necessary to bring the sensing element of the Lambda sensor at temperatures above 360C where the sensing element become conductive and begin to output an emf that is measured in order to calculate oxygen concentration. This work present simple methods for acquiring temperature and oxygen concentration with sensors and an Arduino board. Using the Arduino Integrated Development Environment (IDE), we successfully programmed the Arduino Uno 3 board in C++, measured both the Lambda sensor temperature with a K type thermocouple, the emf developed by the Lambda sensor and the amplified signal E. We calculated O2 concentration, derived the AFR and displayed temperature T (°C and K), O2 (%), AFR, Time of Measure (minutes), emf (mV) and E (mV) on a user friendly 20x4 LCD display. An upcoming paper will address the stabilization of the heating element resistance at a given temperature, when working temperature fluctuate through the use of Pulse Wide Modulation (PWM).

5. REFERENCES

- 1 Sustainable Energy for All, [Burkina Faso]: Rapid assessment and gap analysis, pp. 1-2, https://www.seforall.org/sites/default/files/Burkina_Faso_RAGA_FR_Released.pdf, Accessed 26 septembre 2023. French.
- 2 Joan Nyika, Adeolu Adesoji Adediran, Adeniyi Olayanju, Olanrewaju Seun Adesina and Francis Odikpo Edoziuno, The Potential of Biomass in Africa and the Debate on its Carbon Neutrality, Biotechnological Applications of Biomass, DOI: 10.5772/intechopen.93615, 2020
- 3 Nzihou Jean Fidele, Kouliadiati Jean, Segda B. Gérard. Potential and Feasibility of Solid Municipal Waste Treatment with Gasifiers in a Developing Country: A Review for Burkina Faso British Journal of Applied Science & Technology 4(3): 450-464, 2014 SCIENCE DOMAIN international www.sciencedomain.org
- 4 Wood-Based Biomass Energy Development for Sub-Saharan Africa: Issues and Approaches <https://openknowledge.worldbank.org/entities/publication/9bb75b9a-7102-513b-99be-4895fbff7e2f>; <http://hdl.handle.net/10986/26149>
- 5 VENRO, Rethinking Biomass Energy in Sub-Saharan Africa, https://venro.org/fileadmin/user_upload/Dateien/Daten/Publikationen/Factsheets/2009_Afrika_EU_Bioenergiestudie_englisch.pdf 2009
- 6 Belynda Petrie, Duncan J Macqueen, South African biomass energy: little heeded but much needed, IIED Briefing 4 pages, <https://www.iied.org/sites/default/files/pdfs/migrate/17165IIED.pdf> August 2013

7 Václav Nevrlý, Michal Dostál, Zdeněk Zelinger, Ultra-lean combustion mode in Fundamentals of Low Emission Flameless Combustion and Its Applications, Chapter 2. pages 13-43, <https://doi.org/10.1016/c2020-0-02292-9>, 2022

8 Rui Xiao, Baosheng Jin, Air gasification of polypropylene plastic waste in fluidized bed gasifier, Energy Conversion and Management, Volume 48, Issue 3, March 2007, Pages 778-786, <https://doi.org/10.1016/j.enconman.2006.09.004>, 2007

9 Woranuch Jangsawang, Krongkaew Laohalidanond, Somrat Kerdsuwan, Optimum Equivalence Ratio of Biomass Gasification Process Based on Thermodynamic Equilibrium Model, 2015 International Conference on Alternative Energy in Developing Countries and Emerging Economies, Energy Procedia 79, pp. 520 – 527, 2015

10 S.A. Salaudeen, P. Arku, Animesh Dutta, Chapter 10 - Gasification of Plastic Solid Waste and Competitive Technologies, Fuel, Chemicals, and Sustainability Implications, Plastics Design Library, pp. 269-293, 2019

11 U. ARENA, CHAPTER 17 : Fluidized bed gasification, Fluidized bed technologies for near-zero emission. Combustion and gasification, Volume in woodhead publishing series in energy, pages 765-812
<https://www.sciencedirect.com/science/article/pii/B9780857095411500170>, 2013

12 M. Vaezi, M. Passandideh-Fard, M. Moghiman, M. Charmchi, Gasification of heavy fuel oils: A thermochemical equilibrium approach. Fuel, number 90, pp. 878-885, DOI : <http://dx.doi.org/10.1016/j.fuel.2010.10.011>, 2010

13 Nzihou Jean Fidele, Hamidou Salou, Imbga Kossi, Segda Bila Gerard, Ouattara Frederic, Tientore Hamadou, Electrical Power Generation from Heat Recovered at the Throat of a Downdraft Biomass Gasifier, American Journal of Science, Engineering and Technology, 2023 ; 8(3) : 133-140, <http://www.sciencepublishinggroup.com/j/ajset>
doi: 10.11648/j.ajset.20230803.12, ISSN: 2578-8345 (Print); ISSN: 2578-8353 (Online)

14 Nzihou Jean Fidele, Hamidou Salou, Segda Bila Gerard, Ouattara Frederic and Compaore Hamidou, Effects of a Cyclone Dimensions on Quality of Syngas Produced with a Wood-fired Biomass Gasifier, Journal of Energy Research and Reviews, Article number JENRR.107030, ISSN: 2581-8368, Volume 15, Issue 3, Page 1-14, 2023

15 Antonio S. de Souza Sobrinho, Francisco S. Cavalcante Junior and Lutero C. de Lima, Monitoring Industrial Combustion Through Automotive Oxygen Sensor, International Transaction Journal of Engineering, Management, & Applied Sciences & Technologies : Volume 3 No.2 ISSN 2228-9860, eISSN 1906-9642. Online Available at <http://TuEngr.com/V03/203-211.pdf>, 2012

16 S Aravind, P Ragupathi, D Sathish Kumar, G Vignesh, A Numerical Investigation of Automotive Lambda Sensor to Improve the Life Span of the Sensor using CFD, IOP

Conferences Series: Materials Science and Engineering 923 (2020) 012003, IOP Publishing, DOI:10.1088/1757-899X/923/1/012003, 2020

17 Sleight Halley, Kannan PasupathikovilRamaiyan, Lok-kunTsui, Fernando Garzon, A review of zirconia oxygen, NO_x, and mixed potential gas sensors – History and current trends, *Sensors and Actuators B: Chemical*, Volume 370, 1 November 2022, <https://doi.org/10.1016/j.snb.2022.132363>, 2022

18 A.D. Brailsford, M. Yussouff, E.M. Logothetis, M. Shane, Steady-state model of a zirconia oxygen sensor in a simple gas mixture, *Sensors and Actuators B : Chemical*, Volume 25, Issues 1–3, April 1995, Pages 362-365, 1995

19 A. Y. Nasir, U. I. Bature, N. M. Tahir, A. Y. Babawuro, A. Boniface, A. M. Hassan, Arduino based gas leakage control and temperature monitoring system. *International Journal of Informatics and Communication Technology (IJICT)*, Vol.9, No.3, December 2020, pp. 171-178, ISSN: 2252-8776, DOI: 10.11591/ijict.v9i3.pp171-178.

20Sabr Ahmed, Intelligent Bio-Detector, *Open Journal of Applied Sciences*, 2016, 6, 903-937, DOI: 10.4236/ojapps.2016.613078 December 28, 2016

21 Abubakar Yakub Nasir¹, U. I. Bature², N. M. Tahir³, A. Y. Babawuro⁴, Adoyi Boniface⁵ A. M. Hassan, Arduino based gas leakage control and temperature monitoring system, *International Journal of Informatics and Communication Technology (IJ-ICT)*, Vol.9, No.3, December 2020, pp. 171-178, ISSN : 2252-8776, DOI : 10.11591/ijict.v9i3.pp171-178
Journal homepage: <http://ijict.iaescore.com>, 2020

22 Huan Hui Yan, YusnitaRahayu, Design and Development of Gas Leakage Monitoring System using Arduino and ZigBee, *Proceeding of International Conference on Electrical Engineering, Computer Science and Informatics (EECSI 2014)*, Yogyakarta, Indonesia, 20-21 August 2014

23 L Dewi and Y Somantri, Wireless sensor network on lpg gas leak detection and automatic gas regulator system using Arduino, *IOP Conf. Serie: Material Sciences Engeeniring*, 384 012064, 2018

24 Yousef S.H. Najjar, Abad Alrahman W.H. Almardini, Amro J.A. Sawan, Comparison of performance using wide-band versus narrow-band oxygen sensors in gasoline engines, *Case Studies in Thermal Engineering*, Elsevier Ltd. DOI : <https://doi.org/10.1016/j.csite.2019.100552>, 2019

25Lutero C. de Lima, Humberto A. Carmona, Cesar V. M. da Silva and Francisco S. Cavalcante Junior, Oxygen Excess Control of Industrial Combustion Through the Use of Automotive Lambda Sensor, *International Transaction Journal of Engineering, Management, & Applied Sciences & Technologies*, Volume 2 No. 3. ISSN 2228-9860. eISSN 1906-9642. Online Available at <http://TuEngr.com/V02/365-373.pdf>, 2011

26Gibson, R.W., R.V. Kumar and D.J. Fray. (1999). Novel sensors for monitoring high oxygen concentrations. *Solid State Ionics*, 121, 43-50, 1999

27Varamban, S.V., R. Ganesan and G. Periaswami. (2005). Simultaneous measurement of emf and short circuit current for a potentiometric sensor using perturbation technique, *Sensors and Actuators B*, 104, 94-102, 2005

28 International Journal of Applied Power Engineering (IJAPE)
Vol. 10, No. 1, March 2021, pp. 80~88
ISSN: 2252-8792, DOI: 10.11591/ijape.v10.i1.pp80-88

Appendix A : Arduino code

```
#include<LiquidCrystal.h>
#include"max6675.h"
#include<Wire.h>
#include<U8g2lib.h>
LiquidCrystal lcd(12,8,5,4,3,2);
int OxyPin = A0; //Oxygen pin is A0
int thermoDO = 7; //Digital pin D7
int thermoCS = 13; //CS pin is 13
int thermoCLK = 6; //Ok
float temperature = 0.0; //Define temperature
char disp;
MAX6675 thermocouple(thermoCLK, thermoCS, thermoDO);
int vccPin = 3;
int gndPin = 2;
float oxyPercent; //Oxygen
float eO2=0.0; //Analog voltage developed by the lambda sensor
float To2=600.0; //Working temperature of the lambda sensor
#define F96485.34 //Define the Faraday constant
#define R8.314 // Define the constant gases
#define O2Air20.96 //Define Oxygen concentration in clean air
#define T0273.2 // Define temperature in K
#define z1.6*pow(10,-19) //Electronic charge
float Tom = 0.0; //Time of measure
void setup(){
  Serial.begin(9600);
  // Max 6675 setup
  pinMode(vccPin, OUTPUT); digitalWrite(vccPin, HIGH);
  pinMode(gndPin, OUTPUT); digitalWrite(gndPin, LOW);
  //End setup for Max 6675
  //Setup LCD display
  lcd.begin(20,4); //LCD's number of columns and rows:
  lcd.clear();
  lcd.print("Powering on. Please wait...");
  delay(1500); //Give 1s to read
  lcd.clear();
  lcd.print("Lambda sensor calibration in progress");
  delay(1500); //Give reader 1.5 second to read the display
}
void loop()
{
```



```

temperature = thermocouple.readCelsius()+273.15; //Temperature is converted in
K
//Oxygen with Lambda sensor
eO2 = analogRead(OxyPin);
    To2=temperature;
        oxyPercent = 205*(O2Air*(exp((-z*F*eO2)/(R*To2)))/1023.0*5.0));
//Temperature is converted in K
// Calculate Oxygen concentration according to equation derived from the
Nerst Law
//We now display T and O2
lcd.clear(); // Clear LCD to avoid weird characters display
lcd.setCursor(0,0);
lcd.print("Temperature ");
lcd.print(temperature,1); //Display Reactor temperature with 1 decimal
lcd.print("K ");
//Display O2 in %
    lcd.setCursor(0,1);
    lcd.print("Oxygene ");
    lcd.print(oxyPercent, 1); // Print Oxygen content on LCD
    lcd.print("%");
//Display what is the time elapsed?
lcd.setCursor(0,2);
lcd.print("Time of measure ");
unsigned long currentMillis = millis();
Tom = ((currentMillis/1000)/60.0);
lcd.print(Tom,1);
lcd.print("mn");
// End calculating and displaying other parameters
delay(intervalHigh);
}; // End loop

```

UNDER PPL