

# LEARNING MEDIA DEVELOPMENT PHOTOVOLTAIC (PV) INTEGRATION DATA COMMUNICATION SCALABLE MODEL WITH INTERNET OF THINGS (IoT)-ASSISTED MONITORING

## ABSTRACT

The aim of this research is to create educational materials for Data Communication by combining photovoltaic (PV) technology with a scalable model and monitoring through the Internet of Things (IoT). The research assessed the feasibility of implementing photovoltaic integration and a scalable model to determine the energy usage level. Additionally, it developed a learning aid product (media trainer) that is valid, practical, and effective for learning, using IoT-assisted monitoring for data communication.

The focus of this study is on students who are using Network and Data Communication studying in the Department of Electrical and Computer Engineering at Gorontalo State University. The research will utilize media trainers as educational tools for learning purposes. The research methodology employed in this study involves the stages and steps outlined in the ADDIE development model. The validation of the product's quality feasibility has been conducted by a team of expert validators through the use of focus group discussions (FGDs). Using a methodology that involves analyzing data using descriptive statistics. The results indicated that the trainer media was deemed highly valid by a team of expert assessors, with an average total score of 3.82. Additionally, the formative assessment of the trainer media users yielded a score of 3.64, which was interpreted as highly practical. The results effectively demonstrated the difference in learning outcomes before and after using the product.

**Keywords:** *Media Development, Photovoltaic, Data Communication, IoT.*

## INTRODUCTION

Education is a fundamental indicator of a nation's advancement and well-being. Education has a crucial role in human life, enabling individuals to acquire knowledge and develop their character, which in turn facilitates their interactions with others. Education equips individuals with the necessary skills and knowledge to effectively engage with and adapt to societal changes [1]. The advancement of Science and Technology (IPTEK) across many domains need highly skilled Human Resources (HR). The Indonesian government aims to cultivate high-caliber human resources through education [2]. High-quality education fosters the development of intelligent pupils who possess the skills and knowledge necessary to thrive in the era of globalization [3]. The field of education is significantly impacted by science and technology [4]. Hence, education plays a crucial strategic role in the advancement of a nation, particularly in the case of Indonesia. This aligns with the primary aim of education, which is to enhance the caliber of human capital in order to generate high-quality individuals through excellent education [2]. The execution of education is significantly impacted by the execution of the learning process[3], however, it necessitates the provision of appropriate facilities and infrastructure that are pertinent to the assimilation of technology in the present industrial period. 4.0.

Essentially, teaching and learning can be described as a process of communication. Communication is the process of exchanging messages or information between two or more individuals. To ensure the effective transmission of messages or information, it is necessary to utilize appropriate media [5].

The current technological advancements have a significant influence on human existence, particularly in the realm of educational media development (Setiawan, (2021). To identify the issues in learning, a process of conducting direct observation of the learning process, as well as evaluating the facilities and infrastructure that facilitate learning, is undertaken.

By analyzing the observations of lecturers and students, it was found that the Department of Electrical and Computer Engineering at the Faculty of Engineering, State University of Gorontalo, needs real data sources to enhance students' understanding of data communication learning. These data sources should align with the observed data sources and meet the strategic conditions of learning activities. Based on the

survey results on media requirements and the utilization of alternative media forms, it was found that 88.88% of surveyed lecturers who serve as course instructors expressed the need for media as a learning tool. Conversely, 11.11% of lecturers reported not requiring media. Similarly, when analyzing student needs, 93.33% of students expressed the need for media, while 6.6% reported not needing it. In terms of practical modules and media, 100% of respondents in this category indicated a requirement for media. The researchers' observations of computer network and data communication courses have not yet yielded any media learning aids to serve as a reference for the development of media needs. Higher education is an institution that focuses on providing education and conducting research to address societal issues, such as energy usage and the application of Internet of Things (IoT) technology. However, in order to produce skilled individuals, a learning strategy is necessary in the field of education. Aligned with the mission of the Department of Electrical and Computer Engineering, Faculty of Engineering UNG, the goal is as follows:

Vision: "To become an excellent study program in the fields of energy, electronic signals, and information based on a culture of innovation in Southeast Asia in 2035".

However, the observations indicate that the attainment of learning goals is hindered by the limited availability of facilities, traditional verbal forms of learning, students' disinterest and lack of engagement in the learning process. Additionally, students only rely on outdated instructional methods that are no longer applicable in the present era. In order to enhance students' competence and critical thinking skills in addressing societal challenges, it is imperative to develop learning media that are both feasible and effective. These media should focus on energy problems, conservation, and the utilization of natural resources as alternative solutions. This approach aligns with the study program's vision and addresses the relevant needs of the learners.

The issue of energy is of utmost importance in a nation, as it is a crucial factor that significantly influences both progress and human existence. The accessibility of energy is the primary concern in meeting and evaluating the level of societal well-being.

[7]state that the world energy situation and its implementation strategies have witnessed a significant rise in energy efficiency and the use of renewable sources over a span of 30 years. Additionally, (Baena *et al.*, 2020) emphasize the substantial contribution of renewable sources. Understanding these limitations will enable the development of a comprehensive framework for energy sector planning, as well as the assessment and integration of future solar projects into the power system. The study conducted by Ardiyanto *et al.*, (2020) the Indonesian government, specifically the Ministry of Energy and Mineral Resources (MEMR), is actively enhancing the adoption of renewable energy sources in the country.

Renewable energy refers to energy derived from natural sources that can be replenished. When correctly managed, these resources are sustainable and will not be depleted. Solar power plants (PLTS) are a promising example of new and renewable energy generation systems (EBT) for the future.

The project aims to build learning media for higher education institutions that would enable the production of human resources with a comprehensive understanding of energy utilization and conservation, based on the findings from these observations. According to various studies, the development of solar photovoltaic (PLTS) solar panels is crucial due to the increasing population and the growing demand for electrical equipment. This leads to a higher demand for electricity, resulting in increased electricity costs. For instance, in a residential house with four out of five occupants using electrical devices such as mobile phones, laptops, flashlights, electric bikes, and chargers for lighting, the reliance on electricity provided by PLN significantly impacts the electricity expenses for the community. This research was undertaken to develop a solar Photovoltaic (solar panels) energy system as an abundant and ecologically benign source of energy. The aim is to utilize this system to mitigate the rising electricity expenses.

To meet requirements related to the development and implementation of Photovoltaic systems (solar power plants) or solar cells. In order to address these issues, it is imperative to engage human resources who possess expertise in the matter. This necessitates the involvement of educational institutions, including vocational schools and universities, where students can be trained as valuable human resources. To equip them with the necessary knowledge about photovoltaic systems and their impact, a method utilizing a model and learning media tools should be implemented. This will enable them to effectively assist in resolving the challenges associated with residential electricity consumption in the community. However, colleges also require adequate facilities and infrastructure to support this endeavor. This research is grounded on a reference to design a learning media device that utilizes societal challenges as a foundation for generating solutions in higher education institutions. By utilizing media, students are provided with the opportunity to observe the photovoltaic circuit application system and its

components, enabling them to gain a comprehensive understanding of the system and the utilization of residential electrical energy. Through simulations in the media, students can directly observe data readings obtained through serial communication, which provides information about energy usage. The learning aids are designed as media in the form of a trainer board with a circuit layout installation. This board represents the use of residential electrical energy and is equipped with data flow monitoring using the IoT system. It serves as a platform for learning about data communication and integrates the photovoltaic system as a PLTS system. The board also includes simulations. This technology has the potential to be transferred to the industry 4.0 in the IoT subsection.

Current learning media facilities according to the results of observations in general educational media are only static and conventional in nature whose use is only limited to practical modules so that further development is needed with a dynamic system with direct and online use with the application of IoT Technology for monitoring results as an implementation in data communication learning which can be actually learned by students to be able to think critically and not verbally and boring so that learning objectives can be achieved, to be able to produce the development of learning media that is feasible, valid, practical and effective for learning data communication in the world of education, which requires students to develop and maximize the potential of available energy sources, as one of the triggers so that students have an interest in energy use and provide solutions to classic community problems and increase competence and understanding of the process of visualizing data communication in real measurements and the application of the latest technology.

## **METHOD**

The research employed the R&D technique, specifically integrating scalable Photovoltaic models. These models were adjusted based on priority scale demands such as lighting, equipment chargers, and minor power needs. The aim was to combine research and development efforts. The research and development (R&D) of the ADDIE model aims to enhance and broaden existing knowledge. Development research is typically employed to create or manufacture a product. The analysis employed is descriptive statistics.

The ADDIE model is a framework used for Research and Development (R&D) purposes. The ADDIE development research model is a structured approach that encompasses five distinct stages: Analysis, Design, Development/Production, Implementation, and Evaluation. The ADDIE model was established by Dick and Carey in 1996.

The utilized equipment and materials consist of scalable solar cell panels, namely photovoltaic (PV) panels, which can be adjusted in size to accommodate various field conditions and types. The required components for the system include polycrystalline solar panels, batteries, a solar charge controller (SCC), a DC to AC inverter (12V DC to 220V AC), microcontrollers such as NODEMCU esp 8266, Wemos D1 mini, and Arduino R3, a power supply, voltage and current sensors, an AC sensor (PZEM-004T), an internet connection for IoT transmission, a Connector, and necessary cables and jumpers. The user mentions the utilization of many technologies and applications, including photovoltaic support, electronic components, the Arduino IDE application software, and the Internet of Things (IoT) platform called Cayenne DLS.

The research was conducted at the Campus of Universitas Negeri Gorontalo, namely at the Faculty of Engineering, Electrical and Computer Department, located in Gorontalo Province.

The research data is collected through the utilization of surveys and questionnaires. The initial survey approach is employed for observation in order to get the necessary preliminary data for the analysis of requirements in product creation.

## **RESULT AND DISCUSSION**

In this section, it discusses the description of the results of learning media development research which outlines the identification of the following systematic steps:

### **Design Concept of Learning Media Development of Photovoltaic (pv) Integration Data Communication Scalable Monitoring Model Assisted by IoT.**

The design concept for learning media development adheres to a systematic approach, employing the research and development (R&D) methodology and various stages of development. During the research and development phase, the primary objective is to analyze the recognized opportunities and significant obstacles in order to devise efficient solutions. In light of the research context, the first phase of this study entails carrying out research and development procedures to examine the prerequisites for designing a

scalable learning medium for data communication in photovoltaic integration. This procedure is facilitated by the Internet of Things (IoT) and comprises the subsequent stages: a) Conducting a needs analysis, b) Creating a profile of the Electrical Engineering Department at the Faculty of Engineering, Universitas Negeri Gorontalo, c) Analyzing the needs of the lecturers, d) Analyzing the needs of the students, e) Designing and developing media, and designing the layout form for media trainers.

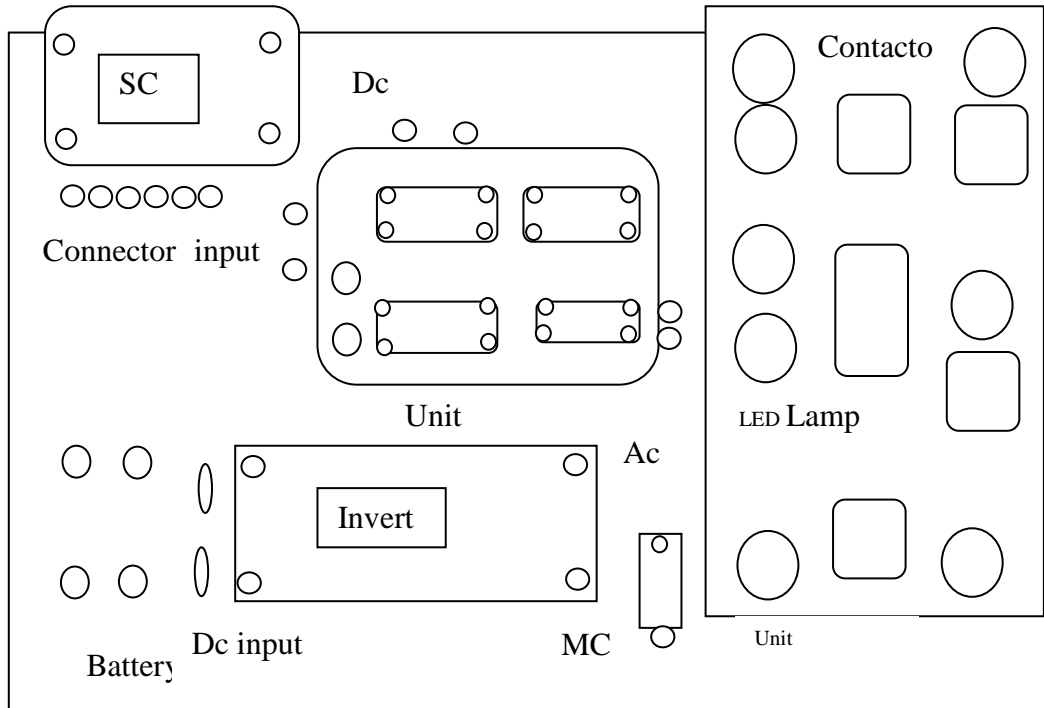
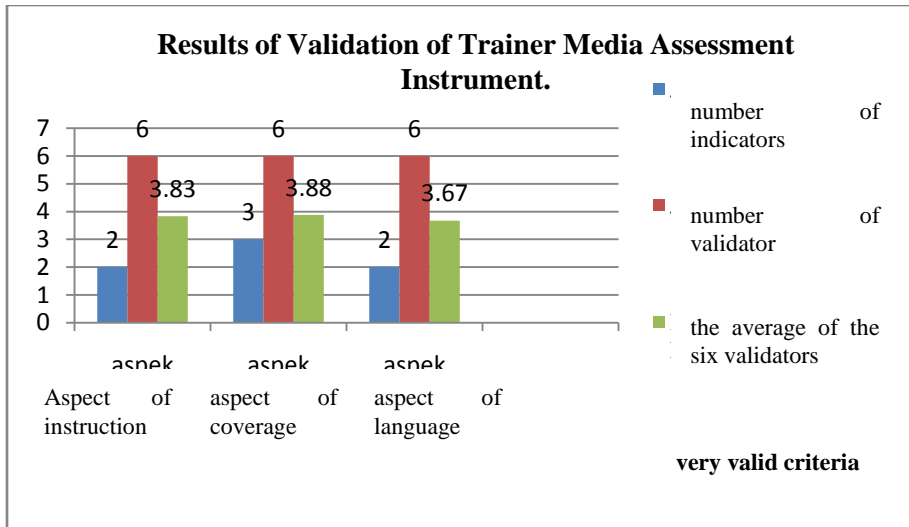

Figure 1. Media Trainer Design layout form



(a) Media Trainer Products (b) Practice Guidelines  
Figure 2. Product Shape of Integrated Media Development Results

**Learning Media Development Results of photovoltaic (PV) integration data communication Scalable model assisted by IoT valid Used for learning**



**Figure 3. Graph of the Validation Results of the Trainer Media Assessment Instrument**

The validation of the trainer media assessment instrument was conducted by six validators. The results showed that the instructions aspect received an average value of 3.83 on a Likert scale of four, which is interpreted as "Very valid". The coverage aspect received an average value of 3.88, also considered "very valid". Similarly, the language aspect received an average value of 3.67, meeting the criteria for "very valid". Overall, the instrument is deemed "very valid" based on these criteria. Therefore, the instrument is suitable for collecting research data. Moreover, the outcomes of the instrument assessment were utilized for data collection.

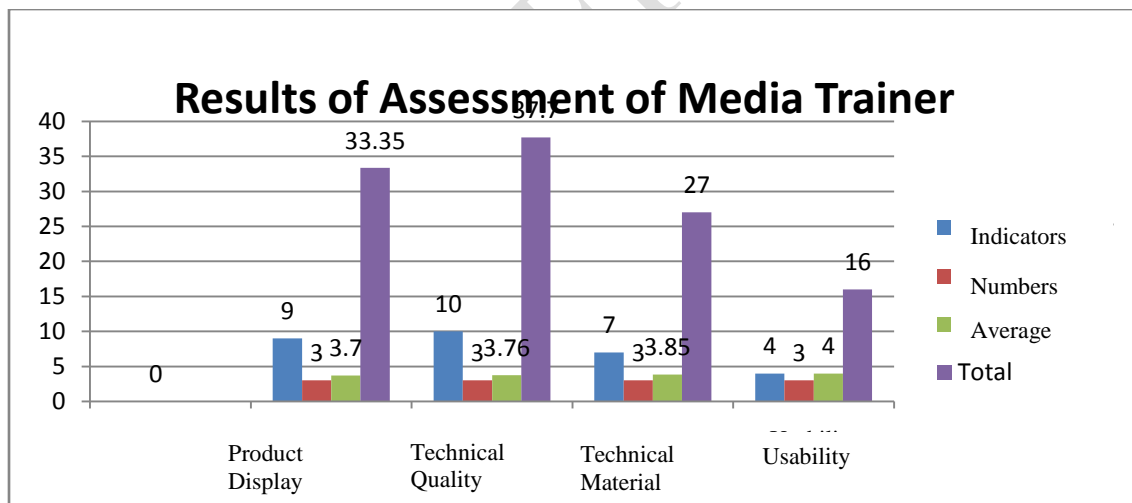

**Figure 4. Graph of the Assessment Results of Media Trainers**

The figure 4 displays the assessment results of the trainer media by experts. The aspect of product appearance received an average value of 3.7, the technical quality aspect received an average value of 3.76, the material quality aspect received an average value of 3.85, and the usability aspect received a value of 4.00. The assessment was conducted using a Likert scale with a scale interpretation of four. All these aspects were categorized as "very good/valid," indicating that the media is suitable for use as a data communication learning tool.

**Learning Media Development Results of Data Communication Integration Photovoltaic scalable model with IoT-assisted monitoring Practically Used for Learning.**

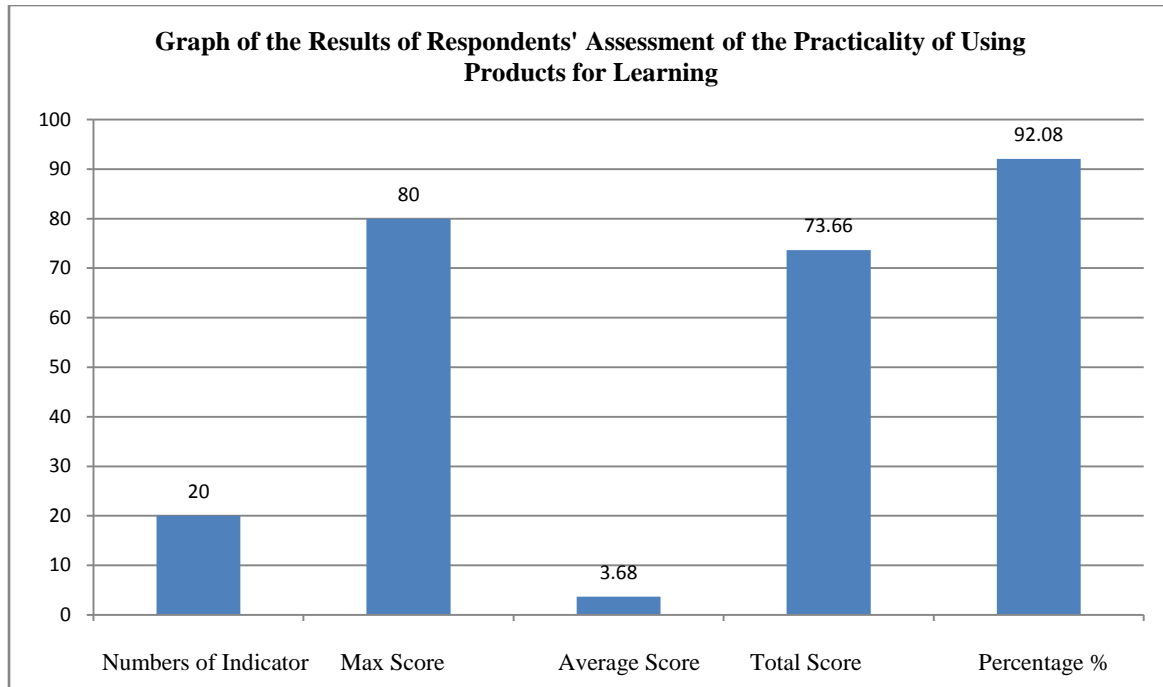

**Figure 5: Graph of the Results of Respondents' Assessment of the Practicality of Using Products for Learning in One-on-One Trials.**

The figure 5 shows that the respondents rated the practicality of using learning media development products for one-on-one scale trials. The average score was 3.68, which corresponds to a percentage of 92.08%. The assessment was conducted using a Likert scale with four categories, and the results fell into the "very practical" category. Therefore, the development of these products is considered suitable for use as a learning aid. Feedback and recommendations for enhancement are reviewed, and once the modification is completed, it is carried over to the subsequent experiment in the small group setting.

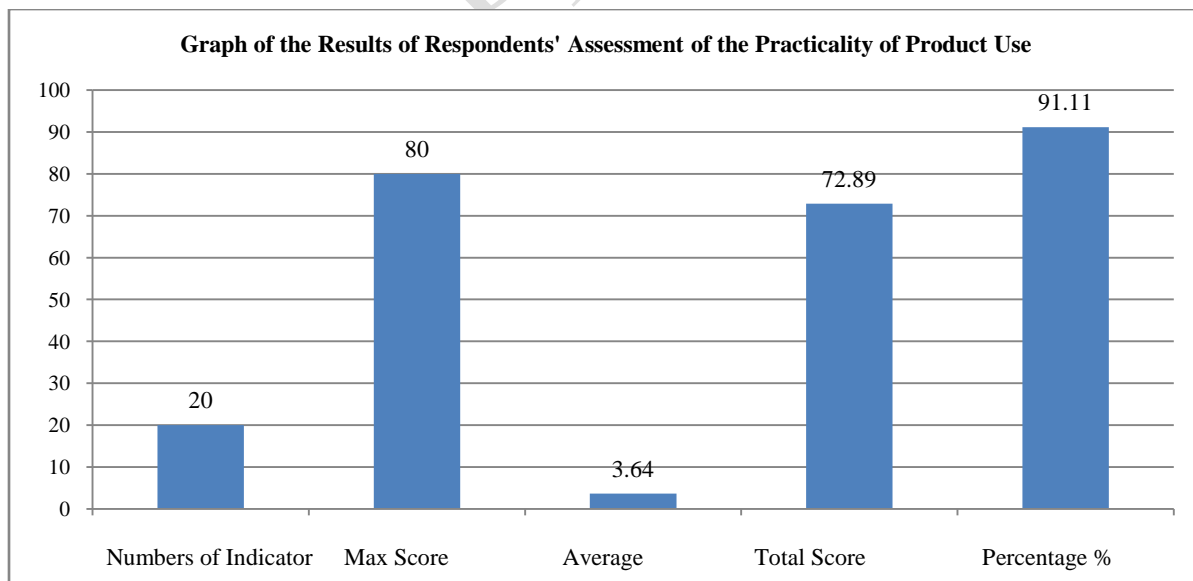

**Figure 6: Graph of the Results of Respondents' Assessment of the Practicality of Using Products for Learning in Small Group Trials.**

The figure 6 displays the results of the small group trial, which assessed the practicality of the learning aid trainer. The respondents' average score was 3.64, with a total score of 72.89. These results were measured using a Likert scale with four categories. The interpretation of the results falls into the "very practical" category. Therefore, the media development of this learning aid trainer is suitable for data communication learning.

### **Learning Media Development Results of Photovoltaic Integration Data Communication Scalable Model Assisted by IoT, Effective for use in learning.**

The effectiveness of goods arising from the construction of learning assistance trainer media is assessed by T-test analysis. This involves administering pretests and posttests to users and carrying out field tests.

**Table 1. T test analysis results using paired sample test**

|                            |
|----------------------------|
| <b>Paired Samples Test</b> |
| Sig. (2-tailed)            |
| .000                       |

The table presents the analysis findings using the T test with paired samples. The choice regarding the T test results is based on the probability value or Asymp.sig in the table, where sig (2 tailed) = 0.000. The decision is made according to the following criteria:

- 1) If the asymptotic significance or probability is more than 0.05, then H<sub>0</sub> is accepted.
- 2) If the asymptotic significance or probability is less than 0.05, then the null hypothesis (H<sub>a</sub>) is rejected.

The T Table value of the distribution is 2.045. Based on the significance level (Asymp.sig) of 0.000, the obtained results indicate that the significance value is smaller than the predetermined value of  $\alpha = 0.05$  ( $0.000 < 0.05$ ). Therefore, the conclusion is that H<sub>a</sub> is accepted, which means that there is a difference in student learning outcomes when using trainer media development products in learning, after treatment using trainer media products (tools),gaining expertise in the domain of data communication.

### **CONCLUSION**

The development of scalable model photovoltaic (pv) integration data communication learning media with IoT-assisted monitoring, planned with a design concept based on needs analysis, profile of the Department of Electrical and Computer Engineering, Faculty of Engineering UNG, analysis of lecturer needs, analysis of student needs, with the form of validity assessment results of the instructions aspect with an average value of 3. 83, the coverage aspect with an average value of 3.88, the language aspect with an average value of 3.67 so that the overall instrument with the criteria is "very valid", the results of the assessment of the results on the aspect of the product display with an average value of 3.7, the technical quality aspect with an average value of 3.76, the material quality aspect with an average value of 3. 85, and the Usability aspect scored 4.00, with the results: very good / valid "then the one-on-one / individual scale trial obtained an average score of 3.68 with a percentage of 92.08%, measured using a Likerts scale on a scale of four with criteria in the category "very practical, and based on effectiveness carried out with the T test obtained based on the significance of Asymp. sig (sig (2 tailed) = 0.000) from the criteria obtained results with the conclusion that the sig value = 0.000 then the significance value is smaller than the predetermined value of  $\alpha = 0.05$ , ( $0.000 < 0.05$ ) the result is H<sub>a</sub> accepted means there is a difference in student learning outcomes by using trainer media development products in learning.

In order to advance the platform, it is necessary to utilize a range of different variables and component devices that possess exceptional quality. These devices should be replicated, and it is also important to ensure that wifi installation is accessible at the site where the platform will be employed.

### **REFERENCES**

1. Mustika IA. DEVELOPMENT OF DIGITAL ENGINEERING TRAINERS AS LEARNING MEDIA IN DIGITAL ENGINEERING COURSES BASED ON INDUSTRIAL APPLICATIONS.
2. Artanto.H. IOT Trainer Based on ESP8266 as a Learning Media for Data Communication and Interface Subjects in the UNY Electrical Engineering Education Study Program. Electronics Engineering Study Program, Faculty of Engineering, Yogyakarta State University; 2018.

3. IMJ's son, Wiyasa IKN. Increasing Students' Enthusiasm in Science Learning Through Interactive Multimedia Oriented to a Contextual Approach to Energy Source Material for Class IV Elementary School. 2021;8(1).
4. Kholifah U. Study of the Application of Blended Project Based Learning in Improving Communication and Collaboration Skills in Data Communication and Computer Networks Courses. 2019;04.
5. Sugihartini N, Yudiana K. ADDIE AS A DEVELOPMENT MODEL FOR EDUCATIVE INSTRUCTIONAL MEDIA (MIE) IN CURRICULUM AND TEACHING SUBJECTS. J Technological and Vocational Educator [Internet]. 2018 Aug 11 [cited 2023 Jan 20];15(2). Available from: <https://ejournal.undiksha.ac.id/index.php/JPTK/article/view/14892>
6. Setiawan H. IMPLEMENTATION OF PLTS AS A REPLACEMENT OF THE MAIN 1300VA HOUSEHOLD ELECTRICITY SOURCE. :14.
7. Alfonso-Solar D, Vargas-Salgado C, Sánchez-Díaz C, Hurtado-Pérez E. Small-Scale Hybrid Photovoltaic-Biomass Systems Feasibility Analysis for Higher Education Buildings. Sustainability. 2020 Nov 9;12(21):9300.
8. Baena F, Muñoz-Rodríguez FJ, Gómez Vidal P, Almonacid G. A New Approach to Estimate from Monitored Demand Data the Limit of the Coverage of Electricity Demand through Photovoltaics in Large Electricity Grids. Sensors. 2020 Aug 6;20(16):4390.
9. Ardiyanto Y, Chamim ANN, Wiyagi RO. Implementation of Solar Cell Based Public Street Lighting as a Learning and Promotion Media. :7.