

# Design of control system of oil collection device

---

## ABSTRACT

The South-to-North Water Diversion project is a large water conservancy project implemented by the Chinese government to solve the water shortage problem in North China, but the oil slick pollution is an important problem. Aiming at the problem of oil slick pollution, a control system of oil slick collection device is designed in this paper. First of all, the design idea of intercepting first, then collecting, and then separating was determined, and the software was programmed. The simulation of Proteus software showed that the control program was stable and reliable, the pressurizing device could realize manual and automatic control respectively, and the oil-water separation device could realize the control of the three valves.

*Keywords: South-to-north water diversion; Proteus; Simulation; Oil-water separation.*

## 1. INTRODUCTION

The South-to-North Water Diversion Project is the world's largest inter-basin water transfer project, which is a major strategic infrastructure to alleviate the shortage of water resources in the northern region of China, realize the rational allocation of water resources, guarantee the sustainable economic and social development, and build a moderately prosperous society in an all-round way[1]. However, due to the huge rivers, reservoirs and other waters involved in the project, the South-to-North Water Transfer Project also faces many challenges in environmental protection and water pollution control during the construction process. Among them, oil slick pollution is an important problem facing the South-to-North Water Diversion Project. In this paper, the control system of oil slick collection device is designed[2].

## 2. OVERALL DESIGN OF CONTROL SYSTEM FOR OIL SLICK COLLECTION DEVICE ON WATER

### 2.1 WORKFLOW INTRODUCTION

Through the study, the basic working idea of the floating oil collection device on the water was determined, as shown in Fig. 1, it was determined that the first intercepted by the interceptor plate, and then extracted by the collection device, and then through the pressurized device to provide power, so that the oil-water mixture into the centrifugal oil-water separation device can be high-speed rotation so as to produce a large centrifugal force, so that the oil-water mixture is separated[3].

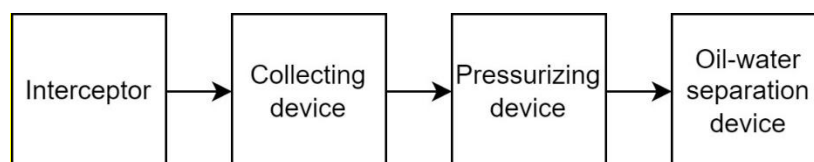

**Fig.1 Overall design idea diagram**

## 2.2 COLLECTION DEVICE DESIGN PROGRAM

The design is shown in Figure 2, the temperature sensor to detect the temperature, the detected temperature will be output to the LCD1602 screen to display the current temperature, before the limit temperature is set, the system will fill the current temperature to the limit temperature, through the key to set the limit temperature, when the current temperature is greater than the set maximum temperature, then the motor will stop rotating, i.e., the pumping pump stops working. In addition, the speed of the motor, i.e. the power of the pump, can be adjusted by pressing the key[4]. The LCD1602 displays the motor speed, the current temperature and the set limit temperature by key control.

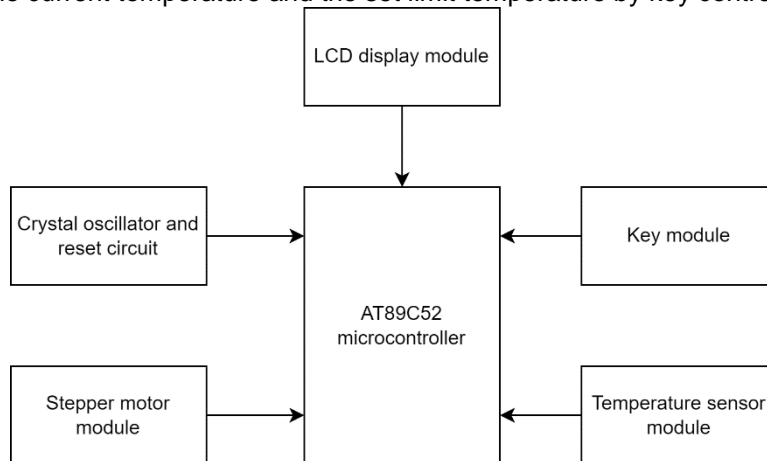

**Fig. 2 Collecting device control system structure block diagram**

## 2.3 PRESSURIZATION DEVICE DESIGN SCHEME

Design program shown in Figure 3, the water level detection module detects the height of the water level, and then the water level height will be output to the A/D conversion module, ADC0832 conversion module will be converted to the calculation of the voltage value for the height of the water level and output, and the output of the height of the water level will be displayed in the LCD1602 screen[5]. In automatic mode, the AT89C52 microcontroller will compare the current height with the set height, if the detected height is greater than the set height, the motor rotates, i.e., the booster pump works, the relay opens, i.e., the water valve opens. If the specified height is not reached, the motor and relay remain closed. In manual mode, the switch of motor and relay is no longer limited by the height of the water level, and the switch of motor and relay is controlled by the key[6]. The motor and relay can be switched to manual or automatic mode by pressing the key. In addition, through the key, you can control the LCD1602 screen display content, including the test interface, water level height interface, manual and automatic switching interface, manual mode interface. In the manual mode interface, it will display the water level height, whether it is currently in the manual state, motor speed and relay closure status[7].

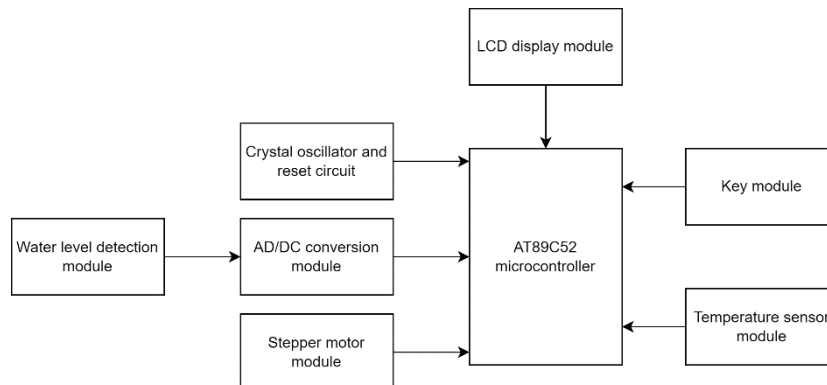

**Fig. 3 Block diagram of pressurized unit control system**

## 2.4 DESIGN SCHEME OF OIL-WATER SEPARATION DEVICE

The design scheme is shown in Fig. 4. The three keys of the key module control the switching of three relays respectively.

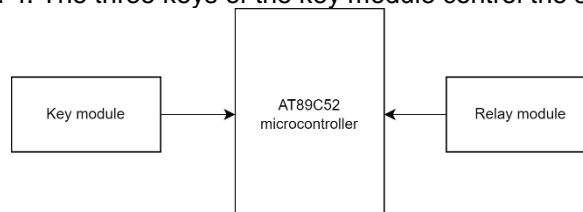
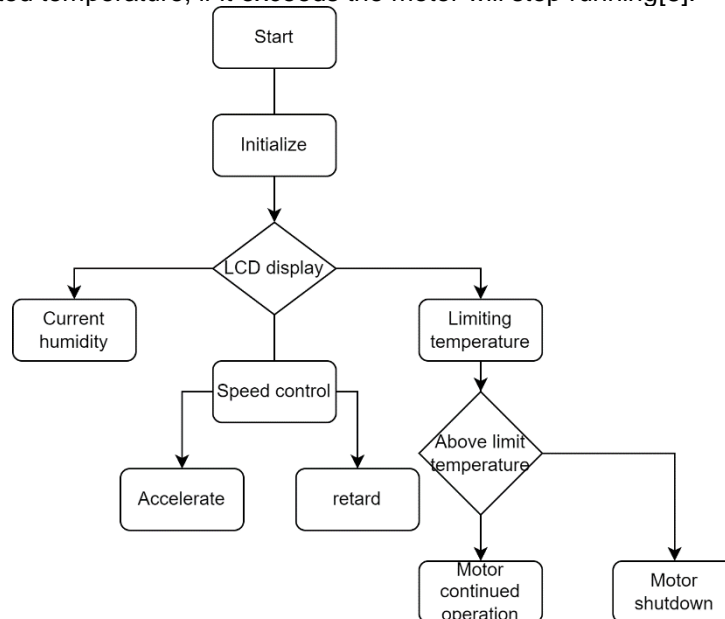

**Fig. 4 Block diagram of the structure of the control system of the oil-water separation device**

### 3. SOFTWARE PROGRAM DESIGN PROGRAM

#### 3.1 COLLECTION DEVICE SOFTWARE PROGRAM DESIGN SCHEME

Collection device program design scheme shown in Figure 5. First of all, the system needs to be initialized, in the speed control interface can be achieved through the key to accelerate and decelerate the motor control, the temperature display interface will display the current temperature, the limited temperature interface will determine whether the current temperature exceeds the limited temperature, if it exceeds the motor will stop running[8].



**Fig. 5 Flowchart of the collection device program**

#### 3.2 PRESSURIZATION DEVICE SOFTWARE PROGRAM DESIGN SCHEME

Pressurization device program design scheme shown in Figure 6. First of all, the system is initialized, in the automatic control will determine whether the water level exceeds 150cm, if it exceeds, the motor will run, the relay will open, that is, the outlet valve will open, if it does not exceed the two will remain closed. In manual control, through the key will control the motor speed, motor switch and relay switch[9].

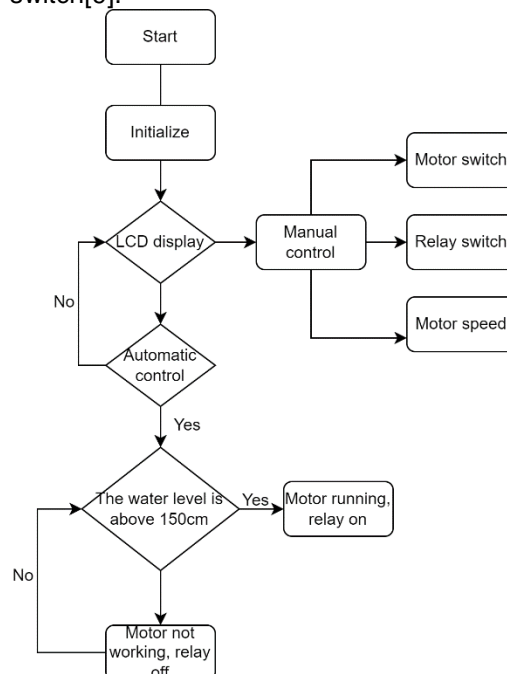

**Fig. 6 Flowchart of the pressurization device program**

#### 3.3 OIL-WATER SEPARATION DEVICE SOFTWARE PROGRAM DESIGN SCHEME

The program design scheme of the oil-water separation device is shown in Figure 7. First of all, the system is initialized, which can be used to control the switching of three relays, i.e. three valves, by three buttons respectively.

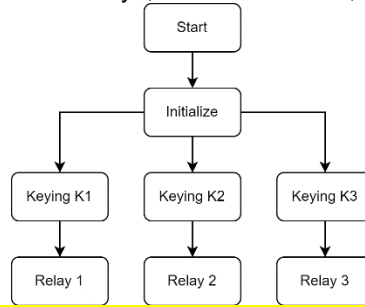
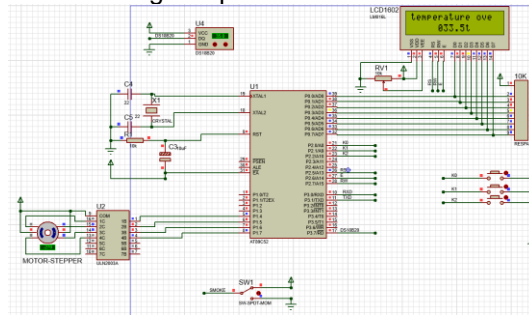

**Fig. 7 Flow chart of the program of the oil-water separation device**

## 4. RESULTS

### 4.1 COLLECTION DEVICE SIMULATION CIRCUIT DESIGN

The collection device using Proteus software simulation model shown in Figure 8, mainly consists of the main control chip and the minimum system, stepper motor module, temperature sensor module, LCD display module, key module. Enter the program into the simulation circuit to meet the design requirements.



**Fig. 8 Simulation model diagram of the collection device control system**

As shown in Fig. 9, the minimum system of AT89C52 is the core and foundation of the whole microcontroller, which consists of peripherals such as microcontroller, crystal, reset circuit, power supply and so on

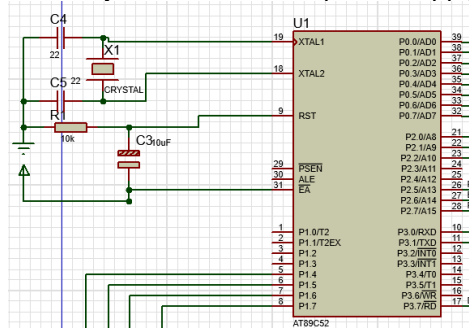

**Fig. 9 Minimum system based on AT89C52**

MOTOR-STEPPER is used to simulate the control of stepper motors. In Proteus, the stepper motor module usually consists of the following components. Stepper motor: is the actual stepper motor element, which usually consists of rotor, stator, coil, poles and bearings [7]. The ULN2003 module is chosen among the motor driver modules in this design. the ULN2003 can achieve current amplification through its internal relay array, which allows the output current of the module to be much higher than the current provided by the input circuit. Controller: This can be a microcontroller, digital circuit or other control device. It controls the motor driver module by sending out signals such as pulses, currents and voltages to drive the motion of the stepper motor. In this design the pulse control method is used, by periodically sending pulse signals to control the rotation of the stepper motor and the higher the frequency of the pulse, the faster the stepper motor rotates [8]. Power supply: provides the required power supply to the stepper motor and motor driver module. In Proteus software, the components of the stepper motor can be found in the preset component library or third-party library, which can be easily dragged and connected in the circuit design, and the control circuit of the stepper motor can be quickly established and simulated. Figure10 shows the circuit schematic of the stepper motor module.

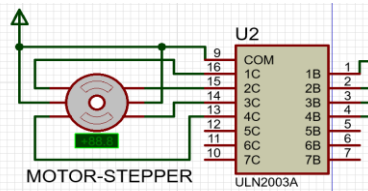

**Fig. 10 Stepper motor module circuit schematic**

The temperature sensor module uses DS18B20, and its circuit schematic is shown in Figure 11.

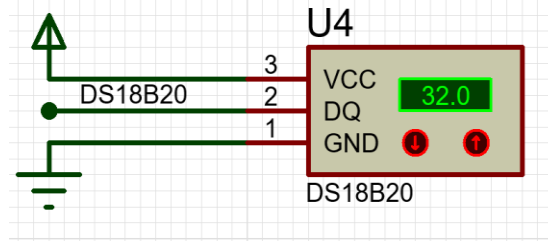

**Fig. 11 temperature sensor module circuit schematic**

This device needs to display the motor speed, temperature and set temperature, need to choose a display. LCD1602 is a 16 × 2 character type LCD display, consisting of 16 character columns and 2 character rows, each character consists of 5 × 8 pixel dots, can display a variety of characters, numbers and symbols, is widely used in electronic products as a display device [9]. Its display range is wide, LCD1602 can display a variety of characters such as English letters, numbers, symbols, Chinese characters, etc., which can be used in a variety of applications. In addition, due to the limited size of the LCD display, it is set to switch the display by pressing the key to meet the control requirements. LCD display module circuit schematic diagram is shown in Figure 12.

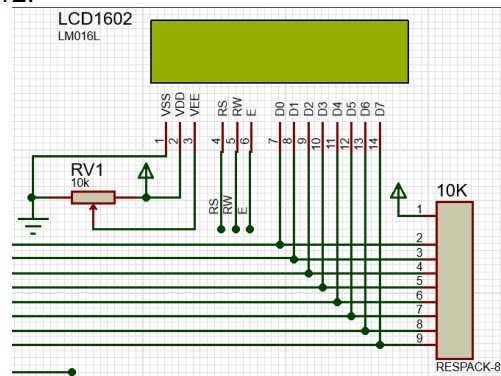

**Fig. 12 LCD display module circuit schematic**

In proteus, the key module is used to simulate the operation of buttons. As shown in figure 13, its the circuit schematic diagram of the key module of this device. k0 is the toggle button, by pressing K0, the LCD1602 interface will display the current motor speed, current temperature, and the set limit temperature respectively. In the motor speed page, the motor speed can be accelerated and decelerated respectively by pressing K1,K2. In the set limit temperature interface, the K1,K2 keys control the value of increasing the limit temperature and decreasing the set temperature respectively.

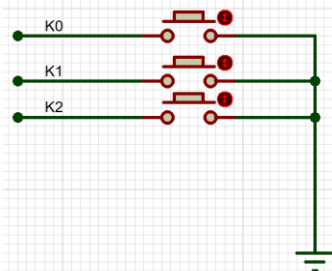

**Figure 13 Key Module Circuit Schematic**

## 4.2 PRESSURIZATION DEVICE SIMULATION CIRCUIT DESIGN

Pressurization device using Proteus software simulation model shown in Figure 14, mainly consists of the main control chip and the minimum system, water level detection module and A/D conversion module, stepper motor module, relay module, LCD display module, key module. Speaking program input simulation circuit to meet the design requirements.

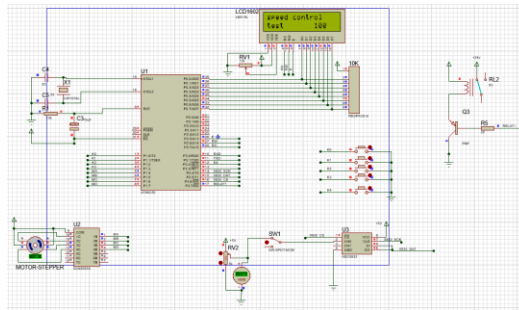

**Fig. 14 Simulation model of the control system of the pressurization unit**

The DC voltmeter is connected in parallel with the slide resistor to simulate the water level detection, and the voltmeter measures the voltage on both sides of the slide resistor, which is converted into the height of the water level and displayed on the LCD1602 display. In addition, by sliding the sliding varistor can be used to simulate the change of water level, in order to test the device control design is accurate [10]. In Proteus software, you can use ADC0832 components to simulate the work of the ADC chip, through simulation to verify the correctness and performance of the ADC circuit, to provide a reference for practical applications. The circuit schematic diagram of the water level monitoring module and the A/D conversion module is shown in Figure 15.

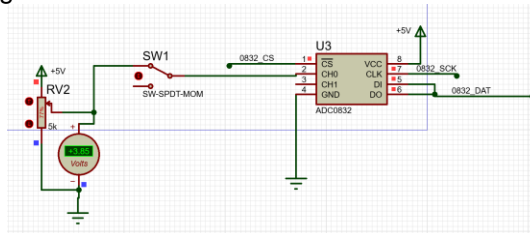

**Fig. 15 Water level monitoring module and A/D conversion module circuit schematic diagram**

As shown in Figure 16, it is the circuit schematic diagram of the relay module.

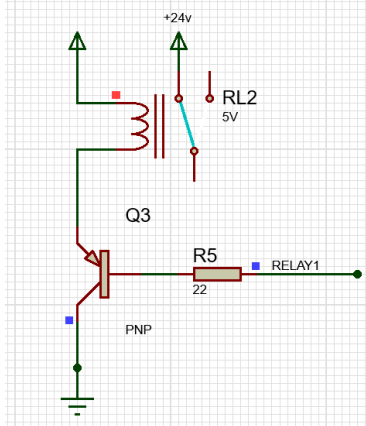

**Fig. 16 Relay module circuit schematic diagram**

Oil-water separation device using Proteus software simulation model shown in Figure 17, mainly composed of the main control chip and the minimum system, relay module, key module. Speaking program input simulation circuit to meet the design requirements.

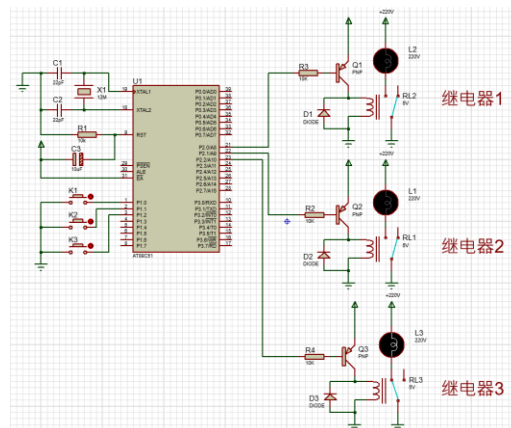

**Fig. 17 Simulation model of oil-water separation device control system**

## 4.CONCLUSION AND SUMMARY

A microcontroller-based control system was designed for the problem of oil slick pollution in the central trunk canal of the South-to-North Water Diversion. First of all, we consulted the information to determine the collection idea of intercepting first, then extracting, then separating. Then the control system is designed through the structure, first determine the required control system, the object of control, etc., and then select the required hardware by comprehensively considering the processor performance, function, demand, cost and other factors. Through the Proteus software, each component is connected, and the generated HEX file is imported to realize the simulation. Through the simulation, it can be seen that the functional integrity of the control system and the stability of the control system can be realized separately for the control of the collection device, pressurization device and oil-water separation device, and the simulation effect is very good and meets the design requirements.

## COMPETING INTERESTS

Authors have declared that no competing interests exist.

## AUTHORS' CONTRIBUTIONS

This work was carried out in collaboration among all authors. All authors read and approved the final manuscript.

## REFERENCES

1. Ren Jun. Technology and management of water quality safety in the main trunk canal of the south-to-north water transfer line[J]. Environmental Protection,2012(21):49-51.
2. LIU Gang,LIRuimeng,DUANRuirui,NIU Fu. Study on ecological compensation mechanism for sudden water pollution in South-to-North Water Diversion Project based on Nash bargaining game[J]. Journal of North China University of Water Conservancy and Hydropower (Natural Science Edition):1-11.
3. Sun Yujun, Li Danhua. Analysis of water quality status quo in the water source area of South-to-North Water Diversion Project[J]. People's Yangtze River,2016,47(14):15-18.
4. Zhang Q. Analysis of operation and management of DCS automatic control instrumentation system in metallurgical enterprises[J]. Automation Application,2019(01):54-55.
5. Zhao Xiafei. Research on governance mechanism of oil spill pollution in China's marine environment[D]. Shanghai:Shanghai Ocean University,2018.
6. QU Zhi. Practice of whole process management of environmental protection in Bohai oilfield[J]. Petrochemical Safety and Environmental Protection Technology,2017,33(05):8-13+1.
7. Xu Y. Preparation of carbon-based oil-absorbing materials with micro-nano hierarchical structure and its oil-water separation performance [D]. Shanghai:ShanghaiJiaotong University,2021.
8. Chen Xue,ChenQian,MaXiaomeng,YuJun,Yuan Jun. Preparation of superhydrophobic mesh and application in multi-stage parallel oil/water Preparation of superhydrophobic mesh and application in multi-stage parallel oil/water separation system[J]. Journal of Dispersion Science and Technology,2020,41(1).
9. Liu Yibo. Design and research on oil slick interception equipment for the mainline canal of South-to-North Water Diversion[D]. Zhengzhou, Henan: North China University of Water Conservancy and Hydropower, 2021.