

Technico-Economic Study of the Electrical Part of Drinking Water Supply System in the Village of Garin Maigari, Niger Center

Abstract

This study covers the technical and economic aspects of the electrical part of a drinking water supply system in the village of GARIN MAIGARI. This village is located in the Maradi region of Niger. The Mini AEP to be installed in the village has been sized in order to carry out the work. In the Maradi region, the average price of water is 500 FCFA/m³ for thermal AEPs and 375 FCFA/m³ for solar AEPs. On the Garin Maigari AEP, installations need to be monitored regularly to avoid exorbitant repair costs. If all the water were sold, the price per cubic meter would be 87 FCFA. The water supply system is economically profitable from the sale of 40% of daily production. For quantities of water sold at more than 40% of the pump's daily output, the price per cubic meter is therefore less than 220 FCFA. This price provides the necessary financial resources for after-sales service.

Key word:drinking water supply system, pumping of thermal, solar pumping, Generator pumping, energy consumption of pumps, water pumping system, photovoltaic pumping,

Introduction

Access to drinking water is a necessity for the health of populations. Indeed, according to[1], 26.3% of the world's population did not use a source of drinking water locally and still had to fetch water far from their localities. Given the Sustainable Development Goals (SDGs) target of universal access and Ensuring equitable (i.e. 100%) access to water by 2030, it is important to consider the impact on this goal of the collection load, in terms of time or distance. In this regard, the indicator for tracking progress has been defined as the proportion of the population using safely managed drinking water services, which include the concepts of accessibility, availability and quality [1]. So many of the world's poorest people are waiting for water. Most of these people live in the countries of the South, in Asia and Africa [2]. They are waiting for the modernist development of the 20th century to fulfill its promise of bringing clean drinking water through centralized supply networks to every home, in every corner of every country in the world. But they're still waiting for that promise to become a reality. They are waiting for this larger project, but they are also waiting daily for the water collection pipes in public standpipes [3], for intermittently supplied water to come out of household taps [4], for water to be discharged into canals [5]and for groundwater to flow slowly to dug wells and tubewells [6, 7]. This waiting disproportionately affects women, who bear primary responsibility for meeting household water needs, and children, who do much of the waiting and collecting alongside their mothers [8, 9, 10, 11, 12].

Many African countries are trying to bring drinking water to remote areas not connected to water utilities. Many of these countries have opted to build drinking water supply systems with strategic partners. Niger, one of Africa's poorest countries, has opted for the delegated management of drinking water systems to ensure the long-term viability of its facilities. Its optimization involves many aspects, such as pipe network layout, water consumption, pump group types, clean water reservoir and electricity costs [13, 14]. The rate of access to drinking water in Niger is 90% in urban areas and 45% in rural areas. The use of drinking water conveyance systems is one of the methods used to supply drinking water to both the rural and urban population. The water distribution system is a critical infrastructure in both urban and rural areas [15].

Solarizing or hybridizing (solar/thermal) the pumping of thermal MAEPs represents a considerable opportunity to reduce the price of water in rural areas, where the cost of water is much higher than in towns. The savings achieved with solar pumping (around 125 FCFA/m³) could make it possible to envisage a total concession (excluding the borehole), with a solar-pumped MAEP and a selling price of 500 FCFA/m³.

Unlike the concessive island, the concession would remove the subsidy effect of the initial investments, which would nevertheless reduce the price of water.

In most water supply systems, the borehole and reservoir are provided by the state or a charitable organization. The delegator is responsible for the purchase or installation of PV generators and solar pumps, or for maintenance only. The delegator's investments range from 15% to 100%. In our study, we have excluded drilling, reservoir and other costs. It should be noted that the overall cost of a Mini AEP in Niger ranges from 50,000,000 to 80,000,000 FCFA.

As part of this study, it is carried out a dimensioning of the GARIN MAIGARI Mini AEP through a technico-economic study of the electrical part. The operational management of mini AEPs is a subject of growing interest, given the economic and environmental factors [16]. Optimal control of the pump group has proven to be a practical and effective method of reducing operating costs for the entire drinking water supply system [17, 18]. Depending on the number of variables and optimization objectives, the problem of optimal pump group control can become very complex, especially in large systems.

Materials and Methods

Presentation of the Niger Study Area and Energy Potential

The study area is a village in the rural commune of Safo in the Madarounfa department of the Maradi region. Niger has a high level of sunshine throughout its length, with maxima in its northern part. Sunshine is fairly regular, except in August. Average monthly values range from 5 to 7 kWh/m² per day, and the average duration of sunshine is 8 hours per day. This state of affairs offers significant potential for the development of solar energy in Niger at competitive costs. In the village of GARIN MAIGARI, in the rural commune of Safo in the Maradi Region, we found an average sunshine level of 5.75 kWh/m² /d (Figure 1).

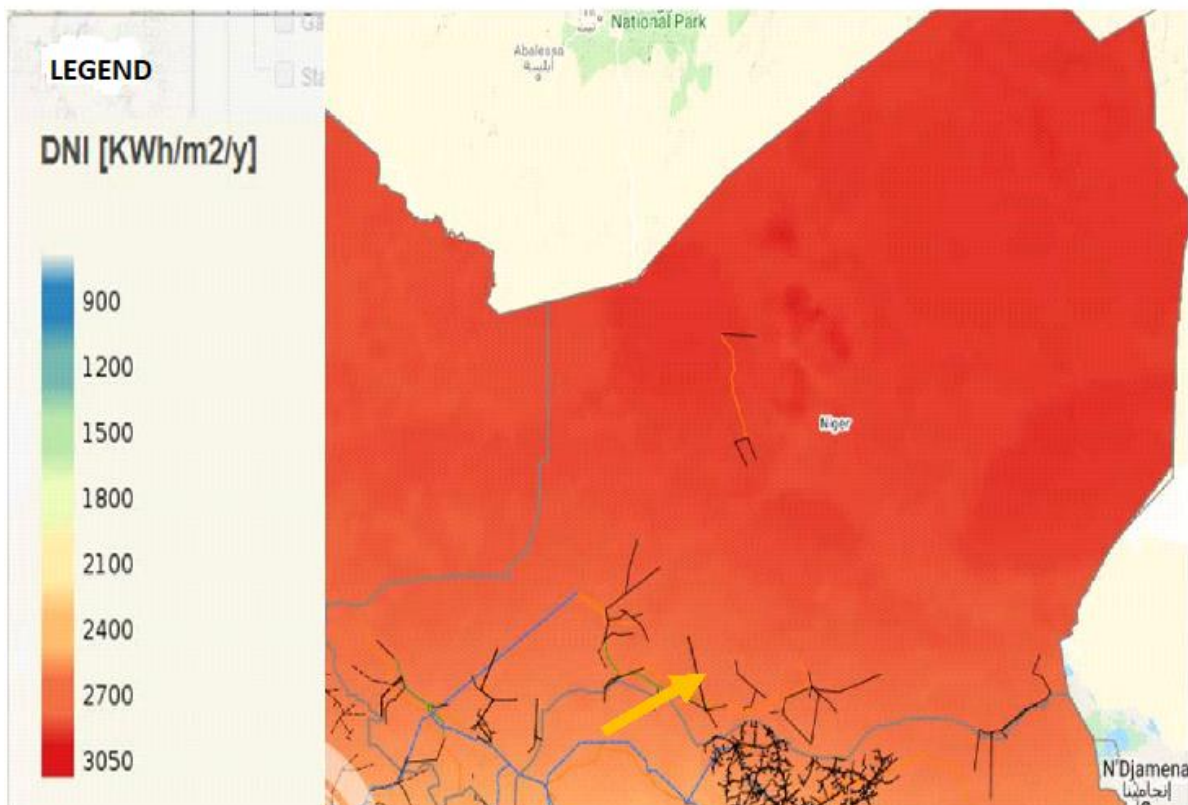

Fig.1. Sunshine map of Niger

Sizing parameters

Sizing requires knowledge of drilling standards and parameters.

Estimated water requirements

Drinking, cooking, washing and bathing are the main uses of water for human needs. Animals also need water for their survival. Water is also essential for agriculture and industry, whatever their scale. The World Health Organization has defined the water needs of people and their concerns (Table 1).

Table 1: Water requirements [19]

Humans	Animals	Irrigation
5 l/day survival	Beef 40 l/day	Village-wide cultivation 60 m ³ /day/ha
10l/day minimum admissible	Sheep, goat 5 l/day	Rice 100 m ³ /day/ha
30 l/day normal living conditions in Africa	Horse 40 l/day	Seeds 45 m ³ /day/ha
	Donkey 20 l/day	Sugar cane 65 m ³ /day/ha
	Camel 20 l/day (reserve of 8 days)	Cotton 55 m ³ /day/ha

Flow estimation

Flow rate (Q) is the quantity of water the pump can deliver during a given time interval. In pumping, flow rate is usually given in liters per hour (l/h) or gallons per hour (gp/h). In solar pumping, the flow rate (or water requirement) is often expressed in m³ per day. Solar pumps generally operate between 9:00 and 16:00.

Calculating total head

The total head of a pump is the pressure difference in meters of water column between the suction and discharge ports.

$$\text{HMT} = H_g + P_c \text{ [20](Camille Evain, 2020)}$$

H_g = geometric height

P_c = pressure drop

Losses are a function of pipe length (L), pipe diameter (Dc) and pump flow rate (Q), and are expressed in meters of water. Pipe diameters should be calculated so that these head losses correspond to 5% to 10% of the total pipe length.

The static level (N_s) of a well or borehole is the distance from the ground to the water surface before pumping.

The dynamic level (N_d) of a well or borehole is the distance from the ground to the water surface for pumping at a given flow rate. To calculate the HMT, the dynamic level is calculated for an average flow rate. The difference between the dynamic level and the static level is called the drawdown. R_m is the maximum acceptable drawdown before stopping the pump.

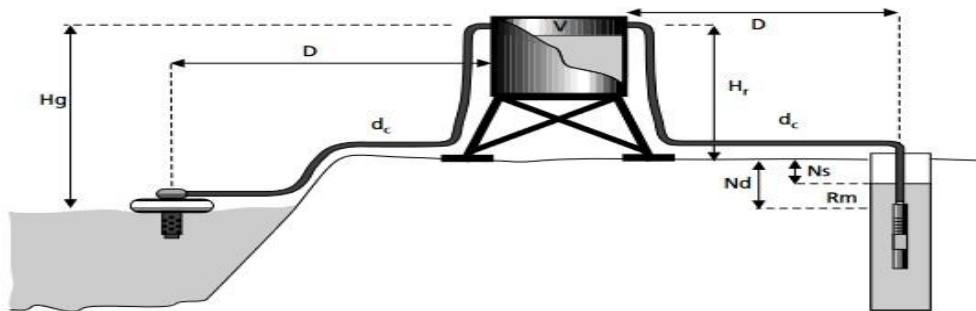

Fig.2. HMT parameter [20]

Calculation of design parameters and economic analysis

Technical and financial factors must be taken into account for proper sizing.

Calculating design parameters

When you know the data and the conditions of use of the drinking water supply, sizing becomes easy.

Calculation of electrical energy required per day

The aim of solar pumping is to raise a certain quantity of water to a certain height every day. This requires a certain amount of mechanical energy. To calculate the electrical energy to be supplied to the motor-driven pump (E_1), we need to take into account the pump's efficiency, which varies according to the type of pump. If the efficiency of the motor-driven pump is unknown, the reference values (Table 2) should be used:

Table 2: Efficiency according to pump type [1].

PUMP TYPE	Volumetric	Centrifugal (< 2HP)	Centrifugal (> 2HP)
Reference yield	0,6	0,4	0,6

The formula for calculating daily electrical energy in Watt-hours per day (Wh/day)

$$\text{Daily electrical energy } (E_1) = \frac{2,725 \cdot Q \cdot \text{HMT}}{R_{\text{pompe}}} \quad [1]$$

Q: volume flow in m^3/d

HMT: manometric head in m

2.725 water hydraulic constant

R_{pompe} : motor pump efficiency

Pump capacity calculation

Generally speaking, the nominal flow rate of the installed pump is equal to one fifth of the daily energy required. From this we can deduce the pump power: Pump electrical power (P1) = $\frac{E1}{t}$ [1]

t: operating time

E1: daily electrical energy (Wh/d)

Generator power calculation

When powered by a variable energy source, such as solar panels that produce more or less, pump start-ups are progressive. This is not the case with generator power. In the case of a generator supply, the generator is started up, and when the generator output circuit breaker is switched on, the pump is suddenly energized, reaching full power in just a few milliseconds. This sudden surge of power from the electric motor generates strong magnetic fields, which the generator must overcome before the electric motor can start. This phenomenon is known as "starting load impact".

To avoid this, the following sizing rule should be observed:

Generator power (in VA) = Pump electrical power (P₁) * 3 [20]

Calculating the power of solar panels to be installed

Panel output depends on the light power received from the ground, the installation method (see "solar tracking" option), a loss of yield due to maintenance (dust film) and panel ageing over time. Regularly observed photovoltaic park yields are shown in Table 3.

Table 3: Efficiency as a function of panel substrate type and operating conditions [1].

Choice of efficiency factor	Fixed installation of solar panels	Horizontal axis suntracking	Inclined or vertical axis sun tracking	Automatic sun tracking on 2 axes
Reference performance in dusty or dusty environments poor panel cleaning	0,5	0,6	0,7	0,8
Reference yield in medium clean or regular cleaning of panels	0,6	0,7	0,8	0,9

$$\text{Total power of panels to be installed} = \frac{\text{Energie électrique journalière } E1 \left(\frac{\text{Wh}}{\text{jour}} \right)}{\text{Rayonnement journalier } \left(\frac{\text{KW}}{\text{m}^2 \cdot \text{jour}} \right) \cdot \text{Rendement}} \quad [1]$$

$$\text{Number of panels} = \frac{\text{Puissance totale à installer}}{\text{Puissance d'un panneau}}$$

Voltage selection

The choice of inverter depends on the pump to be powered. The inverter's power must be greater than, or equal to, that of the pump. However, the solar generator voltage is imposed by the inverter ($V_{\text{system}} = \text{inverter input voltage}$).

Economic analysis

The economic analysis takes into account all the costs of the parameters required to ensure continuity of service.

From the investor's point of view, discounted pump costs enable cost comparisons between different options. Its importance is linked to the fact that some options require large initial investments and relatively low operating and maintenance costs, while others present the opposite situation. Under these conditions, a cost analysis will need to include the cost of capital financing, as well as the present value of operating, maintenance and replacement costs over the expected lifetime of the pumping system. This analysis is called the

Life cycle costing.

From an investor's or financier's point of view, calculating the cost of a pump must include all the costs that will ensure its viability over a certain period of time, reduced to a present value. This makes it possible to compare costs on a common basis with other options, and thus find the most economical choice.

The basic principle of this economic analysis is to establish the initial investment cost of the installation, the annual operating and maintenance costs, and the cost of replacing equipment; all in present value terms over the system's lifetime:

The choice of system lifetime is normally linked to the maximum lifetime of a system's main equipment. In order to compare several options, the same lifetime should be used, even if this means including essential equipment replacements for certain options. In our calculations, the choice of economic lifetime is linked to the fact that the estimated lifetime of photovoltaic modules is normally 20 years[21] [22].

Other important parameters to consider in an economic analysis are the interest rates at which systems can be financed, and the discount rates for the future value of the various costs. The interest rate is often a function of the credit available to the investor. In developing countries, an interest rate of 10% is considered relatively low. Some lenders may, of course, be able to offer better borrowing conditions to encourage the development of certain options. The discount rate is also a function of the rate of inflation and the rate of investment available during the period covered by the analysis. Each country's economic situation is different, and the rate of investment varies from market to market. For our analysis, we have set the inflation rate at a relatively low level, 3%, and the investment rate at 8%, giving us a discount rate of 5%.

$$\text{Simple discount coefficients} = \frac{1}{(1+i)^n}$$

$$\text{Uniform discount factor} = \frac{1-(1+i)^n}{i}$$

$$\text{Coefficient for annuity} = \frac{i \cdot (1+i)^n}{(1+i)^n - 1}$$

Annuity value = initial value * annuity coefficient

Present value = annuity value * uniform discount coefficient

Present value = present value * annuity factor for calculating present value of replacement costs

Present value = present value * uniform discount factor for calculating present value of maintenance and operating costs

Discounted cost = initial cost (in some cases) + operating and maintenance costs + cost of auxiliary energy + replacement (including time and transport) + buy-back value (-10%)

Results and discussion

Estimated water requirements

The drinking water supply system is designed for 100 families of 10 people each, i.e. a population of 1,000. Each person consumes 20 l/d for personal needs, so 20 m³ /d for the inhabitants. Daily requirements are estimated at 40 m³ /day, with 20 m³ /d for the storage tank.

Head calculation (HTM)

The village will be supplied by a 57 m-deep borehole and a reservoir located 6 m above ground level. The total length of the pipeline is 80 m to limit pressure losses. The daily flow rate is 40m³ /day, with 20 m³ for storage. Head losses are estimated at 5% of the total pipe length.

The HMT is then calculated by :

$$N_d : 51 \text{ m Hg} = 57 \text{ m H}_R : 6 \text{ m Pc} = 4 \text{ m HMT} = \text{Hg} + \text{Pc} = 57 + 4 = 61 \text{ m}$$

Calculation of electrical energy required per day

Knowing the daily flow rate, the type of fluid to be pumped and the head, we can deduce the energy required.

$$\text{Daily electrical energy (E}_1\text{)} = \frac{40 \left(\frac{\text{m}^3}{\text{jour}} \right) \cdot 61 \text{ (m)} \cdot 2,725}{0.6} = 11081,6667 \text{ wh/j}$$

Pump capacity calculation

The total daily requirement is 40 m³ /d, of which 20 m³ /d and the reservoir has a capacity of 20 m³ . A pump with a flow rate greater than or equal to 8 m³ /h is chosen to operate for 5 hours a day. The pump selected is a 3*380, 3HP (horse power) 2.2 kw three-phase pump type 4SP8 with 7.2 m³/h at HMT 61 m. The energy required to run the pump is 11 kWh/d for 5 hours of operation.

$$\text{Pumpelectrical power (P}_1\text{)} = \frac{11000 \left(\frac{\text{wh}}{\text{jour}} \right)}{5} = 2,2 \text{ kw}$$

Calculating the power of solar panels to be installed

The total power of panels to be installed can be calculated using the following formula:

$$\text{Total power of panels to be installed} = \frac{11081,6667 \left(\frac{Wh}{\text{jour}}\right)}{5,75 \cdot 0,6} = 3212,0773 \text{ kw}$$

The unit power of the available panels is 200 Wp, with nominal voltage 38.8 V and nominal current 5.8 A. The inverter input voltage is around 600 V.

$$\text{Number of serial branches} = \frac{600}{38,8} = 15,46$$

To avoid undersizing, we consider 16 panels in series. The installed power is = 16*200= 3200 W.

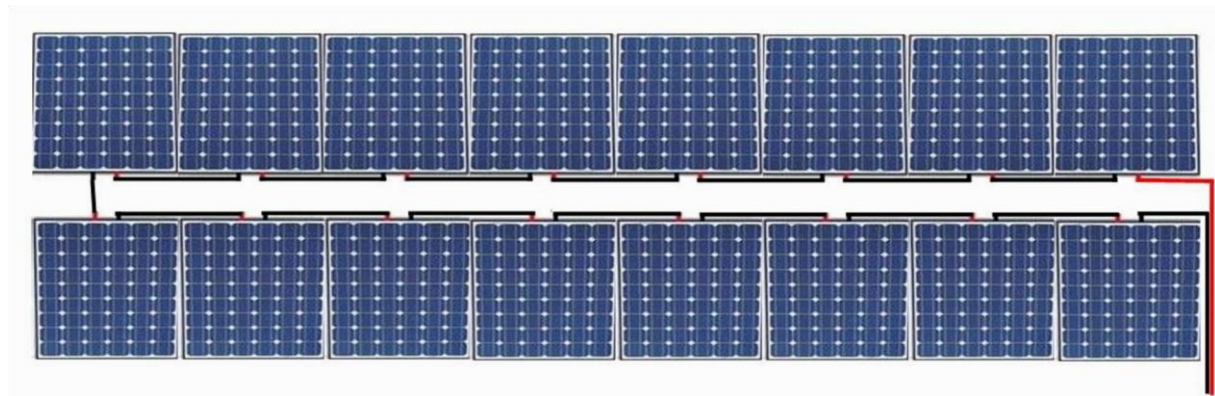

Figure 3: series connection of photovoltaic panels

Inverter power calculation

As the pump has a power of 2.2 Kw, the inverter chosen is the RSI3000 with a power of 3 Kw, a DC input voltage of around 600 V and an output voltage of 3*380 V.

Calculating cable cross-sections

DC current is of the order of 5.8 A, choose a 1.5 mm² cross-section cable 1m long between the inverter and the panels. AC current is of the order of 9A, choose a 6 mm² cross-section cable 60 m long from the pump to the inverter.

Choice of accessories

The DC current is of the order of 5.8 A and the voltage is 600 V. A CE-type circuit breaker and IEC 60047-type switches are selected. The probe is type 010748.

Financial part

This section presents the cost of production when all production is sold, and the cost of sale per volume of water sold.

Cost per cubic meter for a sale of total production

Table 4 shows the cost per cubic meter of water when total production is assumed to be sold. In the economic calculation, we considered the following recurring costs:

- Operating costs (fountain attendant and janitor) including minor maintenance: FCFA 520,000 ;

- Cost of after-sales service (full 20-year warranty, the cost of replacing equipment is covered by the after-sales service, but replacement annual instalments are paid to the after-sales service manager) ;
- Maintenance cost 260000 FCFA ;
- Equipment replacement every 7 years: pump: FCFA 1000000, inverter: FCFA 2700000.

Table 4: Estimated cost per m³ of water

Economic parameters						
Position	Duration of period (years)	Present value	Coefficient For annual instalments	Simple discount coefficient	Uniform discount factor	Present value (FCFA)
Initial cost						
Cost of components 7000000						
One-off payment	0	-	-	1,000	-	-
Annuities	20	822 500	0,1175	-	12,462	10 249 995
Transport and Installation	0	600000	-	1,000	-	600000
Operation and Maintenance						
Operating costs	20	520000	-	-	12,462	6480240
Maintenance costs	20	260000	-	-	12,462	3240120
Cost of auxiliary energy						
Cost of diesel (annual)						
Cost of electricity(annual)						
Replacement (including time and transport)						
Pump	7	1000000	0,711	-	-	711 000
Inverter	10	2700000	0,614	-	-	1 657 800
Surrender value						
10%	20	700000	0,377	-	-	2 639 000
Present cost						25578155
Cost per Wp						7253,333
Water cost per m ³						175,1928

Evaluation of the cost of the m³ based on recurring expenses

Let's take the example of the typical solar pump station mentioned in the section on calculating the cost of the solar pump. In the economic calculation, we had concluded that the expenses linked to the initial cost the other expenses remain unchanged as in the previous case.

The average sales flow is 20 m³ per day. Considering that water is sold by volume, the price per cubic meter of water sold will have to be set to cover recurring costs as a minimum. In this typical case, we consider that the initial costs are not borne by the users, who will nevertheless have to replace the solar generator at the end of its useful life in order to ensure uninterrupted service. If all the water is sold, the price per cubic meter of water would be 87 FCFA (table 5).

As it is unlikely that all the water pumped will be sold throughout the year, we need to estimate the proportion of water that will actually be sold. For example, assuming that 30%, 40% or 60% of the water pumped will actually be sold, we obtain the following prices per cubic meter:

- Assumption 30% : 290 FCFA/m³ ;
- 40% assumption: 220 FCFA/m³ ;
- 60% assumption: 150 FCFA/m³ .

For quantities of water sold at over 40% of the pump's daily output, the price per cubic meter is therefore less than 220 FCFA. This price provides the financial resources needed to pay for after-sales service.

Table 5: Estimated cost per m³ based on recurring costs

Economic parameters						
Position	Period duration (years)	Present value	Coefficient For annual instalments	Simple discount coefficient	Uniform discount factor	Present value (FCFA)
Initial cost						
Cost of components 0FCFA						
One-off payment	0	-	-	1,000	-	-
Annuities	0	0	0,1175	-	12,462	0
Transport and Installation	0	0	-	1,000	-	0
Operation and Maintenance						
Operating costs	20	520000	-	-	12,462	6480240
Maintenance costs	20	260000	-	-	12,462	3240120
Cost of auxiliary energy						
Cost of diesel (annual)						
Cost of electricity(annual)						
R location (including time and transport)						
Solar Panel	20	1600000	0,377	-	-	603200

Pump	7	1000000	0,711	-	-	711000
Inverter	10	2700000	0,614	-	-	1657000
Presentcost						12691560
Cost per Wp						3599,0131
Cost of water per m ³						86,92849

Conclusion

This study carried out a dimensioning of the GARIN MAIGARI Mini AEP through a technico-economic study of the electrical part. According to the result of this study the development of photovoltaic pumping has led to a substantial reduction in the cost and sale price of water at the MAEP level in the Maradi region. The average price of water is 500 FCFA/m³ for thermal APRs and 375 FCFA/m³ for solar APRs. On the Garin Maigari AEP, installations need to be monitored regularly to avoid exorbitant repair costs. If all the water were sold, the price per cubic meter would be 87 FCFA. The water supply system is economically profitable when 40% of daily production is sold. For quantities of water sold at more than 40% of the pump's daily output, the price per cubic meter is therefore less than 220 FCFA. This price provides the financial resources needed to pay for after-sales service.

References

[1] UNICEF & WHO Progress on Sanitation and Drinking Water 2015 Update and MDG Assessment. 2015

[2] UNICEF, Progress on drinking water and sanitation. World Health Organization. (2014).

[3] Birkenholtz, T. "Full cost recovery: Producing differentiated water collection practices and responses to centralized water networks in Jaipur. India Environment and Planning A, 42, 2238-2253. 2010.

[4] Loftus, A. Reification and the dictatorship of the water meter. Antipode, 38, 1023-1045. 2006.

[5] Barnes, J. Cultivating the Nile: The everyday politics of water in Egypt. Durham and London: Duke University Press. (2014

[6] Birkenholtz, T. On the network, off the map: Developing inter-village and intra-gender differentiation in rural water-supply. Environment and Planning D: Society & Space, 31, 354-371. 2013

[7] Birkenholtz, T.. Drinking water. Eating, Drinking: Surviving: The International Year of Global Understanding-IYGU, 23-30. 2016

[8] Sultana, F. Gendered waters, poisoned wells: Political ecology of the arsenic crisis in Bangladesh. In K. Lahiri-Dutt (Ed.), Fluid bonds: Views on gender and water (pp. 362-386). 2006

[9] Hawkins, R., Ojeda, D., Asher, K., Baptiste, B., Harris, L., Mollett, S., et al. Gender and environment: critical tradition and new challenges. Environment and Planning D-Society & Space, 29, 237-253. 2011

[10] Nightingale, A. J. Bounding difference: Intersectionality and the material production of gender, caste, class and environment in Nepal. Geoforum, 42, 153-162. 2011

[11] Sultana, F. Fluid lives: subjectivities, gender and water in rural Bangladesh. Gender Place and Culture, 16, 427-444. 2009

[12] Truelove, Y. (Re-)Conceptualizing water inequality in Delhi, India through a feminist political ecology framework. Geoforum, 42, 143-152.2011

[13] Birkenholtz, T. On the network, off the map: Developing inter-village and intra-gender differentiation in rural water-supply. Environment and Planning D: Society & Space, 31, 354-371. 2012

[14] Z. Zhang, Y. Zeng and A. Kusiak, "Minimizing pump energy in a wastewater processing plant", Energy, vol. 47, no. 1, pp. 505-514, Nov. 2012.

[15] Z. Zhang, A. Kusiak, Y. Zeng and X. Wei, "Modeling and optimization of a wastewater pumping system with data-mining methods", Appl. Energy, vol. 164, pp. 303-311, Feb. 2016.

- [16] H. Yu, T. Zhao and J. Zhang, "Development of a distributed artificial fish swarm algorithm to optimize pumps working in parallel mode", *Sci. Technol. Built Environ.* vol. 24, pp. 248-258, Mar. 2018.
- [17] P. Olszewski, "Genetic optimization and experimental verification of complex parallel pumping station with centrifugal pumps", *Appl. Energy*, vol. 178, pp. 527-539, Sep. 2016
- [18] Z. Zhang and A. Kusiak, "Models for optimization of energy consumption of pumps in a wastewater processing plant", *J. Energy Eng.*, vol. 137, no. 4, pp. 159-168, Dec. 2011
- [19] R. Menke, E. Abraham, P. Parpas and I. Stoianov, "Extending the envelope of demand response provision through variable speed pumps", *Procedia Eng.* vol. 186, pp. 584-591, 2017.
- [20] Eric Schiller, *manuel de cours à l'intention des ingénieurs et des techniciens, Institut de l'énergie des pays ayantencommunl'usage du français*, 281 pages . 1998
- [21] Camille Evain, *solar pumping design and realization of the electrical part of the pumping, Action Contre la Fain*, 40 pages. 2020
- [22] Cassivi, A., Johnston, R., Waygood, E. O. D., & Dorea, C. C.. *Access to drinking water: time matters. Journal of Water and Health*, 16(4), 661-666. 2018