

Original Research Article

Using Arduino to monitor temperature and relative humidity of the air used and that of the synthesis gas in a biomass gasifier

Abstract

Gasification of biomass can be done with pure oxygen or with ambient air. We have chosen gasification with ambient air in our project for costs considerations. Relative humidity (RH) of the air we used with a downdraft co-current gasifier is monitored in this paper. RH sensor used in this paper presents a capacitor which depends on the amount of water contained in the gaseous mixture. That RH, behaving as a variable capacitor is inserted in serial with the RC circuit of an astable multivibrator. Frequency of the oscillator is dependent of the resistance and the capacity which depends on the RH. From the RH sensor datasheet, a mathematical model has been developed and the equation giving RH found. The effect of temperature on the RH is also taken into account. Using Arduino Uno3 as a computer, we have calculated corrected RH respective to temperature and displayed both ambient and real RH on 20 columns with 4 lines LCD display. Arduino has also enabled us to save measured data in an Excel sheet, allowing us to analyses measured temperature and RH and plot different curves from it. The same circuit is also used to monitor RH of produced synthesis gas. Results of the Arduino temperature and monitoring system shows that visual observation of air and human feeling can be very misleading in respect to the air RH.

Keywords: Biomass, Gasification, Relative humidity, Temperature, Sensor.

1. Introduction

Biomass gasification has attracted interest in decentralized energy production because it offers flexibility, ubiquity of products, the possibility to store energy in other forms as liquid [1],[2], [3],[4], [5].

Despite the abundance of waste of agricultural, vegetable and household origin, the large-scale exploitation of this conversion process is very little developed in Burkina Faso. In a bibliographic review made in 2014, it was established that gasification of waste may be an interesting alternative for Burkina Faso [6]. In his PhD thesis dissertation, Barry [7] stated that: “The syngas production sector by gasification of mobilizable residues can only be competitive with the butane gas market if the technology is manufactured locally.” His assertion is corroborated by the study carried out by Hamed [8].

In fact gasification units were installed at Dano, Po and Bama in Burkina Faso. But these projects didn't fully success, even if they had gasification units technologies that are in production elsewhere in the world. However gasification still appears as feasible in Burkina Faso, provided some economical and technical considerations be taken in account [7]. Therefore, we have a challenge to locally manufacture gasification units for electrical power generation in Burkina Faso.

With these considerations in mind, we are in the process of designing and thoroughly testing small-scale gasifiers in order to better master the gasification technology with locally manufactured units.

Comment [U1]: It's better to write [1-5]

Comment [U2]: Connect this with the previous sentence

Comment [U3]: It's better to make a paraphrase statement from Barry's research results

Comment [U4]: Change to : However, these projects did not fully success.

In Burkina Faso, several biomass gasification units have been installed in 3 secondary town. **But** these have not commercially succeeded for several reasons. Our laboratory has an energetic team who have built two laboratory scale gasifiers from May to December 2022 [9], [10]. The two gasifiers built are of the co-current type we have chosen because these appeared to us the easiest to build on small and laboratory testing scale as documented by other authors [11], [12], [13], [14], [15]. One of the important operating parameters of the gasification is the air flow and moisture content of the biomass feedstock.

Comment [U5]: Use However rather than But.

Comment [U6]: Write [9-10]

Comment [U7]: Write [11-15]

By varying the moisture content from 11 to 30%, at a fixed equivalence ratio on the gasifier of 0.2609, Dillip Kumar Mohanty and Abhijit Padhiary [16], found that steam gasification gives more yield of fuel while the temperature reduces with moisture content. The optimum moisture content to maximise the fuel content maintaining the reaction temperature at 1,000 K was found to be 18% to 19%. **Othe** authors also showed that humidity inside biomass and relative humidity of the air sed for gasification greatly impact the gasification process [17], [18], [19], [20].

Comment [U8]: Write only last name of the authors

Comment [U9]: ?

Comment [U10]: [17-20]

Though we successfully operated our gasifiers on may 2022 and November-December 2022, we were unsuccessful on September 2023. It came out that relative air humidity was in the range of 70% in September 2023 at Koudougou, Burkina Faso where we held our experiments.

Therefore, we ran to the conclusion that relative humidity of air should be mastered in order to enable us conduct gasification experiments at any time.

Consequently, with a view to improving the performance of the gasifiers, a module for dehumidifying the ambient air used by the gasifier was designed. This module is based on Peltier effect cooling and aims to reduce air humidity below the limit of 25% relative humidity of December 2022 we measured and beyond which the gasification of biomass would be strongly degraded. According to the RH sensors, there a dependency to temperature. Therefore, effect of temperature on RH is taken in account in order to have more accurate RH.

In order to achieve these requirements, relative humidity must be monitored at the entrance of the dehumidifier and at the exit of the dehumidifier before entering the gasifier.

For that purpose, robust, industrial grade relative humidity sensors were souk in order to buildan adapted relative humidity survey system for our gasifiers.

We also found that a microcontroller can be used to acquire data from numerous sensors, compute several mathematical functions and display these values [21], [22], [23].

Comment [U11]: [21-23]

2. Materials and Methods

2.1 Experimental setup

The gasifier used in this work is composed of several four functional units: the reactor, the cyclone, the water condenser and the filter as depicted on Figure 1 below.



a: Reactor b: Cyclone c: Water condenser + filter

Figure 1 :Experimental setup

In our project, we have 3 RH modules. Two these are located in the dehumidifier module (referred to as the air blower) and the third is located on a sampling box that draw a small amount of synthetic gas cleaned of tar and water vapor by the cyclone separator, the condenser and the filter. This paper focus on the third RH module that is already installed on a synthesis gas sampler located near the filter. The same design applies to the two other RH of the air dehumidifier.

2.2 Methods

2.2.1 Presentation of the RH sensor

For humidity measurement, we used the HS1101 sensor [24]. Its sensitive element is a capacitor whose dielectric is made up of a hygroscopic substance (polymer for example) a few micrometers thick which absorbs the water molecules contained in the ambient air until reaching equilibrium with the steam. of water contained in humid air. This causes a variation in the dielectric constant of the hygroscopic layer and consequently a variation in the capacitance of the capacitor [25], [26], [27].

The electrical model of the humidity sensor has a capacity according to Figure 2 below:

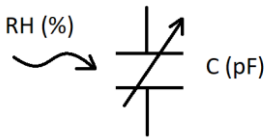

Figure 2 :Electrical model of RH sensor

The parameters are:

RH: relative humidity in %,

C: the capacitance of the sensor in Picofarad (pF).

2.2.2 Schematic circuit and RH calculation principle

We have built an oscillator according to the electronic circuit on Figure 3 below using a NE555 integrated circuit to generate a square wave signal.

Comment [U12]: place it in the middle of the manuscript

Comment [U13]: Use one writing color

Comment [U14]: write [25-27]

Comment [U15]: place it in the middle of the manuscript

of which the frequency depends on the capacity of LS110LF RH sensor.

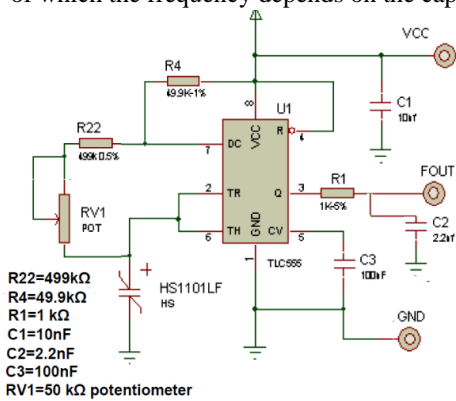

Figure 3 : Square signal generator

F_{out} on the schematic is the output frequency of the oscillator.

The HS1100/HS1101, used as variable capacitor, is connected to the TRIG and THRES pin.

Pin 7 is used as a short circuit pin for resistor R_4 .

The HS1100/HS1101 equivalent capacitor is charged through R_2 and R_4 to the threshold voltage equal to (approximately $0.67V_{cc}$) and discharged through R_2 only to the trigger level (approximately $0.33V_{cc}$) since R_4 is shorted to ground by pin 7.

Since the charge and discharge of the sensor run through different resistors, R_2 and R_4 , the duty cycle depends on these resistors.

2.2.3 Calculation of the RH

The calibration curve of the RH sensor given by the manufacturer [24] is the following:

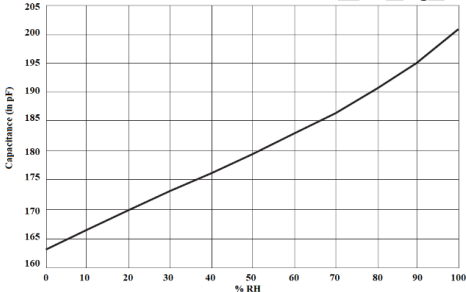

Figure 4 : HS1101 typical response

By taking points from this calibration curve, we obtain Table 1 below:

Table 1 RH sensor value provided by manufacturer

Rh(%)	0	10	20	30	40
C(pF)	162.86	166.43	170	172.86	176.07

50	60	70	80	90	100
181.43	182.86	188.43	190.71	195	200.7

From this table we obtained the following correlation curve on Figure 5 below.

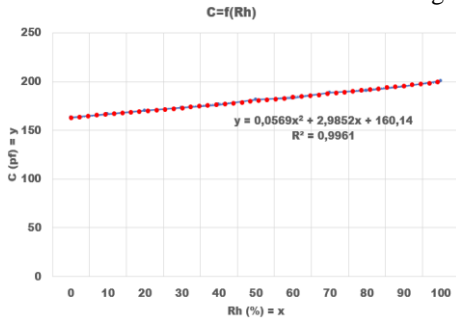

Figure 5 : Capacity as function of relative humidity

By a second order polynomial interpolation in the least squares sense, we find:

$$C = 7.10^{-4}(Rh)^2 + 0.2921(Rh) + 163.39 \text{ Eq. 1}$$

For an operating point of relative humidity around 55%, we find

$$C(55\%) = 181.573 \text{ pF} \quad \text{Eq. 2}$$

To simplify the calculations, let's take the Table 1 again by considering the ratio (C/C_{55}) and Rh. We obtain Table 2 below.

Table 2 : relative humidity as function of C/C_{55}

Rh(%)	0	10	20	30	40
(C/C_{55})	0,8969	0,9165	0,9362	0,9519	0,9696

50	60	70	80	90	100
0,999	1,007	1,027	1,050	1,074	1,105

From this Table 2, the expression (by linear polynomial interpolation in the least squares sense) of RH as a function of C/C_{55} is then:

$$Rh = 496.23 * (C/C_{55}) - 443.26 \quad \text{Eq. 3}$$

2.2.4 Determination of the temperature

A K type thermocouple is used along with its amplification and analog to digital converter referenced as Max6675 to acquire the working temperature of the part where the RH sensor is plugged in.

According to the manufacturer datasheet [28], the MAX6675 can measure temperatures from 0°C to +1024°C, performs cold-junction compensation and digitizes the signal from a type-K thermocouple.

The data is output in a 12-bit resolution, serial peripheral interface (SPI) compatible, read-only format. On Figure 6 below, the Max6675:

Comment [U16]: create clearer images with the same font as the script

- processes the reading from the thermocouple and transmits the data through a serial interface.
- Force CS low and apply a clock signal at SCK to read the results at SO. Forcing CS low immediately stops any conversion process.
- Initiate a new conversion process by forcing CS high.
- Force CS low to output the first bit on the SO pin.

That way, Max6675 gives us a compensated temperature reading from ambient temperature to the working temperature of the Lambda sensor. Conversion in K is made in the Arduino Integrated Development Environment (IDE).

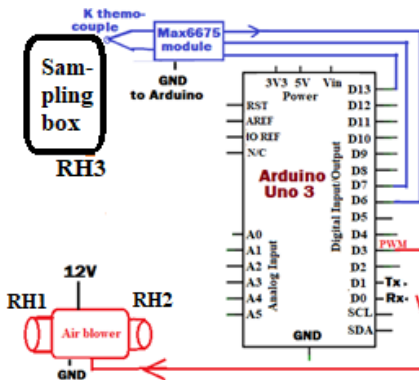

Figure 6: Overall diagram of the monitoring system

The Max6675 outputs a digital value of the temperature on pin DO. That value is read on seventh digital pin D6 of the microcontroller and can be used for calculations.

2.2.5 Relation to gasification

In case of gasification, we seek to produce mainly carbon monoxide and hydrogen, plus sometime methane.

The stoichiometric combustion of wood in air containing 21% of oxygen and 79% of nitrogen is the following equation:



When oxygen is not supplied in sufficient quantity, CO is also produced in lieu and place of CO₂. Also, water vapor is engaged in the so-called water-gas shift reaction that produces hydrogen as a reaction between carbon dioxide and water vapor according to equation 2 below:



Consequently, we have a mixture of CO, H₂O, H₂, CH₄, CO₂ and N₂ from the gasification of biomass. There is also a need to measure RH in the synthesis gas, because a high-water vapor content in synthesis gas would make it difficult to burn in a combustion engine or at the flaring port.

RH percentage will be calculated with the Arduino Uno 3 board as microcontroller programmed under Arduino 2.2.1 Integrated Development Environment (IDE).

3. Results and discussion

3.1 Calibration of the RH sensors

Calibration of RH sensors mainly consist in the adjustment of the in order to get the same value on the LCD display and a reference humidity meter.

Depending on the assembly, the output oscillates according to the charge-discharge of the capacitor. The capacitor charges during the time:

$$t_1 = 0.693 * (R_4 + R_2) * C \text{ Eq. 6}$$

F_{out} is measured with Arduino and the RH is deduced.

The total oscillation period is

$$T = t_1 + t_2 = 0.693 * (R_4 + 2R_2) * C \text{ Eq. 7}$$

The oscillation frequency is

$$f = \frac{1}{T} = \frac{1.44}{(R_4 + 2R_2) * C} \text{ Eq. 8}$$

For $R_4 = 49.9 \text{ k}\Omega$ we get:

$$t_1 = 0.693 * (R_4 + R_2) * C \text{ Eq. 9}$$

and $R_3 = 576 \text{ k}\Omega$.

Witha humidity of 17% we obtained the following oscillation shown on Figure 7 below:

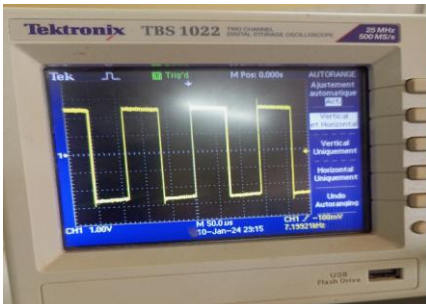

Figure 7 : Frequency function of RH test

According to the calibration curve:

$$C \in [162 \text{ pF}; 200 \text{ pF}] \text{ Eq. 10}$$

Thus:

$$f \in [7,00321 \text{ kHz}; 8,6413 \text{ kHz}] \text{ Eq. 11}$$

According to the oscillation obtained:

$$f = 7,1992 \text{ kHz} \text{ Eq. 12}$$

which confirms the accuracy of our measurement up to a few uncertainties (parasitic capacitances, precision of the oscilloscope). By measuring the frequency $f = 1/T$, we then calculate

$$C = \frac{1.44 * T}{R_4 + 2R_2} \text{ Eq. 13}$$

Let us then calculate the general equation (sensor-conditioner). We Have:

$$Rh = 496.23 * (C/C_{55}) - 443.26 \text{ Eq. 14}$$

And:

$$\frac{C}{C_{55}} = \frac{1.44 * T}{(R_4 + 2R_2) * C_{55}} \text{ Eq. 15}$$

Therefore:

$$Rh = 496,23 * \left(\frac{1.44 * T}{(R_4 + 2R_2) * C_{55}} \right) - 443,26 \text{ Eq. 16}$$

In the past, RH was determined with mechanical methods. Those methods were not very reliable and corrections had to be made to accurately read water content in the air. Humidity sensors with linear, quick and reversible responses were developed for measuring water vapor concentration in air [29]. Nowadays hygrometers are the most used and common method because these are small and reliable. The method we used here to determine the RH falls in the category of hygrometer and digital reading of RH eliminates reading errors from the user.

3.2 Electronic prototype

The prototype we have built is shown in Figure 8 below. The bottle is the gas sampling box with the relative humidity sensor affixed at the top of the blue cap and sensor legs passing through the blue cap. Only a small quantity of the gas is taken through a flexible pipe as shown on label in Figure 8 below. The board is powered with a 9V battery.



Figure 8 : Prototype with sampling box

RH sensor was glued to the cap in that way that it can be removed with the cap simply by unscrewing the cap as seen on Figure 9 below.

Comment [U17]: provide a description of the image components



Figure 9 : Sampling box and RS1101 inside the blue cap

3.3 Results obtained

3.3.1 Calibration of the RH sensor

Code related to the temperature and RH sensors are given below. Comments in the code begin with two slashes (//) and explain what is done.

```
#include<LiquidCrystal.h>
#include<Wire.h>
#include<TimeLib.h> // RTC
#include<FreqCount.h> // Calculate frequency for relative humidity
LiquidCrystal lcd(12,8,13,4,3,2); // Declare LCD display pins
float Tom = 0.0; // Time of measure
int thermoD0 = 7; // D0 to pin 7
int thermoCS = A5; // CS to A5.
int thermoCLK = 6; // Clock to pin 6
float temperature = 0.0; // Define temperature
MAX6675 thermocouple(thermoCLK, thermoCS, thermoD0);
int vccPin = 3;
int gndPin = 2;
```

After we have defined these variables, we set values of the main program as follow:

```
void setup(){
  Serial.begin(9600); // Speed of the
  // Serial port, including USB
  FreqCount.begin(1000); // Initialise frequency counter
  // Max 6675 setup: use Arduino pins
  pinMode(vccPin, OUTPUT); digitalWrite(vccPin, HIGH);
  pinMode(gndPin, OUTPUT); digitalWrite(gndPin, LOW);
  // End setup for Max 6675
} ; // End setup

Below is the code of the main loop that repeatedly measure temperature and
relative humidity.
void loop()
{
  temperature = thermocouple.readCelsius()+273.15;
  tempCels = temperature - 273.15; // Revenir aux degres Celsius
  lcd.clear(); // Clear LCD to avoid weird caracteres display
  // Calcul humidite relative
  if(FreqCount.available())
  {
    count = FreqCount.read();
    Rhum = 3.38*((1.44/count)/((R4+(2*R22))*C_55 ));
```

```

//Adjustmentdone with 3.38 as //multiplier to have 10% according //to local
weatherand reference //humidity meter
    };
//Dispaly temperature in Celcius
lcd.setCursor(0,0);
lcd.print("T ");
lcd.print(temperature-273.15,1); //Display Reactor temperature in °C with 1
decimal
lcd.print((char)223);
lcd.print("C or ");
lcd.setCursor(12,0);
lcd.print(temperature,1); //Display Reactor temperature in K with 1 decimal
lcd.print(" K");
//Display what is the time elapsed?
lcd.setCursor(0,2);
lcd.print("Meas. time ");
unsignedlong currentMillis = millis();
Tom = ((currentMillis/1000)/60.0);
//Must be 60.0 to have decimal, else
//Tom will remain an entiger
lcd.setCursor(11,2);
lcd.print(Tom,1); //Display time of //measure in minutes with 1 decimal
lcd.print(" min");
// End displays on LCD
//PLX-DAQ execution
Serial.print("DATA,"); //Annonce l'affichage des données
Serial.print(day()); //Save day
Serial.print(" "); //Shift column
Serial.print(month()); //Save month
Serial.print(" "); //Shift columnSerial.print(year()); //Save year
Serial.print(","); //Shift column
//Save date + colonne A1
Serial.print(hour()); //Save hourSerial.print("h");
Serial.print(","); //Affichage heure + une colonne B2
Serial.print(Tom,1); Serial.print(","); //Affichage minutes + une colonne B3
Serial.print(tempCels,1); Serial.print(","); //Affichage de la temperature +
colone D4
...
Serial.print(Rhum,1);
Serial.print(","); //Affichage Humidite relative + Espace d'une colonne I9
delay(6000); //Delay 6 seconds
}; //End loop.

```

The results are displayed on Figure 10 below. This RH sensor is part of the monitoring system we have built for our gasifiers. This is why there are several other parameters displayed on the LCD screen as temperature, Oxygen percentage, etc.

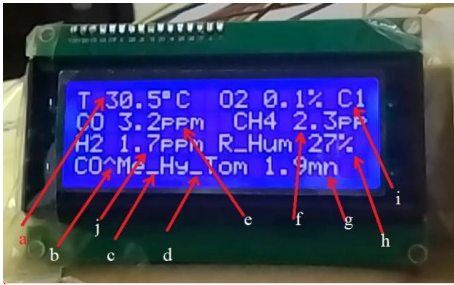

Figure 10 : Measured values display labels

Labels on the LCD display that concern us in this paper are the two following:

a = Temperature in °C,

h =relative humidity in percentage

3.3.3 Saving data in an Excel sheet

PLX-DAQ is a registered trademark of the Parallax Company. They offer it for download. There is an Arduino program that could be downloaded and adapted according to one's need.

Major features of the PLX-DAQ include the ability to record up to 26 columns of data, read or write any cell on a spreadsheet, support for throughputs up to 128000 baud and support for COM ports 1 to 15. Its basic commands sent through a simple serialport that we used and want to recall are the followings:

- LABEL: Set labels for the topmost row of the Excel sheet.
- DATA: This is the most basic and crucial command of the PLX-DAQ. It is used to send data from Arduino to Excel and print it on the Excel sheet.

Readers interested could search“PLX-DAQ” with Google and they will find all information. After we interfaced it with our program, we obtained results given in Figure 11below.

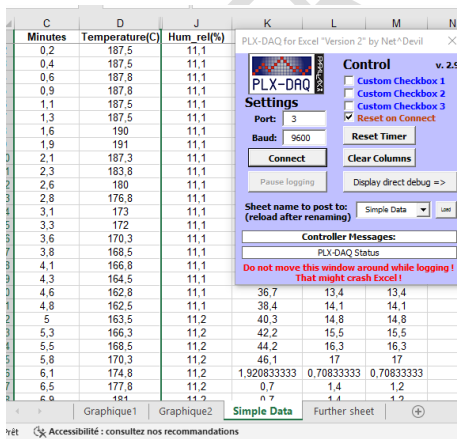

Figure 11 : Data saved on an Excel sheet

4 Conclusion

Using the Arduino board for measuring temperature relative humidity in the synthesis, we achieved a simple a reliable method of measuring the RH. With a digital display,

Comment [U18]: Image description is incomplete

measurement precision only depends on the sensitivity of the sensor. RH sensor used here have a 5% accuracy at room temperature. Temperature is measured with $\pm 1.5^{\circ}\text{C}$. The RH module same can be used to measure relative humidity in the gasification air. As a perspective, we see the possibility of coupling humidity sensors to Peltier effect cooling modules, in order to capture the water contained in the air and control the power supply of these modules according to the relative humidity at the entrance and exit of the dehumidifier.

5. REFERENCES

- 1 WAEMU, Energy policies component of the IFDD. Access to Sustainable Energy program, Key figures on energy in Burkina Faso and in the WAEMU area, Report. French; 2019.
- 2 Ministry of Energy in Burkina Faso, Energy Strategy 2019-2023; Report, 2018;58. French
- 3 Dabat MH, Hanff E, Blin J. Biofuels, an opportunity to reduce poverty in Burkina Faso, 3rd days of research in social sciences. 2009;15. French.
- 4 Ministry of Mines and Energy of Burkina Faso, Project to harness renewable energies as part of pre-electrification to support rural development. 1999;5. French.
- 5 Sustainable Energy for All, [Burkina Faso]: Rapid assessment and gap analysis, pp. 1-2, https://www.seforall.org/sites/default/files/Burkina_Faso_RAGA_FR_Released.pdf, Accessed 26 September 2023. French.
- 6 Nzihou Jean Fidele, Kouliadiati Jean, Segda B. Gérard. Potential and Feasibility of Solid Municipal Waste Treatment with Gasifiers in a Developing Country: A Review for Burkina Faso. *British Journal of Applied Science & Technology* 4(3): 450-464, 2014. Sciencedomain international www.sciencedomain.org
- 7 Fanta BARRY. "Evaluation of the conditions for developing an agricultural biomass gasification sector in Burkina Faso". PhD dissertation. International Institute of Water and Environmental Engineering Burkina Faso and University of Liège/Gembloux Agro-Bio Tech, Ouagadougou and Gembloux, Belgium. 200 pages, 2023. French.
- 8 Ahmed L. S, Characterization of the performance of a pilot biomass gasification unit, technical, economic and environmental feasibility analysis for use by an artisan in an agri-food sector in Burkina Faso; Memory; 2iE, 65 pages, 2013. French
- 9 Nzihou Jean Fidèle, Hamidou Salou, Imbga Kossi, Segda Bila Gerard, Ouattara Frederic, Tientore Hamadou, Electrical Power Generation from Heat Recovered at the throat of a Downdraft Biomass Gasifier, *American Journal of Science, Engineering and Technology*, 2023; 8(3): 133-140, <http://www.sciencepublishinggroup.com/j/ajsetdoi:10.11648/j.ajset.20230803.12>, ISSN: 2578-8345 (Print); ISSN: 2578-8353 (Online)
- 10 Nzihou Jean Fidele, Hamidou Salou, Segda Bila Gerard, Ouattara Frederic and Compaore Hamidou, Effects of a Cyclone Dimensions on Quality of Syngas Produced with a Wood-fired Biomass Gasifier, *Journal of Energy Research and Reviews*, Article number JENRR.107030, ISSN: 2581-8368, Volume 15, Issue 3, Page 1-14, 2023
- 11 Reed TB, Das A, Handbook of Biomass Downdraft Gasifier Engine Systems, Solar Energy Research Institute; 1950.
Available: <https://www.nrel.gov/docs/legosti/old/3022.pdf>, accessed 15 September 2023

12 P. E. Akhator, A. I. Obonor² and E. G. Sadjere, Design and development of a small-scale biomass entrained draft gasifier, Nigerian Journal of Technology (NIJOTECH) Vol. 38, No. 4, October 2019, pp. 922 – 930 Print ISSN: 0331-8443, Electronic ISSN: 2467-8821 <http://dx.doi.org/10.4314/njt.v38i4.15>

13 H. S. Mukunda, S. Dasappa, P. J. Paul, N. K. S. Rajan, and U. Shrinivasa, “Gasifiers and combustors for biomass - technology and field studies,” Energy for Sustainable Development, vol. 1, no. 3, pp. 27-38, 1994.

14 Abubakar A. Bukar, M. Ben Oumarou, Babagana M. Tela, Abubakar M. Eljummah Assessment of Biomass Gasification: A Review of Basic Design Considerations, American Journal of Energy Research, 2019, Vol. 7, No. 1, 1-14.

15 M. A. Chawdhury and K. Mahkamov. Development of a Small Downdraft Biomass Gasifier for Developing Countries. JOURNAL OF SCIENTIFIC RESEARCH J. Sci. Res. 3 (1), 51-64 (2011) www.banglajol.info/index.php/JSR

16 Dillip Kumar Mohanty, Abhijit Padhiary. Effect of moisture in gasification of biomass using entrained flow gasifier at constant equivalence ratio. International Journal of Industrial and Systems Engineering, 2018 Vol.28 No.3, pp.289-299. DOI: 10.1504/IJISE.2018.089740 <https://www.inderscience.com/filter.php?aid=89740>

17 Rizqi Fitri Naryanto, Hiroshi Enomoto, Anh Vo Cong, Kazuki Fukadu, Zheng Zong, Mera Kartika Delimayanti, Chuntima Chunti and Reiji Noda. The Effect of Moisture Content on the Tar Characteristic of Wood Pellet Feedstock in a Downdraft Gasifier. Applied Science 2020, 10(8), 2760; <https://doi.org/10.3390/app10082760>

18 Ingrid Lopes Motta, Nahieh Toscano Miranda, Rubens Maciel Filho, Maria Regina Wolf Maciel, Biomass gasification in fluidized beds: A review of biomass moisture content and operating pressure effects, Renewable and Sustainable Energy Reviews, Volume 94, 2018, Pages 998-1023, ISSN 1364-0321, <https://doi.org/10.1016/j.rser.2018.06.042>.

19 Jun Dong, Yong Chi, Yuanjun Tang, Mingjiang Ni, Ange Nzihou, et al.. Effect of Operating Parameters and Moisture Content on Municipal Solid Waste Pyrolysis and Gasification. Energy & Fuels, 2016, 30(5), pp.3994-4001. <https://doi.org/10.1021/acs.energyfuels.6b00042>.

20 C. Dejtrakulwong, S. Patumsawad, Four Zones Modeling of the Downdraft Biomass Gasification Process: Effects of Moisture Content and Air to Fuel Ratio, Energy Procedia, Volume 52, 2014, Pages 142-149, ISSN 1876-6102, <https://doi.org/10.1016/j.egypro.2014.07.064>.

21 Bogdan Mihai, How to use the DHT22 sensor for measuring temperature and humidity with the Arduino board, Acta Universitatis Cibiniensis – Technical series Vol. Lxviii 201, doi: 10.1515/aucts-2016-0005

22 Huan Hui Yan, Yusnita Rahayu, Design and Development of Gas Leakage Monitoring System using Arduino and ZigBee, Proceeding of International Conference on Electrical

Engineering, Computer Science and Informatics (EECSI 2014), Yogyakarta, Indonesia, 20-21 August 2014

23 L Dewi and Y Somantri, Wireless sensor network on LPG gas leak detection and automatic gas regulator system using Arduino, IOP Conf. Serie: Material Sciences Engineering, 384 012064, 2018

24 Humirel, Relative humidity sensor technical data hs1100-hs1101, <https://datasheetspdf.com/PDF/172182/Humirel/HS1101/1>. Accessed 20 october 2023

25 Sensors in industrial instrumentation G. Asch et al. 7th edition, DUNOD 2006,2010. French.

26 De la pierre G., Capacitive polymer-based hygrometer. Measurement Regulation and Automation N°11, 1981, P47. French.

27 Wiederhold P. R “Humidity measurements“. Instrumentation Technology, June and August 1975. French.

28 Analog Devices, MAX6675 Cold-Junction-Compensated K-Thermocouple-to-Digital Converter (0°C to +1024°C) <https://www.analog.com/media/en/technical-documentation/data-sheets/max6675.pdf> Accessed 29 September 2023

29 Katrin Rübner, D. Balköse and E. Robens, Methods of humidity determinationPart I: Hygrometry, Journal of Thermal Analysis and Calorimetry, Vol. 94 (2008) 3, 669–673