

# The Role Of Organizational Commitment In Mediating Employee Work Behavior As Organizational Culture In The ATVI Environment

## ABSTRACT

This research aims to determine whether Organizational Commitment plays a role in mediating the influence of Organizational Culture and Work Environment on Organizational Citizenship Behavior at the Indonesian Television Academy. This research was conducted at the Indonesian Television Academy. The sampling technique used in this research is a saturated sampling technique, because the number of samples in this research is the entire population of Indonesian Television Academy employees. The data analysis method used is multiple linear analysis. The results of this research are that there is an influence of Organizational Culture on Organizational Commitment, there is an influence of the Work Environment on Organizational Commitment, there is an influence of Organizational Commitment on Organizational Citizenship Behavior. Organizational Commitment mediates the influence of Organizational Culture on Organizational Citizenship Behavior and Organizational Commitment mediates the influence of the Work Environment on Organizational Citizenship Behavior.

### Keywords.

Organisational ; Culture; Employee; Behavior ; Environment.

## INTRODUCTION

The background of this research is based on the importance of Organizational Citizenship Behavior (OCB) for the success of an organization. OCB is voluntary behaviour undertaken by employees outside of their main duties, which contributes to organizational effectiveness and efficiency. Employees who have good OCB with extra-role behaviour can help create a positive and productive work environment, and can improve overall organizational performance (Tecoalu, 2019). However, to encourage employees to do OCB, supporting factors such as organizational culture and a conducive work environment are needed. In addition, the factor of organizational commitment also plays an important role in encouraging employees to do OCB. Organizational commitment refers to the level of trust, loyalty, and employee identification with the organization where they work. This research was conducted at the Indonesian Television Academy with the aim of identifying the role of organizational commitment as a mediator between the influence of organizational culture and work environment on OCB. By knowing the factors that influence OCB and how organizational commitment mediates the relationship between organizational culture, work environment, and OCB, companies can improve employee and organizational performance as a whole.

The Questions raised when conducting the research: Does organizational culture affect OCB?; Does the work environment affect OCB?; Does organizational commitment affect OCB?; Does organizational commitment mediate the influence of organizational culture and work environment on OCB?

The purpose of this study was to examine the influence of organizational culture and work environment on Organizational Citizenship Behaviour (OCB) at AkademiTelevisi Indonesia, as well as to examine the role of organizational commitment as a mediator in this relationship. The benefits of this research include: Increasing the understanding of the factors that influence OCB in academic and creative industry environments, particularly at AkademiTelevisi Indonesia; Provide recommendations for the management of AkademiTelevisi Indonesia in improving employee performance through the establishment of a conducive organizational culture and an adequate work environment, as well as by

building strong organizational commitment among employees; Providing contributions to science and research, especially in the field of organizational behaviour, especially related to OCB and the factors that influence it; Provide suggestions for researchers or academics who are interested in conducting further research in the same or related fields.

Thus, this research is expected to provide benefits to AkademiTelevisi Indonesia, employee organization and management, science, and researchers or academics who are interested in the topic of OCB, organizational commitment, organizational culture, and work environment. The following is a conceptual framework from the research "The Role of Organizational Commitment in Mediating the Influence of Organizational Culture and Work Environment on Organizational Citizenship Behavior at AkademiTelevisi Indonesia":

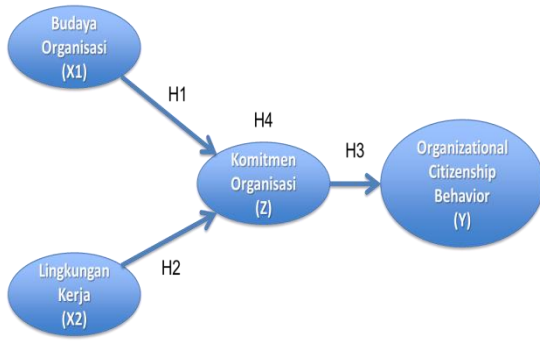

**Chart 1. Organizational Citizenship Behavior**

## LITERATURE REVIEW

The influence between organisational culture, work environment, organisational commitment, and organisational citizenship behaviour. There is a close relationship between organizational culture, work environment, organizational commitment, and Organizational Citizenship Behaviour (OCB). The following is a literature review regarding this relationship: Organizational Culture and OCB; Organizational culture can affect OCB because organizational culture reflects the values and norms adopted by the organization (Denison, 1990). Empirical studies show that organizations with strong and positive cultures have higher levels of OCB (Podsakoff et al., 2000). Work Environment and OCB; A conducive work environment can motivate employees to involve themselves in OCB. According to a study conducted by Liao and Chuang (2007), a work environment that supports innovation can increase employee motivation to perform more creative OCB. Organizational Commitment and OCB; Organizational commitment can also affect OCB because employees who have a high commitment to the organization tend to be more motivated to do OCB. Studies show that employees who have a high level of commitment to the organization have higher levels of OCB (Organ & Ryan, 1995). Mediation of Organizational Commitment in the Relationship between Organizational Culture, Work Environment, and OCB; Several studies have shown that organizational commitment can mediate the relationship between organizational culture, work environment, and OCB. For example, a study conducted by Chiaburu and Harrison (2008) found that organizational commitment mediates the relationship between innovation culture and OCB. Another study by Chen and Francesco (2000) found that organizational commitment mediates the relationship between organizational support and OCB.

### Independent Variables

Organisational Culture (X1): These are the shared values, norms and beliefs shared by employees at AkademiTelevisi Indonesia, Work Environment (X2): These are the physical and social factors that affect the performance of employees at AkademiTelevisi Indonesia.

### Mediator Variable.

Organisational Commitment (Z): These are the desire of employees to remain in the organization and fight for organizational goals. Dependent Variables: Organisational Citizenship Behaviour – OCB (Y): This is the voluntary behavior carried out by employees outside of their main duties, which contributes to organizational effectiveness and efficiency at AkademiTelevisi Indonesia.

Within this conceptual framework, it is assumed that organizational culture and work environment have a direct influence on the OCB of employees at AkademiTelevisi Indonesia. However, this influence will be mediated by organizational commitment, which refers to the level of trust, loyalty, and employee identification with the organization where they work. Therefore, this study will examine whether organizational commitment acts as a mediator between the influence of organizational culture and work environment on OCB at AkademiTelevisiIndonesia.

Within this conceptual framework, there is a relationship between the independent variables (organizational culture and work environment), mediating variables (organizational commitment), and the dependent variable (OCB). This relationship will be tested through data analysis using appropriate statistical techniques. It is hoped that the research results can provide an overview of the influence and role of variables in the relationship between organizational culture, work environment, organizational commitment, and OCB at the AkademiTelevisi Indonesia.

### **Organisational Culture**

The definition of organisational culture according to Schein (2010) is a set of values, beliefs, norms, and behaviours that are applied together within an organisation. Schein also emphasized that organisational culture is a product of the interaction between members of the organisation and the organisational environment. According to Cameron and Quinn (2011), organisational culture is a fundamental pattern of behaviour and ways of thinking that are rooted in the organisation and shape the way the organisation interacts with its environment. Cameron and Quinn developed a competitive values framework (CVF) to understand the different types of organisational culture that might exist. Hofstede (1991) defines organisational culture as a set of shared knowledge held by groups and which differentiates groups from others, whereby organisational culture can be measured and compared internationally by identifying cultural dimensions such as individualism/collectivism, clarity of rules, and power distance.

### **Organisational Commitment.**

According to Meyer and Allen (1991), organizational commitment is the degree to which individuals are bound and involved in organizations and maintain their membership in the long term. Organizational commitment consists of three dimensions, namely affective, normative, and continuous commitment. Mowday, Steers, and Porter (1979) define organizational commitment as an individual attitude toward the organization, which describes the desire to maintain membership in the organization. Mathieu and Zajac (1990) explain that organizational commitment is an individual's willingness to give energy, time, and attention to the organization it represents. Robbins and Judge (2019) explain that organizational commitment includes an individual's feelings of attachment to the organization, the desire to maintain membership, and the belief that the organization treats individuals fairly and fairly. Porter, Steers, Mowday, and Boulian (1974) define organizational commitment as the level of a person's desire to maintain a relationship with an organization, as well as the beliefs and values that individuals hold about the organization.

### **Organisational Citizenship Behaviour**

Organizational Citizenship Behaviour (OCB) is voluntary behaviour performed by employees outside of their formal duties to improve overall organizational performance (Organ, 1988). Podsakoff, MacKenzie, Paine, and Bachrach (2000) describe OCB as voluntary behaviour performed by employees to help the organization achieve its goals, which are not included in the formal duties of employees. Organ (1990) adds that OCB includes employee behaviour that goes beyond the formal duties expected of their jobs, including helping co-workers, complying with organizational rules and procedures, and providing constructive suggestions and criticism. Robinson, Kraatz, and Rousseau (1994) stated that OCB includes voluntary actions that employees take to support the organization, regardless of whether the behaviour is directly related to their job duties. Siqueira (2013) explained that OCB involves employee behaviour directed at improving organizational performance and job satisfaction, such as helping co-workers, maintaining a clean and tidy work environment, and showing polite and friendly behaviour.

## **RESEARCH METHODS**

This type of research is a quantitative study with a cross-sectional design. Quantitative research is carried out using numbers and statistics to analyse data obtained from respondents through

questionnaires or surveys. Quantitative research is very suitable for measuring the variables involved in this research, such as organisational culture, work environment, organisational commitment, and OCB.

The cross-sectional design is carried out by taking data at a certain time and collecting data from a randomly represented sample of the population. This design is suitable for use in this study because the aim is to examine the relationship between these variables at a certain time and in the same organisation, namely AkademiTelevisi Indonesia. In this study, respondents were asked to fill out a questionnaire that measured variables related to this research, such as organizational culture, work environment, organizational commitment, and OCB. The data will be analysed using statistical analysis techniques such as regression and mediation analysis to examine the influence between these variables. The population in this study were all 30 employees working AkademiTelevisi Indonesia who had at least one year of work experience, namely by the census method.

### **In this study, the data collection methods used are as follows.**

**Questionnaire:** Researchers can use questionnaires to collect data from respondents. Questionnaires can contain questions related to organisational culture, work environment, organisational commitment, and organisational citizenship behaviour. Questionnaires can be distributed online or offline to predetermined respondents. **Interview:** Researchers can conduct interviews with AkademiTelevisi Indonesia employees to obtain more in-depth information related to the research topic. Interviews can be conducted face-to-face or online via a video conferencing application. **Observation:** Researchers can make direct observations in AkademiTelevisi Indonesia's work environment to see how employees interact with each other and how organizational culture is applied in the workplace.

### **Documentation.**

Researchers can collect data from documents related to organisational culture, work environment, and organisational commitment, such as company policies, financial reports, and other documents. In using these data collection techniques, researchers can choose the most appropriate technique and can provide valid and reliable results.

In this study, data analysis techniques that can be used are as follows: **Descriptive analysis:** This technique can be used to provide an overview of the characteristics of the respondent, such as age, gender, length of work, and level of education. In addition, this technique can also be used to describe other data, such as frequency, mean, median, and mode. **Multiple linear regression analysis:** This technique can be used to determine the effect of organizational culture and work environment variables on organizational commitment and organizational citizenship behaviour. In addition, this technique can also be used to test the hypothesis related to the mediating variable, namely organizational commitment.

### **Mediation analysis.**

This technique can be used to test whether organizational commitment variables mediate the influence between organizational culture and work environment variables on organizational citizenship behaviour. This technique can be used using multiple linear regression methods using the Sobel test or bootstrapping to test the significance of mediation. **Factor analysis:** This technique can be used to identify organizational culture and work environment factors that influence organizational commitment and organizational citizenship behaviour. This technique can be performed using exploratory factor analysis (EFA) or confirmatory factor analysis (CFA) using special software such as SPSS, AMOS, or Lisrel. In using these data analysis techniques, researchers can choose the technique that best suits the data that has been collected and the research objectives. It is important to ensure that the data analysis techniques used can provide valid and reliable results and can answer the problem formulation and research objectives.

### **Hypothesis**

H1: The Work Environment does not affect the ATVI employees Organisational Commitment. Based on the results from Table 4, the P values for Work environment -> Organisational commitment is 0.371 which is  $> 0.05$ , proving the null hypothesis to be accepted. T values linking Work environment to Organisational commitment (Figure 3) is 0.895 which is also  $< 2$  showing further proof that these 2 variables are unrelated according to the results obtained from employees working in AkademiTelevisi Indonesia. However, according to other research articles (Ferry Irawan & Mei le ,2021), It argues that Work Environment does have a positive and significant effect on Organisational Commitment with T-Value

4.934 and P-Value 0.000. This research had AVE for both Work Environment and Organisational Commitment at 0.947 and 0.953 respectively and Composite reliability for each variable all > 0.9. Since the results produced by (Ferry Irawan & Mei le, 2021) had a higher AVE and Composite reliability score, this proves that their results were more reliable. This could be due to a number of factors, namely the population size and the indicators chosen for each variable.

H2: Organisational Culture has some positive effect on ATVI employees. Organisational Commitment According to the results in Table 4, the P values for the Organisational Culture -> Organisational commitment is 0.018 which is < 0.05, showing that the 2nd hypothesis is true. The T values (Figure 3) further support the 2nd hypothesis scoring 2.363 which is > 2, showing that both these variables have a strong tendency among one another. This also shows that ATVI employee's higher order needs are being satisfied which would lead to higher level of commitment among employees. Whereas firms that implement coercive authority affects the level of commitment negatively (Singh & Das, 1978). Other research articles from (Jufrizen & Azila, 2023) further support the findings that Organisational Culture does positively affect Organisational Commitment with T-Value and P-Values 2.025 and 0.043 respectively. The research had AVE for Organisational Culture and Commitment at 0.680 and 0.821 respectively, and composite reliability above 0.9 for all variables. Their findings are therefore slightly more reliable than that of ours, however, their results still agree with our hypothesis.

H3: Organisational Commitment has some positive effect on ATVI employees Organisational citizenship behaviour. Based on the results from Table 4, the P values for the Organisational Commitment -> Organisational citizenship behaviour is 0.000 which is < 0.05, proving that the 3rd hypothesis is true as well. The T values (Figure 3) for the 2 variables score 6.843 which is > 2 which further solidifies the statement. Employees committed to their firm would perform and help other employees in further developing the firm. This statement is also backed up by (Lepine et al. 2002) and (O'Reilly and Chatman 1986) who states that organizational commitment is one of the important factors that strengthens organisational citizenship behaviour and organisational commitment is positively associated with organisational citizenship behaviour respectively. Several research from (Jufrizen & Azila, 2023), (Tuti Setyorini, JanriDelastrianiManafe, and Indawati Jauhar Nino, 2022) and (Sova Arviah & Sigmin Johaness Lo, 2020) strongly support the findings. The results which agrees with our hypothesis the most was from (Sova Arviah & Sigmin Johaness Lo, 2020) with T-Value and P-Values 9.718 and 0.000 respectively.

H4: Organisational Commitment mediates the effects of Work Environment and Organisational Culture on Organisational Citizenship behaviour. According to Table 5, the T-Values and P-Values relating Work Environment -> Organisational Commitment -> Organisational Citizenship Behaviour scored 0,766 which is < 2 and 0.444 which is > 0.05 respectively. Furthermore, the T Values and P Values relating Organisational Culture -> Organisational Commitment -> Organisational Citizenship Behaviour scored 1.942 which is just below < 2 and 0.052 which is just above > 0.05 respectively. These results shows that the 4th hypothesis cannot be accepted. However, according to research from (Sova Arviah & Sigmin Johaness Lo, 2020) and (Jufrizen & Azila, 2023), their findings argue that Organisational Commitment is able to mediate the effects of Work Environment and Organisational Culture on OCB. Results supporting Organisational Commitments ability to mediate Organisational Culture on OCB show T-Values and P-Values 2.153 and 0.043 respectively.

While findings arguing that Organisational Commitment does mediate the effects of Work Environment on OCB show T-Values and P-Values 3.022 and 0.003 respectively. The results may differ from other articles due to a larger population and sample size which could affect the reliability and the results of the research.

## RESULTS AND DISCUSSION

By (Hair Jr et al., 2016), there are several stages in conducting analysis using SEM PLS, namely model specification testing (inner and outer model), reliability and validity testing, and structural model evaluation.

For each variable, we have used several indicators in this research. The measurement of Work Environment was measured using 5 indicators (LK1,LK2,LK3,LK4,LK5), Organisational Culture was measured using 4 indicators (BO1,BO2,BO3,BO4), Organisational Commitment was measured using 9 indicators (CC1, CC2, CC3, EC1, EC2, EC3, NC1, NC2, NC3) and finally Organisational Citizenship Behaviour was measured using 16 indicators as seen in (Figure 1).

## A. Convergent and Divergent Validity Test

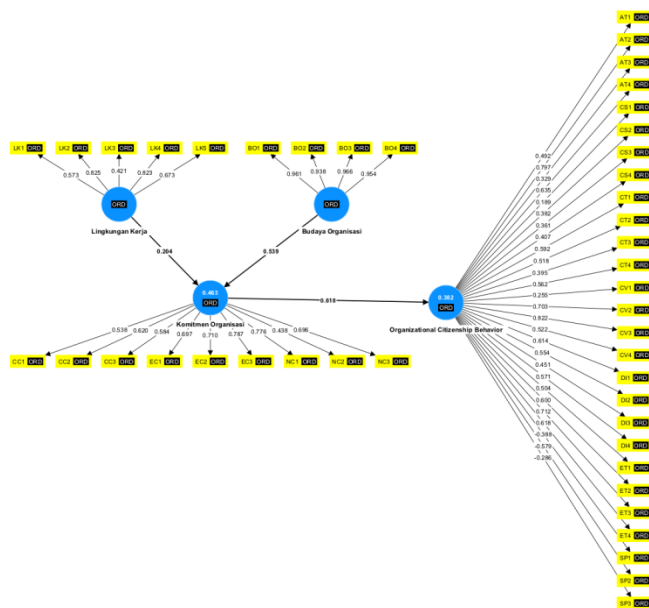

Source: Smart PLS data processing result

**Figure 1: Loading Factor Value**

For each variable, we have used several indicators in this research. The measurement of Work Environment was measured using 5 indicators (LK1,LK2,LK3,LK4,LK5), Organisational Culture was measured using 4 indicators (BO1,BO2,BO3,BO4), Organisational Commitment was measured using 9 indicators (CC1, CC2, CC3, EC1, EC2, EC3, NC1, NC2, NC3) and finally Organisational Citizenship Behaviour was measured using 16 indicators as seen in (Figure 1).

Based on the results of the convergent and divergent validity test obtained (Figure 1). We can conclude that each indicator with a value above 0.5 is valid.

Construct	Indicators	Loading Factors	Valid/Invalid
Work Environment	LK1	0,573	VALID
	LK2	0,825	VALID
	LK3	0,421	INVALID
	LK4	0,823	VALID
	LK5	0,673	VALID
Organisational Culture	BO1	0,961	VALID
	BO2	0,938	VALID
	BO3	0,966	VALID
	BO4	0,954	VALID
Organisational Commitment	CC1	0,538	VALID
	CC2	0,62	VALID
	CC3	0,584	VALID
	EC1	0,697	VALID
	EC2	0,71	VALID
	EC3	0,787	VALID
	NC1	0,776	VALID
	NC2	0,438	INVALID
	NC3	0,696	VALID
Organisational Citizenship Behaviour	AT1	0,492	INVALID
	AT2	0,797	VALID
	AT3	0,329	INVALID
	AT4	0,635	VALID
	CS1	0,189	INVALID
	CS2	0,382	INVALID
	CS3	0,361	INVALID
	CS4	0,407	INVALID
	SP1	-0,388	INVALID
	SP2	-0,579	INVALID
	SP3	-0,286	INVALID
	CT1	0,592	VALID
	CT2	0,518	VALID
	CT3	0,395	INVALID
	CT4	0,562	VALID
	CV1	0,255	INVALID
	CV2	0,703	VALID
	CV3	0,822	VALID
	CV4	0,522	VALID
	DI1	0,614	VALID
	DI2	0,554	VALID
	DI3	0,451	INVALID
	DI4	0,571	VALID
	ET1	0,504	VALID
ET2	0,6	VALID	
ET3	0,712	VALID	
ET4	0,618	VALID	

Source: SmartPLS data processing results

**Table 1: Loading Factor Values**

Thus as seen from (Table 1), Invalid indicators from each variable will be removed from the model, among them : Work Environment – 4 Indicators are seen to be valid; Organisational Culture – All 4 indicators are valid; Organisational Commitment – 8 indicators are valid; and Organisational Citizenship Behaviour – 15 Indicators are seen to be valid

Construct	Indicators	Loading Factors	Valid/Invalid
Work Environment	LK1	0,573	VALID
	LK2	0,825	VALID
	LK4	0,823	VALID
	LK5	0,673	VALID
Organisational Culture	BO1	0,961	VALID
	BO2	0,938	VALID
	BO3	0,966	VALID
	BO4	0,954	VALID
Organisational Commitment	CC1	0,538	VALID
	CC2	0,62	VALID
	CC3	0,584	VALID
	EC1	0,697	VALID
	EC2	0,71	VALID
	EC3	0,787	VALID
	NC1	0,776	VALID
	NC3	0,696	VALID
Organisational Citizenship Behaviour	AT2	0,797	VALID
	AT4	0,635	VALID
	CT1	0,592	VALID
	CT2	0,518	VALID
	CT4	0,562	VALID
	CV2	0,703	VALID
	CV3	0,822	VALID
	CV4	0,522	VALID
	DI1	0,614	VALID
	DI2	0,554	VALID
	DI4	0,571	VALID
	ET1	0,504	VALID
	ET2	0,6	VALID
	ET3	0,712	VALID
	ET4	0,618	VALID

Source: SmartPLS data processing results  
**Table 2: Updated Loading Factor Values**

	Cronbach's alpha	Composite reliability (rho_a)	Composite reliability (rho_c)	Average variance extracted (AVE)
Budaya Organisasi	0.968	0.975	0.976	0.912
Komitmen Organisasi	0.832	0.846	0.876	0.543
Lingkungan Kerja	0.723	0.777	0.838	0.637
Organizational Citizenship Behavior	0.895	0.922	0.911	0.411

Source: SmartPLS data processing results

**Table 3: Composite reliability and Average Variance Extracted (AVE)**

With this the model (Figure 2) now has all its indicators each having a loading factor > 0.5, thus it can be concluded that the indicators have high levels of validity and have met convergent validity.

### Composite Reliability Test

As seen from (Table 3), the AVE of each variable is > 0.5 except for organisational citizenship behaviour scoring 0.411 just under 0.5. Normally, we would classify the variable Organisational Citizenship to not have good discriminant validity. However since each variable scored > 0.7 for Composite Reliability, the convergent validity of the construct is still adequate enough for research (Fornell & Larcker, 1981).

### Coefficient Path Test.

(Figure 2) The paths indicate the relation between each variable with one another and their T-Values. The relation between the Work environment and Organizational Commitment scored a T-Value of 0.895, Organizational culture and Organizational Commitment score a T-Value of 2.363, and Organizational Commitment and Organizational Citizenship Behavior showed a T-Value of 6.843. T-Values larger than 2 are widely accepted showing a greater significance of the difference between group which means that it is unlikely that the relation occurred by chance alone. Thus showing that Work Environment and Source: SmartPLS data processing results Organizational Commitment don't tend to have a strong relation.

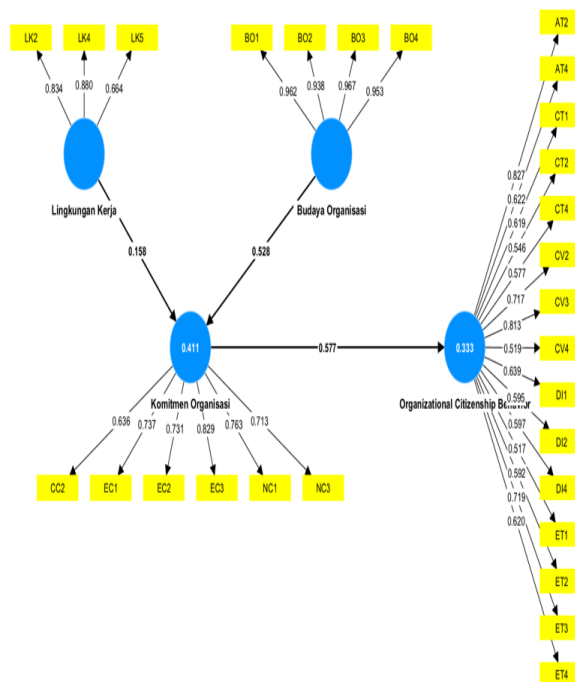

Source: SmartPLS data processing results  
**Figure 2: Updated Loading Factor Value**

**Coefficient Path Test**

(Figure 3) The paths indicate the relation between each variable with one another and their T-Values. The relation between the Work environment and Organizational Commitment scored a T-Value of 0.895, Organizational culture and Organizational Commitment score a T-Value of 2.363, and Organizational Commitment and Organizational Citizenship Behavior showed a T-Value of 6.843. T-Values larger than 2 are widely accepted showing a greater significance of the difference between group which means that it is unlikely that the relation occurred by chance alone. Thus showing that Work Environment and Organizational Commitment don't tend to have strong relation.

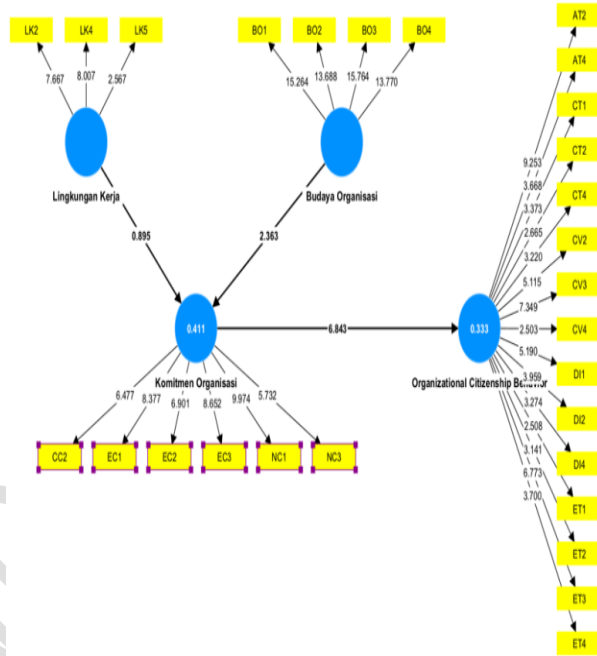

Source: SmartPLS data processing results  
**Figure 3: Bootstrapping Model**

**R-Square Test**

According to the values obtained from the R-squared test (Figure 1 and 3), it is shown that the dependent variables Organisational Commitment and Organisational Citizenship Behaviour scored R-Square values of 41.1% and 33.3% respectively. Thus, this shows that our independent variables correlates poorly-moderately well to its dependent variables.

**Hypothesis Test**

	Original sample (O)	Sample mean (M)	Standard deviation (STDEV)	T statistics (O/STDEV)	P values
Budaya Organisasi → Komitmen Organisasi	0.528	0.498	0.224	2.363	0.018
Komitmen Organisasi → Organizational Citizenship Behavior	0.577	0.657	0.084	6.843	0.000
Lingkungan Kerja → Komitmen Organisasi	0.158	0.223	0.177	0.895	0.371

Source: SmartPLS data processing results  
**Table 4: Direct Hypothesis Test Results**

	Original sample (O)	Sample mean (M)	Standard deviation (STDEV)	T statistics (O/STDEV)	P values
Lingkungan Kerja -> Komitmen Organisasi -> Organizational Citizenship Behavior	0.091	0.146	0.119	0.766	0.444
Budaya Organisasi -> Komitmen Organisasi -> Organizational Citizenship Behavior	0.305	0.329	0.157	1.942	0.052

Source: SmartPLS data processing results  
**Table 5: Indirect Hypothesis Test Results**

## CONCLUSIONS AND SUGGESTIONS

As specified by the results obtained from our research and calculations, the following conclusions can be derived: (a) **The Work Environment does not significantly affect the Organisational Commitments of ATVI employees.** The results does not support the hypothesis that work environment plays a big part in organizational commitment; (b) **Organisational Culture positively affects ATVI employees Organisational Commitment.** The results support that ATVI employees commitment is positively impacted by ATVI's Organisational Culture. Employees may feel comfortable and take a liking to how ATVI higher ups motivate and delegate their work; (c) **Organisational Commitment positively affects ATVI employees Organisational Citizenship Behaviour.** We can conclude that ATVI employees citizenship behaviour is widely connected to their organisation's culture. The employees may feel the want to help or work together as it may be how the firm would want them to do their work; (d) **Organisational Commitment does not mediate the effects of Work Environment and Organisational Culture on Organisational Citizenship behaviour.** The results do not support the hypothesis, showing that these variables do not link to each other very well. However, based on other research and articles, Organisational Commitment should mediate the effects of Organisational Commitment and Organisational Citizenship Behaviour, even though our P-Value 0.052 is just a tad over 0.05. This could be due to a relatively low population size used in this research which could have resulted in some outliers.

## REFERENCES

- Arviyah S, Lo SJ. the Mediating Impact of Organizational Commitment on the Influence of Leadership Behavior and Work Environment on Organizational Citizenship Behavior At Ajb Bumiputera 1912 Headquarter. *Dinasti International Journal of Management Science*. 2020 Nov 25;2(2):311-9.
- Chen ZX, Francesco AM. Employee demography, organizational commitment, and turnover intentions in China: do cultural differences matter?. *Human relations*. 2000 Jun;53(6):869-87.
- Chiaburu DS, Harrison DA. Do peers make the place? Conceptual synthesis and meta-analysis of coworker effects on perceptions, attitudes, OCBs, and performance. *Journal of applied psychology*. 2008 Sep;93(5):1082.
- Denison D. Corporate culture and organizational. New York: Wiley. Dike, P.(2013). The impact of workplace diversity on organizations. Dobbin, F., & Jung, J.(2010). Corporate board gender diversity and stock performance: The competence gap or institutional investor bias. *NCL Rev*. 1990;89:809.
- Fornell C, Larcker DF. Structural equation models with unobservable variables and measurement error: Algebra and statistics.
- Gruman JA, Saks AM. Performance management and employee engagement. *Human resource management review*. 2011 Jun 1;21(2):123-36.
- Hair Jr JF, Matthews LM, Matthews RL, Sarstedt M. PLS-SEM or CB-SEM: updated guidelines on which method to use. *International Journal of Multivariate Data Analysis*. 2017;1(2):107-23.
- Irawan F, le M. The effect of work environment and job satisfaction on employee organizational commitment. In 3rd Tarumanagara International Conference on the Applications of Social Sciences and Humanities (TICASH 2021) 2022 Apr 21 (pp. 1452-1457). Atlantis Press.
- Kelloway EK, Turner N, Barling J, Loughlin C. Transformational leadership and employee psychological well-being: The mediating role of employee trust in leadership. *Work & Stress*. 2012 Jan 1;26(1):39-55.
- Liao H, Chuang A. Transforming service employees and climate: a multilevel, multisource examination of transformational leadership in building long-term service relationships. *Journal of applied psychology*. 2007 Jul;92(4):1006.
- Mathieu JE, Zajac DM. A review and meta-analysis of the antecedents, correlates, and consequences of organizational commitment. *Psychological bulletin*. 1990 Sep;108(2):171.
- Meyer JP, Allen NJ. A three-component conceptualization of organizational commitment. *Human resource management review*. 1991 Mar 1;1(1):61-89.
- Mowday RT, Steers RM, Porter LW. The measurement of organizational commitment. *Journal of vocational behavior*. 1979 Apr 1;14(2):224-47.
- Noor SF, Jufrizen J. Leader-Member Exchange Terhadap Kepuasan Kerja: Mediasi Komitmen Organisasi dan Perceived Organizational Support. *Jurnal Ilmiah Manajemen dan Bisnis*. 2023 Apr 30;24(1):26-41.
- Organ DW. Organizational citizenship behavior: The good soldier syndrome. Lexington books/DC Heath and Com; 1988.
- Organ DW. Organizational citizenship behavior: The good soldier syndrome. Lexington books/DC Heath and Com; 1988.
- Podsakoff PM, MacKenzie SB, Paine JB, Bachrach DG. Organizational citizenship behaviors: A critical review of the theoretical and empirical literature and suggestions for future research. *Journal of management*. 2000 Jun;26(3):513-63.
- Priskila E, Tecoalu M, Tj HW. The Role of Employee Engagement in Mediating Perceived Organizational Support for Millennial Employee Organizational Citizenship Behavior. *Journal of Social Science*. 2021 May 27;2(3):258-65.
- Robbins SP, Judge TA, Vohra N. Organizational behaviour by Pearson 18e. Pearson Education India; 2019.
- Robinson SL, Kraatz MS, Rousseau DM. Changing obligations and the psychological contract: A longitudinal study. *Academy of management Journal*. 1994 Feb 1;37(1):137-52.
- Schein EH. Organizational culture and leadership. John Wiley & Sons; 2010 Jul 16.
- Schneider B, Brief AP, Guzzo RA. Creating a climate and culture for sustainable organizational change. *Organizational dynamics*. 1996 Mar 1;24(4):7-19.
- Setyorini T, Manafe JD, Nino IJ. The Role of Organizational Commitment and Organization Culture Toward Job Performance. *Jurnal Riset dan Aplikasi: Akuntansi dan Manajemen*. 2022 Mar 31;5(3).
- Sunaris D, Wahyoedi S, Tecoalu M. Effects of organizational commitment and organizational justice on organizational citizenship behavior with job satisfaction as a mediation. *International Journal of Science, Technology & Management*. 2022 May 18;3(3):630-40.

Tecoalu M, Tj HW, Ferdian F. The Effect of Price Perception and Brand Awareness on Service Quality Mediated by Purchasing Decisions:(Study Case on PT. Maybank Indonesia Finance Credit Products). Journal of Humanities, Social Science, Public Administration and Management (HUSOCPUMENT). 2021 Oct 31;1(4):183-95.

UNDER PEER REVIEW