

# Opinion Article

## Explicit dynamic failure analysis of a reinforced concrete beam using impact load

**Abstract:** Concrete beam is one of the common components in building structure, in the long-term use process, may be affected by various factors and damage, such as chloride ion penetration, carbonization, cracks and so on. Therefore, it is of great significance to study the failure mechanism of concrete beams. This paper analyzes the failure of a reinforced concrete beam by using the method of display dynamics simulation, analyzes its failure process, the research shows that: When the beam is subjected to load, it has a large displacement and deformation. The maximum displacement is 164.12mm; the stress distribution is uneven, and the maximum equivalent stress is about 25Mpa; after the load reaches a certain degree, the beam appears obvious cracks and failures, and the scope of failure gradually expands with the increase of the load.

**Keywords:** Reinforced concrete; explicit dynamics; failure

### 1 Introduction

Concrete beam is one of the common components in building structure, which bears the role of building's own weight and external load. In the course of long-term use, concrete beams may be damaged by various factors, such as chloride ion penetration, carbonization, cracks and so on. Therefore, it is of great significance to study the failure mechanism of concrete beam. The research of failure mechanism of concrete beam can provide scientific basis for engineering practice. Through the in-depth understanding of the failure mechanism of concrete beams, more scientific and reasonable design and construction schemes can be formulated to improve the seismic performance and durability of concrete beams. At the same time, for the concrete beam that has problems, it can also determine the repair plan and measures by understanding its failure mechanism<sup>[1]</sup>.

The research on the failure mechanism of concrete beam has a positive effect on promoting the advancement of building material mechanics. With the development of society and the advancement of science and mechanics, people have higher and higher requirements for the performance and quality of building materials. Through the research on the failure mechanism of concrete beam, the performance and characteristics of concrete materials can be deeply understood, and the scientific basis for the improvement and upgrading of concrete materials can be provided.

In addition, the research on the failure mechanism of concrete beam can also provide reference for earthquake disaster prevention and control. In the event of an earthquake, the seismic ability of a building is an important factor to ensure the safety of people's lives and property. By studying the failure mechanism of concrete beams, we can better understand the deformation and failure process of buildings under earthquake load, and provide support for improving the earthquake resistance of buildings and disaster prevention and reduction.

In the study of the failure mechanism of concrete beams, the commonly used methods include experimental research and numerical simulation. The experimental

research can observe the deformation and failure process of concrete beam through loading test, and carry out data collection and analysis. The numerical simulation is to simulate the deformation and failure process of the concrete beam under different loads through the computer program, so as to obtain its failure mechanism.

Among them, the numerical simulation technology plays an important role in the research of the failure mechanism of concrete beam. With the continuous development of computer technology, numerical simulation technology has become an indispensable tool in the mechanical analysis of concrete structures. Through numerical simulation, the internal structure and stress distribution of concrete beams can be analyzed in detail, and the deformation and failure process can be predicted. At the same time, the numerical simulation can also compare the experimental results to verify its accuracy and reliability.

In addition, many factors should be taken into account in the study of failure mechanism of concrete beams. For example, temperature, humidity, oxidation and other environmental factors will have an impact on the performance of concrete beams, and different concrete mix ratio, strength and other parameters will also have an impact on its failure mechanism. Therefore, in the study of the failure mechanism of concrete beams, it is necessary to consider the role of many factors comprehensively, and carry out systematic analysis and evaluation<sup>[2]</sup>.

In a word, the research of failure mechanism of concrete beam is of great significance. Through in-depth research and combined with engineering practice, it can promote the progress of building material technology, improve the seismic ability and durability of buildings, and provide reference for the prevention and control of earthquake disasters.

## 2 Finite element method

### 2.1 Basic idea of finite element method

Finite Element Method (FEM) is a method of solving engineering problems through numerical calculation. It converts complex physical problems into mathematical models and uses computers to solve them. The finite element method has become one of the indispensable tools in modern engineering analysis and design, widely used in the fields of structural mechanics, fluid mechanics, thermodynamics, electromagnetic field and so on.

The basic idea of finite element method is to divide a complex physical problem into many small parts, each part can be regarded as a simple geometric shape, such as line segment, triangle or quadrilateral. These small parts are called "finite elements," and each finite element can be described as a mathematical model and can be solved by a computer program.

In the finite element method, it is first necessary to establish a mathematical model, that is, according to the physical quantities and geometric shapes involved in the actual problem, to establish the corresponding equations. For example, in structural mechanics, common equations include elastic mechanics equations, material constitutive relations, etc.

Next, in the discretized model, each finite element needs to be solved. Usually, the method of numerical integration is used to calculate the physical quantity inside each finite element and transfer the data between adjacent finite elements through the boundary conditions. In the process of solving, it is necessary to control the numerical error to ensure the accuracy and stability of the calculation results.

The advantage of finite element method is not only its efficiency and accuracy, but also that it can simulate various complex physical phenomena. For example, in structural mechanics, it can be used to analyze the stress and deformation of Bridges, buildings, aircraft, automobiles and other engineering structures; In fluid mechanics, it can be used to study the motion laws of water flow, air flow, oil flow and other fluids; In thermodynamics, it can be used to calculate the temperature field, heat transfer and other problems<sup>[3]</sup>.

On the basis of the traditional finite element method, this study aims at the characteristics of reinforced concrete beams, such as the need to carefully study the stress situation and maintain the accuracy of the calculation accuracy, and adopts the local encryption method in the grid division to ensure the accuracy of the study.

## 2.2 Introduction to Ansys Explicit dynamics module

Explicit dynamics is a finite element analysis method used to simulate the dynamic response of objects in transient events such as high-speed collisions or explosions. It could help engineers and scientists better understand and predict how objects behave under extreme conditions<sup>[4]</sup>.

In explicit dynamics, objects are divided into many small units, each of which has a mass, shape, and material properties<sup>[5]</sup>. Through the numerical calculation of these elements, information such as the position, speed and acceleration of the object at different time points can be obtained.

Different from other finite element analysis methods, explicit dynamics uses an explicit time integration scheme. This means that each time step can be calculated directly without the need to solve nonlinear equations. This makes explicit dynamics ideal for handling transient events such as high-speed shocks, as it can quickly and accurately simulate the dynamic response of an object.

However, due to the explicit time integration scheme, the computational stability of explicit dynamics is limited. When the time step is too large, the simulation results may lose accuracy and even produce numerical oscillation. Therefore, when simulating with explicit dynamics, it is necessary to carefully select the time step and perform the necessary numerical stability analysis.

In addition to its use in high-speed collision and explosion simulations, explicit dynamics can also be applied to other fields, such as material processing, seismic engineering, and biomechanics. In material processing, for example, explicit dynamics can help predict the behavior of materials under conditions such as shear, tension, and compression. In earthquake engineering, explicit dynamics can be used to simulate the response of buildings and structures during an earthquake. explicit dynamics is a powerful finite element analysis method that helps scientists and engineers better understand and predict how objects behave under extreme conditions. Although its computational stability is limited, it is still a very useful tool after the correct selection of time steps and the necessary numerical stability analysis<sup>[6]</sup>.

## 2.3 ANSYS explicit dynamic analysis steps

Explicit dynamic analysis mainly includes 8 steps, specific operations are as follows:

1. Prepare the model: Create the geometric model and mesh. If needed, add material properties, boundary conditions, and loads.
2. Define material properties: In ANSYS, you can define a variety of material properties, including elastic modulus, Poisson ratio, density, and more.
3. Define boundary conditions: Define all necessary constraints and boundary conditions in the model, such as fixed support, loading position, etc.
4. Define loads: Define all loads applied to the model, such as pressure, gravity, etc.
5. Check the model: Check that all parameters of the model are set correctly. Make sure there are no errors or warning messages.
6. Perform explicit dynamics analysis: set the solver type to "Explicit Dynamics" and run the analysis. The solver will use an explicit time integration method to calculate the response for each time step.
7. Analysis results: View and analyze the results to determine whether the design requirements are met. If needed, you can adjust the model and rerun the analysis.
8. Optimization design: carry out the necessary design optimization according to the results, and repeat the above steps until the final design goal is reached.

Most nonlinear dynamics problems are usually solved by the explicit method,

especially when solving the transient highly nonlinear problems of large structures, which shows that the solution method has obvious advantages. The following is a brief comparison between implicit and explicit methods of solving dynamic problems involving numerical integration methods in the time domain. Before the mid-1980s, people basically used the Newman method to integrate the time domain. According to the Newman method, displacement, velocity<sup>[7]</sup>, and acceleration have the following relationship:

$$u(i+1)=u(i)+At*v(i)[(1-2p)a(i)+2p*a(i+1)] \quad (1)$$

$$v(i+1)=V(i)+At[(1-2q)a(i)+2qa(i+1)] \quad (2)$$

In the above formula,  $u(i+1)$  and  $u(0)$  are the displacement of the current moment and the previous moment respectively,  $v(i+1)$  and  $v(i)$  are the velocity of the current moment and the previous moment,  $a(i+1)$  and  $a(i)$  are the acceleration of the current moment and the previous moment,  $p$  is two undetermined parameters,  $t$  is the time difference between the current moment and the previous moment, and the symbol  $*$  is the multiplication sign. According to equations (1) and (2), the displacement, velocity and acceleration at any time in the Newman method are interrelated, which makes the solution of the motion equation become a series of interrelated nonlinear equations, and this solution process must be achieved by iterating and solving the simultaneous equations. This is often referred to as an implicit solution. There are two problems with implicit solutions. The iterative process does not necessarily converge, and the simultaneous equations may appear ill-conditioned and have no definite solution. The biggest advantage of implicit solution is that it has unconditional stability, that is, the time step can be arbitrarily large.

If the central difference method is used for time domain integration of dynamic problems, there are the following displacement, velocity and acceleration relations:

$$u(i+1)=2u(i)-u(i-1)+a(i)(At)^2 \quad (3)$$

$$v(i+1)=[u(i+1)-u(i-1)]/2(At) \quad (4)$$

Where  $u(i-1)$  is the displacement at time  $-1$ . It can be seen from equation (3) that the displacement at the current time is only related to the acceleration and displacement at the previous time, which means that the displacement at the current time does not need to be solved by iterative process. In addition, as long as the mass matrix and damping matrix in the process of motion are diagonalized, the acceleration of the previous moment does not need to solve the simultaneous equations, so that the problem is greatly simplified, which is the so-called explicit solution method. The advantage of the explicit solution method is that it has no convergence problem and does not need to solve simultaneous equations. Its disadvantage is that the time step is limited by the numerical integral stability and cannot exceed the critical time step of the system<sup>[7]</sup>.

### **3. Finite element modeling and damage analysis of reinforced concrete beams**

#### **3.1 Finite element Modeling**

Before the finite element simulation, the reinforced concrete beam is first modeled. As shown in Fig. 1, the steel bar inside the reinforced concrete is composed of 20 stirrups and 4 longitudinal bars. The size of the stirrups is 200mmx400mm, the thickness of the protective layer is 20mm, the radius of the stirrups is 4mm, and the radius of the longitudinal bars is 8mm. Form all the rebar into a new part, concrete and 2 supporting and impacting objects into four separate solid pieces.

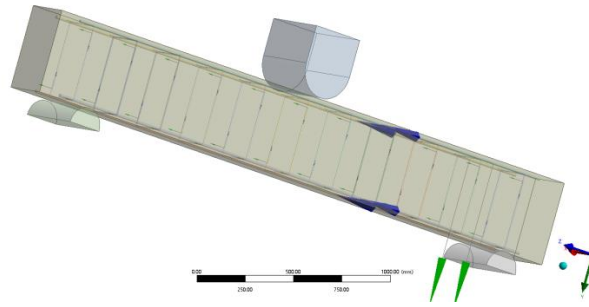

Fig.1 Reinforced concrete beam model

### 3.2 Material property Settings

Then, the concrete ingredient is set in the ingredient warehouse, the ingredient is selected as 35Mpa concrete, and the specific properties of the material are shown in Table 1.

Table 1 Material properties of 35Mpa concrete

Property	Value	Unit
Density	2314	kg m <sup>-3</sup>
Specific Heat Constant	654	J kg <sup>-1</sup> C <sup>-1</sup>
Pressure	1.67E+10	Pa
Shear Modulus		

### 3.3 Model Settings

The following is the setting of the failure simulation of reinforced concrete beams in the Model. The interface of Model is shown in Fig. 2.

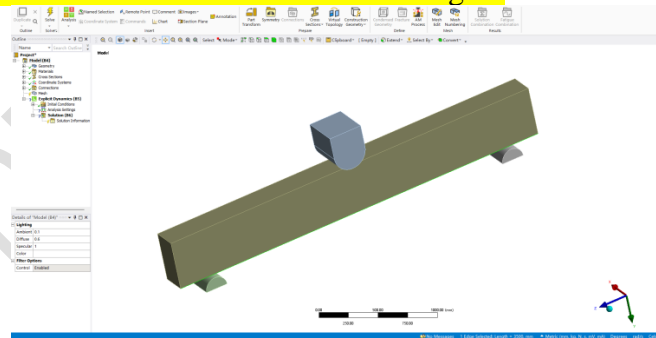

Fig.2 Model interface

The contact of the beam was set and defined in the option. It between the upper surface of the beam and the surface of the impact object was defined as Frictionless, that is, without friction. The contact between the lower surface of the beam and the left and right supports is defined as Frictional, that is, friction, and the friction coefficient is set to 0.2<sup>[8]</sup>.

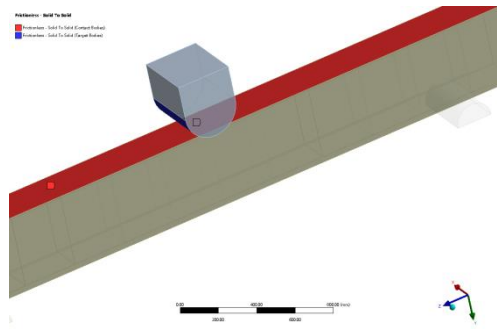

Fig.3 Schematic diagram of contact 1

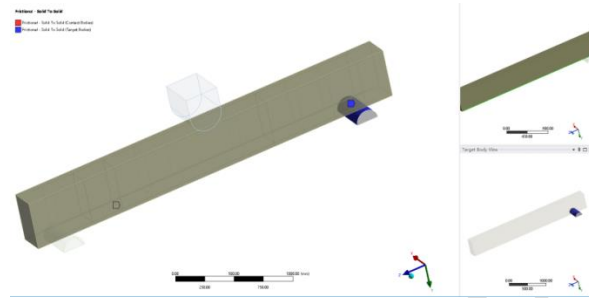

Fig.4 Schematic diagram of contact 2

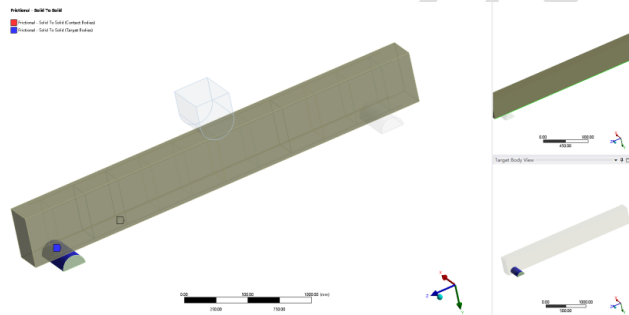

Fig.5 Schematic diagram of contact 3

### 3.4 Grid Division Settings

The grid method is employed to partition the model into regional grids, which are further subdivided into unstructured grids. The benefits of using an unstructured mesh include: the application of specific optimization criteria during the mesh generation process, resulting in high-quality meshes; ease of controlling mesh size and node density; and the utilization of a randomized data structure that facilitates adaptive gridding. Once the grid distribution is defined at the boundaries, the grid can be automatically generated within these boundaries without the need for partitioning or user intervention, and without requiring inter-subdomain communication. The grid division of the model is illustrated in Figure 8. Grid nodes of distinct entities are shared to ensure a clear and precise computational logic. Given that the reinforced concrete beam has the largest dimensions, the grid control size is set to a maximum of 30mm to maintain the accuracy of the calculations<sup>[9]</sup>.

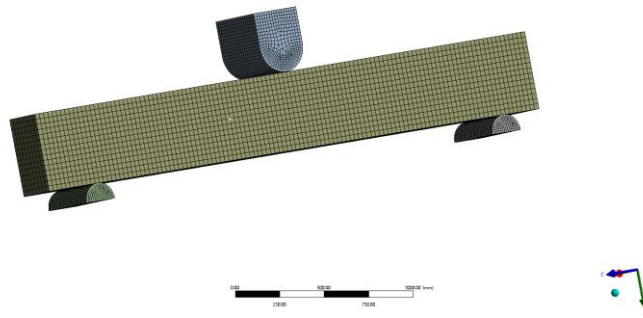

Fig.6 Model grid division diagram

### 3.5 Explicit dynamics Settings

To evaluate the damage to reinforced concrete beams, it is essential to apply an impact force to the target. In the analysis, the duration of the impact application is set to 0.01 seconds, with an acceleration of  $30 \text{ m/s}^2$  in the y-direction. The impact configuration is illustrated in Fig.7 and 8. Fixed constraints are applied to the two bottoms of the reinforced concrete beam. Fig.9.

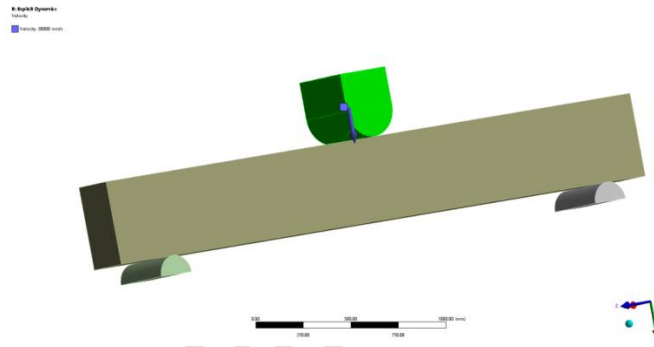

Fig.7 Impact location diagram

Scope	
Scoping Method	Geometry Sele...
Geometry	1 Body
Definition	
Input Type	Velocity
Pre-Stress Environment	None Available
Define By	Components
Coordinate System	Global Coordi...
<input type="checkbox"/> X Component	0. mm/s
<input checked="" type="checkbox"/> Y Component	30000 mm/s
<input type="checkbox"/> Z Component	0. mm/s
Suppressed	No

Fig.8 Shock application Settings

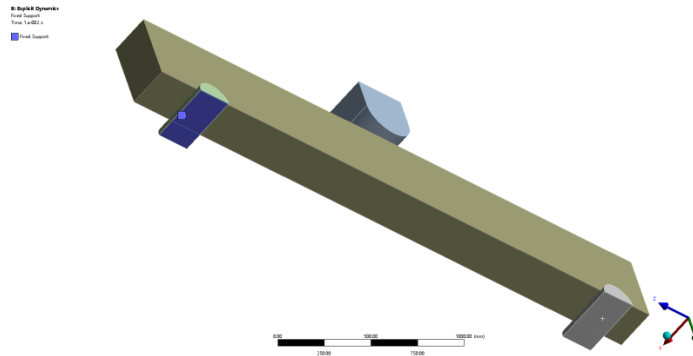

Fig.9 Constraint diagram of fixed end

### 3.6 Analysis of simulation results

After the impact is applied, the simulation calculation is carried out, and the total deformation cloud diagram of the reinforced concrete beam is shown in Fig.10. The maximum deformation of the beam is 164.12mm, and the maximum deformation occurs at the impact place and the center of the beam, and the minimum deformation occurs near the two lower supports. The equivalent stress cloud diagram of the reinforced concrete beam is shown in Fig.11. It can be seen that there is a large stress at the lower support position, and the stress is about 16MPa<sup>[11]</sup>. Due to the presence of steel bars inside the concrete beam, the maximum stress on both sides of the upper center is about 25Mpa.

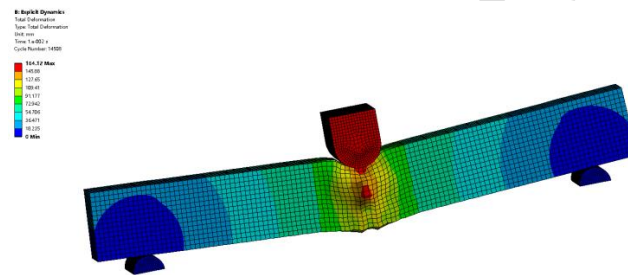

Fig.10 Total deformation cloud image

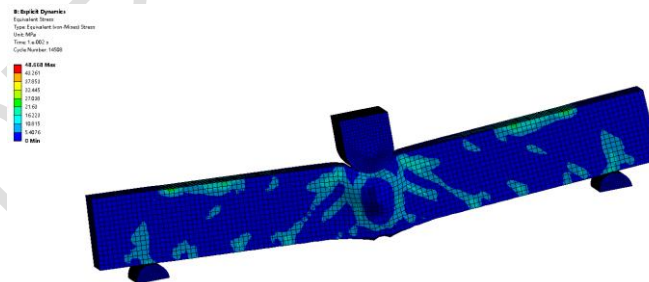

Fig.11 Equivalent stress cloud image

The equivalent elastic strain cloud diagram of the reinforced concrete beam is shown in Fig.12. It can be seen that the stress and strain do not show a corresponding relationship, and the strain basically appears in the corresponding part of the impact, and the maximum strain appears in the contact part of the impact object and the beam, and the maximum equivalent elastic strain is 0.01195mm/mm.

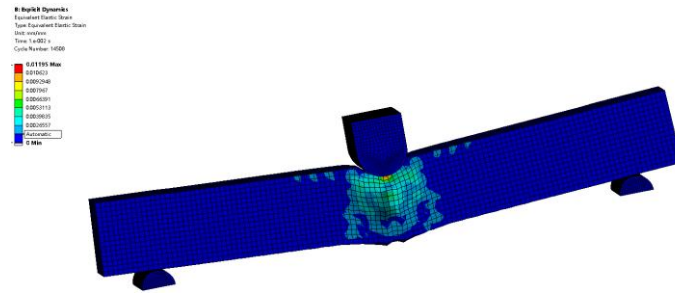

Fig.12 Equivalent elastic strain cloud image

The total damage cloud map is shown in Fig.13. In the cloud image, the red position represents complete failure, while the blue position represents no failure. It can be seen that the central position of the beam is basically completely damaged. Due to the force action of the rebar, the four longitudinal tendons have suffered great damage, and the stirrup at the lower support position also has some damage<sup>[12]</sup>. Hide the body of the beam. The total deformation cloud diagram of the steel bar can be obtained as shown in Fig.14. It can be seen that the upper longitudinal bar of the beam is larger than the lower two longitudinal bars. The closer it is to the impact object, the greater the shape variable of the steel bar.

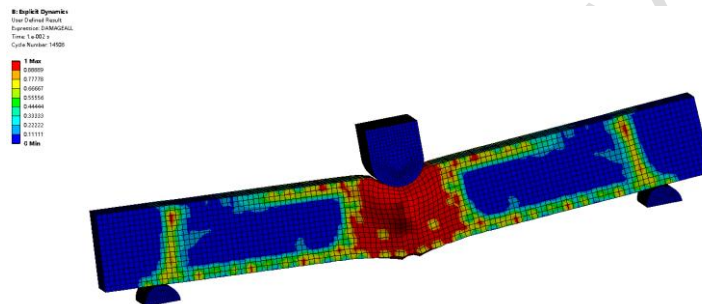

Fig.13 Total destruction cloud image

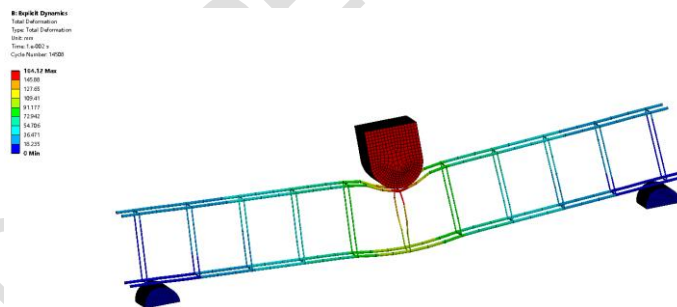

Fig.14 Cloud image of total deformation of steel bars

## 4 Conclusion

In this paper, the finite element model of reinforced concrete beam is established, the impact is applied to it by the method of display dynamics, and the change of beam is analyzed:

1. When the beam is subjected to load, it has a large displacement and deformation. The maximum displacement is 164.12mm.
2. The stress distribution is uneven, and the maximum equivalent stress is about 25Mpa, which exceeds the design limit value. This shows that there is a strong local failure phenomenon when the beam bears the load.
3. Due to the toughness of reinforced concrete materials, there is a certain degree of plastic deformation before the beam is damaged. This shows that the selected material has a certain toughness and ductility.
4. According to the failure cloud map, it can be seen that after the load reaches a

certain degree, the beam appears obvious cracks and failures, and the scope of failure gradually expands with the increase of the load.

In summary, the reinforced concrete beam has a large deformation and local failure phenomenon when subjected to load, and there is a certain degree of plastic deformation before the failure. Therefore, in the design and construction, it is necessary to rationally select and control the material, structure and load to ensure the safety and reliability of the structure.

#### Disclaimer (Artificial intelligence)

##### Option 1:

Author(s) hereby declare that NO generative AI technologies such as Large Language Models (ChatGPT, COPILOT, etc.) and text-to-image generators have been used during the writing or editing of this manuscript.

#### References

- [1] S. A E ,H. M A ,Ivo D ,et al. Experimental investigation on the behavior of fly-ash based geopolymer reinforced concrete beams strengthened with CFRP[J]. Heliyon,2023,9(7).
- [2] Bosse R M, Flórez-López J, Gidrão G M S, et al. Collapse mechanisms and fragility curves based on Lumped Damage Mechanics for RC frames subjected to earthquakes[J]. Engineering Structures, 2024, 311: 118115.
- [3] Elbana A, Junaid M T, Altoubat S. Flexural behavior and strengthening of geopolymer concrete beams reinforced with GFRP bars using CFRP sheets[C]//SynerCrete'18 International Conference on Interdisciplinary Approaches for Cement-based Materials and Structural Concrete. 2018: 449-454.11.
- [4] Miller K, Joldes G, Lance D, et al. Total Lagrangian explicit dynamics finite element algorithm for computing soft tissue deformation[J]. Communications in numerical methods in engineering, 2007, 23(2): 121-134.
- [5] Nguyen N T, Nguyen T K, Du D H. Nonlinear finite element analysis of FRP-strengthened full size reinforced concrete beams[J]. Innovative Infrastructure Solutions, 2023, 8(5): 139.
- [6] Cimellaro G P, Marasco S. Introduction to dynamics of structures and earthquake engineering[M]. Springer, 2018.
- [7] Le Hoang A, Fehling, E. Influence of steel fiber content and aspect ratio on the uniaxial tensile and compressive behavior of ultra high performance concrete[J]. Construction and Building Materials, 2017, 153: 790-806.
- [8] Leonardo C D M,Tiago P C D A ,José S R J.Shear strengthening of fire-damaged reinforced concrete beams using NSM CFRP laminates[J]. Engineering Structures,2023,287.
- [9] CHELLAPANDIAN, PRAKASH,S. SURIYA. Experimental and finite element

- studies on the flexural behavior of reinforced concrete elements strengthened with hybrid FRP technique[J]. Composite structures,2019,208(Jan.):466-478.
- [10] Do-Dai T, Chu-Van T, Tran D T, et al. Efficacy of CFRP/BFRP laminates in flexurally strengthening of concrete beams with corroded reinforcement[J]. Journal of Building Engineering, 2022, 53: 104606.
- [11] WuDS, Fan L D. Three neural networks for prestressed fiber-reinforced polymer/plastics sheet-reinforced concrete beams[J]. Journal of Asian Architecture and Building Engineering, 2024, 23 (2) : 613-633.
- [12] Mansal E C, Kankam C K, Biney E, et al. Flexural Behaviour and Environmental Impact of African Fan Palm Reinforced Concrete Beams under Symmetrical Loading Conditions[J].

UNDER PEER REVIEW