

# ECONOMIC EVALUATION OF PRUDENT ANTIBIOTIC USAGE CAMPAIGNS: ENHANCING HEALTHCARE QUALITY AND REDUCING COSTS

## ABSTRACT

**Background and Objective:** The irrational use of antibiotics is a major cause of antibiotic resistance and increases healthcare costs. Promoting prudent use of antibiotics is one of the efforts that must be made in hospitals to improve the quality of antibiotic use among healthcare workers. This study aims to evaluate the quality and cost analysis of antibiotic use in surgical cases at RSND Semarang before and after the campaign for prudent antibiotic use. **Method:** This study uses a quasi-experimental design with a one-group pre-test and post-test. The sample consists of 86 patient medical records of surgical cases that meet the inclusion and exclusion criteria at Rumah Sakit Nasional Diponegoro (RSND). The data needed to assess the quality of antibiotic use were obtained from medical records and then reviewed by the RSND PPRA team to determine the categories of antibiotic use quality according to Dr. Van Meer and Gyssens. The data were analyzed using the Chi-square test, and a cost analysis was conducted before and after the campaign for prudent antibiotic use. **Results:** The study found a significant difference in the quality of antibiotic use and the costs incurred for antibiotic use in surgical cases at RSND Semarang before and after the campaign for prudent antibiotic use. (Detailed results can be added based on the study's findings). **Conclusion:** The campaign for prudent antibiotic use had a positive impact on improving the quality of antibiotic use and reducing the costs associated with antibiotic use in surgical cases at RSND Semarang. This highlights the importance of such campaigns to improve antibiotic management in hospitals.

*Keywords: Cost analysis, antibiotic, Prudent use campaign, Quality assessment*

## 1. INTRODUCTION

Antibiotics are drugs that can inhibit the growth or kill microorganisms. Their use is intended for the prevention and treatment of microbial infections.[1] Unwise use of antibiotics is frequently encountered in both developed and developing countries. Hospitals are the primary sites where antibiotics are most extensively used. In hospitals, where there is a high volume of antibiotic usage, bacterial resistance to several antibiotics is common and

poses a major challenge in patient care[2]. Infections caused by resistant bacteria can lead to prolonged hospital stays, increased treatment costs, and even higher mortality rates. A study conducted in Switzerland in 2010 found that 9-46% of hospitalized patients received inappropriate therapeutic and prophylactic antibiotics. This prevalence study revealed that 37% of therapeutic antibiotic use and 16.6% of prophylactic antibiotic use were not in accordance with proper indications. [3]

Asian countries have been reported to have a higher prevalence of irrational antibiotic prophylaxis use (48%-100%) compared to developed countries (23.4%-55.2%). This is evident from a study conducted in Malaysia in 2012, which showed that 66.3% of prophylactic antibiotic use and 42% of therapeutic antibiotic use were not in accordance with proper indications[4]. The administration of prophylactic antibiotics to patients undergoing surgical procedures aims to prevent surgical site infections (SSIs), which can prolong hospital stays, double readmission rates, and triple treatment costs[5]

In hospitals, 98% of patients undergoing surgical procedures are given prophylactic antibiotics, but only 68% of their use aligns with established protocols. This inappropriate use can result in a 3-4 fold increase in therapeutic failure[6] Antibiotics should be administered with clear justification, as the growing development of bacterial resistance is closely associated with their usage. Therefore, prophylactic antibiotic use should be minimized, and the spectrum of activity of the drugs used should be as narrow as possible. Despite the established principles of prophylactic antibiotic use in surgery, inappropriate usage still persists.[7][8]

Based on the explanation above, the researchers deemed it necessary to conduct a study on the quality and cost analysis of antibiotic use in surgical cases at Diponegoro National Hospital (RSND) before and after the campaign for the prudent use of antibiotics..

## **2. RESEARCH METHODS**

This study was conducted at the Diponegoro National Hospital (RSND) using medical records from the surgery and obstetrics-gynecology departments, focusing on cases receiving antibiotic treatment. The study design was a quasi-experimental two-group pre-test and post-test approach combined with cost analysis. The sample size consisted of 172 surgical case medical records from Diponegoro National Hospital, comprising 43 medical records for the pre-campaign phase and 43 medical records for the post-campaign phase. The study evaluated the quality of antibiotic use based on the Van der Meer-Gyssens criteria and conducted a cost analysis.[9]

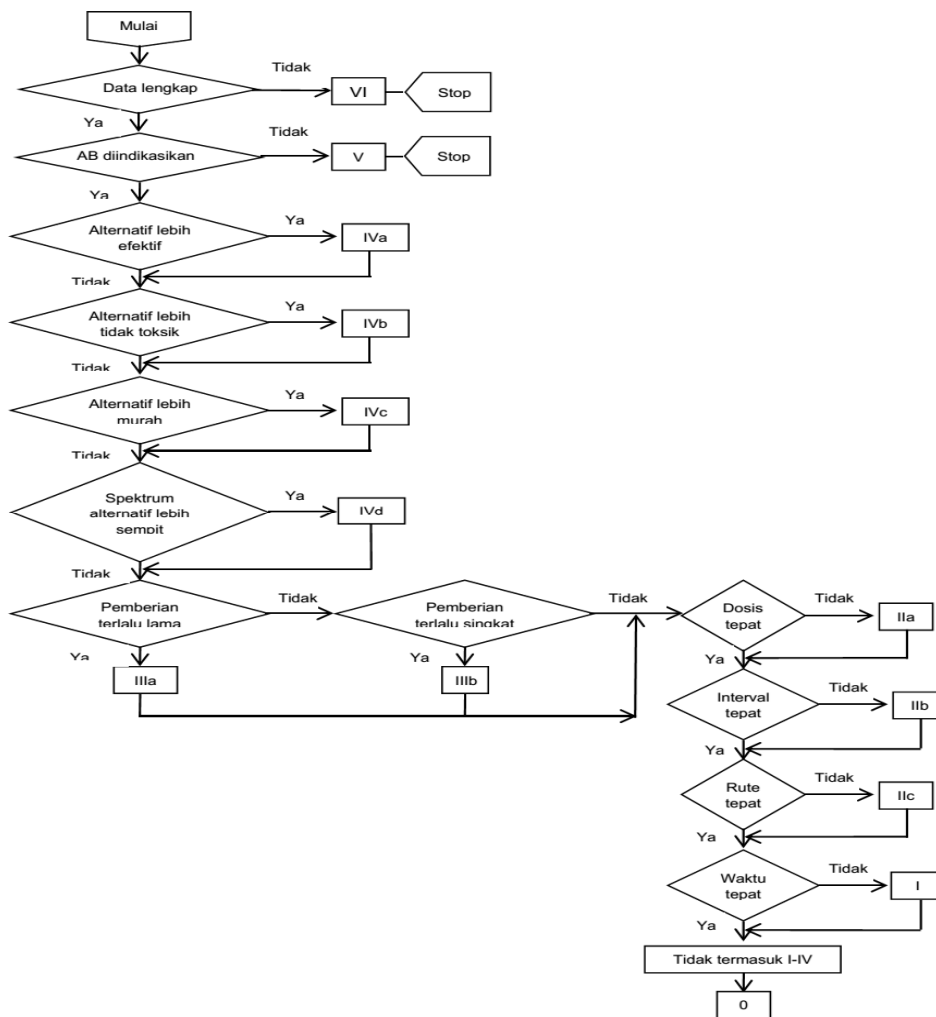

Figure 1. Flowchart of Antibiotic Use Quality Gyssens [10]

### 3. RESULT

The number of patient medical records for surgeries from September to November 2019 was 56, from which 44 medical records were randomly selected using simple random sampling, resulting in 76 antibiotic prescriptions. Based on the data regarding the distribution of antibiotic use from the 76 prescriptions for surgical patients at RSND, the most frequently prescribed antibiotics were Ceftriaxone, Cefazolin, and Cefadroxil. Additionally, based on the distribution of therapy types (Tabel 1)

Table 1. 1The distribution of therapy types

Therapy type	Case		Total prescriptions
	Surgical n = 55	Obstetric n = 21	
ADU	20 (36,4)	10 (47,6)	30 (39,5)
ADP	16 (29,1)	9 (42,9)	25 (32,9)
ADE	16 (29,1)	2 (9,5)	18 (23,7)
Aa	2 (3,6)	0 (0)	2 (2,6)
ADET	1 (1,8)	0 (0)	1 (1,3)

Note : ADU (Antimicrobial Drug Unknown Therapy). ADP (Antimicrobial Drug Prophylaxis). ADE (Antimicrobial Drug Empiric Therapy). Aa (Alternative agent). ADET (Antimicrobial Drug Extended Empiric Therapy)

In terms of therapy types for each antibiotic in surgical patients, the use of cefazolin and ceftriaxone was more commonly classified under the ADP type. Ceftriaxone was also predominantly used in the ADE type for surgical patients, while the ADU therapy type mainly used cefadroxil.

The quality of antibiotic use was assessed by reviewers based on Gyssens' criteria. The results of the quality assessment of antibiotic use in surgical patients at Diponegoro National Hospital (RSND) (Tabel 2)

Table 2. Results of Antibiotic Quality Assessment

Criteria for Antibiotic Quality	Frequency		Explanation	Percentage
	Bedah	Obgyn		
Category 0	4 (7,3)	7 (33,3)	Smart	11 (14,4)
Category IIA	6 (10,9)	2 (9,5)	Not smart	8 (10,5)
Category IIIA	5 (9,1)	0 (0)	Not smart	5 (6,6)
Category IVA	14 (25,4)	1 (4,7)	Not smart	15 (19,7)
Category V	26 (47,3)	11 (52,4)	No indication	37 (48,8)

The table above shows that the antibiotic quality category V, which represents "no indication for antibiotic use," was most commonly administered to surgical patients.

Cost analysis was performed on antibiotics directly given to surgical patients. The total direct costs for antibiotics in each quality category for surgical patients can be seen in the table below. (Table 3)

Table 3. The relationship between antibiotic quality and cost analysis

parameters	"Cost of antibiotic use" (rupiah)		Total cost (rupiah)	Gyssens criteria
	Surgical	Obstetric		
Unwise antibiotic quality (n=28)	992.604	50.028	1.003.630	Kategori I-IV

Antibiotic quality with no indication (n=37)	366.693	130.913	497.606	Kategori V
Appropriate antibiotic quality (n=11)	164.293	168.360	332.653	Kategori 0

From the table above, it is found that the use of inappropriate antibiotics has a higher cost value, followed by the cost of antibiotics with no indication, from the total of 76 antibiotic prescriptions.

#### 4. DISCUSSION

In this study, it was found that the use of antibiotics in surgical cases at RSND still heavily relied on ceftriaxone, accounting for 25% of prescriptions. Ceftriaxone was exclusively used in the surgical department, while other commonly used antibiotics were cefazolin and cefadroxil, which accounted for 18.4%. Cefazolin was more frequently used in the OB-GYN department compared to the surgical department, at 38.1%. The most common therapy type found was ADU. This remains an issue in the study by Catharina et al., where the ADU therapy type in the surgical department before the campaign was 69.6%, and 59.1% after the campaign.

In another study conducted by Usman Hadid et al. in 2001-2002 at educational hospitals in Surabaya and Semarang, it was found that in the Surabaya hospital, the antibiotic quality category 0 accounted for 25% in the OB-GYN department and 22% in the surgical department. Meanwhile, in the Semarang hospital, the antibiotic quality category 0 accounted for 10% in the OB-GYN department and 13% in the surgical department.[11]. For categories IIA, IIIA, and IVA (inappropriate use), this study found that in the surgical department, the rate was 45.4%, while in the OB-GYN department it was 14.2%. These figures are higher compared to an audit conducted by Usman Hadid et al. in 2001-2002, where in the Surabaya hospital, the inappropriate category was 13% in the surgical department and 12% in the OB-GYN department. In the Semarang hospital, the inappropriate category was 13% in the surgical department and 10% in the OB-GYN department. [12]The high rates of inappropriate antibiotic use in this study were attributed to the excessive use of the ADU type antibiotics due to unnecessary oral antibiotic switches for clean operations, as well as the high prescription of ADP type antibiotics, which were caused by incorrect antibiotic selection or incorrect dosing.[13]

In this study, the cost analysis for inappropriate antibiotic use in the surgical department amounted to 992,604 IDR, and in the OB-GYN department, it was 50,028 IDR, with a total cost of 1,003,630 IDR. For the cost associated with antibiotics without indication, the surgical department incurred 366,693 IDR, and the OB-GYN department had 130,913

IDR, totaling 497,606 IDR. In contrast, the cost for appropriate antibiotic use was lower, with the surgical department spending 164,293 IDR and the OB-GYN department 168,360 IDR, resulting in a total cost of 332,653 IDR.

Inappropriate antibiotic use and use without indication can lead to antibiotic resistance. Antibiotic resistance resulting from improper usage can increase healthcare costs, lengthen hospital stays, and raise morbidity and mortality rates. A recent report estimates that 10 million deaths will be associated with antibiotic resistance by 2050, and global economic losses will amount to 100 million dollars if substantial efforts are not made to address the threat of antibiotic resistance.<sup>26</sup>.

Several factors contribute to antibiotic misuse, including doctors prescribing antibiotics due to a lack of knowledge, patient influence, the pharmaceutical industry, hospital local policies, and other policymakers. Therefore, there is a need for Antibiotic Stewardship Guidelines in every hospital based on the microbial landscape and resistance patterns.

## **CONCLUSION**

Hospitals are the most common place for antibiotic use, making it essential to conduct ongoing studies to assess and evaluate doctors' knowledge, attitudes, and compliance with prudent antibiotic use. Effective antibiotic stewardship management plays a crucial role in reducing the costs associated with antibiotic use in surgical cases.

## **DISCLAIMER (ARTIFICIAL INTELLIGENCE)**

The authors hereby state that no generative AI tools such as large language models (ChatGPT, COPILOT, etc.) or text-to-image generators were utilized in the creation or editing of this work.

## **DATA AVAILABILITY**

All relevant data are included in the paper and its supporting information files. This study will assist researchers in identifying critical areas for Economic Evaluation of Prudent Antibiotic Usage Campaigns: Enhancing Healthcare Quality and Reducing Costs

Disclaimer (Artificial intelligence)

Option 1:

Author(s) hereby declare that NO generative AI technologies such as Large Language Models (ChatGPT, COPILOT, etc.) and text-to-image generators have been used during the writing or editing of this manuscript.

**Option 2:**

Author(s) hereby declare that generative AI technologies such as Large Language Models, etc. have been used during the writing or editing of manuscripts. This explanation will include the name, version, model, and source of the generative AI technology and as well as all input prompts provided to the generative AI technology

Details of the AI usage are given below:

1.

2.

3.

**REFERENCES**

- 1 T. M. Uddin *et al.*, “Antibiotic resistance in microbes: History, mechanisms, therapeutic strategies and future prospects,” *J. Infect. Public Health*, vol. 14, no. 12, pp. 1750–1766, 2021.
- 2 A. H. Ramdan, A. A. Mahmoud, R. N. Mohamed, R. A. Mowafy, M. E. Ali, and N. S. E.-D. A. Ali, “Influences Of Improper Use of Antibiotics on Public Health,” vol. 1, no. 1, pp. 41–60, 2024.
- 3 A. Cusini *et al.*, “Different patterns of inappropriate antimicrobial use in surgical and medical units at a tertiary care hospital in Switzerland: a prevalence survey,” *PLoS One*, vol. 5, no. 11, p. e14011, 2010.
- 4 L. M. Lim MunKit *et al.*, “Antibiotics in surgical wards: use or misuse? A newly industrialized country’s perspective,” 2015.
- 5 S. Dhole, C. Mahakalkar, S. Kshirsagar, and A. Bhargava, “Antibiotic prophylaxis in surgery: current insights and future directions for surgical site infection prevention,” *Cureus*, vol. 15, no. 10, 2023.
- 6 W. T. G. Chung *et al.*, “National surgical antibiotic prophylaxis guideline in Singapore,” *Ann Acad Med Singap*, vol. 51, no. 11, pp. 695–711, 2022.
- 7 WHO, “Step-by-Step Approach for Development and Implementation of Hospital Antibiotic Policy and Standard Treatment Guidelines.” World Health Organization, Regional Office for South-East Asia New Delhi, 2011.
- 8 U. Hadi *et al.*, “Cross-sectional study of availability and pharmaceutical quality of antibiotics requested with or without prescription (Over The Counter) in Surabaya, Indonesia,” *BMC Infect. Dis.*, vol. 10, pp. 1–10, 2010.

- [9] D. E. Putra, S. G. Pramudo, N. Arkhaesi, and D. Retnoningrum, "Antibiotic Prescribing Patterns During the Covid-19 Pandemic (A Case Study at Diponegoro National Hospital)," *Medica Hosp.*, vol. 8, no. 2, pp. 194–199, 2021.
- 10 R. Limato *et al.*, "Optimizing antibiotic use in Indonesia: A systematic review and evidence synthesis to inform opportunities for intervention," *Lancet Reg. Heal. Asia*, vol. 2, 2022.
- 11 U. Hadi *et al.*, "Audit of antibiotic prescribing in two governmental teaching hospitals in Indonesia," *Clin. Microbiol. Infect.*, vol. 14, no. 7, pp. 698–707, 2008.
- 12 U. Hadi *et al.*, "Survey of antibiotic use of individuals visiting public healthcare facilities in Indonesia," *Int. J. Infect. Dis.*, vol. 12, no. 6, pp. 622–629, 2008.
- 13 N. Bhatla, S. Singhal, E. Dhamija, S. Mathur, J. Natarajan, and A. Maheshwari, "Implications of the revised cervical cancer FIGO staging system," *Indian J. Med. Res.*, vol. 154, no. 2, pp. 273–283, 2021.

UNDER PEER REVIEW