

Short communication

An IoT-based Fuel Monitoring and Tracking System with Real-time Fuel Level Detection using Accelerometer

Abstract

In the transportation sector, effective fuel management is essential due to increasing environmental and economic concerns. However, traditional fuel level indicators often lack the necessary precision for optimizing fuel consumption. This paper introduces a novel IoT-based fuel monitoring and tracking system designed to overcome these challenges. By combining an accelerometer for real-time fuel level detection with GPS for location tracking and mileage calculation, the system provides comprehensive monitoring capabilities. Additionally, cloud-based data processing and a user-friendly mobile application enable real-time data visualization and analysis. This integrated approach empowers fleet managers and vehicle owners to make informed, data-driven decisions that enhance fuel efficiency, lower operational costs, and reduce environmental impact.

Keywords: IoT, accelerometer, GPS, Cloud-based data

1. Introduction

As the number of vehicles continues to rise, fuel consumption is also on the increase. While motor vehicles typically show fuel levels using indicators, such as bars ranging from E (empty) to F (full), these displays often do not accurately reflect the actual amount of fuel in the tank. This discrepancy can lead to inefficiencies and challenges in effective fuel management (Rosaline et al.,2019).A fuel level detector (fuel gauge) is a device inside of a car or other vehicle thatmeasures the amount of fuel still in the vehicle. This type of system can be used tomeasure the amount of gasoline or some other type of liquid. In this project fuel level intank, distance travelled by vehicle (mileage) and location of Vehicle, these 3 majorinformation is send to users application time to time. Accelerometer is used to measuredistance travelled by vehicle. It will typically consist of a sensing or sending unit thatmeasures the amount of fuel actually left and a gauge or indicator that relays thisinformation outside the fuel container. A GPS module is present to locate longitude andlatitudeofavehicle.Inthispresent study reference vehicle used was tractor and it is basedonIOT.

The Internet of Things (IoT) represents a network of interconnected computing devices, encompassing mechanical and digital machines, objects, and even living beings. The Internet of Things (IoT) is an added essence in the combination of hardware and software computing. Intelligent Transportation System (Trivedi *et al.*, 2020). These elements are equipped with unique identifiers and possess the capability to transmit data over a network, independent of human intervention (human-to-human or human-to-computer). In the transportation and construction industries, fuel management systems (FMS) play a critical role in meticulously measuring and governing fuel consumption. These systems capture data that can be subsequently stored within computerized systems. This data is then harnessed to generate reports that inform managerial decision-making. Consequently, FMS empowers stakeholders to exert control over fuel consumption, conduct cost analyses, and streamline tax accounting associated with fuel purchases. While modern vehicle tracking systems predominantly rely on Global Positioning System (GPS) technology for vehicle location purposes, alternative forms of automatic vehicle location technology can also be integrated (Khatun *et al.*, 2019).

Due to its far-reaching environmental and economic implications, the efficient management of fuel resources within the transportation sector is a critical concern. Traditional fuel level indicators often suffer from inaccuracies that hinder efforts to optimize fuel consumption and vehicle performance. Almishari *et al.*, (2017) proposed an IoT-based tracking system that leverages GPS for real-time tracking efficiency. This system offers an energy-efficient solution, reportedly reducing power consumption by 17% compared to conventional systems. The integration of such real-time tracking systems with FMS can offer significant benefits. By monitoring vehicle location and status data, FMS can potentially optimize routes, identify unauthorized vehicle usage, and detect abnormal engine behavior that might indicate inefficient fuel consumption. This combined approach can contribute to more comprehensive fuel management strategies within the transportation and construction sectors.

School bus safety remains a paramount concern for parents and administrators. To address this growing need, Shinde *et al.*, (2015) proposed and implemented an IoT-based system for real-time tracking and improved security of school buses. This system leverages readily available technologies to provide a cost-effective solution. The system continuously monitors the bus's location throughout its journey. If a deviation from the planned route is detected, indicating a potential security breach, the system triggers an alert mechanism. This alert typically involves sending a GSM message to designated personnel, such as school officials

or bus owners, notifying them of the irregular bus behavior. This prompt notification allows for timely intervention and ensures enhanced security for the children on board. The implementation of such an IoT-based system offers several advantages. Real-time tracking provides valuable insights into the location and movement of school buses, enabling better monitoring and ensuring adherence to designated routes. Additionally, the automatic alert system offers a crucial response mechanism in case of unforeseen circumstances.

Le-Tien and Phung-The, (2010) presented a practical model for outdoor vehicle tracking and monitoring utilizing a combination of Global Mobile Communication System (GSM) and Global Positioning System (GPS) technologies. The GPS receiver continuously captures the vehicle's location data (latitude and longitude). This data, along with the movement direction information from the accelerometer and compass sensors, is then transmitted to a central monitoring station. The system leverages Short Message Service (SMS) or General Packet Radio Service (GPRS) for data transmission via the GSM module. The central monitoring station, equipped with advanced GSM, receives and processes the transmitted data. This processed data, which incorporates the vehicle's location, movement direction, and potentially other sensor readings, is then visualized on a map platform like Google Maps. This real-time visualization allows for effective monitoring and control of the vehicles within the designated area.

Mistary and Chile, (2015) proposed a GPS-based vehicle tracking system for real-time location monitoring. This system employs readily available hardware components, making it a practical and potentially cost-effective solution. The use of a MATLAB-based GUI provides a potentially customizable and informative interface for monitoring purposes. However, further research could explore incorporating additional functionalities. For instance, integrating sensor data beyond GPS, such as fuel levels or engine diagnostics, could provide more comprehensive insights into vehicle operation.

Nandimathet *al.*, (2017) proposed a system that uses IoT technology to calculate the amount of fuel currently in a vehicle's tank. The system relies on a flow sensor and an ESP8266 (a microcontroller) to track fuel consumption. Transaction statistics are stored in a database. The system also offers a user-friendly Android application that displays real-time fuel level and location information. Additionally, it can potentially raise alerts if fuel consumption deviates from expected ranges. An advantage of this system is its cost-effectiveness, as it utilizes the

ESP8266 instead of the more expensive Raspberry Pi. However, the paper acknowledges potential drawbacks. Slower internet speeds can cause delays in data transmission and web application updates. The authors suggest that future advancements will likely address these limitations.

Chiwhaneet et al., (2017) explores a system that utilizes Internet of Things (IoT) technology to calculate the amount of fuel currently present in a vehicle's tank. This innovative approach overcomes limitations found in existing systems by providing real-time fuel level data. This app provides users with real-time insights into both fuel level and current vehicle location. Additionally, it has the potential to analyze fuel consumption and generate alerts if it deviates from expected patterns, considering variations in fuel prices across different locations. A significant advantage of this system lies in its cost-efficiency. It employs the ESP8266 microcontroller, a more budget-friendly alternative to the Raspberry Pi often used in existing systems. However, the paper acknowledges some limitations. Slower internet speeds can introduce delays in transmitting data and updating the web application associated with the system. The authors express confidence that future advancements will address these issues.

Suret et al., (2020) conducted a project to monitor the fuel level from a distant place and in case of theft can be detected easily from that place. For this, a level sensor will be needed which continuously will take the readings of the level of fuel at the tank (vehicle tank or any reservoir) and this level sensor will be connected to a microcontroller input. The IoT implementation part is the level of the fuel can be continuously monitored by displaying it on a website using an ESP8266 NodeMCU.

With this review of literature, this research presents the development of an IoT-based fuel monitoring and tracking system that addresses these limitations. This innovative system leverages advancements in sensor technology, wireless communication, and cloud computing to provide a comprehensive solution for real-time fuel level monitoring, vehicle location tracking, and mileage calculation. By capturing and analyzing these critical data points, the system empowers fleet managers and individual vehicle owners to make data-driven decisions that optimize fuel efficiency, reduce operational costs, and minimize environmental impact. By integrating a combination of hardware components, including accelerometers, GPS modules, and microcontrollers, along with software applications and cloud-based infrastructure, the proposed system offers a comprehensive solution for real-time fuel level

monitoring, vehicle location tracking, and mileage calculation. This system aims to provide valuable insights into fuel consumption patterns, enabling data-driven decisions for optimizing fleet management and reducing operational costs. The following sections delve into the hardware and software components employed their integration, and the system's overall functionality.

UNDER PEER REVIEW

Table 1: Comparison between the current technologies.

Reference	System Purpose	Core Technologies	Additional Features	Advantages	Limitations
Almishari et al., (2017)	Real-time vehicle tracking	GPS, Cloud storage, Android App	Temperature sensor	Energy-efficient (reduced power consumption)	Relies on cloud processing
Shinde et al., (2015)	Real-time school bus tracking and security	GPS, Raspberry Pi (computer), GSM/GPRS modules	Predefined waypoints database, Automatic alerts	Cost-effective, Improved security	Limited to GSM/GPRS network coverage
Le-Tien and Phung-The, (2010)	Outdoor vehicle tracking and monitoring	GPS, GSM, Accelerometer, Compass	SMS/GPRS data transmission	Real-time tracking with movement direction	Requires additional setup for compass and accelerometer
Mistary and Chile, (2015)	Real-time vehicle location monitoring	GPS, MATLAB-based GUI	-	Cost-effective, Customizable interface	Lacks functionalities beyond GPS data
Nandimath et al., (2017)	Real-time fuel level monitoring	Flow sensor, ESP8266 microcontroller, Database	Android App with fuel alerts	Cost-effective, User-friendly interface	Relies on internet speed for updates
Chiwane et al., (2017)	Real-time fuel level monitoring	Flow sensor, ESP8266 microcontroller, Database	Android App with fuel consumption analysis	Cost-effective, User-friendly interface	Relies on internet speed for updates

3. Design and development

System Architecture

Traditional fuel level indicators often suffer from inaccuracies. To address this, a digital fuel indicator system is proposed, providing precise fuel level, location, and mileage information. This system offers a cost-effective and versatile solution applicable to various vehicle types. Unlike conventional systems relying on fuel sensors, this approach utilizes an accelerometer (ADXL335) for fuel level detection. A bob attached to the accelerometer floats within the fuel tank. As the fuel level decreases, the bob's position changes, causing the accelerometer to tilt. Pre-calibrated tilt angles correspond to specific fuel levels, which are stored in a database. An Arduino microcontroller (ATmega328P) processes these tilt values and converts them into fuel level readings in liters. The Arduino subsequently transmits the fuel-level data to a Wi-Fi module (ESP8266) for cloud-based storage and processing. A GPS module is integrated to determine the vehicle's location. Based on fuel consumption and location data, the system calculates the distance traveled. The collected data is uploaded to a cloud platform, such as Salesforce's Ais Cloud, designed to handle large volumes of IoT data. This cloud infrastructure enables real-time data processing and analysis. The processed information is then displayed on a user-friendly Android application, presenting the vehicle's location on a Google Maps interface. This innovative system offers a more accurate and informative alternative to traditional fuel level indicators, providing valuable insights for vehicle owners and fleet management (Fig 1).

The ADXL335 is a small, thin, low power, complete 3-axis accelerometer with signal conditioned voltage outputs. The product measures acceleration with a minimum full-scale range of $\pm 3 g$. It can measure the static acceleration of gravity in tilt-sensing applications, as well as dynamic acceleration resulting from motion, shock, or vibration.

The user selects the bandwidth of the accelerometer using the CX, CY, and CZ capacitors at the XOUT, YOUT, and ZOUT pins. Bandwidths can be selected to suit the application, with a range of 0.5 Hz to 1600 Hz for the X and Y axes, and a range of 0.5 Hz to 550 Hz for the Z axis.

The ADXL335 is available in a small, low profile, $4 \text{ mm} \times 4 \text{ mm} \times 1.45 \text{ mm}$, 16-lead, plastic lead frame chip scale package (LFCSP_LQ). An accelerometer is an electromechanical device that will measure acceleration forces. These forces may be

static, like the constant force of gravity pulling at your feet, or they could be dynamic-caused by moving or vibrating the accelerometer.

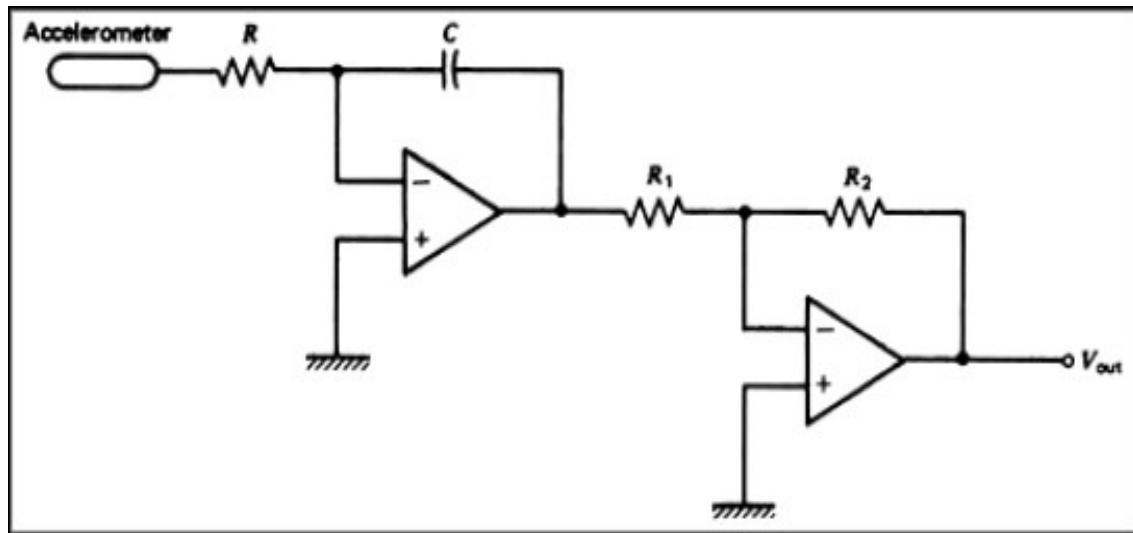

An integrator can be used to obtain velocity information from an accelerometer.

Figure 1: Flow diagram of the proposed system

To enhance fleet management efficiency and enable proactive journey planning an IoT-based fuel monitoring and tracking system is proposed. By leveraging real-time data on fuel levels, vehicle location, and mileage, the system aims to optimize fuel consumption and optimize routes based on dynamic conditions. The system employs an accelerometer to monitor fuel level changes within the vehicle's fuel tank. As the fuel level fluctuates, the accelerometer's tilt angle varies accordingly. This tilt data is processed by an Arduino microcontroller to calculate the corresponding fuel level. Simultaneously, a GPS module determines the vehicle's latitude and longitude, which, along with the calculated fuel level, is transmitted to a Wi-Fi module. The ESP8266 Wi-Fi module relays the collected data to a cloud-based platform. To visualize vehicle location, a mobile application named "Tracer" is developed and linked to the cloud platform. The application displays the vehicle's real-time position on a Google Maps interface. The system updates the cloud-based data every 30 seconds, ensuring timely information dissemination. The application reflects these updates, providing users with the vehicle's current location and fuel level. Additionally, the system generates graphical representations of fuel consumption patterns for analysis and optimization. This IoT-based

solution offers a comprehensive approach to fleet management by providing granular insights into fuel usage, vehicle location, and driving patterns (Fig 2a and 2b).

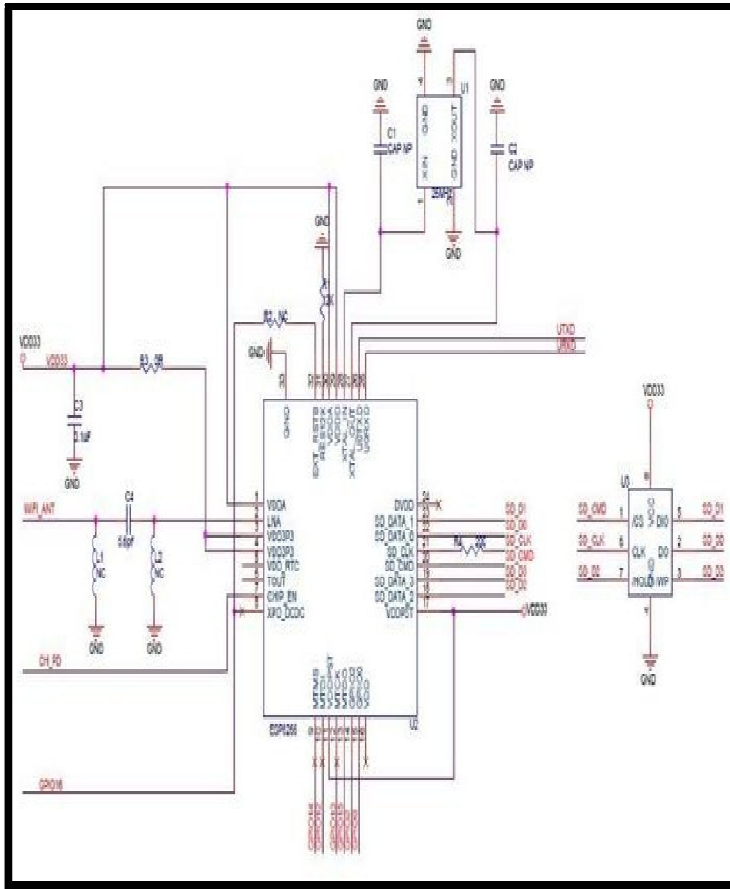

Fig.2a

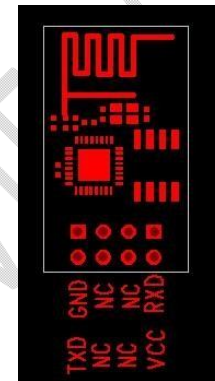

Fig.2b

Fig.2a and 2b schematic and pin diagram

4. Conclusion

This study has presented a novel IoT-based digital fuel monitoring and tracking system that surpasses the limitations of traditional fuel level indicators. The system leverages advancements in sensor technology, including accelerometers and GPS, to provide real-time fuel level data, vehicle location tracking, and mileage calculation. This comprehensive data acquisition empowers fleet managers and individual vehicle owners to make data-driven decisions that optimize fuel efficiency, reduce operational costs, and minimize environmental impact. The proposed system offers several advantages over existing solutions. Firstly, the utilization of an accelerometer provides a more accurate and cost-effective method for fuel

level detection compared to traditional fuel tank sensors. Secondly, the integration of cloud-based processing and a user-friendly mobile application enables real-time data visualization and analysis, fostering informed decision-making. Finally, the system's ability to calculate mileage and generate fuel consumption patterns allows for proactive journey planning and route optimization, contributing to reduced fuel waste and environmental impact.

Future research efforts could explore further refinement of the system's functionalities. Integration of additional sensors, such as those monitoring engine performance or tire pressure, could provide even more granular insights into vehicle operation. Additionally, exploring alternative data transmission protocols with lower latency could offer near real-time data updates, enabling even more immediate response and decision-making capabilities. Overall, this research paves the way for the development of more efficient and environmentally responsible fleet management practices through the power of IoT technology.

Disclaimer (Artificial intelligence)

Author(s) hereby declare that NO generative AI technologies such as Large Language Models (ChatGPT, COPILOT, etc.) and text-to-image generators have been used during the writing or editing of this manuscript.

5. Reference

1. Almishari, S., Ababtein, N., Dash, P. and Naik, K. (2017), "An energy efficient real-time vehicle tracking system", *2017 IEEE Pacific Rim Conference on Communications, Computers and Signal Processing (PACRIM)*, IEEE, pp. 1–6, doi: 10.1109/PACRIM.2017.8121884.
2. Chiwhane, S.A., Deepa, M. and Shweta, K. (2017), "IOT Based Fuel Monitoring for Future Vehicles.", *International Journal of Advanced Research in Computer and Communication Engineering*, Vol. 6, pp. 295–297.
3. Khatun, R., Antor, S.A., Ullah, A. and Hossain, A. (2019), "Vehicle Fuel Activities Monitoring System Using IoT", *Advances in Internet of Things*, Vol. 09 No. 04, pp. 63–71, doi: 10.4236/ait.2019.94005.

4. Le-Tien, T. and Phung-The, V. (2010), "Routing and Tracking System for Mobile Vehicles in Large Area", *2010 Fifth IEEE International Symposium on Electronic Design, Test & Applications*, IEEE, pp. 297–300, doi: 10.1109/DELTA.2010.38.
5. Mistary, P. V and Chile, R.H. (2015), "Real time Vehicle tracking system based on ARM7 GPS and GSM technology", *2015 Annual IEEE India Conference (INDICON)*, IEEE, pp. 1–6, doi: 10.1109/INDICON.2015.7443571.
6. Nandimath, J.N., Sayali, J. and Pradnya, C. (2017), "IoT based fuel monitoring for future vehicles. ", *International Research Journal of Engineering and Technology (IRJET)*, Vol. 4 No. 2, pp. 1361–1363.
7. Rosaline, S., Sheela, J. J. J., Hasmitha, M., & Rajitha, C. (2019). An effective IoT based fuel and cost monitoring system. *International Journal of Recent Technology and Engineering*, 8(3), 4080-4083.
8. Shinde, P.A., Mane, Y.B. and Tarange, P.H. (2015), "Real time vehicle monitoring and tracking system based on embedded Linux board and android application", *2015 International Conference on Circuits, Power and Computing Technologies [ICCPCT-2015]*, IEEE, pp. 1–7, doi: 10.1109/ICCPCT.2015.71594.
9. Sur, D., Firdaus, J., Dutta, R., Purohit, A., Mitra, D., & Majumder, K. (2019). IoT based fuel level monitoring and fuel theft detection system. *PREPARE@ u®/ General Preprint Services*.
10. Trivedi, J., Devi, M.S., Dhara, D.(2020), Canny edge detection based real-time intelligent parking management system, *Scientific Journal of Silesian University of Technology. Series Transport*. 2020, 106, 197-208. ISSN: 0209-3324. DOI: <https://doi.org/10.20858/sjsutst.2020.106.17>.