

Review Article

Model Conversion and Application Framework for Rectangular Aqueduct Superstructures: Integrating Revit and Midas Civil

ABSTRACT

To improve the modeling efficiency of finite element analysis models for rectangular aqueducts based on the BIM information model, this study proposes a model conversion method that integrates Revit software and Midas Civil. By accessing the attribute information stored in the structural component objects of the BIM model, the finite element modeling parameters required for structural analysis are obtained. A secondary development program has been established using the C# programming language on the Visual Studio 2022 platform, resulting in the creation of a model interface program (Revit-Midas Civil) that facilitates the conversion of model information. This has saved designers time in constructing finite element models. The feasibility and reliability of the proposed model conversion method have been validated through a multi-girder rectangular aqueduct. The results indicate that the model conversion method successfully transformed structural analysis model information from Midas Civil into Revit model information, significantly enhancing the modeling efficiency and accuracy of rectangular aqueduct structures.

Keywords: BIM; Midas Civil; rectangular aqueduct; conversion interface; secondary development; Revit Application Programming Interface (API)

1. INTRODUCTION

With the development of intelligent construction and building industrialization, the traditional civil engineering industry is moving towards data-driven and intelligent directions. At the same time, the advantages of informatization and visualization are gradually becoming prominent in design applications [1]. BIM technology is also widely applied in various stages of projects [2-5]. The full-process application of BIM technology can improve project work efficiency and reduce information asymmetry. Components drawn with BIM have parametric characteristics. The attribute data of each component stored in the BIM platform can provide a basis for collaborative design among different disciplines. BIM can also realize data sharing among multiple disciplines, promote collaboration among them, and improve design efficiency and drawing quality [6-8]. Therefore, utilizing BIM technology plays a crucial role in promoting data-driven and intelligent development in the field of architectural engineering.

In the collaborative work between BIM software and structural design software, Jia [8] et al. proposed an automatic generation method for finite element models based on BIM and ontology, which uses the IFC [10] standard to semantically interpret BIM models and extract geometric information, thereby automatically generating finite element models that meet the

analysis requirements. With the continuous improvement of informatization technology in the construction industry, the incomplete and unsmooth data exchange between different software is hindering the development of the industry, causing a huge waste of human and financial resources. Therefore, to promote the interoperability between different industries and software, the Industry Alliance for Interoperability proposed and formulated the IFC (Industry Foundation Class) data model standard in 1995. Although Midas and Revit support the export and import of IFC format files, due to the different mapping of the IFC standard by each software, the model information that can be mutually converted is minimal. The unification and expansion of the IFC standard is currently a major research direction. Dynamo, as a graphical programming tool for Revit, provides the possibility of customized workflows. Through Dynamo, users can create specific scripts in Revit to automate the creation and modification of models. These achievements can greatly reduce the time, errors, and workload required for lifecycle assessment and lifecycle cost analysis, provide designers with real-time decision support data, and make important contributions to using BIM for sustainable development purposes [11-12]. Although the complexity of model conversion between Revit and FEA software has been addressed by Wang et al., ensuring consistency in geometric precision and physical properties, thereby enhancing the efficiency and accuracy of the cross-platform architectural design and structural analysis process, this research is primarily focused on the field of bridges and is not applicable to the conversion and analysis of aqueduct structures within hydraulic engineering [133-166]. Under the background of rapid development of intelligent water conservancy, the reasonable application of computer analysis software in water conservancy projects has become an important part of improving project management capabilities. In this study, Tan Zheng [17] focused on Midas calculation software and elaborated on the application scheme of Midas calculation software from multiple dimensions. Zhu Dingguo [18] et al. applied cross-platform collaboration between 3D modeling software and numerical simulation software, establishing a standardized high-precision simulation analysis model construction process, covering functions such as simplified export of BIM models, numerical simulation import, mesh generation, boundary condition input, and combination display of calculation results and 3D models, aiming to improve the construction efficiency of high-precision simulation analysis models and provide high-quality basic models and technical support for water conservancy project 3D design research. Zhang Wei [19] took a certain aqueduct as an example and used the bridge engineering software Midas Civil for structural calculation and analysis in combination with hydraulic specifications, intuitively realizing structural calculation and verification, and better guiding the engineering structural design. It can greatly simplify the calculation model and improve work efficiency. However, these studies lack the conversion related to BIM model software. Midas Civil is a finite element calculation software widely used in engineering structure calculation and analysis, especially in bridge design [20], and it is also suitable for finite element analysis of some equal-section and rod system structures. This provides calculation support for our rectangular aqueduct structure. However, in the forward design based on BIM information models, research in this area is still relatively scarce, which can be summarized as the following difficulties: First, although there are many types of BIM software, such as Revit, CATIA, Bentley, and ArchiCAD, among which Revit has the largest user base in China, its structural analysis function is insufficient and cannot meet the requirements of domestic specifications. The data types are relatively closed, and structural analysis and calculation are still an isolated part of the design process; Second, now or for a long time, it is noteworthy that, at present and for an extended period, a transition phase is being undergone, characterized by the "model flipping" from 2D drawings to 3D. This transition makes it impractical to fully unleash the productivity of BIM models and effectively harness the information embedded within the calculation models, inadvertently leading to an increase in production costs.

Practice shows that although Revit and Midas Civil have significantly different functions, they can be combined to leverage their strengths and complement each other in building model design. Revit software can build information-rich architecture, structure, and MEP models, and professional designers can use Revit's powerful programmability to extend and realize automatic checking of engineering rules, document generation, and multi-disciplinary collaborative design work. On the other hand, Midas Civil software has more advantages in engineering structure modeling and analysis calculations. Therefore, combining the model conversion information of the two software can give full play to their respective advantages and design building models by leveraging their strengths. This study proposes a conversion interface between Revit and Midas Civil models to facilitate the conversion between BIM and structural design, and verifies its reliability through practical engineering, hoping to provide a reference for similar projects.

To address the above issues, a focused study is conducted on the 3D modelling of the existing mainstream BIM software (Autodesk Revit) and the structural analysis function of the mainstream structural design and analysis software (Midas Civil). This paper takes the rectangular aqueduct as the research object, aiming to combine BIM technology with traditional technology in practical engineering, reduce the tediousness and possibility of errors in data conversion, and improve the work efficiency at the structural analysis stage. Combining the practical application of rectangular aqueducts in civil engineering, this paper explores the connection between the data interfaces of the two, proposes a data conversion strategy based on the Revit secondary development platform, and applies the method to engineering examples, thereby verifying the rationality and reliability of the proposed conversion strategy and laying the foundation for further collaboration between the two.

2. METHODS

2.1 INFORMATION INTERACTION METHODS

Each software has a specific internal data text format, which can be perfectly compiled, imported, and exported within the software, such as AutoCAD's .SCR files and Midas's .MCT files. Therefore, information mapping based on specific internal data text formats can achieve data exchange between two software. In view of this, this paper proposes a Revit-Midas Civil model conversion method (Figure 1), and the specific conversion steps are as follows:

i. Model Processing. The BIM model is divided into multiple units to allow the program to obtain the coordinate information, number of units, and unit length information of each unit. The support nodes are positioned and simulated according to the specific conditions of the analysis model.

ii. Transfer of Key Section Parameters. The required section parameters of the beam units are extracted from the beam BIM model, and the section properties are calculated in the section property calculator in Midas and added to the design numerical section (PSC Value) in Midas.

iii. Transfer of Material Parameters. The material information required by the Midas software is obtained from the material properties that can be added when establishing the BIM model, which is convenient for the program to identify and acquire.

iv. Transfer of Prestressed Tendons. The handling of prestressed tendons is a key step in converting the BIM model to the Midas software. Based on the coordinates of the prestressed ducts in the BIM model, the program converts them into prestressed tendon information in the MCT format that can be recognized by the Midas software and outputs them to the MCT file.

v.Division of Construction Stages. For multi-girder rectangular aqueduct structures, the construction stages can be divided into T-beam fabrication, prestressing, beam storage, lifting overweight, beam lowering, cross-beam casting, trough body casting, full water weight, and 10-year shrinkage and creep.

vi.MCT File Generation. By writing the MCT file through the program and importing it into the Midas software, the corresponding finite element analysis model can be automatically created. After ensuring the necessary conditions, analysis and calculation can be performed.

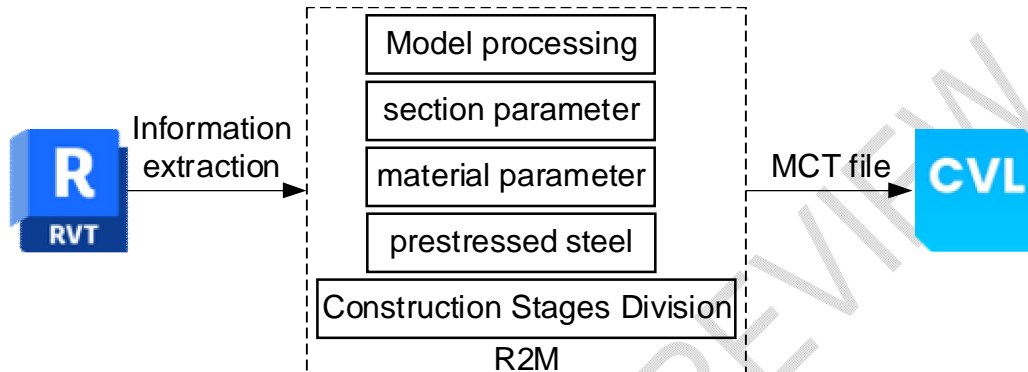

Fig. 1 Revit-Midas model conversion methodology

2.2 PROGRAMME DEVELOPMENT METHODOLOGY

Based on the Visual Studio 2022 platform, this research carries out secondary development, selecting .NET 8.0 as the target framework and using the C# programming language to realize the extension of the Revit to Midas (R2M for short) functionality. The Revit SDK is the official software development kit for Revit, which includes an external program manager, samples, RevitAPI, and other available tools. Revit Lookup can be used to query the properties and parameters of components, which helps developers understand parameter types and how to obtain parameters during the development process, thus achieving interactive access with structural software. The Add-In Manager can be used to load the code written in Visual Studio to implement the relevant functions of Revit. Figure 2 shows the application process of the API that Revit secondary development needs to follow [21-22]:

- i.Create a new class library in the development project and add references to RevitAPI.dll and RevitAPIUI.dll corresponding to the Revit version.

- ii.Create a new class that inherits from IExternalCommand, implement the interface, and add a non-modal form startup program in its overloaded method Execute(). Specify the API's transaction mode and model update mode as Manual, i.e., TransactionMode.Manual and RegenerationOption.Manual.

- iii.Add a class that inherits from the external event IExternalEventHandler, and add a background program for processing data and editing the model in its Execute(). In public string GetName(), return the class name so that it can be triggered in the Button of the form.

- iv.To add a RibbonPanel for the program, inherit from IExternalApplication to implement the external application starting from the Revit program and exiting when Revit is closed.

- v.Complete the code compilation, generate the solution, and verify the program after successful debugging.

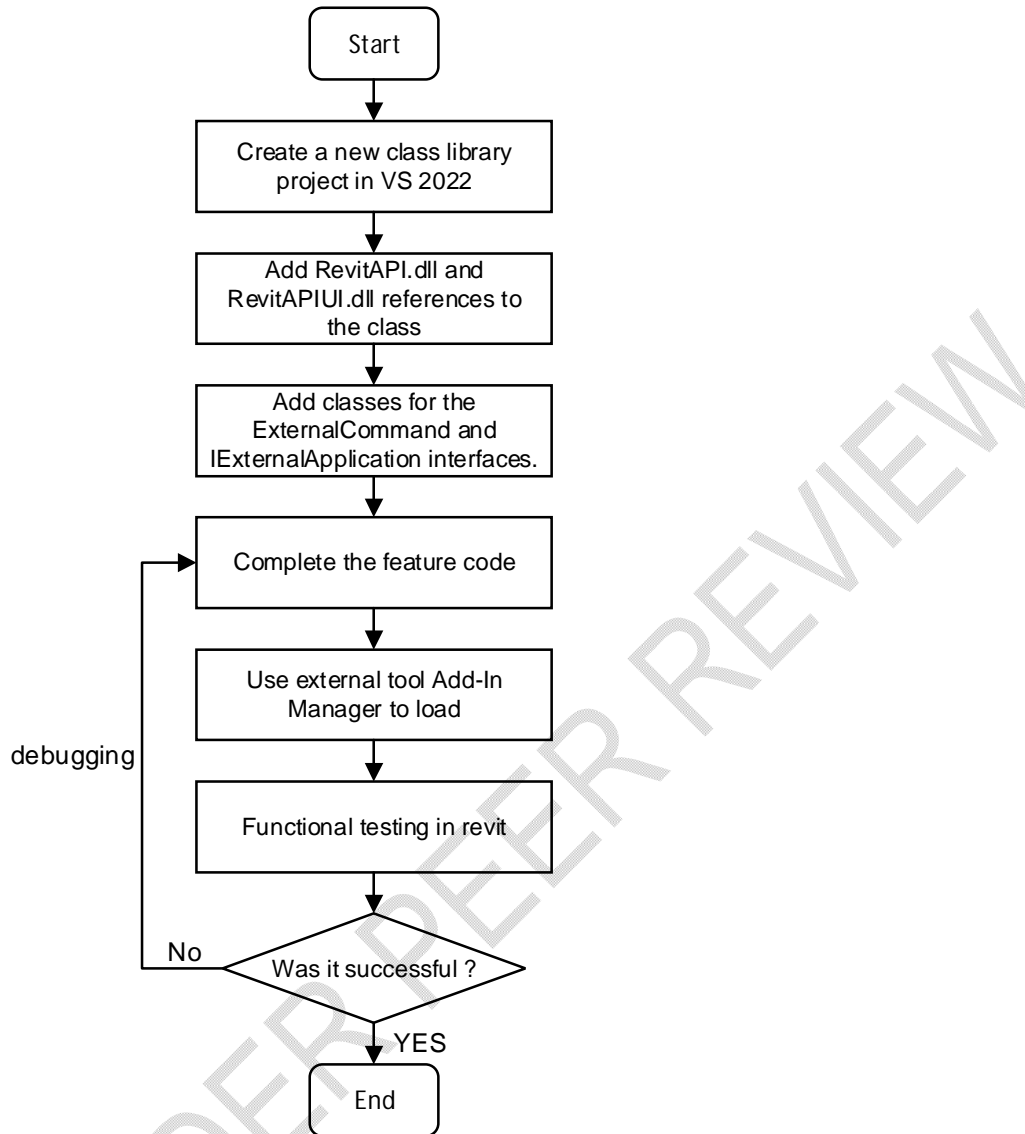

Fig. 2 Secondary development flow chart

The implementation of the conversion method for the Revit-Midas Civil model based on rectangular aqueducts primarily relies on three platforms: Revit, M2R, and Midas Civil. The model information in Revit mainly includes cross-sectional characteristics, material properties, geometric dimensions, and boundary conditions. When conducting structural analysis using Midas Civil, it encompasses load conditions, boundary conditions, construction stages, etc. A comparison of the model information is shown in Table 1.

Table 1. Comparison of Revit and Midas model information

Data in Revit	Data in Midas	MCT Document Keywords
Instance ID, Coordinates	Node, Element	*NODE、*ELEMENT
Material Information	Material	*MATERIAL
Section	Section	SECT-PSCVALUE、*SECTION
Boundary condition	Boundary condition	*BOUNDARY
Load	Load	*LOAD

As shown in Table 1, the information obtainable from both platforms is largely consistent. Therefore, the data extraction and storage can be achieved using Revit API for secondary

development, generating the corresponding MCT files and thus facilitating the model conversion between Revit and Midas. The main designed functionalities of the program include element division, information conversion, data translation, and file output, etc. Since the number of entities in the BIM model file of the aqueduct structure is often determined by the number of engineering beam segments, a single-span structure can be selected for accurate acquisition during structural calculations. The specific method is shown in Figure 3. First, Revit utilizes its visualization and parameterization features to establish a BIM structural model; then, by sorting out the information needed for analysis and calculation and using Revit's secondary development tools, a conversion interface is established; combined with the knowledge of civil engineering, the relevant structural information of the Revit model is transferred into Midas Civil for analysis and calculation according to certain rules; then, the analysis and calculation results are fed back to the Revit model, and each discipline can communicate design intentions on the same BIM model and modify the model information, truly achieving multi-disciplinary collaboration simultaneously without interference.

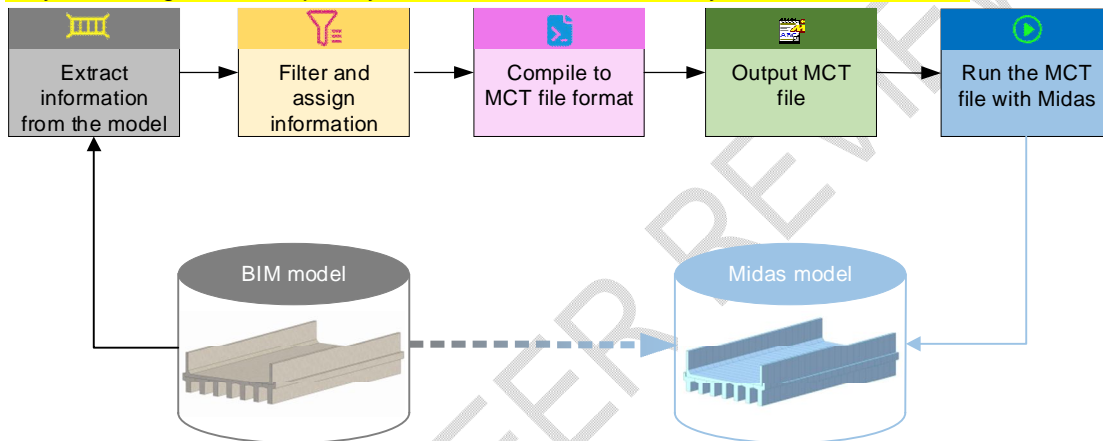

Fig. 3. Model transformation method

2.3 MODEL CONVERSION PROCEDURE

In the R2M loading and optimization process, the first step is to complete the compilation of the program code for model conversion and reinforcement functionality. Once this process is completed, an extension .dll file will be generated. Next, to load this .dll file into the Revit platform, **The external tool Add-In Manager needs to be utilized.** The specific user interface is shown in Figure 4.

To further enhance the convenience of program operation, **The external application interface, namely IExternal Application, is utilized to invoke the previously developed program code.** This allows us to add a new tab named "Converter" in the Revit interface. Within this tab, a conversion function button, labeled R2M, is also included. This way, the plugin's functionality can be intuitively presented in the Revit interface, as illustrated in Figure 5.

To facilitate subsequent calculations in Midas software, the R2M program requires users to select any superstructure from any chosen span. After selection, the specific parameters obtained will be displayed in a preset table. These parameters not only include basic structural information but also support users in making necessary modifications. If users encounter errors during selection or if information is missing due to omitted elements in the BIM model, the parameter definitions in the preset table can refer to Table 2. Users can select the model by clicking the "Select The Aqueduct Structure" button, which allows them to frame or click multiple times to choose the superstructure model of the rectangular flume. The parameters of the selected model will appear in the preset table, while any empty

values will not be displayed. If users discover any issues during verification, they can manually adjust data or click the "Clear The Data" button to reset the data and make a new selection. The specific operational interface is shown in Figure 6.

Once users confirm that all data is correct, they can click the "Export The Data" button to export the data as an MCT file, which will automatically open for user review.

After the R2M programme has successfully generated the MCT file, the next step is to import the file into the Midas software. After importing, a finite element model of the rectangular ferry superstructure can be generated, which not only includes detailed information such as nodes, cells, materials, and prestressing steel bundles, but also provides a solid foundation for the subsequent calculation work. However, for the calculations to proceed, key information such as loads, boundary conditions, construction phases, etc. must also be further added and improved on the basis of the generated model. In this way, the accuracy and reliability of the calculation results can be ensured. Figure 7 shows the converted Midas model, and Figure 8 shows the Revit model.

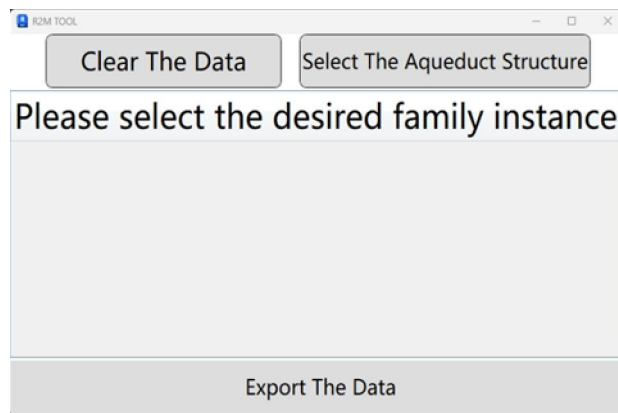

Fig. 4. R2M Operation Interface

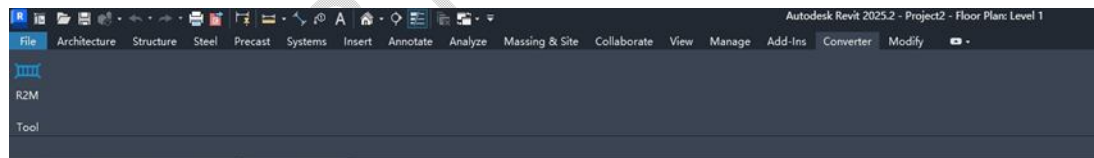

Fig. 5. Revit tab

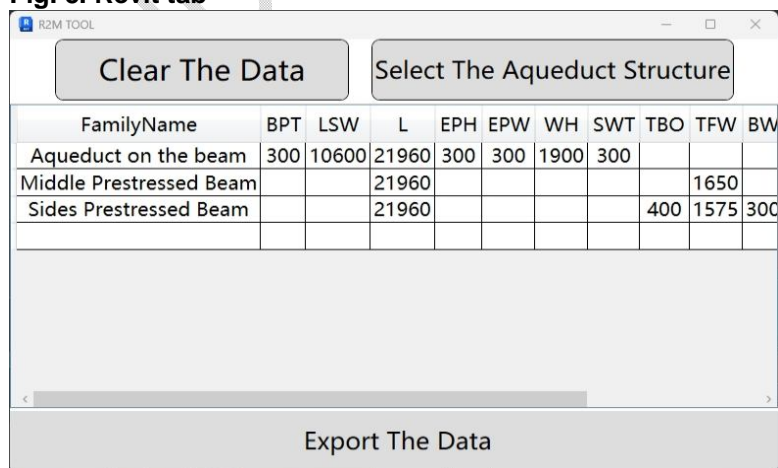

Fig. 6. Revit model data readout and export

Table 2 R2M preset header definitions

Header	Interpretation	Header	Interpretation
BPT	Bottom Plate Thickness	TBO	T-beam Block Outreach
LSW	Lower Slot Width	TFW	T-beam Flange Width
L	The span of the beam	BW	Block Width
EPH	Edge Protection Angle Height	BH	Block Height
EPW	Edge Protection Angle Width	FT	Flange Thickness
WH	Wall Leg Height	TW	T-beam Width
SWT	Side Wall Thickness	TWH	T-beam Web Height

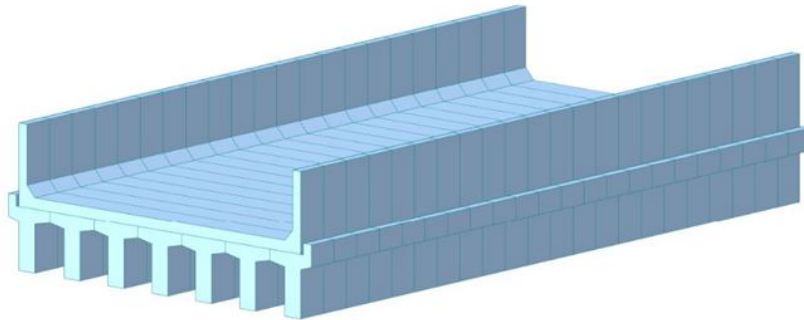

Fig. 7. Midas model of rectangular aqueduct superstructure

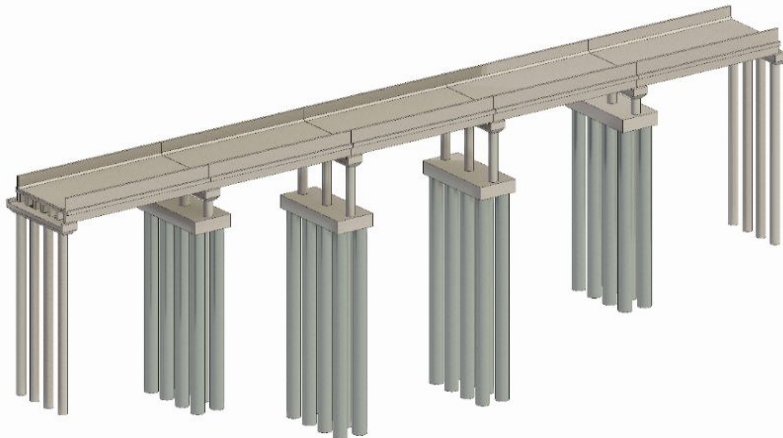

Fig. 8. Revit model of rectangular aqueduct superstructure

3. RESULTS AND DISCUSSION

To verify the feasibility and effectiveness of the proposed Revit-Midas model conversion method and procedure, a rectangular aqueduct superstructure from the South-to-North Water Diversion Project was selected as an example. The model represents a multi-beam prestressed rectangular aqueduct structure, with a longitudinal length of the aqueduct body is 110 meters, consisting of 5 spans, with a single span length of 22 meters. The aqueduct body is constructed using C50 prestressed concrete with a multi-beam structure, and the cross-section of the aqueduct body measures 10 meters in width and 2 meters in height. GPZ series basin-type rubber bearings are installed between the aqueduct body and the cap beam, with two sets provided at each end of the spans: one fixed and one movable. The R2M program was used to select a single span for model conversion, and Table 3 lists several characteristics of the selected model before and after conversion. The results

indicate that the geometric information conversion of the rectangular aqueduct superstructure model was very successful.

Table 3. Model transformation validation

Geometric feature	Revit model	Midas model	Conversion results
Number of nodes/pcs	184	184	success
Number of elements/pcs	176	176	success
Length of model/m	21.96	21.96	success
Symmetrical parts	Symmetrical	Symmetrical	success

Traditional modeling methods require a significant amount of time to manually input each section and complete the model in Midas, especially when it involves a considerable amount of repetitive work, leading to low efficiency. For instance, during the testing phase, manually establishing the model takes approximately 30 minutes, whereas the model obtained through the R2M conversion program can be established in just 2 minutes. Furthermore, since all geometric dimensions are extracted from the BIM model, the accuracy of the model is highly reliable.

To further verify the reliability of the computational results obtained from the proposed model conversion method, an identical model was manually established in Midas Civil. An analytical comparison was conducted between the two models under self-weight load conditions, with boundary conditions reflecting the actual situation by releasing the axial constraint at one end. The analysis primarily focuses on the aqueduct support beam structure, neglecting the contribution of the aqueduct bottom slab to the forces acting on the T-beams during the service stage, with the self-weight of the aqueduct considered as a secondary permanent load applied to the T-beams. The bridge finite element calculation software adopts the traffic industry standards for calculation verification by default, while parameters for the verification of hydraulic structures such as aqueducts must be manually adjusted in the program according to the relevant hydraulic industry standards[23]. The related parameters for concrete are provided in Table 4.

Table 4. C50 concrete material parameters

Elastic modulus E_c/Gpa	Poisson's ratio μ	Linear expansion coefficient $\alpha_1/10^{-5}^{\circ}C^{-1}$	bulk density $\gamma/kN \cdot m^{-3}$	Standard Value for Axial Compression f_{ck}/Mpa	Axial compressive design value f_c/Mpa
34.5	0.167	1.0	25.0	32.4	23.1

Figure 9 provides a detailed comparative analysis, illustrating the vertical displacement cloud diagrams for both the converted model and the manually created model within the Midas software environment. Upon examining the vertical displacements at each node for both models, it becomes evident that there is a high level of consistency between the two. This consistency is reflected in the similar patterns and values observed in the displacement diagrams, indicating that the converted model performs comparably to the manually crafted model in terms of vertical displacement calculations.

Figure 10 delves into a comparison of the stress cloud diagrams for the converted model and the manually created model in Midas. It can be seen from the results that the maximum stress values of the concrete obtained from the two calculation results occur at the same position, which are 6.1566 MPa and 6.0306 MPa. The relative error between these two values is calculated to be less than 3%, which is considered negligible for most engineering applications. These findings strongly suggest that the R2M conversion method, when compared to traditional manual modeling techniques, not only satisfies the stringent accuracy requirements essential for engineering projects but also offers substantial benefits.

By employing the R2M conversion method, design personnel can achieve significant time savings, thereby enhancing overall work efficiency.

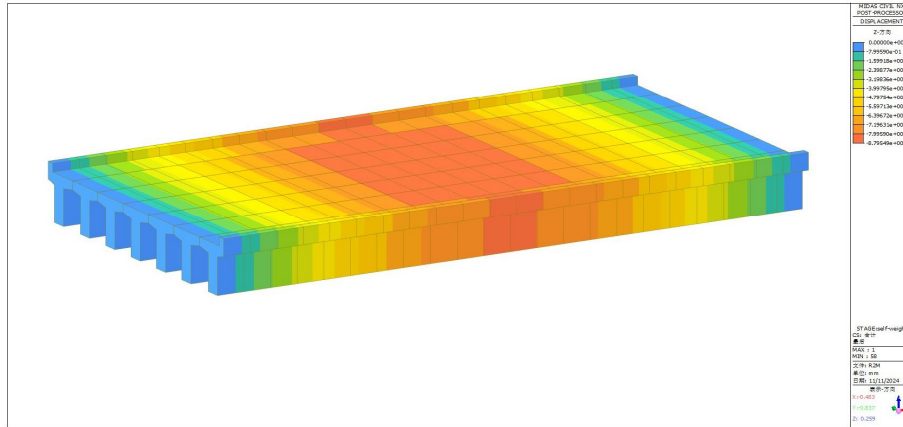

(a)

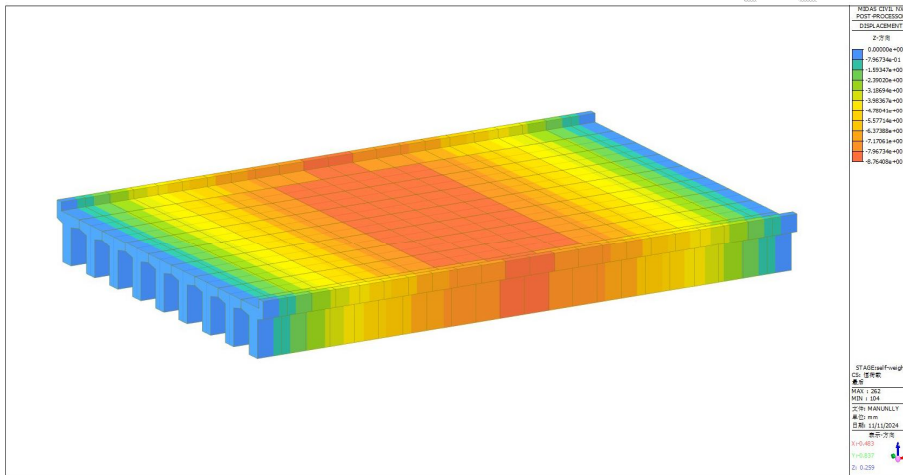

(b)

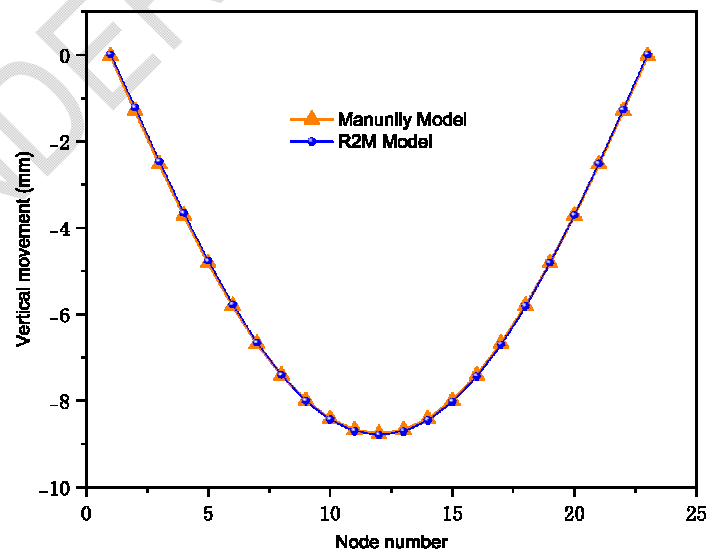

(c)

Fig. 9. Vertical displacement calculation results (a) R2M conversion model calculation results (b) Midas manual modelling calculation results (c) Model comparison

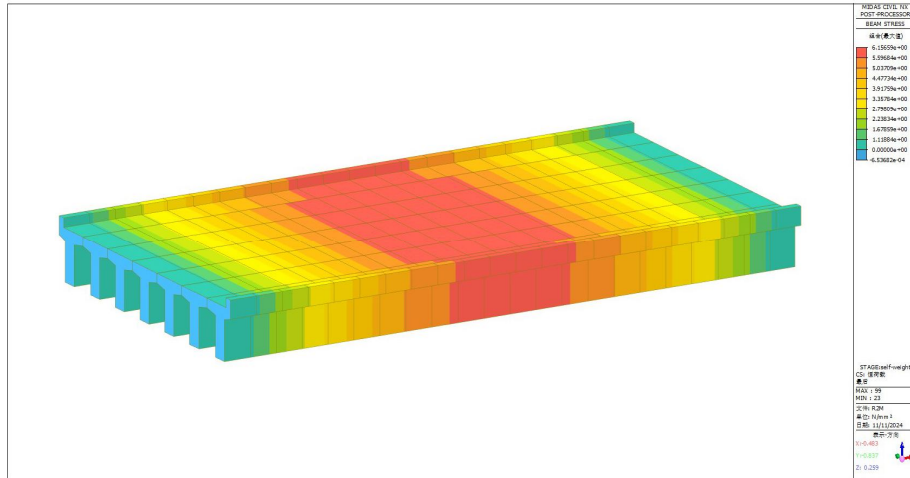

(a)

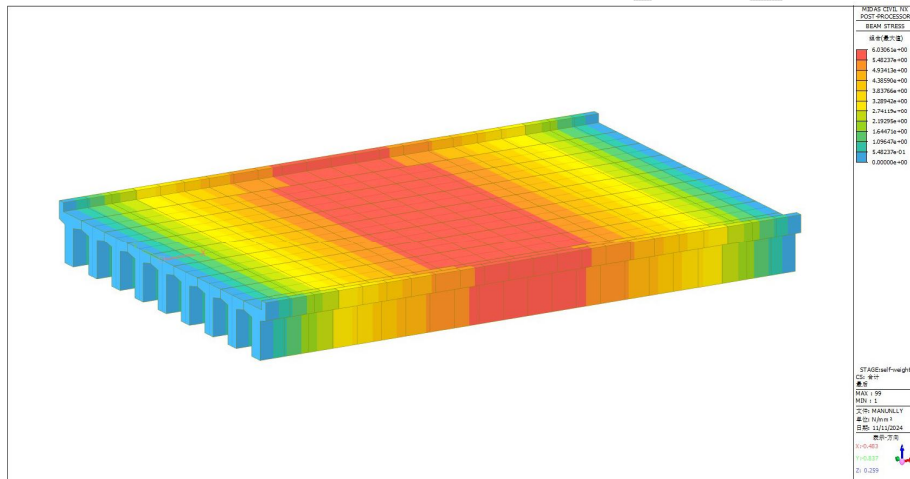

(b)

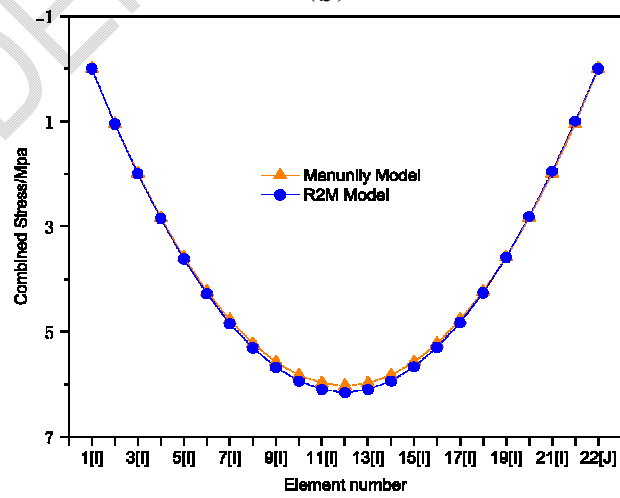

(c)

Fig. 10. Comprehensive stress calculation results (a) R2M conversion model calculation results (b) Midas manual modelling calculation results (c) Model comparison

4. CONCLUSION

This study proposes a model conversion framework that integrates the sophisticated modeling capabilities and secondary development features of Revit with the structural calculation and analysis capabilities of Midas Civil. It provides a detailed introduction to the principles of the M2R program for model conversion based on Revit, outlining the algorithms for information interaction, data processing, and the development of a conversion interface for the superstructure model of aqueducts from Revit to Midas. The main conclusions are as follows:

i. User-Friendly Operations with High Conversion Accuracy: By following the prompts in the WPF interface, users can select the desired Revit model and click the "Export The Data" button to create a backend task that generates the MCT file necessary for structural calculation modeling.

ii. Significantly Improved Modeling Efficiency: In the testing phase, for the same project, creating an identically precise Midas model has reduced the time from the previous 20-30 minutes to just 2 minutes, at least 90% of the time was saved. For larger models, the time savings may be even more substantial.

iii. Automation of Modeling from BIM to Computational Design: This innovative approach has effectively bridged the information gap between Midas calculation software and BIM models specifically for rectangular aqueduct structures, thereby significantly enhancing modeling efficiency. It has, to a certain extent, increased productivity and provides valuable insights into the application of BIM technology in the forward design of rectangular aqueduct structures.

iv. Improvements and Shortcomings: Although the model conversion program R2M was developed based on secondary development and integrated into Revit software, addressing the shortcomings of BIM technology in the analysis of hydraulic structures, the conversion strategy of BIM models needs to be adjusted for other structural forms to suit their corresponding characteristics. In the future, methods for acquiring and transmitting data such as loads, boundary conditions, and shrinkage creep during the model conversion process will be further improved, and a more comprehensive BIM-FEA model program will be developed to provide references for addressing issues such as information discontinuity and repetitive work during the engineering design phase of hydraulic projects.

Disclaimer (Artificial intelligence)

Option 1:

Author(s) hereby declare that NO generative AI technologies such as Large Language Models (ChatGPT, COPILOT, etc.) and text-to-image generators have been used during the writing or editing of this manuscript.

Option 2:

Author(s) hereby declare that generative AI technologies such as Large Language Models, etc. have been used during the writing or editing of manuscripts. This explanation will include the name, version, model, and source of the generative AI technology and as well as all input prompts provided to the generative AI technology

Details of the AI usage are given below:

- 1.
- 2.
- 3.

REFERENCES

1. Miettinen R, Paavola S. Beyond the BIM utopia: Approaches to the development and implementation of building information modeling. *Autom. Constr.* 2014,43,84-91.
2. Chen, LiJuan& Luo, Hanbin. A BIM-based construction quality management model and its applications. *Autom. Constr.* 2014, 46. 64–73.
3. Shim, Changsu& Yun, Nuri & Song, Hyunhye. Application of 3D Bridge Information Modeling to Design and Construction of Bridges. *Procedia Eng.* 2011. 14. 95-99.
4. Charehzehi A, Chai C, Md Yusof A, Chong H-Y, Loo SC. Building information modeling in construction conflict management. *Int. J. Eng. Bus. Manag.* 2017. 9,1.
5. Yinchen You, Yi Zheng, Xiaohui Chen, and Shadi Aljawarneh. 2022. Civil Engineering Simulation and Safety Detection of High-Rise Buildings Based on BIM. *Mob. Inf. Syst.* 2022 (2022). <https://doi.org/10.1155/2022/7600848>
6. Lu Q, Won J, Cheng JCP. A financial decision making framework for construction projects based on 5D Building Information Modeling (BIM). *Int. J. Project Manage.* 2016. 34(1), 3-21.
7. Hollands, J.; Korjenic, A. Evaluation and Planning Decision on Façade Greening Made Easy—Integration in BIM and Implementation of an Automated Design Process. *Sustainability* 2021, 13, 9387.
8. Yasser Yahya Al-Ashmori, Idris Othman, Yani Rahmawati, Y.H. Mugahed Amran, S.H. Abo Sabah, Aminu Darda'uRafindadi, Miljan Mikić. BIM benefits and its influence on the BIM implementation in Malaysia. *Ain Shams Eng. J.* 2020, 11, 1013-1019.
9. Jia, J., Gao, J., Wang, W., Ma, L., Li, J., Zhang, Z. An Automatic Generation Method of Finite Element Model Based on BIM and Ontology. *Buildings* 2022, 12, 1949.
10. Sacks R., Eastman C., Lee G., Teicholz P. *BIM Handbook: A Guide to Building Information Modeling for Owners, Designers, Engineers, Contractors, and Facility Managers* 3rd ed.; John Wiley & Sons: Hoboken, NJ, USA. 2018.
11. YepingTan, Yi Wu, Research on Revit-Ansys model conversion of continuum bridge based on dynamo. *Journal of InformationTechnologyin Civil Engineering and Architecture* 2023, 15, 44–48.
12. Carvalho, J.P.; Villaschi, F.S.; Bragança, L. Assessing Life Cycle Environmental and Economic Impacts of Building Construction Solutions with BIM. *Sustainability* 2021, 13, 8914.

13. Wang X, Huang Y, Zhao J and Duan L. Development and application of Revit-Abaqus model exchange interface. *Journal of Shanghai Jiaotong University* 2020. 54 135–143. Chinese.
14. Zhou H, He X and Leng X L. Development and application of a Revit-ANSYS model transformation interface. *IOP Conf. Ser.: Earth Environ. Sci.* 2021, 861 072058. Chinese.
15. Pingxiang He, Hao Wang, Yiming Zhang, Feiqiu Wang, Jianxiao Mao, Yishun Xie. Revit-Midas/Civil Model Conversion Methods and Applications. *Journal of Southeast University(Natural Science Edition)* 2021, 51 (05): 813-818. Chinese.
16. Li, Jian et al. A Revit-Midas/Civil conversion approach for bridge superstructures analysis. *Engineering Research Express* 6 2024, 10.1088/2631-8695/ad301b.
17. Zheng Tan. Application of MIDAS calculation software in hydraulic engineering. *Technology Wind*, 2023, (12): 72-74. Chinese.
18. Dingguo Zhu, Xiaotao DU, Yu Zhao. Cross-platform applications combining BIM and numerical simulation software. *Sci-Tech & Development of Enterprise*, 2024 1-4. Chinese.
19. Wei Zhang. Application of Midas Civil Software in the Structural Analysis of Shu Lu Trunk Drainage Tanks. *Jianghuai Water Resources Science and Technology*, 2021, (02): 4-5. Chinese.
20. Jacob M, Balakrishnan S D. Modal analysis of an RCC long span arch bridge using Midas Civil-A validation. *Mater. Today Proc.* 2022. 57, 460–463.
21. Guosheng Huan. *API Development Guide Autodesk Revit*. 1st ed.; China Water & Power Press: Beijing, China, 2016.
22. Yuanfeng Yang. *Construction Engineering BIM Innovation Depth Application BIM Software Development*, 1st ed.; China Architecture & Building Press: Beijing, China, 2016.
23. SL 191-2008. *Design Code for Hydraulic Concrete Structures*. CN-SL: Beijing, China, 2008.01.01.