

# Review Article

## Research Method for Rapid Layout of Bridge Models Based on BIM Technology

---

### ABSTRACT

Bridge engineering faces significant challenges and difficulties in applying BIM technology due to its complex structure, changes in component cross-sections, and terrain variations. In building construction projects, elevation and grid are commonly used as the coordinate reference system for buildings, which can help engineers accurately locate various components and parts of the building. However, in bridge engineering, due to the complex changes in road curves and terrain, traditional elevation and grid are no longer applicable in many cases. Therefore, how to achieve parameterized design of component models and rapid and accurate model construction in bridge engineering is an urgent problem that needs to be solved in the engineering field. This article compiles project information of bridge engineering into Excel and uses C # programming language combined with RevitAPI to extend the functionality of Revit, developing a plugin for rapid parametric modeling of bridge engineering based on "Revit+Excel". This plugin not only significantly improves the modeling efficiency of bridges, but also ensures modeling accuracy, thereby promoting the application of BIM technology in bridge engineering.

*Keywords: Bridge engineering, BIM technology, Parametric design, RevitAPI, Excel*

### 1. INTRODUCTION

In recent years, with the rapid development of information technology, BIM technology has played an increasingly important role in the field of construction engineering. As one of the mainstream BIM software, Revit's parameterization and visualization functions enable users to flexibly design model properties and visually present design effects. The greater advantage of Revit is the integration of various information from the design, construction, operation, and maintenance phases of a building project, enabling unified management, sharing, and collaboration of data. Revit itself has many powerful features, but it still provides users with the RevitAPI, which enables users to have a deep understanding of the underlying logic and internal mechanisms of Revit software, thus better utilizing the powerful features of Revit software. Therefore, users can also develop specific functions according to their needs to further improve work efficiency. Many scholars have conducted secondary development on Revit to meet specific needs. Wang [1] read the information from CAD drawings into Excel and organized and supplemented it. He used a designated plugin to read the data from Excel for automatic modeling, avoiding some repetitive modeling work. Hu[2] designed a conversion interface through Revit API, which enables direct conversion from BIM models to WebGIS models without the need for intermediate conversion formats such as IFC and OBJ. In order to compensate for the lack of stability calculation and structural analysis modules for complex hydraulic structures in Revit, Zhu [3] designed a set of calculation plugins for stability analysis of water gate retaining walls that are easy to operate, respond quickly, have high accuracy, and have good visualization effects. The plugins achieve high-precision and high-efficiency stability calculation, as well as high visualization and low operational difficulty human-machine interaction

functions. Deng [4] created a security management module based on Revit software through secondary development, which realizes the safety management of construction hazards based on BIM technology. It has been applied in practice and achieved excellent results. In order to solve the problem of low efficiency in traditional collision detection in BIM technology, Chen Xinyao [5] developed two types of plugins based on Revit API functions: hard collision and gap collision between components. The results of collision components were displayed in the view, and the practicality and stability of the plugin were verified through actual engineering. Chen [6] developed a BIM drawing system to address the low efficiency of current BIM software in drawing construction detailed drawings, which can improve the efficiency of drawing. Li [7] designed a plugin for matching rules and paths between Revit models and bills of quantities by analyzing the hierarchical structure of Revit models and bills of quantities, which laid the foundation for outputting bills of quantities on the Revit platform. Zhang [8] customized the development of Revit software and proposed a forward parameterized intelligent modeling method for aqueducts. This method realizes the design of structural parameters for aqueducts, simplifies cumbersome modeling steps, and improves design efficiency.

BIM technology is widely used in the field of building construction, but relatively less applied in the field of bridge engineering. The difficulty of applying BIM technology in bridge engineering lies in the wide variety of bridge components, the complexity of curved structures, and the difficulty of accurate modeling [9]. Many scholars have conducted research on the application difficulties of BIM technology in bridge engineering using the visual programming plugin Dynamo. Wang [10] proposed a modeling method using Dynamo driven Revit topology point element box section profile family, and used Python scripts to batch modify parameters during the modeling process, achieving rapid creation of BIM models for variable cross-section continuous box girder bridges. Bao [11] completed a complete cast-in-place continuous beam bridge design modeling method based on the "Revit+Dynamo" mode by organizing data and developing Dynamo program. Song [12] improved the efficiency of BIM parametric modeling of bridges by linking variable parameters of T-beam bridges in Excel through Dynamo. Although Dynamo is a powerful visual programming tool that can be quickly mastered by users without programming background, debugging scripts becomes difficult when the implementation of requirements becomes complex, making it difficult for users to find nodes that contradict their requirements. In addition, Dynamo's functionality is also limited by third-party libraries. Therefore, some scholars directly implement specific functions through the C# programming language and Revit API. Bai [13] used the C# programming language and Revit API to create BIM models of urban rail transit lines by intervals through parameter control methods. Du [14] used the C# programming language to integrate the functions of automatic modeling, construction simulation, and cost analysis of bridge engineering into the BIM core software.

This article takes a T-beam bridge as an example, first organizing the data information of bridge components into Excel, combining Revit with Excel, and based on the underlying logic of Revit API, abandoning the traditional positioning methods of elevation and axis network, using C# programming language to develop a plugin that can quickly create component models and complete the layout of the entire bridge.

## **2. DEVELOPMENT TOOLS AND PROCESSES**

As a widely used BIM software both domestically and internationally, Revit not only has powerful functions, but also provides a rich and extended Revit API [15-16], which can meet specific needs. The Revit API allows users to use C#, C++, VB, etc Programming with NET compatible languages. C# is an object-oriented programming language that is derived from C and C++ and eliminates the original complexity. The syntax of C# is simple and easy to

understand, making it easy to read and maintain code, and it is known for its powerful operational capabilities and innovative language features. The preferred language for NET development. Therefore, this article explores and develops using Revit API 2020 and C # programming language on the Visual Studio 2022 platform.

The first step is to set up the development environment. This design aims to enhance the interaction between users and Revit, so the project template selected when creating a new project in VS is based on WPF applications based on the .NET Framework provide a new multimedia interactive user interface [17-18]. Secondly, add "RevitAPI. dll" and "RevitAPIUI. dll" to the "References" section of the project [19-20], And add a library for writing user requirements, implement the "IExternalCommand" interface in this class, and then write code to implement the requirements in this interface. The specific process of setting up the development environment is shown in Figure 1.

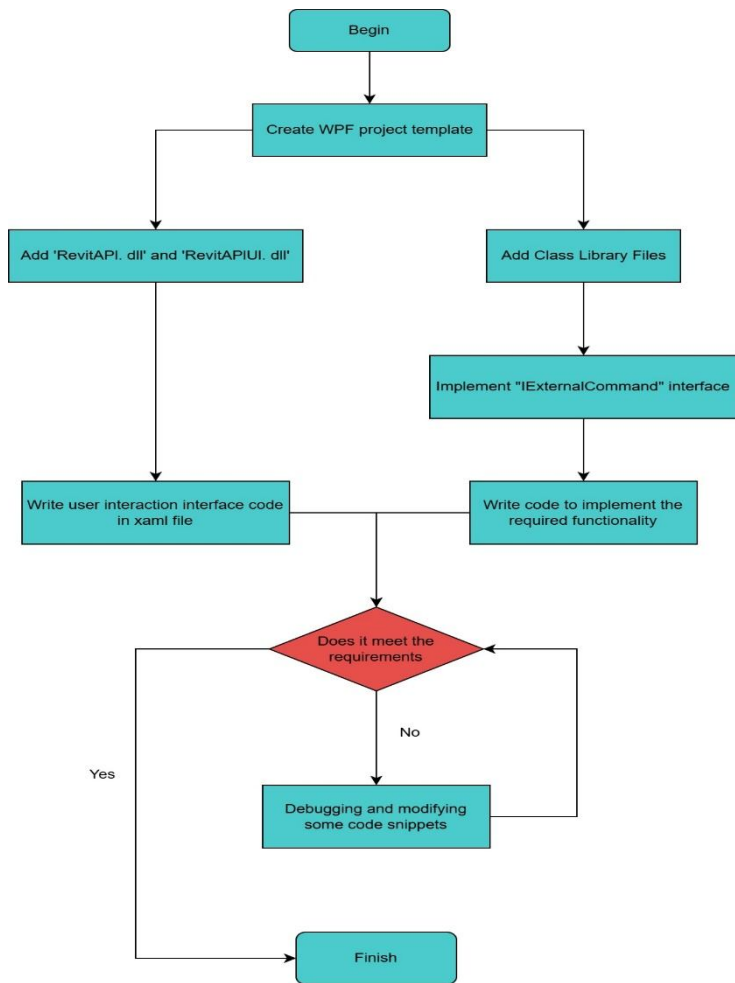

Fig. 1. Process diagram for setting up the development environment

### 3. PARAMETERIZED FAMILY LIBRARY OF BRIDGE COMPONENTS

The methods used to create parametric families in Revit software mainly include stretching, layout, rotation, fusion, layout fusion, hollow fusion, etc. This article takes the T-beam bridge as an example, and the bridge components that need to be created include pile foundations,

piers, tie beams, bent caps, T-beams, etc. The above components are created as parameterized families for batch parameter modification in the future.

The cross-section of the pile foundation created this time is circular and is stretched. The template file selected for creating the pile foundation is "Metric Structural Foundation", Draw the profile on the view of "reference elevation", add dimensions and create instance parameters for the diameter of the circular profile, and name it "PileDiameter". Next, adjust to the elevation view, create a reference plane, align and lock the top surface of the pile foundation with this reference plane, align and lock the bottom surface of the pile foundation with the "Reference Elevation", and add an instance parameter of "PileLength" to it. The example parameters of the diameter and length of the pile foundation are shown in Figure 2. The process of creating bridge piers is similar to that of pile foundations, and will not be repeated here.

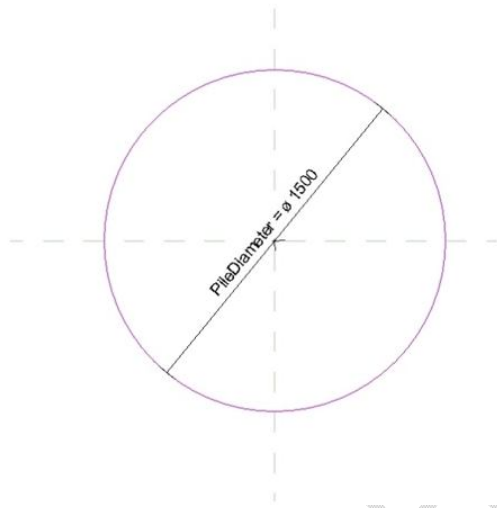

**Fig.2.Create instance parameters for pile foundation**

The template file selected when creating the tie beam, bent cap, and T-beam is "Metric Structural Frame - Beam and Support". The parametric families of these three components are also created by stretching. The cross-sections and parameters of the parametric families of the tie beam and T-beam during stretching are shown in Figure 3.

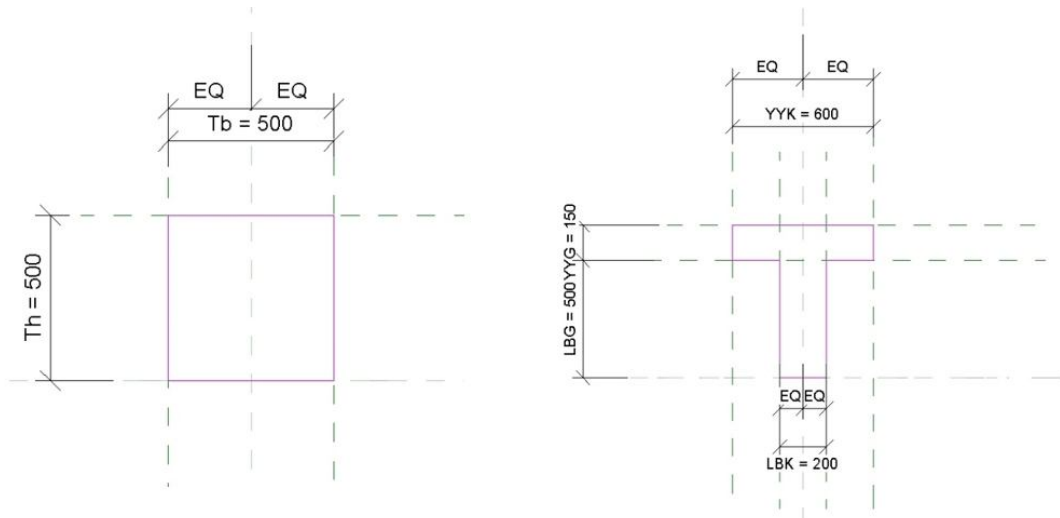

**Fig.3. Sections and parameters of tie beam and T-beam**

Both the tie beam and T-beam are created by stretching the left view of the elevation as the working plane. Due to the special nature of the cover beam, the working plane used for stretching the cover beam is the front view. Therefore, the tie beam and T-beam are stretched left and right, while the bent cap is stretched back and forth. The cross-section and parameters of the beam under tension are shown in Figure 4.

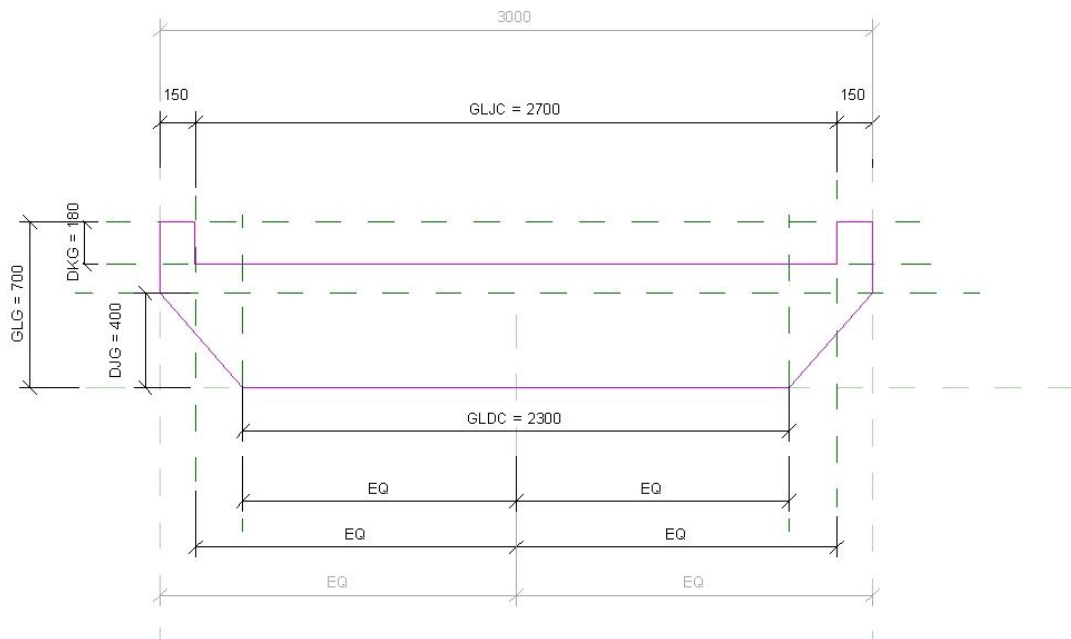

**Fig.4. Section and parameters of bent cap**

The above explains the creation method of components, and by controlling the stretching length, a parameterized component family library can be created. The 3D model of the above components is shown in Figure 5

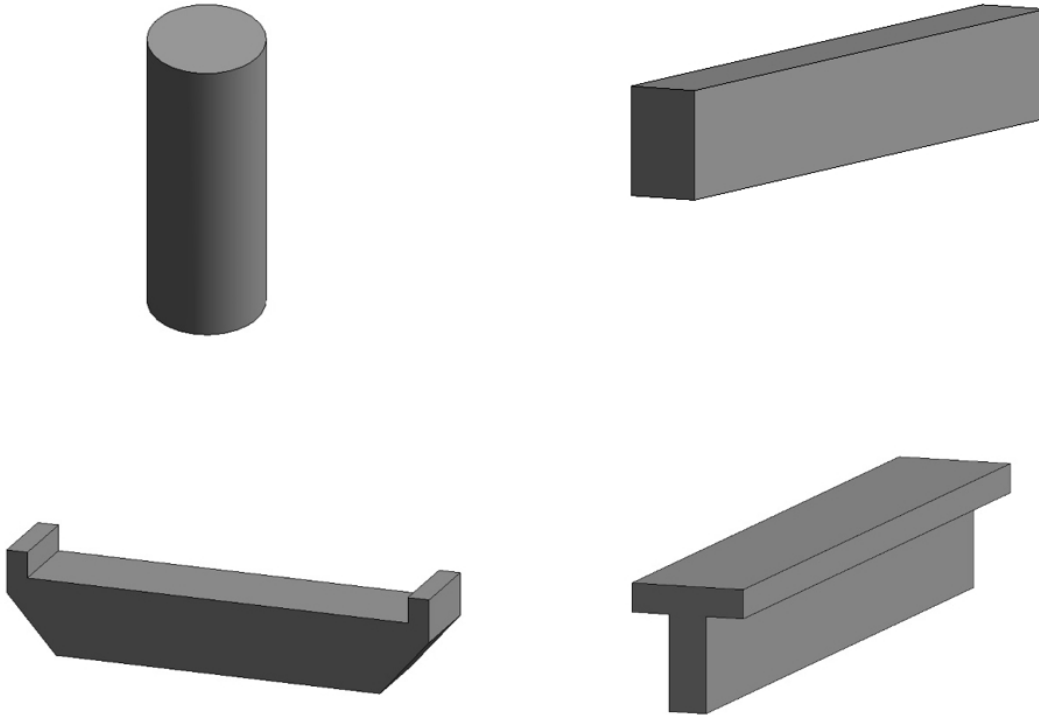

**Fig.5.Three dimensional model of bridge components**

#### **4. IMPLEMENTATION METHOD OF BRIDGE MODEL LAYOUT**

In building construction projects, elevation is usually used to determine the height position of various components inside and outside the building. By setting different elevations, architects and engineers can determine the overall elevation layout of the building, including the height and position of components such as floors, walls, columns, etc., to ensure the verticality and levelness of the building, as well as to meet design requirements and specifications. Grid can help architects divide building structures into different parts and areas, facilitating the positioning and design of the positions and dimensions of various components. The grid can also serve as a reference line to help maintain the design efficiency and quality of building projects by utilizing elevation and grid reasonably, ensuring that buildings meet design requirements and specifications. The symmetry and accuracy of the structure ensure the overall layout and structural stability of the building.

In bridge engineering, the complex terrain can lead to different elevations between components, and because the bridge is a "linear" building, it will create a large number of grids along the route design line, making the operation more cumbersome. The bridge is a linear engineering, which involves many flat curve elements and is difficult to model. In order to reduce the modeling difficulty of prefabricated T-shaped beam bridge and improve the modeling efficiency and accuracy of prefabricated T-shaped beam bridge, the modeling

efficiency of prefabricated T-shaped beam bridge is very high. This article organizes the coordinate information of components into Excel and designs a program for Revit to automatically read the data in Excel and quickly create a 3D model of the bridge.

#### 4.1 Organize Excel data

To achieve the above functions, in addition to adding the dynamic link libraries "RevitAPI. dll" and "RevitAPIUI. dll" to the project template created in VS, it is also necessary to add a "NUGET" package, which includes a dynamic link library called "EPPLUS". EPPLUS is a popular open source library that enables the creation and editing of Excel files, reading and writing of Excel file data. It can meet various functions of processing Excel files in C # and enable Revit to read data from Excel at the underlying level.

Among the numerous components in bridge engineering, this article divides them into "point components" and "linear components". "Point components" include pile foundations and bridge piers, while "linear

components" include tie beams, bent caps, and T-beams.

For the data of "point type components", taking pile foundation as an example, the data that needs to be organized includes the spatial coordinates of the center of the pile foundation surface and the size parameters of the pile foundation, these data should be unified and organized into one Excel file. And input "X", "Y", "Z", "PileDiameter", "PileLength" as the header of each column for columns 1-5 in the first row. If there are other attribute parameters that need to be modified, they can be added to the list in Excel. The data organization template for pile foundation is shown in Figure 5.

	A	B	C	D	E
1	X	Y	Z	PileLength	PileDiameter
2					
3					
4					
5					
6					
7					

**Fig.6. Data template for "point components"**

The drawing method of "linear components" is based on line positioning, so it is necessary to organize the coordinates of the two endpoints of the component, input these two endpoint coordinates and size parameters into Excel. Taking T-beam as an example, the data sorting template for T-beam is shown in Figure 6. (X1, Y1, Z1) are the starting coordinates, and (X2, Y2, Z2) are the ending coordinates. These two coordinates can not only control the position of the component, but also the length of the component, YYK, YYG, LBG, LBK correspond to the cross-sectional parameters that control the T-beam.

	A	B	C	D	E	F	G	H	I	J
1	X1	Y1	Z1	X2	Y2	Z2	YYK	YYG	LBG	LBK
2										
3										
4										
5										
6										
7										

**Fig.7.Data template for " linear components "**

In VS, the reading of data information for each component is done through two classes. Taking pile foundation as an example. Firstly, create the "Pile" class, which contains five attributes: the positioning information of the pile foundation "X, Y, Z", the attribute information of the pile foundation "PileLength", and "PileDiameter"; We also created the "ExcelReader" class, which contains a static method called "ReadPileParameter". This method mainly obtains the worksheet and its row and column numbers based on the file path of Excel, reads data from Excel and returns a list containing the 'Pile' object. The specific execution process of the "ReadPileParameter" method is shown in Figure 7.

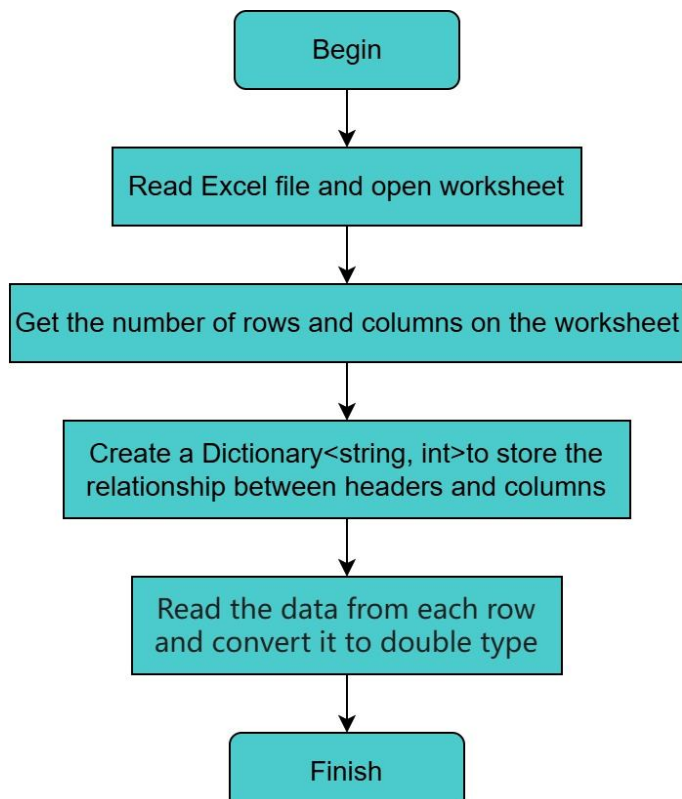

**Fig.8.The execution process of the static method "ReadPileParameter "**

#### 4.1 Layout of Bridge Models

After completing the above tasks, the next step is to load the family types of the bridge components into the Revit project. When creating family instances for pile foundations and bridge piers, both components are positioned using reference points. The method chosen when creating a family instance is `public FamilyInstanceNewFamilyInstance (DB.XYZ`

location, DB.FamilySymbol symbol, StructuralTypestructuralType);This method requires three parameters, namely the placement point of the family instance, the family type, and the structure type.Through the data processing in the previous section, first collect the X, Y, and Z attributes in the "Pile" class, create the positioning points of the pile foundation, and then create a family instance of the pile foundation. This is how "pointcomponents" operate.The method used for creating family instances based on line positioning is public FamilyInstanceNewFamilyInstance (Line Line, DB. FamilySymbol symbol, View specView),this method also requires three parameters, namely the placement line of the family instance, the family type, and the 2D view.Here, we still create a baseline for the start and end coordinates by calling the properties of the "class" that stores data information for the corresponding component, and call the above method to create a family instance of the "linear component".

The user interface for creating pile foundation instances is shown in Figure 8, and the user interface for creating T-beam instances is shown in Figure 9.

MainWindow

FamilyTypeName: Pile    Name1: PileLength    Name2: PileDiameter

SelectExcelFile: C:\Users\HASEE\Desktop\PileDataSheet.xlsx    Browse...

SelectFamilyFile: C:\Users\HASEE\Desktop\Pile.rfa    Browse...

Confirm

**Fig.9.**User interface for creating pile foundation instances (point component)

MainWindow

FamilyTypeName: T-Beam

Name1: YYK

Name2: YYG

Name3: LBG

Name4: LBK

SelectExcelFile: C:\Users\HASEE\Desktop\T-BeamDataSheet.xlsx

SelectFamilyFile: C:\Users\HASEE\Desktop\T-Beam.rvt

Confirm

**Fig.10.User interface for creating T-beam instances (linear component)**

Figure 10 shows a simplified model of a T-beam bridge, mainly to demonstrate the "point component" and "linear component" models, without involving other components such as guardrails and bridge deck paving. The feasibility of applying the design concept in bridge engineering can be demonstrated through the model of this T-beam bridge.



**Fig.11.Construction of Bridge Component Models**

## 5. CONCLUSION

The Revit API enables users to develop customized plugins based on the underlying logic and internal mechanisms of Revit software through programming, enriching the functionality of Revit software and further improving work efficiency and accuracy. This article organizes and stores the data information of bridge components through Excel, and creates a representative parametric family library of bridge components. A program that can read data from Excel is designed and attached to Revit to meet the requirements of batch modification of bridge component parameters and rapid deployment of bridge models. This "Revit+Excel" plugin successfully extends the functionality of Revit through the C# programming language and WPF application, and validates the efficiency and accuracy of this plugin through a simple T-beam bridge model. It abandons the traditional positioning methods of elevation and grid, effectively solves the challenges and difficulties faced by bridge engineering in BIM technology application, and promotes the application and development of BIM technology in the field of bridge engineering.

## REFERENCES

1. Wang, J.Z., Wang, X.Y. Research on rapid mold flipping technology from AUTOCAD to REVIT through secondary development implementation. *Information Technology in Civil and Architectural Engineering*, 2015,7(03):111-115.
2. Hu, X.K., Cheng, J.T., Yang, D. Research on BIM+WebGIS Fusion Application Based on Revit Secondary Development. *Journal of Central South University (Natural Science Edition)*, 2021,52(11):3930-3942.
3. Zhu, Z.Y., Niu, Z.W., Zhang, Y. Application of Revit Secondary Development in the Design of Retaining Walls for Sluice Projects. *People's Yangtze River*, 2021, 52 (02): 117-121.
4. Deng, L.N., Huang, X.X., Peng, L. Research and Application of Construction Hazard Safety Management Platform Based on Revit Secondary Development. *Journal of Guangxi University of Science and Technology*, 2018, 29 (01): 106-112.
5. Cheng, X.Y., Wang, I. Secondary development of collision detection in electromechanical engineering based on Revit. *Building Structure*, 2021,51 (S2): 1271-1276.
6. Chen, J., Yu, F.Q., Yi, S.K. Design and Development of BIM based Construction Deepening Automatic Drawing System. *Journal of Graphic Science*, 2023, 44 (04): 801-809.
7. L, J., Wang, L., Zhang, R.Q. Research on Secondary Development Based on Revit Model and Inventory Mapping. *Journal of Beijing Jianzhu University*, 2021,37 (04): 9-18.
8. Zhang, Y., Jiang, G.H., Tang, S.Y. A Forward Parameterized Intelligent Modeling Method for Aqueduct Based on Revit Secondary Development. *Hydroelectric Energy Science*, 2024, 42 (03): 137-141.
9. Zhao, Y.Y., Peng, C., Zhang, C.C. Application of BIM Technology in Fuzhou Xiamen High speed Railway Bridge. *World Bridge*, 2020,48 (S1): 106-112.
10. Wang, X., Tian, S.Z. Research on BIM modeling method of variable cross-section continuous beam bridge based on Dynamo. *Journal of Suzhou University of Science and Technology (Engineering and Technology Edition)*, 2021,34 (01): 23-28.
11. Bao, D.X., Yan, X.J., Zhang, T. Design and modeling of cast-in-place continuous beam bridge based on "Revit+Dynamo" mode. *Civil and Architectural Engineering Information Technology*, 2020,12 (05): 7-13.
12. Song, X.F. Research on a parametric modeling method for prefabricated T-shaped beam bridges based on Revit+Dynamo. *Highway*, 2023, 68 (12): 126-129.
13. Bai, J.J., Lv, X.K., Sun, P.P. Rapid modeling method for urban rail transit lines based on Building Information Modeling (BIM). *Urban Rail Transit Research*, 2019,22 (08): 170-173.

14. Du, D.R., Wang, L.T. Application of BIM Technology Based on Revit in Bridge Engineering. *Construction Technology*, 2019,48 (S1): 304-307.
15. Zhu, Z.Y. Application of BIM software secondary development technology in bridge reinforcement design. Kunming University of Science and Technology, 2019.
16. Cai, L., Chen, H.J., Liu, X.S. Exploration into the Development of BIM Plugin Platform. *Modern Information Technology*, 2022,6 (14): 119-122+125.
17. Yang, T.W., Xiao, C.H., Luo, J.Z. Development of a BIM based auxiliary system for forward design of conventional bridges. *Journal of Chengdu University (Natural Science Edition)*, 2021, 40 (02): 219-222.
18. Hu, Jin., Liu, H.X., Bao, Z.D. Research on Parameter Modeling and Application of Culvert and Sluice Engineering Based on Revit Secondary Development. *Hydroelectric Energy Science*, 2023, 41 (12): 211-214+194.
19. L, Y., Cheng, H.Y., D, H. Secondary development of prefabricated component library and parametric modeling based on C#. *Civil and Architectural Engineering Information Technology*, 2023, 15 (06): 101-105.
20. Wang, X.Y. Parametric design of pile foundation based on RevitAPI. Dalian University of Technology, 2020.