

Original Research Article

Genetic Characterisation and Molecular Phylogeny of **Mosquito** *Aedes Vittatus* Based on COI Gene from Bhawanipatna, Kalahandi, Odisha, India

ABSTRACT

Introduction

Aedes vittatus is common throughout India and breeds in a variety of locations, including tree holes, cement tanks, rock pools, abandoned containers close to residential areas, and marsh pools. The invasive mosquito species *Aedes vittatus* has expanded its range across Africa, Asia, Latin America, and Europe. Mosquito species have been successfully identified by characterizing a portion of the cytochrome c oxidase subunit 1 (cox1) gene, particularly in light of the difficulty in differentiating mosquito larvae and the scarcity of qualified taxonomists.

Objective

The current study was designed for molecular **characterisation** of the *Aedes vittatus* mosquitoes collected from all parts of Bhawanipatna based on mitochondrial COI to provide a wider understanding of the phylogenetic relationships of *Aedes vittatus* mosquitoes that exist throughout India. The genetic relatedness between India mosquitoes and those reported from other parts of the world was also investigated.

Material and Methods

The collection of data was made from different locations of Bhawanipatna Municipal Corporation, the headquarter of the district of Kalahandi, Bhawanipatna is located at 19.9°N 83.17°E. Adult *Aedes* mosquitoes were surveyed weekly from the selected human dwelling, both inside and outside the house or premises of Bhawanipatna Municipal area from **month June 2024** to **October** 2024. Adult mosquitoes were collected with the help of a manual aspirator tube and a torch light. DNA was isolated from the provided culture. Quality was evaluated on 1.8% Agarose Gel; a single band of high-molecular weight DNA has been observed. The consensus sequence was generated for each sample using BioEdit version 6.0.7 and were searched over the **GenBank** database using Basic Local Alignment Search Tool (BLAST) against the *Aedes vittatus* genomes in NCBI, **GenBank**. The complete sequences were deposited in **GenBank** with accession no. PQ477920.1

Conclusion

Aedes vittatus vector might be introduced to Kalahandi, Odisha from neighbouring states. The presence of this competent vector is most probably a risk of transmission of arboviruses such as Dengue fever, Yellow fever, West Nile virus, Zika virus and Chikungunya virus in this area.

Key Words: *Aedes vittatus*, Molecular Characterisation, Bhawanipatna, Odisha, COI

1. INTRODUCTION

According to Weaver et al. (2018) and Sudeep et al. (2017), *Aedes* (Fredwardsius) mosquitoes are the main carriers of several Mosquito-Borne Diseases (MBDs), such as Dengue fever (DF), Yellow fever (YF), Chikungunya (CHIKV) and the Zika virus [1, 2]. In recent decades, the burden of these Aedes-Borne Diseases (ABDs) has increased dramatically on a global scale. This increase is partly explained by the mosquitoes' improved ability to transmit diseases due to their increasing tolerance to different pesticides and resilience to environmental stressors. Interestingly, there are notable variances in adaptive genetic variants across *Aedes* mosquito populations from various geographic areas. Because genetic analysis of local mosquito populations can provide important insights into their genetic composition, propensity for disease transmission, stability over time and other pertinent aspects, effective control strategies are becoming more and more reliant on this method. Thus, genetic analysis of local mosquito populations is becoming more and more important for effective control measures because it can provide important information about the mosquitoes' genetic makeup, potential for disease transmission, stability over time and other factors related to disease spread, like vector migration between regions [3].

Other *Aedes* species may also aid in the spread of arboviruses because of their similar vector requirements, in addition to the well-known *Aedes aegypti* and *Aedes albopictus*. Particularly concerning are species like *Aedes japonicus*, *Aedes vexans* and *Aedes vittatus*, which have shown vector competence for a number of arboviruses, including the Dengue, Chikungunya and Zika viruses [4]. *Ae. vittatus* (Bigot, 1861) is common throughout India and breeds in a variety of locations, including tree holes, cement tanks, rock pools, abandoned containers close to residential areas and marsh pools [5].

The invasive mosquito species *Ae. vittatus* has expanded its range across Africa, Asia, Latin America and Europe [2, 6, 7], known for its preference for feeding on humans, *Ae. vittatus* is a highly anthropophilic mosquito that thrives in environments close to human residences (peridomestic) as well as in forested areas (sylvatic)[8]. Mosquito species have been successfully identified by characterising a portion of the cytochrome c oxidase subunit 1 (cox1) gene, particularly in light of the difficulty in differentiating mosquito larvae and the scarcity of qualified taxonomists [9, 10, 11]. However, this approach relies on prior genetic data for each species [12]. This presents a notable limitation for *Aedes* mosquitoes, as genetic data is lacking for most Indian species within this genus, despite their role in transmitting pathogens [13, 14].

Hence, the current study was designed for molecular characterisation of the *Ae. vittatus* mosquitoes collected from all parts of Bhawanipatna based on mitochondrial COI to provide a wider understanding of the phylogenetic relationships of *Ae. vittatus* mosquitoes that exist throughout India. The genetic relatedness between India mosquitoes and those reported from other parts of the world was also investigated.

2. MATERIALS AND METHODS

2.1 STUDY LOCATION

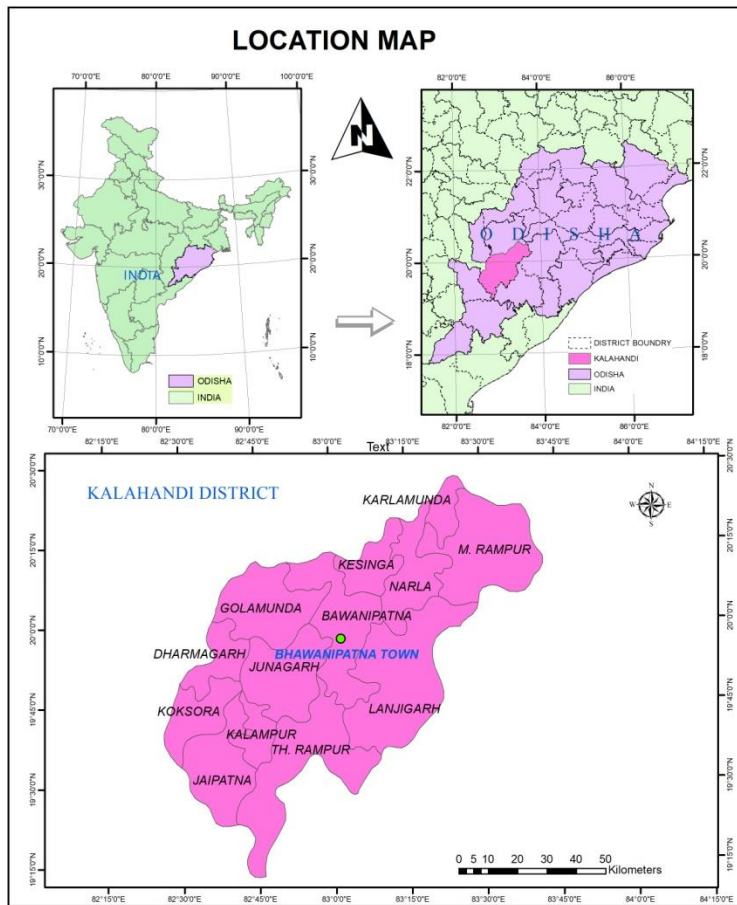

Figure 1: Map showing study area at Bhawanipatna in Kalahandi district of Odisha

The collection of data was made from different locations of Bhawanipatna Municipal Corporation, the headquarter of the district of Kalahandi, Bhawanipatna is located at 19.9°N and 83.17°E (Fig. 1), has a tropical wet and dry climate with annual average rainfall about 1300mm. The municipality has a population of 69,045 of which 35,506 are males while 33,539 are females residing in around 16,500 houses as per a report released by census India 2011.

2.2 SAMPLE COLLECTION

Adult Collection: Adult *Aedes* mosquitoes were surveyed weakly from the selected human dwelling, both inside and outside the house or premises of Bhawanipatna Municipal area from **month June 2024 to October 2024**. Adult mosquitoes were collected with the help of a manual aspirator tube and a torch light [15]. Immediately after collection, the mosquitoes were transferred into test tubes at the rate of 3 - 4 mosquitoes per tube. The date, place and time of collection were marked on each test tube. The mosquitoes were anesthetized and identified under a binocular stereo zoom microscope in the laboratory-based on the standard morphological keys [16]. **During the study hour, 286 *Aedes* mosquitoes in total were collected, of which 198 were female and 88 were male. However, 126 *Ae. albopictus*, 45 *Ae. aegypti*, and 27 *Ae. vittatus* were found among the 198 female *Aedes*. Similarly, of the 88 male *Aedes*, 19 were *Ae. vittatus*, 50 were *Ae. albopictus*, and 29 were *Ae. aegypti*.**

Larval Collection: Weekly Larval collections were made at random from indoor (earthen pot, cement tank, plastic container, flower pot, and plastic bucket etc.) and outdoor (cement tank, tree hole, coconut shell, metal drum, plant pot, plastic container, discarded tire, etc.) breeding sites. The location (indoor or outdoor), date and time, type of habitat and the number of larvae collected were recorded. The immature stages were collected with the help of a glass dropper and transferred to the laboratory in plastic containers, for development into mature stage and identification of mosquito at the species level.

2.3 MORPHOLOGICAL IDENTIFICATION

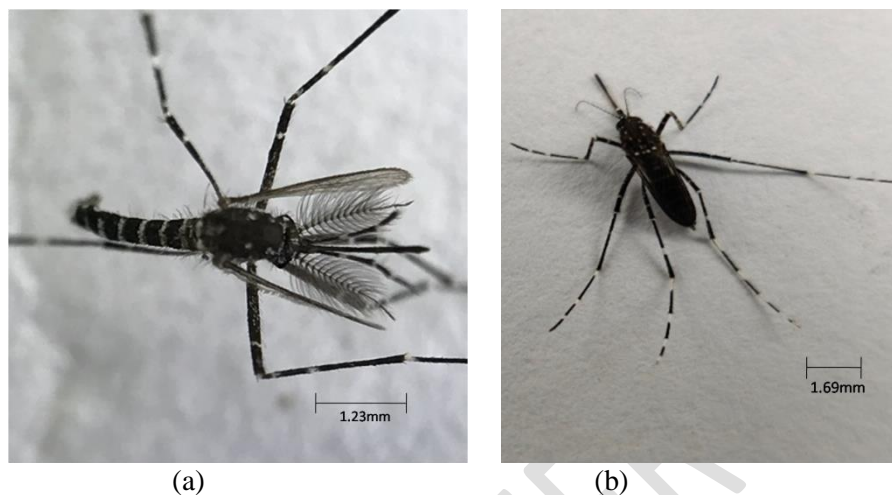

Figure 2: (a) *Aedes vittatus* (Male) and (b) *Aedes vittatus* (Female)

The larvae collected from different sampling sites were identified using morphological characteristics such as comb scale and pecten teeth, and the adults reared from larvae were identified using standard keys [16]. The important diagnostic characteristics to confirm the occurrence of *Ae. vittatus* specimens from the sampling location. The mosquito specimens were identified as *Ae. vittatus* and differentiated from other found *Aedes* mosquitoes by the following morphological characteristics. The presence of narrow dark scales and three pairs of small round white spots distributed along the dorso-central area of the scutum (Fig. 2). The identified *Aedes* specimens with dark tibiae, each with a subbasal white spot and a white band at about basal 0.33 on fore- and mid- and at about 0.50 on hind-tibia (Fig. 2). In addition, the mosquito specimens have a distinct white band on the proboscis [17].

2.4 PCR AMPLIFICATION OF COI PARTIAL DNA SEQUENCE AND SEQUENCING

2.4.1 Isolation

We used Hi-PurA Insect DNA Purification Kit Catalog No. MB569-20PR from Hi-Media for the DNA Isolation from *Aedes vittatus*.

2.4.2 Agarose gel electrophoresis

The amplified DNA was separated by electrophoresis in 0.8% agarose gel run in 1× TAE buffer at 50V for 30 to 45 minutes until DNA fragments were migrated well. The gel was photographed on gel documentation system by using iBright™ CL750 Imaging System model.

2.4.3 PCR Amplification

Isolated DNA was amplified with mitochondrial cytochrome c oxidase subunit I (COI) genes Specific Primer (**LCO 1490 & HCO 2148**) using Veriti® 96 well Thermal Cycler. A single discrete PCR amplicon band of ~700 bp was observed (Fig. 3). The PCR amplicon was bead purified and further subjected to Sanger Sequencing.

2.4.4 Sequencing

Bi-directional DNA sequencing reaction of PCR amplicon was carried out with **LCO 1490- TCC GTA GGT GAA CCT GC GG & HCO 2148- TCC TCC GCT TAT TGA TAT GC** primers using BDT v3.1 Cycle sequencing kit on ABI 3500Dx Genetic Analyzer.

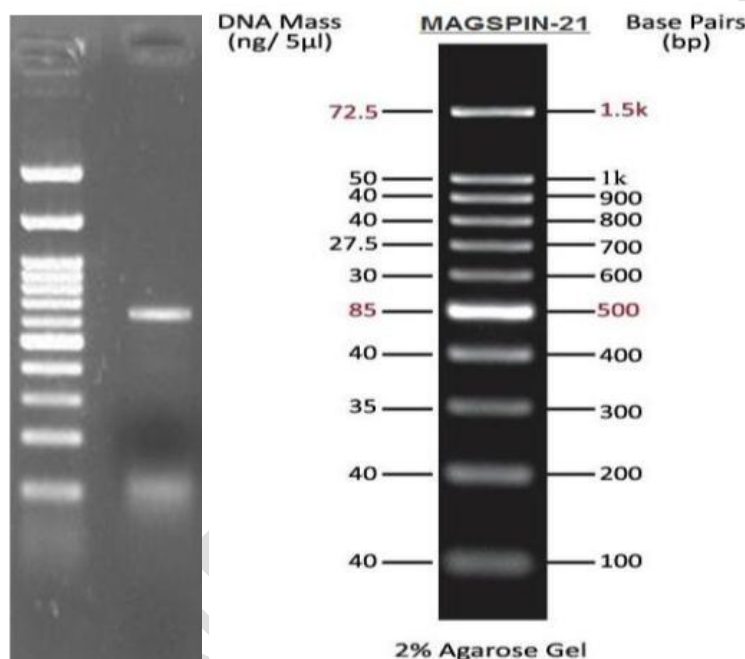

Figure 3: Agarose gel (1.8%) showing single 700 bp of mitochondrial cytochrome c oxidase subunit I amplicon.

2.5 DATA ANALYSIS

The consensus sequence was generated for each sample using BioEdit version 6.0.7 and were searched over the GenBank database using Basic Local Alignment Search Tool (BLAST) against the *Ae. vittatus* genomes in GenBank (NCBI WEB SITE). The complete sequences were deposited in GenBank with accession no. PQ477920.1. The mt COI sequence of *Ae. vittatus* (our isolated strain **KSP02**) were compared with the whole world samples of gene COI of *Aedes* species found from other

countries (Fig. 4); further it also compared with the COI gene sequence of Indian *Ae. vittatus* (Fig. 5) using Multiple Sequence Alignment (MSA) based on the sequences available in NCBI GenBank..

The evolutionary history was inferred using the Neighbor-Joining method [18]. Phylogenetic trees were built using maximum likelihood method (with 1000 bootstraps) with Kimura a cluster containing >50% bootstrap support, was considered significant. The evolutionary distances were computed using the Maximum Composite Likelihood method [19] and were in the units of the number of base substitutions per site. This analysis involved 14 nucleotide sequences. Codon positions included were 1st+2nd+3rd+noncoding. All ambiguous positions were removed for each sequence pair (pairwise deletion option). Evolutionary analyses were conducted in MEGA X [20].

3. RESULT

The **KSP02** isolate from Bhawanipatna, Kalahandi, matched the sequences that had previously been added to the NCBI GenBank (Fig. 4) from all around the world. *Ae. vittatus* was identified as our isolated strain, and it exhibited a high degree of similarity (99.85%) with accession number MK491498.1, followed by 99.70%, 99.54%, 99.39%, and so on with other strain sequences from all across the world that had previously been deposited in the NCBI GenBank matched the **KSP02**-identified strain from Bhawanipatna, Kalahandi (Fig. 4). Additionally, the COI sequences of *Ae. vittatus* from India that were already in the NCBI GenBank agree with our isolated strain **KSP02** from Bhawanipatna. The **KSP02** isolate was most similar to the Kerala03 strain (accession number MK491498.1) (99.85%), followed by the Kerala02 strain (accession number MT858330.1) (99.81%), the Kolkata strain (accession number PQ483326.1) (99.77%), and so on. However, the isolated strain **KSP02** was the least similar (99.03%) to Kolkata strain (accession number PQ483326.1). However, the Indian *Ae. vittatus* isolates from Coimbatore and Pondicherry, with accession number KR872404.1 and AY834246.1, respectively, shared the least amount of similarity (99.03%) with the **KSP02** separated strain.

Description	Scientific Name	Max Score	Total Score	Query Cover	E value	Per. Ident	Acc. Len	Accession
<input checked="" type="checkbox"/> Aedes vittatus cytochrome oxidase subunit I gene, partial cds: mitochondrial	Aedes vittatus	1247	1247	100%	0.0	99.85%	679	MK491498.1
<input checked="" type="checkbox"/> Aedes vittatus voucher NP2_16S cytochrome c oxidase subunit I (COX1) gene, partial cds: mitochondrial	Aedes vittatus	1223	1223	99%	0.0	99.11%	676	OL348176.1
<input checked="" type="checkbox"/> Aedes vittatus voucher NP2_15S cytochrome c oxidase subunit I (COX1) gene, partial cds: mitochondrial	Aedes vittatus	1221	1221	99%	0.0	99.26%	679	OL348175.1
<input checked="" type="checkbox"/> Aedes vittatus voucher NP2_14S cytochrome c oxidase subunit I (COX1) gene, partial cds: mitochondrial	Aedes vittatus	1210	1210	97%	0.0	99.70%	664	OL348174.1
<input checked="" type="checkbox"/> Aedes vittatus voucher SL/M21 cytochrome c oxidase subunit 1 (COI) gene, partial cds: mitochondrial	Aedes vittatus	1208	1208	96%	0.0	99.85%	657	MH330197.1
<input checked="" type="checkbox"/> Aedes cogilli voucher NIBGE MOS-00828 cytochrome oxidase subunit 1 (COI) gene, partial cds: mitochondrial	Phagomyia cogilli	1205	1205	97%	0.0	99.70%	658	KF406606.1
<input checked="" type="checkbox"/> Aedes vittatus voucher WRBU-1943-99 cytochrome oxidase subunit 1 (COI) gene, partial cds: mitochondrial	Aedes vittatus	1205	1205	97%	0.0	99.70%	658	MT519729.1
<input checked="" type="checkbox"/> Aedes cogilli voucher NIBGE MOS-01591 cytochrome oxidase subunit 1 (COI) gene, partial cds: mitochondrial	Phagomyia cogilli	1205	1205	97%	0.0	99.70%	658	KF406613.1
<input checked="" type="checkbox"/> Aedes vittatus voucher WRBU-1943-75 cytochrome oxidase subunit 1 (COI) gene, partial cds: mitochondrial	Aedes vittatus	1205	1205	97%	0.0	99.70%	658	MT519730.1
<input checked="" type="checkbox"/> Aedes cogilli voucher NIBGE MOS-00829 cytochrome oxidase subunit 1 (COI) gene, partial cds: mitochondrial	Phagomyia cogilli	1199	1199	97%	0.0	99.54%	658	KF406580.1
<input checked="" type="checkbox"/> Aedes cogilli voucher NIBGE MOS-01583 cytochrome oxidase subunit 1 (COI) gene, partial cds: mitochondrial	Phagomyia cogilli	1199	1199	97%	0.0	99.54%	658	KF406619.1
<input checked="" type="checkbox"/> Aedes vittatus voucher NP2_14M cytochrome c oxidase subunit I (COX1) gene, partial cds: mitochondrial	Aedes vittatus	1197	1197	96%	0.0	99.54%	657	OL331077.1
<input checked="" type="checkbox"/> Aedes cogilli voucher NIBGE MOS-01586 cytochrome oxidase subunit 1 (COI) gene, partial cds: mitochondrial	Phagomyia cogilli	1195	1195	97%	0.0	99.39%	658	KF406584.1
<input checked="" type="checkbox"/> Aedes cogilli voucher NIBGE DIP-00375 cytochrome oxidase subunit 1 (COI) gene, partial cds: mitochondrial	Phagomyia cogilli	1195	1195	97%	0.0	99.39%	658	KF406618.1
<input checked="" type="checkbox"/> Aedes cogilli voucher NIBGE MOS-01755 cytochrome oxidase subunit 1 (COI) gene, partial cds: mitochondrial	Phagomyia cogilli	1194	1194	97%	0.0	99.39%	658	KF406595.1
<input checked="" type="checkbox"/> Aedes cogilli voucher NIBGE DIP-00374 cytochrome oxidase subunit 1 (COI) gene, partial cds: mitochondrial	Phagomyia cogilli	1194	1194	97%	0.0	99.39%	658	KF406620.1
<input checked="" type="checkbox"/> Aedes cogilli voucher NIBGE MOS-01778 cytochrome oxidase subunit 1 (COI) gene, partial cds: mitochondrial	Phagomyia cogilli	1194	1194	97%	0.0	99.39%	658	KF406581.1
<input checked="" type="checkbox"/> Aedes cogilli voucher NIBGE MOS-01588 cytochrome oxidase subunit 1 (COI) gene, partial cds: mitochondrial	Phagomyia cogilli	1194	1194	97%	0.0	99.39%	658	KF406621.1
<input checked="" type="checkbox"/> Aedes cogilli voucher NIBGE MOS-01779 cytochrome oxidase subunit 1 (COI) gene, partial cds: mitochondrial	Phagomyia cogilli	1194	1194	97%	0.0	99.39%	658	KF406585.1
<input checked="" type="checkbox"/> Aedes vittatus voucher NP2_16M cytochrome c oxidase subunit I (COX1) gene, partial cds: mitochondrial	Aedes vittatus	1192	1192	96%	0.0	99.39%	657	OL331079.1

Figure 4: Sequences from the whole world producing significant alignments

Descriptions		Graphic Summary	Alignments							
Sequences producing significant alignments				Download	Select columns	Show	100			
<input checked="" type="checkbox"/> select all 14 sequences selected				Graphics		Distance tree of results		MSA Viewer		
Description	Scientific Name	Max Score	Total Score	Query Cover	E value	Per Ident	Acc. Len	Accession		
<input checked="" type="checkbox"/> MK491498.1/Kerala03		1245	1245	99%	0.0	99.85%	678	Query_5737388		
<input checked="" type="checkbox"/> OL851671.1/Tamilnadu02		1175	1175	95%	0.0	99.38%	650	Query_5737384		
<input checked="" type="checkbox"/> QP317577.1/Tamilnadu		1175	1175	95%	0.0	99.38%	650	Query_5737383		
<input checked="" type="checkbox"/> MZ828135.1/Tamilnadu03		1090	1090	88%	0.0	99.50%	599	Query_5737385		
<input checked="" type="checkbox"/> MT858330.1/Kerala02		968	968	77%	0.0	99.81%	527	Query_5737387		
<input checked="" type="checkbox"/> QR879749.1/Odisha		929	929	74%	0.0	99.80%	506	Query_5737378		
<input checked="" type="checkbox"/> PQ483327.1/Kolkata02		880	880	71%	0.0	99.38%	732	Query_5737379		
<input checked="" type="checkbox"/> MW931755.1/Kerala01		863	863	70%	0.0	99.37%	724	Query_5737386		
<input checked="" type="checkbox"/> PQ483324.1/Kolkata04		802	802	65%	0.0	99.32%	694	Query_5737382		
<input checked="" type="checkbox"/> PQ483326.1/Kolkata		785	785	63%	0.0	99.77%	678	Query_5737380		
<input checked="" type="checkbox"/> PQ483325.1/Kolkata03		675	675	55%	0.0	99.20%	626	Query_5737381		
<input checked="" type="checkbox"/> MK243685.1/Tamilnadu04		649	649	52%	0.0	99.44%	357	Query_5737389		
<input checked="" type="checkbox"/> KR872404.1/Coimbatore		597	597	71%	7e-174	89.03%	502	Query_5737391		
<input checked="" type="checkbox"/> AY834246.1/Pondicherry		597	597	71%	7e-174	89.03%	512	Query_5737390		

Figure 5: Sequences from India producing significant alignments

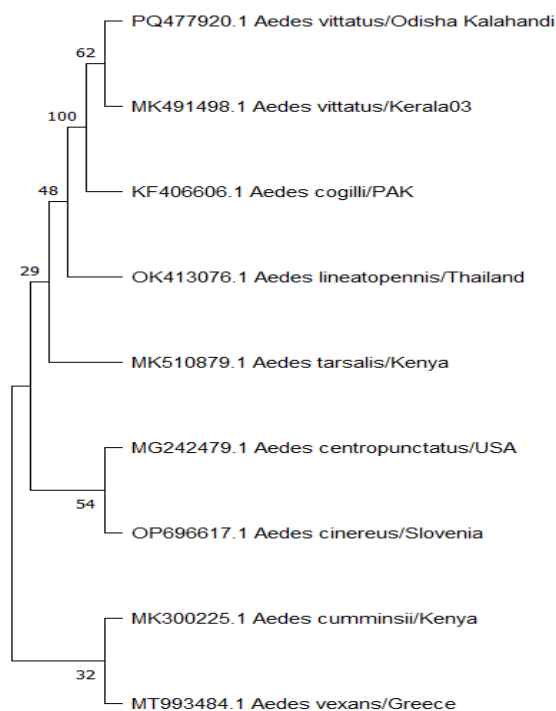

Figure 6: Molecular phylogenetic analysis of *Ae. vittatus* by Maximum Likelihood method of the World.

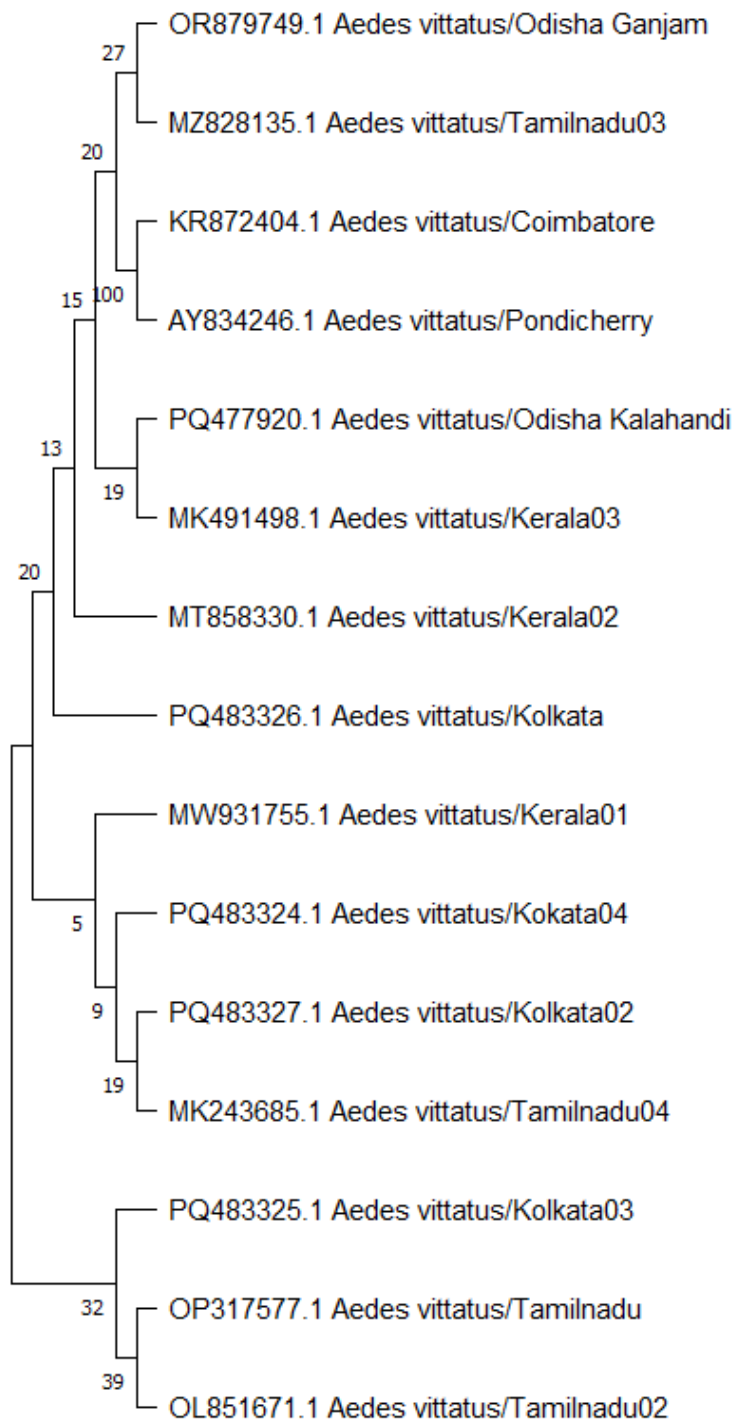

Figure 7: Molecular phylogenetic analysis of *Ae. vittatus* by Maximum Likelihood method of India.

Mosquito Species	1	2	3	4	5	6	7	8	9	10	11	12	13	14	15
PQ477920.1 <i>Aedes_v</i> <i>ittatus</i> /Odisha_Kalahandi															
PQ483327.1 <i>Aedes_v</i> <i>ittatus</i> /Kolkata02	0.00 821 36														
PQ483326.1 <i>Aedes_v</i> <i>ittatus</i> /Kolkata	0.00 233 64	0.00 592 59													
PQ483325.1 <i>Aedes_v</i> <i>ittatus</i> /Kolkata03	0.00 800 00	0.00 160 77	0.00 480 00												
PQ483324.1 <i>Aedes_v</i> <i>ittatus</i> /Kolkata04	0.00 674 16	0.00 289 02	0.00 589 97	0.00 319 49											
OR879749.1 <i>Aedes_v</i> <i>ittatus</i> /Odisha_Ganjam	0.00 197 63	0.00 970 87	0.00 283 29	0.01 000 00	0.00 810 81										
OP317577.1 <i>Aedes_v</i> <i>ittatus</i> /Tamilnadu	0.00 618 24	0.00 438 60	0.00 755 67	0.00 000 00	0.00 241 55	0.00 790 51									
OL851671.1 <i>Aedes_v</i> <i>ittatus</i> /Tamilnadu02	0.00 617 28	0.00 437 64	0.00 753 77	0.00 000 00	0.00 240 96	0.00 790 51	0.00 000 00								
MZ828135.1 <i>Aedes_v</i> <i>ittatus</i> /Tamilnadu03	0.00 500 83	0.01 108 65	0.00 510 20	0.01 179 94	0.00 978 00	0.00 395 26	0.01 001 67	0.01 001 67							
MW931755.1 <i>Aedes_v</i> <i>vittatus</i> /Kerala01	0.00 630 25	0.00 138 31	0.00 443 79	0.00 000 00	0.00 144 30	0.00 748 13	0.00 224 72	0.00 224 22	0.00 909 09						
MT858330.1 <i>Aedes_v</i> <i>ittatus</i> /Kerala02	0.00 189 75	0.00 452 49	0.00 261 10	0.00 303 03	0.00 250 00	0.00 402 41	0.00 379 51	0.00 379 51	0.00 569 26	0.00 232 02					
MK491498.1 <i>Aedes_v</i> <i>vittatus</i> /Kerala03	0.00 147 49	0.01 024 59	0.00 466 20	0.01 063 83	0.00 896 86	0.00 197 63	0.00 463 68	0.00 462 96	0.00 500 83	0.00 838 57	0.00 189 75				
MK243685.1 <i>Aedes_v</i> <i>vittatus</i> /Tamilnadu04	0.00 560 22	0.00 560 22	0.00 560 22	0.00 615 38	0.00 560 22	0.00 903 61	0.00 840 34	0.00 840 34	0.01 120 45	0.00 560 22	0.00 840 34	0.00 560 22			
KR872404.1 <i>Aedes_v</i> <i>ittatus</i> /Coimbatore	0.11 570 25	0.11 706 35	0.12 723 21	0.12 658 23	0.12 258 06	0.11 980 44	0.11 258 28	0.11 233 48	0.11 607 14	0.11 491 94	0.11 389 52	0.11 752 58	0.13 165 27		
AY834246.1 <i>Aedes_v</i> <i>ittatus</i> /Pondichery	0.11 570 25	0.11 673 15	0.12 663 76	0.12 592 59	0.12 210 53	0.11 980 44	0.11 258 28	0.11 233 48	0.11 607 14	0.11 462 45	0.11 389 52	0.11 752 58	0.13 165 27	0.00 000 00	

Table 1: Distance matrix of Indian COI gene sequences of *Aedes vittatus*

4. DISCUSSION

As of 1st November 2024, the NCBI GenBank contained 102 COI gene sequences of *Ae. vittatus*, including the KSP02 isolated strain, out of these seven from Odisha and twenty-two from India. MK491498 and our isolated strain PQ477920 belonged to the same clade. However, when compared to *Ae. lineatopennis* (Thailand), *Ae. tarsalis* (Kenya), *Ae. centropunctatus* (USA), *Ae. cinereus* (Slovenia), *Ae. cumminsii* (Kenya), and *Ae. vexans* (Greece), both the Kerala03 and Kalahandi Odisha strains were similar to the Pakistan strain, *Ae. cogilli* locations are marked in Figure 4, 6 & 8.

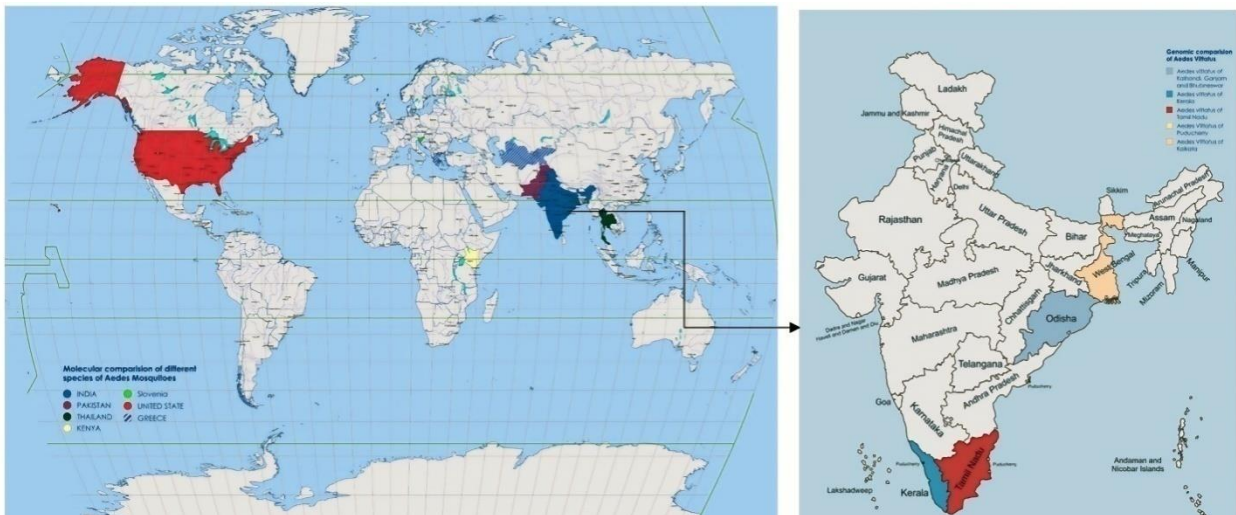

Figure 8: *Aedes* species of different countries having maximum similarity with Kalahandi, Odisha isolated *Aedes vittatus* strain (this world map has no scale was made online, and the website link was <https://www.mapchart.net/india.html>)

There has no continuous evidence of transmission by *Ae. vittatus*, largely due to the lack of molecular characterisation of this species. However, based on the available data, it is likely that *Ae. vittatus* has evolved in distinct ecotypes, leading to different evolutionary pathways. This variation could increase the species' vectorial capacity in various regions worldwide. According to certain reports, *Ae. vittatus* transmitted the Zika virus in Africa, America, and Asia [21–23] and the Dengue virus in Africa, Asia, and Europe [24, 25]. Additionally, there was evidence that *Ae. vittatus* was responsible for the Yellow fever virus in Africa and South America [26, 27] and Chikungunya in Africa, America, Asia, and Europe [26]. In Africa, Asia, and Europe, these mosquitoes were also the cause of Encephalitis [28]. In the Indian subcontinent, these mosquitoes can carry Dengue, Chikungunya, Yellow fever, or Encephalitis at any time. Globalisation, urbanisation, and climate change significantly modify the dynamics of disease transmission and enhance the involvement of neglected species, such as *Ae. vittatus*, in disease propagation [29]. It is predicted that, regardless of its native range, climate change will encourage incursions into colder subtropical regions in countries throughout Asia, Europe, and North America. *Ae. vittatus* is found in rural, urban, and peri-urban locations throughout tropical and subtropical regions. It is found at heights from sea level up to 2,500 meters above sea level, thriving in temperatures ranging from 15 to 30 °C [30]. The species is able to adapt to a wide range of habitats, including forests, grasslands, lakes, and deserts. Furthermore, this mosquito species may expand to new regions of the Americas, Europe, and Oceania [30]. Despite arbovirus outbreaks in other parts of the world, *Ae. vittatus* has not yet been connected to any cases in India.

However, in the future, this species could emerge as an important vector in India due to the presence of diverse strains across different geographical areas. This makes it critical to monitor the genetic variation and transmission potential of *Ae. vittatus*. Morphological identification of *Aedes* species can often be confusing, so genetic identification using the COI gene should be adopted across India for effective surveillance of this vector.

Other *Ae. vittatus* strains identified from Ganjam, Odisha were far from our isolated strain **KSP02**, which was highly similar to the *Ae. vittatus* of Kerala03 strain found in a single clade in India (Fig. 7). Our strain was also more similar to the Kerala03 strain than Kerala02 and Kerala01 strains because they belonged to separate clades. Furthermore, because it belongs to various clades, our isolated strain of *Ae. vittatus* **KSP02** was close to the Kolkata strain (PQ483326.1) of *Ae. vittatus* but also far from the Kolkata4 and Kolkata2 strains. It is surprising that the *Ae. vittatus* strain from Kolkata03 is farther distant than the other strains from Kolkata 01, 02, and 04 strains in terms of distance (Table 1).

5. CONCLUSION

Ae. vittatus vector might be introduced to Kalahandi, Odisha from neighboring states. The presence of this competent vector is most probably a risk of transmission of arboviruses such as Dengue fever, Yellow fever, West Nile virus, Zika virus, and Chikungunya virus in this area. Because of its high vector potential, *Ae. vittatus* is probably of special medical importance in addition to *Ae. aegypti* and *Ae. albopictus*. More entomological research is required to create efficient vector management strategies that can stop the spread of *Ae. vittatus* and associated arboviral diseases in Odisha. Thorough study would improve our knowledge and supply crucial information to back up focused intervention tactics.

Disclaimer (Artificial intelligence)

Option 1:

Author(s) hereby declare that NO generative AI technologies such as Large Language Models (ChatGPT, COPILOT, etc.) and text-to-image generators have been used during the writing or editing of this manuscript.

Option 2:

Author(s) hereby declare that generative AI technologies such as Large Language Models, etc. have been used during the writing or editing of manuscripts. This explanation will include the name, version, model, and source of the generative AI technology and as well as all input prompts provided to the generative AI technology

Details of the AI usage are given below:

- 1.
- 2.
- 3.

8. REFERENCES

1. Weaver SC, Charlier C, Vasilakis N, Lecuit M, Chikungunya Z, et al., Emerging Vector-Borne Viral Diseases. Annual Review of Medicine. 2018;69:395-408.
2. Sudeep AB, Shil. P. *Aedes vittatus* (Bigot) mosquito: an emerging threat to public health. Journal of Vector Borne Diseases. 2017;54:29-300.

3. Brown JE, Obas V, Morley V, Powell JR. Phylogeography and spatio-temporal genetic variation of *Aedes aegypti* (diptera: culicidae) populations in the Florida keys. *J Med Entomol* 2013; 50(2): 294–9.
4. Outammassine, A., Zouhair, S. and Loqman, S. Global potential distribution of three underappreciated arboviruses vectors (*Aedes japonicus*, *Aedes vexans* and *Aedes vittatus*) under current and future climate conditions. *Transboundary and emerging diseases* 2022; 69(4), e1160-e1171.
5. Kumari, R., Kumar, K. and Chauhan, L.S. First dengue virus detection in *Aedes albopictus* from Delhi, India: Its breeding ecology and role in dengue transmission. *Tropical Medicine & International Health* 2011; 16(8), 949-954.
6. Alarcón-Elbal, P.M., Rodríguez-Sosa, M.A., Newman, B.C. and Sutton, W.B. The first record of *Aedes vittatus* (Diptera: Culicidae) in the Dominican Republic: Public health implications of a potential invasive mosquito species in the Americas. *Journal of Medical Entomology* 2020; 57(6), 2016-2021.
7. Sudeep, A.B., Mohandas, S., Bhanarkar, S.R., Ghodke, Y.S. and Sonawane, P.A. Vector competence of *Aedes vittatus* (Bigot) mosquitoes from India for Japanese encephalitis, West Nile, Chandipura and Chittoor viruses. *Journal of Vector Borne Diseases* 2020; 57(3), 234-239.
8. Diallo, D., Diagne, C.T., Hanley, K.A., Sall, A.A., Buenemann, M., Ba, Y., Dia, I., Weaver, S.C. and Diallo, M. Larval ecology of mosquitoes in sylvatic arbovirus foci in southeastern Senegal. *Parasites & vectors* 2012; 5, 1-17.
9. Ramadan, H.A. and Baeshen, N.A. Biological Identifications through DNA barcodes. *Biodiversity Conservation and Utilization in a Diverse World* 2012; 109-128.
10. Ondrejicka, D.A., Locke, S.A., Morey, K., Borisenko, A.V. and Hanner, R.H. Status and prospects of DNA barcoding in medically important parasites and vectors. *Trends in Parasitology* 2014; 30(12), 582-591.
11. Godfray H.C.J., “Challenges for taxonomy. The discipline will have to reinvent itself if it is to survive and flourish. *Nature* 2002; 417(6884), 409–417.
12. Dawnay, N., Ogden, R., McEwing, R., Carvalho, G.R. and Thorpe, R.S. Validation of the barcoding gene COI for use in forensic genetic species identification. *Forensic science international* 2007; 173(1), 1-6.
13. Schaffner F, Kaufmann C, Hegglin D, and Mathis A., “The invasive mosquito *Aedes japonicus* in Central Europe. *Med Vet Entomol.* 2009; vol. 23, 448–451.
14. Paupy, C., Delatte, H., Bagny, L., Corbel, V. and Fontenille, D. *Aedes albopictus*, an arbovirus vector: from the darkness to the light. *Microbes and infection* 2009; 11(14-15), 1177-1185.
15. Siregar, F.A. and Makmur, T. March. Survey on aedes mosquito density and pattern distribution of *aedes aegypti* and *aedes albopictus* in high and low incidence districts in north sumatera province. In *IOP Conference Series: Earth and Environmental Science* 2018; (Vol. 130, No. 1, p. 012018). IOP Publishing.
16. Rueda, L.M. Pictorial keys for the identification of mosquitoes (Diptera: Culicidae) associated with dengue virus transmission. *Zootaxa* 2004; 589(1), 1-60.
17. Elamin, Y.E., Bashir, N.H., Elhaj, H.F., Allah, E.A.A.H., Khogali, A., Alzahrani, M.H. and Hassan, M.A.M. Mosquito fauna and the first record of *Aedes vittatus* (Diptera: Culicidae) in Kassala State, eastern Sudan 2023; 10(5), 28–34, doi: 10.22271/23487941.2023.v10.i5a.693.

18. Trees, R.P. The neighbor-joining method: a new method for. *Mol Biol Evol* 1987; 4(4), 406-425.
19. Tamura, K., Nei, M. and Kumar, S. Prospects for inferring very large phylogenies by using the neighbor-joining method. *Proceedings of the National Academy of Sciences* 2004; 101(30), 11030-11035.
20. Kumar, S., Stecher, G., Li, M., Knyaz, C. and Tamura, K. MEGA X: molecular evolutionary genetics analysis across computing platforms. *Molecular biology and evolution* 2018; 35(6), 1547-1549.
21. Wahid B, Ali A, Rafique S, Idrees M. Zika: As an emergent epidemic. *Asian Pac J Trop Med*. 2016;9:723–9.
22. Vorou R. Zika virus, vectors, reservoirs, amplifying hosts, and their potential to spread worldwide: what we know and what we should investigate urgently. *Int J Infect Dis*. 2016;48:85–90.
23. Diallo D, Sall AA, Diagne CT, Faye O, Faye O, Ba Y, et al. Zika virus emergence in mosquitoes in southeastern Senegal, 2011. *PLoS One*. 2014;9:e109442.
24. Angel B, Joshi V. Distribution and seasonality of vertically transmitted dengue viruses in *Aedes* mosquitoes in arid and semi-arid areas of Rajasthan, India. *J Vector Borne Dis*. 2008;45:56–9.
25. Diallo M, Sall AA, Moncayo AC, Ba Y, Fernandez Z, Ortiz D, et al. Potential role of sylvatic and domestic African mosquito species in dengue emergence. *Am J Trop Med Hyg*. 2005;73:445–9.
26. Vazeille M, Jeannin C, Martin E, Schaffner F. A risk for Mediterranean countries? *Acta Trop*. 2008;105:200–2.
27. Barrett ADT, Higgs S. Yellow Fever: A disease that has yet to be conquered. *Annu Rev Entomol*. 2007;52:209–29.
28. Ngoagouni C, Kamgang B, Manirakiza A, Nangouma A, Paupy C, Nakoune E, Kazanji M. Entomological profile of yellow fever epidemics in the Central African Republic, 2006–2010. *Parasit Vectors*. 2012; 5:175.
29. Petersen, V., Santana, M., Karina-Costa, M., Nachbar, J.J., Martin-Martin, I., Adelman, Z.N. and Burini, B.C. *Aedes* (*Ochlerotatus*) *scapularis*, *Aedes japonicus japonicus*, and *Aedes* (*Fredwardsius*) *vittatus* (Diptera: Culicidae): Three Neglected Mosquitoes with Potential Global Health Risks. *Insects* 2024; 15(8), 600.
30. Mejía-Jurado, E., Echeverry-Cárdenas, E. and Aguirre-Obando, O.A., 2024. A new vector emerges? *Aedes vittatus* (Diptera: Culicidae): ecological description and current and future potential global geographic invasion. *Revista de Biología Tropical* 2024; 72(1), 1-25