

Study of radio reconnaissance receivers designed on the basis of solid-state filters

ABSTRACT

Radio intelligence systems are vital technological resources that contribute significantly to contemporary security, defense, and intelligence efforts. They enable the monitoring of adversaries' communication signals, the decryption of encrypted information, and the acquisition of strategic advantages. These systems are essential for military operations, counter-terrorism efforts, national security, and strategic planning. As radio intelligence continues to evolve, it is anticipated that more effective and multifunctional systems will emerge in the future. In modern electronic warfare, radio reconnaissance stations are essential for effective signal detection, classification, and geolocation of enemy communication and radar signals. Current advancements in radio reconnaissance technology focus on enhancing measurement accuracy and reliability, crucial for precise threat identification and situational awareness. Key improvements include implementing high-resolution digital signal processing algorithms, advanced filtering techniques, and real-time data fusion to increase detection precision across complex environments. Furthermore, there is a strategic emphasis on reducing the physical dimensions and weight of these stations to improve mobility and operational efficiency in diverse field conditions. Innovations in miniaturized components, lightweight materials, and compact antenna arrays are central to these design objectives, facilitating deployment in both manned and unmanned platforms. This approach not only optimizes the performance of reconnaissance stations but also broadens their applicability across various operational scenarios, making them integral to modern defense systems. In the article, the application of solid-state filters in the spectrum analyzers of radio reconnaissance receivers was considered in order to increase the measurement accuracy and reliability of radio reconnaissance stations, and to reduce their size and weight.

In the article, the modeling of load-connected filter structures was conducted to calculate quasi-statistical potential diagrams, which allows for the optimization of their parameters and reduces the design time of devices based on these filters.

The research work was carried out in military unit No. N

Keywords: filter, electrode, load coupled device, frequency, signal.

1. INTRODUCTION

Radio-intelligence systems (SIGINT - Signals Intelligence) are technological tools that ensure the acquisition of intelligence information related to the monitoring, reception, analysis and use of signals broadcast over radio and electromagnetic waves. These systems are considered one of the most important tools of the military, security and intelligence services and are used in a wide range of areas, especially in the complex combat conditions of the modern era and play a critical role in the context of electronic warfare.

The following can be mentioned as the main components of radio intelligence systems:

1. Detection and reception of signals: The main function of radio reconnaissance is to monitor and receive various types of signals broadcast on radio frequencies. These signals can be both

encrypted and open data and come from various means of communication (telephone, radio, radar, satellite) [6,11,12].

2. Signal analysis: Received signals are analyzed through special equipment and software. The purpose of this analysis is to determine the type, source, frequency, position and destination of the signal. In encrypted signals, the main goal is to decode messages and analyze their content.

3. Geographical identification of signal sources: Through radio reconnaissance, it is possible to determine the exact location and source of communication systems used by adversaries or objects of interest. Thanks to this geographical determination, strategic information about the enemy's positions, directions of movement and operational plans is obtained [5,10,13].

4. Frequency spectrum management and monitoring: Radio intelligence systems are used to monitor signals broadcast on certain frequencies and to identify devices operating in that spectrum. This is especially important in the military, because control over the frequency spectrum is critical in modern warfare.

5. Electronic warfare: Electronic warfare tactics are used as part of radio reconnaissance. It is implemented to interfere with the adversary's communication channels, making it difficult for them to obtain correct information and exchange information. Jamming or disrupting the propagation of signals is one of the main components of this process.

The following can be mentioned as areas of application of radio intelligence systems:

1. Military intelligence: Radio intelligence systems are of great importance in the course of military operations. They help determine operational plans, courses of action, objectives, and tactical advantages by monitoring enemy communications channels. Analyzing the opponent's radar signals and satellite communication data also provides an opportunity to obtain important information in combat conditions.

2. Counter-terrorism and internal security: Radio intelligence systems play an important role for states in preventing terrorist attacks and ensuring national security. Through these systems, the communication activities of terrorists and illegal groups are monitored, their operational plans are determined and preventive measures are taken.

3. Surveillance of sea and airspace: Navies and air forces can monitor the enemy's air and sea movements through radio reconnaissance systems, analyze their communications and radar signals, and take preventive measures based on this information.

4. Strategic reconnaissance: Radio reconnaissance is also used for long-term strategic planning. States and military blocs widely use radio intelligence tools to monitor the military and technological developments of other countries and to anticipate their potential threats.

Radio reconnaissance technologies consist of very complex and advanced equipment. These technologies use high-precision instruments to track and analyze various radio frequencies. Modern radio intelligence systems take advantage of advanced technologies such as artificial intelligence, machine learning and big data to automatically analyze signals and quickly decipher data. Satellite-based reconnaissance systems, long-range radars, mobile communication tracking devices are important components of this field.

The significance of radio intelligence has grown in contemporary society. With the advancement of global communication networks, satellites, and the Internet, numerous nations and organizations are concentrating their intelligence efforts in this area. The relevance of electronic warfare is on the rise, as modern battlefields extend beyond traditional physical environments. Nowadays, cyberattacks, communication disruptions, and network control are crucial elements of military operations.

Competition between different states and organizations in the field of industrial and economic intelligence with radio reconnaissance systems is intensifying. These systems are also used to steal technological secrets, enter corporate networks and obtain strategic information.

In order to effectively fight against rival radio electronic devices, there should be enough information about the main parameters and characteristics of those devices. This information is obtained through all possible forms of intelligence: radio intelligence, agent intelligence, photography, surveillance, etc.

The main purpose of using radio reconnaissance systems is to detect and capture (record) the signals radiated by the opponent, to determine the coordinates of the radiation sources and to decipher (decode) the captured signals. The radio intelligence station used to perform these should include antennas with special characteristics, an intelligence receiver, a detecting and capturing indicator, a recording (recording) device and a signal analyzer. As a rule, reconnaissance stations are placed on board airplanes or other moving objects. For this reason, its dimensions and weight should be as small as possible. As a special type of radio reconnaissance stations, consisting of an antenna, a receiver and an indicator, in aircraft, submarines, etc. are stations that are deployed and inform the crews of these objects that they are irradiated by a rival radar station (RLS).

2. RESEARCH OBJECTS AND METHODS

2.1. INVESTIGATION OF MULTI-CHANNEL DIRECT GAIN RADIO RECONNAISSANCE RECEIVER

The effectiveness of radio reconnaissance stations is characterized by the probability of detecting a working radiation source and the accuracy of determining its coordinates.

Detection of captured signals against the background of obstacles and determination of their frequency is carried out by means of a reconnaissance receiver. The difference of the intelligence receiver from the usual receivers is that it has an extremely wide frequency range [1]. Both directly amplified and superheteradine type receivers are used in radio reconnaissance. Multichannel direct amplification receivers used in radio reconnaissance (Figure 1.a) are simple and do not require retuning, and the received signal at their output is practically simultaneous with the input signal. Disadvantages of direct amplification reconnaissance receivers include low sensitivity and wide bandwidth. As a result of the wide bandwidth of each channel, the frequency of the captured signal is not measured, and only the frequency range in which it is noted, which is determined by the frequency band of one channel (Figure 1. b). Direct-amplified multichannel intelligence receivers are designed for use on boats, aircraft, etc. used to notify crews of objects that they have been irradiated by adversary RLS.

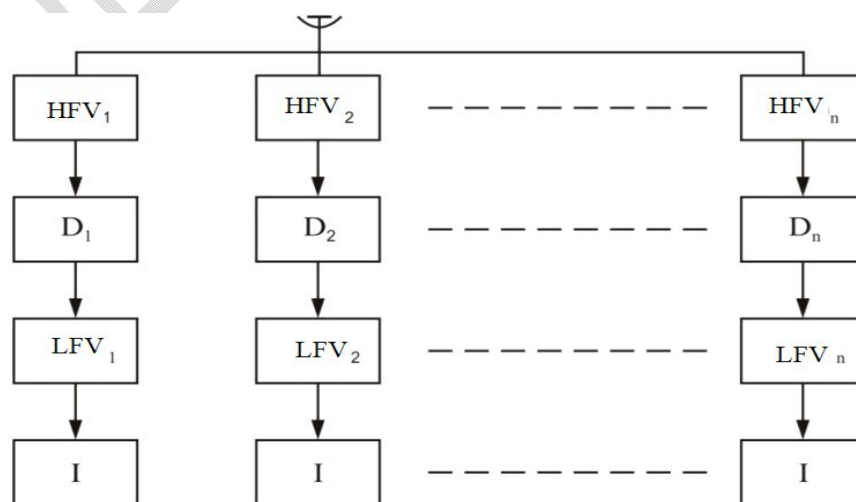

a)

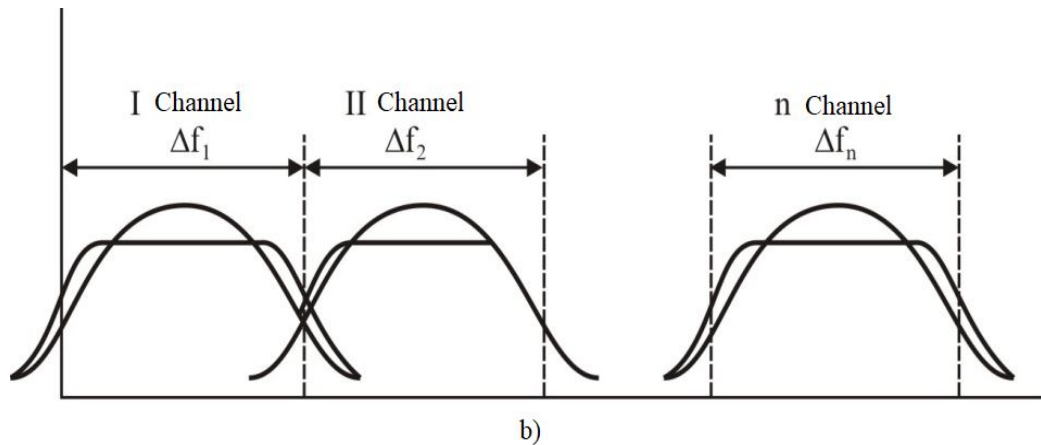

Figure 1. Multi-channel direct-amplified radio reconnaissance receiver:
a) structural scheme; b) spectrum analyzer

The sensitivity and frequency resolution of superheterodyne two-frequency conversion receivers (as shown in Fig. 2) are superior to those of direct-amplification circuits. This enhanced performance is attributed to the passband of the intermediate frequency amplifier, which can be retuned across a wide frequency range. The disadvantage of these receivers is that the installation and operating conditions are complicated and the frequency search time is long.

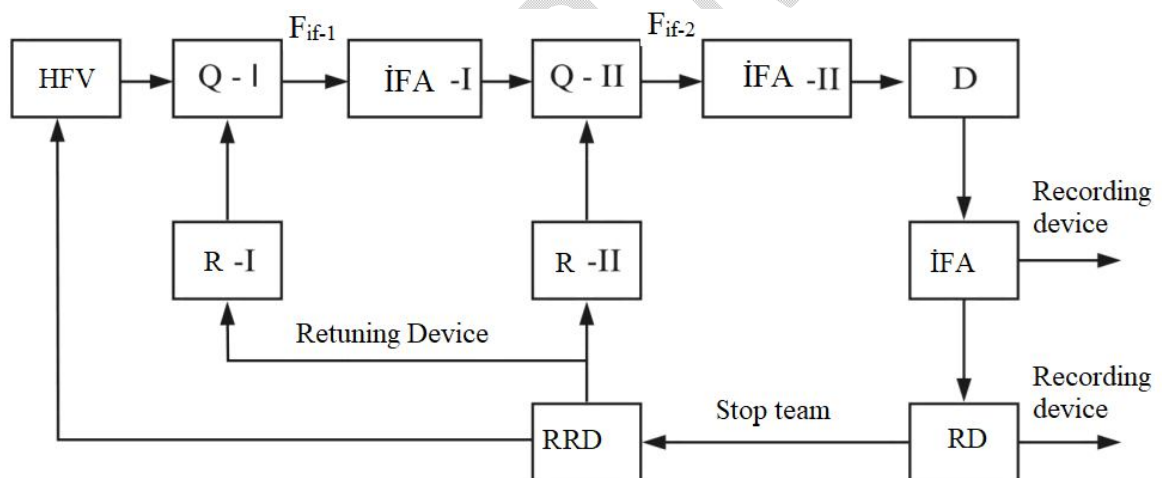

Figure 2. Superheterodyne radio reconnaissance receiver

Below is an explanation of each block in the diagram shown in Figure 2:

HFV- (high-frequency voltage): This block is located at the input of the system and is a module that receives high-frequency signals. This signal is directed to other parts of the system.

R-I (receiver block-I): This block receives the signals from the YTG and cleans and amplifies them for initial processing.

IFA-I (intermediate frequency amplifier): In this block, the signal is amplified and transferred to a certain intermediate frequency. This provides more accurate signal analysis and processing.

R-II (receiver block-II): This is the second admission block. Here the signal is reanalyzed more accurately and the signal is made ready for operation.

IFA-II (intermediate frequency amplifier II): This block performs signal re-amplification and conversion to the second intermediate frequency. The signal is then forwarded to other modules for processing.

D (demodulation): This block demodulates the signal, that is, the useful information of the signal is extracted and prepared for analysis.

IFA (intermediate frequency amplifier): It is a block designed for automatic amplification of the signal and its recording. Here the signal is amplified and directed to the recording device.

RD (recorder): The signal processed and demodulated by the system is recorded and stored here. It is used for data storage.

RRD (reboot unit): This unit performs the function of system re-rooting and changing settings. This is necessary for more accurate reception and processing of the signal.

Analyzers used in radio reconnaissance stations determine the carrier frequency, duration, shape and repetition of pulses, frequency, observation form and speed, the width and shape of the antenna radiation pattern, the polarization of the radiation and its intensity. Sometimes the set parameters are limited by carrier frequency, pulse duration and repetition rate. To analyze the spectrum of signals, serial spectrum analyzers are used, because the dimensions of parallel spectrum analyzers are very large and they are more complex.

As mentioned, radio reconnaissance stations are mainly placed on moving objects. For this reason, they are required to be small in size, light in weight, and high in measurement accuracy and reliability. Both types of radio reconnaissance receivers use a spectrum analyzer. This means using a large number of filters. To meet the above-mentioned requirements, it is necessary to use filters made with more modern technology. For this purpose, it is more appropriate to use filters based on load-related devices. So, these filters are distinguished by their low cost, small size, lightness, high reliability and accuracy.

2.2. A STUDY OF SPLIT-ELECTRODE CHARGE-BASED FILTERING IN RADIO RECONNAISSANCE RECEIVERS

Due to many of its features, better characteristics are obtained in segmented electrode structures (Figure 3). The main element of the filter is a delay line based on a load-coupled structure where one of the electrodes in each cascade is split into two parts [2,7,11,13].

In electronics, particularly in signal processing and filtering technologies, segmented electrode structures offer improved performance over traditional designs. These structures are often employed in high-frequency filters where precise control over signal propagation is crucial. By dividing one of the electrodes in each cascade into two segments, the system can achieve finer tuning of the delay line, which is essential for better signal control and reduced interference.

A delay line is a critical component in such filters as it controls the time it takes for a signal to pass from one point to another. In this case, the load-coupled structure helps in managing the signal's propagation by influencing the interaction between the electrical load and the signal. This results in better phase stability, reduced signal loss, and improved frequency selectivity, which are key advantages in communication systems, radar, and radio detection technologies.

By splitting the electrodes in each cascade, the system can enhance its ability to filter out unwanted frequencies while allowing desired signals to pass through more cleanly. This segmentation helps to minimize distortion and phase errors, which are common issues in high-frequency applications. Additionally, it allows for a more compact design, which is often necessary in modern electronic systems that demand high performance in limited physical space.

In Figure 3.a, the signal is counted by electrodes (F_3) untimed in the form of load. When the load is transferred from the (F_2) electrode to the k -th counting electrode (F_3), the current flowing to the k -th counting bus consists of two components: one of them equals the current that can flow in the absence of the signal load, and the second approximately corresponds to the signal load. As a result, the signal load can be determined by integrating the current flowing to the F_3 electrode during the

transfer of loads. Measurement is performed by splitting the (F_3) electrode and integrating the currents flowing from each part separately. When the electrode is split into two equal parts, zero weighting coefficients are obtained [3,9]. Positive and negative coefficients are obtained by dividing the loads between the (F_{3+}) and (F_{3-}) electrodes in the necessary proportions. Summation is carried out by connecting the (F_{3+}) and (F_{3-}) electrodes as shown in Figure 3.b. The output signal of the filter is generated by integrating and subtracting the currents of the (F_{3+}) and (F_{3-}) counting clock buses (in the output amplifier). The method of split electrodes is widely used for load-based filters.

The scheme shown in Figure 3. has found wide application, but in some cases it is possible to improve the working characteristics of the filter by using other schematic solutions. Usually split-electrode filters, which often have small weighting coefficients, have a limited dynamic range, and sampling frequency does not exceed 5MHz. If the level of the in-phase signal at the input of the output amplifier is too large (20-30 dB higher than the useful output signal), the dynamic range is limited. As the number of transmissions with a low weighting factor is large, the synphase signal becomes even higher. This is explained by the fact that a small weighting factor corresponds to the fact that a relatively large signal is given to the input of a differential amplifier from electrodes whose width is approximately half of the width of the channel [4,8].

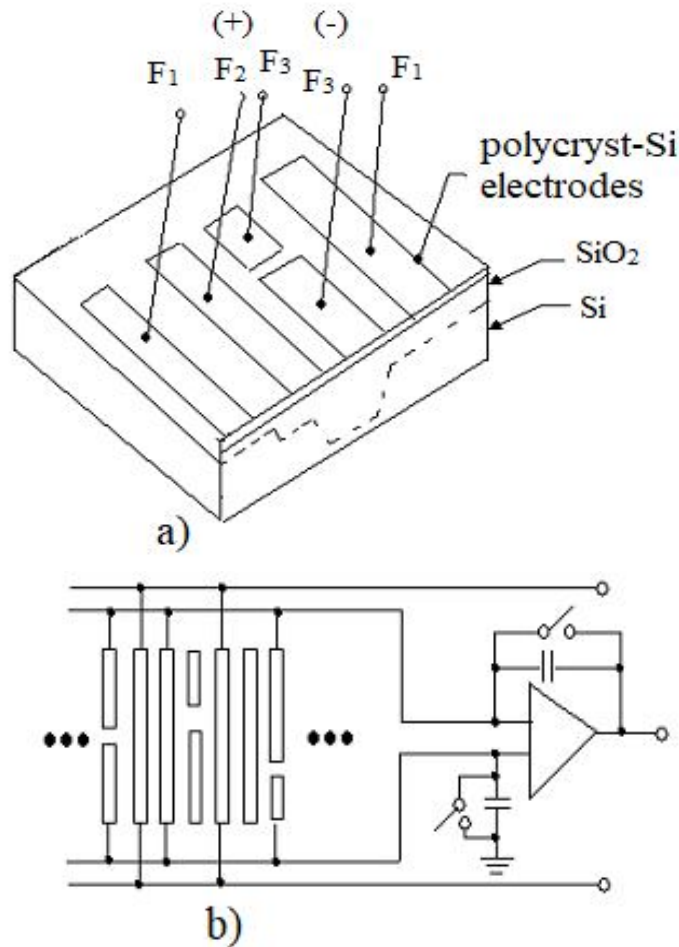

Figure 3. Split-electrode charge-based filter (a) – filter structure (b) description of charge counting method

Usually, the ratio of bandwidth to discretization frequency is high (10%) in filters with small weighting coefficients. On the other hand, in tuned and narrowband filters, the weighting coefficients are usually quite large and in-phase, and the signals are not large.

2.3. CALCULATION OF QUASI-STATISTICAL POTENTIAL DIAGRAMS IN LOAD-COUPLED DEVICES

The functional areas of the cores of charge-coupled devices, which form the basis of the solid-state matrix, are measured in micrometers. These areas create potential barriers, and it is important to consider the two-dimensional and three-dimensional nature of the processes taking place there. This creates a need for two-dimensional modeling in the calculation of their quasi-statistical potential diagrams during the design of the core of load-connected devices. Modeling allows to optimize the parameters of load-related devices and at the same time significantly reduce the volume and duration of experimental modeling. For example, in matrix load-coupled devices with a large number of elements, the choice of additive parameters and structure topology, taking into account two-dimensional effects, ensures the storage and effective transfer of loads. Below is a two-dimensional physical-topological model for calculating the quasi-statistical potential diagrams of the core of load-coupled devices with arbitrary doping profiles and topologies.

Despite the fact that charge-coupled devices are dynamic type devices, the Poisson and Laplace equations of electrostatic potential allow using higher values of the accumulation time compared to the transmission and thermogeneration time of parasitic charges for their modeling, provided that the current passing through the p-n junction is equal to zero. The presented modification of the two-dimensional model takes into account the specific characteristics of load-connected devices and allows analyzing the potential diagrams and load capacities of devices with complex topologies. The distribution of the potential in each cycle of the operation of the load-connected devices can be considered as quasi-statistical and is explained by Poisson's equations with standard boundary conditions. In the given model, the concentration of mobile electrons and holes $[n(x,y)]$ and $[p(x,y)]$ is determined by the following expressions.

$$n(x, y) = n_i \exp \left[\frac{\varphi(x, y) - \varphi_n}{\varphi_T} \right]. \quad (1)$$

$$P(x, y) = n_i \exp \left[\frac{\varphi_p - \varphi(x, y)}{\varphi_T} \right], \quad (2)$$

where φ_n , φ_p are the Fermi quasi-levels for electrons and holes.

specific concentration of n_i -silicon. The main issue is to choose the algorithm for solving the equation, taking into account the specificity of the load-related devices. The analysis of the literature shows that in modern load-related devices, which are characterized by complex profiles of additives, moving load carriers must be taken into account to calculate the load capacities. In this case, it is considered that when operating in the quasi-static mode, there is no current in the charge-connected devices in the core, therefore, the value of the Fermi quasi-levels φ_n and φ_p can be chosen to be local-constant. The change of the Fermi quasi-level from one constant value to another constant value, keeping the condition of zero current equality, occurs in those areas of the structure where the concentration of mobile charge carriers is close to zero. The depleted regions of the p-n transition are among such regions [15].

Thus, the boundary of the regions where the stable values of the Fermi quasi-levels are localized must pass through the depleted regions. In this case, in case of complete impoverishment of the load-connected devices, these areas can be limited to the metallic borders of the p-n junction to calculate the potential distribution [2,15].

The electric potential distribution obtained by solving the Poisson and Laplace equations can be used to calculate the following statistical electrical characteristics of charge-coupled devices: depletion voltage of the channel, charge capacities of the main and non-main charge carriers, potential barriers between potential pools.

The depletion voltage is determined from the following condition.

$$V_y = \varphi_y + V_s \quad (3)$$

Where φ_y -channel depletion potential, V_s -ohmic contact-channel contact potential difference, φ_y -depletion potential is determined by the two-dimensional distribution of the potential in the structure when a channel voltage greater than the depletion voltage is applied to the p-n junction, and V_s is calculated by the potential distribution when the potential well is filled.

$$V_s = \varphi_{\max} - V_a \quad (4)$$

where φ_{\max} is the maximum potential in the channel when there is a load, V_a is the voltage applied to the channel when it is full.

One of the main characteristics of the potential diagrams of charge-coupled devices is the value of the potential barriers between the potential wells, which provide information on the transfer of charges. The automatic design algorithm consists of six main steps, and in each step, either one of the additive doses of the channel area or one of the phase voltages is determined.

In the first stage, the voltage of the "controlled" coil, V_f , and the doping dose, provided that the surface potential barrier is maintained, are determined, and the dependence of the load capacity on the voltage at the phase electrode is calculated. In the second stage, the effective voltage V_g^e given to the cell is determined. In the third stage, the phase voltage and the doping dose of the barrier D_{n2} are set, provided that the potential barrier between the filled "controlled" hole and the "virtual" hole is 0.5V and the weak inversion is maintained on the Si-SiO₂ separating surface. In the fourth stage, the additive dose of the virtual prison is D_p , and in the fifth stage, the additive dose of the virtual fence is determined, n_n , under the condition of keeping the fence between the "managed" and "virtual" holes. In the sixth stage, the additive dose to the "virtual" tank is selected under the condition that the load is transferred to the "managed" tank by passing through the "virtual" fence.

Figure 4, a shows the core topology of the load cell device with the feature of creating a controlled potential barrier n_2 between the region of the controlled hole n , and the regions of the "virtual" hole n_3 and "virtual" fence n , (Figure 4, b).

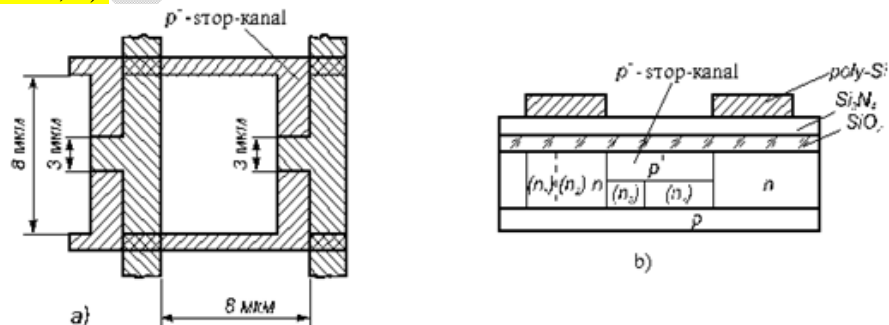

Figure 4. Topology (a) and structure (b) of the core of a virtual phase load-coupled device

In order to analyze the potential diagrams of such a structure during the transfer of charges along the channel, an algorithm was developed taking into account the reduction of the potential of the narrow region of the channel by dividing the control electrode into two parts. The electrode on the

"controlled" potential channel n , has a given voltage V_g , and the electrode on the "controlled" fence n_2 is given an effective voltage V_e , which is less than the real voltage given to reduce the potential of the channel.

As a result, at the initial stage of charge transfer, the main reason for the movement of carriers at high charge density is self-induced drift, but thermal diffusion and tensile fields will determine the final stage of charge transfer within 1ns.

3. CONCLUSION

During the research, the improvement of split-electrode charge-coupled filter in radio reconnaissance receivers gave the following positive results

1. Splitting the electrode into two parts allows for more precise adjustment of the delay line, which is especially important for high-frequency signals.

2. The combination of charge-coupled structures with split electrodes increases both the reliability and measurement accuracy of the filter. This is a significant advantage in communications and radar systems where accuracy is critical during signal transmission.

3. The analysis of quasi-statistical potential diagrams in load-coupled devices reveals that the optimization of charge transfer processes is crucial for enhancing device performance. By employing a two-dimensional modeling approach, it is possible to effectively design and analyze structures with complex topologies, ultimately leading to improved load capacities and potential barrier characteristics.

4. REFERENCES

1. A.T. Rahimov. Fundamentals of building radio and satellite communication systems. Printing house of AzTU, Baku, 2010.

2. Islamov, I.J., Hunbataliyev, E.Z., Abdullayev, R.Sh., Shukurov, N.M., Hashimov Kh. Kh.: Modelling of a Microwave Rectangular Waveguide With a Dielectric Layer and Longitudinal Slots. International Symposium for Production Research, Web of Science, SCOPUS, Science Citation Index Expanded, IEEE, Springer Antalya, 2021, pp. 1-6, DOI: [10.1007/978-3-030-90421-0_47](https://doi.org/10.1007/978-3-030-90421-0_47)

3. E.S. Mammadov. Modeling potential in load coupled devices. Materials of the international scientific and technical conference on the development prospects of modern information and communication technologies, Baku, AzTU, September 22-24, 2011, pp. 64-68.

4. K. Seken, M. Tompsett. Charge Transfer Devices. Mir Publishing House, Moscow, 1978.

5. Islamov I.J., Shukurov N.M., Abdullayev R.Sh., Hashimov Kh.Kh., Khalilov A.I. Diffraction of Electromagnetic Waves of Rectangular Waveguides With A Longitudinal. IEEE Conferences 2020 Wave Electronics and its Application in Information and Telecommunication Systems (WECONF), INSPEC Accession Number: 19806145 (2020), pp. DOI: [10.1109/WECONF48837.2020.9131457](https://doi.org/10.1109/WECONF48837.2020.9131457)

6. I. J. Islamov, E. A. Mammadov, A. R. Rustamov, Kh. Kh. Hashimov, H. Sh. Nabiyev A.I.: Simulation of an Antenna Device with Frequency Scanning International Symposium for Production Research, SCOPUS, Science Citation Index Expanded, IEEE, Springer Antalya 2022, pp. 594-606, DOI: [10.1007/978-3-031-24457-5_46](https://doi.org/10.1007/978-3-031-24457-5_46)

7. A. F. Gochuyeva, Kh. Kh. Hashimov, I. Y. Bayramov, Photoelectret effect in polymer-AIBVI (CdS, ZnS) composites of photosensitive semiconductors / Chalcogenide Letters, vol.20, No.4, pp. 285-291, 2023. <https://doi.org/10.15251/CL.2023.204.285>

8. A.F. Gochuyeva, Kh.Kh. Hashimov, NEW TECHNOLOGIES OF MATRIX COMPOSITE POLYMER PHOTOVOLTAIC AND PHOTOELECTRET MATERIALS. New Materials, Compounds and Applications, Vol.7, No.3, 2023, pp.194-201,

http://www.jomardpublishing.com/UploadFiles/Files/journals/NMCA/v7n3/Gochuyeva_Hashimov.pdf

9. Hashimov Kh.Kh. T.M. Isayeva, “X-ray graphic study of structural transformations in crystals of $\text{Cu}_{2-x}\text{Ni}_{0.05}\text{S}$ ($x=0.05, 0.25, 0.30$)”. New Materials Compounds and Applications, 2023. Vol.8, No.1, pp.121-134. DOI:<https://doi.org/10.62476/nmca8121>

10. Hashimov Kh.Kh. Synthesis of $\text{Cu}_{2-x}\text{Ni}_{0.05}\text{S}$ ($x=0.05, 0.25, 0.30$) compounds and study of single crystals Asian Journal of Physical and Chemical Sciences, Article no. AJOPACS. 103366 ISSN: 2456-7779. Vol. 11, Issue 3., p.p. 45-51, 2023. DOI: [10.9734/AJOPACS/2023/v11i3205](https://doi.org/10.9734/AJOPACS/2023/v11i3205)

11. Hashimov Kh.Kh. “Investigation of crystal structure and polymorphic transformations of Cu-S system compounds”. V International Scientific and Practical Conference «Modern science: actual problems», Manchester. UK. 66 p., p.p. 55-59, 2023. DOI <https://doi.org/10.5281/zenodo.7950997>

12. Issakov, V.; Bilato, A.; Kurz, V.; Englisch, D.; Geiselbrechtner, A. A highly integrated D-band multi-channel transceiver chip for radar applications. In Proceedings of the 2019 IEEE BiCMOS and Compound Semiconductor Integrated Circuits and Technology Symposium (BCICTS), Nashville, TN, USA, 3–6 November 2019; pp. 1–4

13. Harutyunyan, A.; Sen, P. In-Band Full-Duplex Solutions in the Paradigm of Integrated Sensing and Communication. In Proceedings of the 2023 IEEE International Conference on Acoustics, Speech, and Signal Processing Workshops (ICASSPW), Rhodes Island, Greece, 4–10 June 2023; pp. 1–5.

14. Bozorgi, F.; Sen, P.; Barreto, A.; Fettweis, G. RF front-end challenges for joint communication and radar sensing. In Proceedings of the 2021 1st IEEE International Online Symposium on Joint Communications & Sensing (JC&S), Dresden, Germany, 23–24 February 2021; pp. 1–6

15. E.S. Mammadov The modeling of the two-dimensional potential in the charge-coupled device-structures, AR MEA Fizika, 2002, т. 8, №1, s. 36-38.