

# The Influence of Academic Stress, Lecturer Competence, Campus Facilities, and Learning Environment on Student Cyberloafing Behavior in Purwokerto

## ABSTRACT

**Objective:** This study aims to determine empirically whether academic stress, lecturer competence, campus facilities and learning environment affect *cyberloafing* behavior in students in Purwokerto.

**Type of research:** This type of research is quantitative research. The sampling technique used proportional random sampling technique with the condition that students of universities in Purwokerto include UMP, Unsoed, UIN Saizu, and Telkom and must bring gadgets during lectures.

**Place and time of research:** The research was conducted in Purwokerto from 10 december 2022 to 5 July 2024.

**Methodology:** This research is conducted using a quantitative approach, the data obtained will be processed using SmartPLS software version 3.29. Each hypothesis will be tested using the Inner Model to determine the influence between variables. To test the validity and reliability of the research using the Outer model.

**Results:** The results showed that there is a positive and significant influence between academic stress on cyberloafing behavior, a negative and significant influence between lecturer competence and cyberloafing, a negative but not significant influence on campus facilities and cyberloafing and a positive but not significant influence on the learning environment on cyberloafing behavior.

*Keywords:* Academic Stress, Competence of Lecturers, Campus Facilities, Learning Environment.

## 1. INTRODUCTION

*Cyberloafing* behavior among students is increasingly becoming a concern in the world of higher education. *Cyberloafing* is a person's behavior in using the internet during office hours and these activities are not related to work. (Muhtarom et al., 2021) [1]. In this case, students, or behavior in using the internet for non-academic purposes during lectures.

**Formatted:** Font: 10 pt, Font color: Red, Highlight

**Comment [NA1]:** . . The sources used in the text are indicated as follows: "(Muhtarom et al., 2021)..." etc. Must be: [1],....

**Formatted:** Font: 10 pt, Highlight

The current phenomenon in the field of education in Indonesia is the use of the internet which is currently very accessible to students in Indonesia, especially since the Covid 19 pandemic that occurred in 2020 which makes lectures more often use gadgets and are carried out online. However, this has caused bad habits with the emergence of the *Cyberloafing* phenomenon in students to date. Based on a survey conducted by (Anam et al., 2019) of students at one of the State Universities in Semarang stated that 100% of the students surveyed had committed *Cyberloafing*. Likewise, a survey conducted by (Bela, 2020) on students of the Faculty of Psychology, Diponegoro University Semarang, there were 98, 2% of students who had committed *Cyberloafing*. Furthermore, according to a survey conducted by (Gökçearslan et al., 2016) of a total of 364 students at the University in Ankara of Turkey showed a high average *Cyberloafing* behavior of 68.5%, which means that every 2 out of 3 students have committed *Cyberloafing* behavior. (Blanchard & Henle, 2008) divides *Cyberloafing* behavior into two types, namely (1) Minor *Cyberloafing* refers to the behavior of students in utilizing the internet provided by the campus for things that are not related to academic interests, for example sending or receiving messages, visiting online buying and selling sites, updating the status of social media accounts. In minor *Cyberloafing* behavior can still be tolerated because it does not lead to criminal behavior, even so it does not mean that minor *Cyberloafing* behavior does not have a negative impact such as decreasing student productivity. (2) Serious *Cyberloafing* In this type, students access the internet by using the internet provided by the campus for dangerous purposes because it has the potential to commit illegal acts, even criminalization. Such as online gambling, downloading songs or videos illegally, and accessing pornographic sites. Which of course has a detrimental impact on the campus and students themselves. Therefore, researchers conducted a preliminary study to determine the situation related to *Cyberloafing* behavior in students in Purwokerto, because *Cyberloafing* behavior is one of the negative impacts of technological development and the internet. This research was also conducted based on the author's unrest about *Cyberloafing* behavior that the author encountered directly during the lecture process. Therefore, the authors conducted this study with the aim of knowing empirically how much influence academic stress, lecturer competence, campus facilities, and learning environment on *Cyberloafing* behavior of students in Purwokerto.

Many factors encourage why students do *Cyberloafing*, the first is Academic Stress. Academic stress refers to a subjective perception of students' academic condition or response in the form of physical reactions, behavioral reactions, negative thoughts and emotions triggered by a lecture or academic pressure, Boyraz & Legrosin (Oktariani et al., 2021). Purwati & Amaliain (Bakri, 2021) said that the academic stress that students experience arises from their learning experience or learning activities related things, such as the pressure to enter the next semester, length of study, demands for many assignments, competition, failure and poor relationships with friends, lecturers or family members. However, there are different views on previous research regarding the effect of academic stress on the behavior of *Cyberloafing*. Such as research conducted by (Hibrian, 2021), (Simatupang & Margaretha, 2023) stated that academic stress positively and significantly affects *Cyberloafing* behavior. Meanwhile, research carried out by (Kusumawardani, 2022) revealed that the correlation between academic stress and the behavior of *Cyberloafing* was in the moderate category. While the research carried out by (Wiastuti et al., 2022) found that the relationship between job stress and *Cyberloafing* has a low but positive and significant relationship.

Lecturer competence can also affect *Cyberloafing* behavior in students. According to Lawno. 14 of 2005 concerning teachers and lecturers states that lecturer competence involves knowledge, skills and behaviors that lecturers must own, live and master in carrying out their professional duties. Danim in (Murti & Prasetyo, 2018) stated that there are four factors that can be used to measure lecturer competency variables. First, pedagogical competence, which includes lecturers' ability to construct learning systems and materials. Second, personality competence, which refers to lecturers' attitudes and actions throughout the teaching and learning process. Third, social competence, which includes lecturers' skills in interacting and communicating with students, superiors, friends, and the community. Fourth, professional competence, which refers to the extent to which lecturers understand and master learning materials. Since there is no specific previous research on the topic under study, the authors refer to the closest previous research, one of which is research conducted (Alanoğlu & Karabatak, 2021) found that there is a significant and negative relationship between attitudes towards learning and cyberloafing. And research conducted (Farhad, 2023) found that Self Direct Learning and student media literacy have a negative effect on cyberloafing. Then according to research conducted (Sucipto et al., 2023) shows that there is a significant negative relationship between cyberloafing and employee performance.

According to (Victor & Selvia, 2022), facilities are the infrastructure and environment's appearance and functionality in showing their presence to outsiders which include physical structures, equipment, tools, objects, financial resources, and workplace areas. Facilities and infrastructure, environmental area, lighting and noise also have a major influence in making the learning environment pleasant, which can influence both motivation and learning process of students. Comfortable classroom conditions will help students to have better concentration, get optimal learning results, and enjoy their learning process (Aruan, 2020). There is also no previous research that is specific to these variables, so the author again refers to the closest previous research to the effect of campus facilities on cyberloafing behavior. According to research conducted (Ahmad & Jamaluddin, 2010) concluded that the effect of computer and internet facility policies on cyberloafing is still minimal among Malaysian employees. Likewise, the results related to cyberloafing said by (Bagis et al., 2024) reveal that internet access does not necessarily have an impact on employees.

Baharuddin's opinion in (Jurnal Tarbiyah, 2018) provides an illustration that external factors, such as learning environment, play a role in influencing the development of each student in the learning process. Learning environment requires not only excellent facility, but also needs to provide comfort and tranquility in the environment to help students maintain focus on their lessons. A good learning environment according to Saifuddin's view in (Jurnal Tarbiyah, 2018) suggests a stimulating and challenging environment for learning, which also provides a sense of security, peace and satisfaction for students to achieve the expected or satisfying learning results. Dariyo in (Damanik, 2019) said that a positive classroom atmosphere will occur if classroom interactions occur between lecturers and students, where in these interactions there is communication in the form of learning together, helping each other, tolerance between clever and less clever students, between the rich and the less capable, the norms of social life and classroom and campus rules are obeyed with flexible facilities, and open communication occurs. Due to the limited previous research on the influence of the learning environment with *Cyberloafing*, the authors will refer to the closest previous research to the influence of the learning environment with *Cyberloafing* behavior.

According to research conducted by (Benedita, 2018), work environment significantly influences *Cyberloafing* behavior. According to (Jurnal Tarbiyah, 2018), a very significant and positive correlation is found between learning environment and the achievement of students. Meanwhile, according to (Prawidia & Khusna, 2021), learning environment shows an impact on students' interest in mathematics learning outcomes by 32.3% simultaneously. Meanwhile, research conducted (Aruan, 2020) said that no significant relationship was found between the learning environment and learning achievement.

There are several studies that examine *Cyberloafing*, but of course each place has different characteristics regarding the topic. Be it the factors that cause it, who is involved and the indicators used. In addition, the focus of the problem on the influence of academic stress, lecturer competence, campus facilities, and the learning environment on *Cyberloafing* behavior in students in Purwokerto has never been studied, so it is necessary to conduct empirical research to determine whether academic stress, lecturer competence, campus facilities, and the learning environment affect *Cyberloafing* behavior in students in Purwokerto.

## 2. LITERATURE REVIEW THEORY [2.1](#)

### Theory of Planned Behavior

Theory Of Interpersonal Behaviour (Triandis, 1980) helps in identifying factors that influence *Cyberloafing* behavior. The theory explains that adopting a particular behavior is the result of intentions, habits, and supportive conditions. TIB has an advantage over the Theory Of Planned Behaviour (TPB) model because it also includes habit as an important construct. Therefore, for the current study, the TIB model was used to predict the factors that influence *Cyberloafing* in students in Purwokerto. Research by (Woon & Pee, 2004) validating the (Triandis, 1980) model while studying *Cyberloafing* in organizations found that intention, social factors, and habits are the main causes of *Cyberloafing* behavior. The factors reported above impact students' behavioral intentions and consequently these intentions lead individuals to adopt *Cyberloafing* behavior.

### [2.2](#) The Influence of Academic Stress on *Cyberloafing* Behavior

In the Theory Of Interpersonal Behaviour, there are social factors or supportive conditions that are said to influence *Cyberloafing* behavior. Where this is related to academic stress. Academic stress is a subjective perception of an academic condition or response experienced by students in the form of physical reactions, behavioral reactions, negative thoughts and emotions that arise due to a lecture or academic demand, Boyraz & Legros in (Oktariani et al., 2021)

However, there are different views in previous studies regarding academic stress' effect on the behavior of *Cyberloafing*. Such as research carried out by (Wastuti et al., 2022) and (Simatupang & Margaretha, 2023) stated that academic stress positively and significantly impacts *Cyberloafing* behavior. Meanwhile, research carried out by (Kusumawardani, 2022) revealed that the correlation between academic stress and *Cyberloafing* behavior was in the moderate category but positive and significant. While research conducted (Hibrian, 2021) found that the relationship between academic stress and *Cyberloafing* has a positive relationship. The hypothesis related to this is put forward as follows:

**H1:** Academic stress has a significant positive effect on *Cyberloafing* behavior.

### **2.3 The Influence of Lecturer Competence on Cyberloafing Behavior**

In Theory Of Interpersonal Behaviour, there are social factors or supportive environmental conditions that are said to influence Cyberloafing behavior, and this is also related to the lecturer competency variable. According to Law no. 14 of 2005 concerning teachers and lecturers states that lecturer competence is a set of knowledge, skills and behaviors that must be owned, lived and mastered by lecturers in carrying out professional duties.

Because there is no specific previous research on the topic under study, the authors refer to the closest previous research, one of which is research conducted (Alanoğlu & Karabatak, 2021) found that there is a significant and negative relationship between attitudes towards learning and cyberloafing. And research conducted (Farhad, 2023) found that Self Direct Learning and student media literacy have a negative effect on Cyberloafing. Then according to research conducted (Sucipto et al., 2023) shows that there is a significant negative relationship between cyberloafing and employee performance.

**H2:** Lecturer competence has a negative and significant effect on cyberloafing behavior.

### **2.4 The Influence of Campus Facilities on Cyberloafing Behavior**

Campus facilities are also related to Theory Of Interpersonal Behaviour, namely social factors or conditions that support Cyberloafing, because the easier the internet is accessed, the more likely students are to carry out Cyberloafing behavior. According to (Victor & Selvia, 2022) Facilities are the appearance, ability of infrastructure facilities and the state of the surrounding environment in showing its existence to external which includes physical facilities, equipment and equipment. Which includes facilities in the form of tools, objects, equipment, money, workplace space.

There is also no previous research that is specific to these variables, so the authors again refer to previous research that is closest to the effect of campus facilities on cyberloafing behavior. According to research conducted (Ahmad & Jamaluddin, 2010) concluded that the effect of computer and internet facility policies on cyberloafing is still minimal among Malaysian employees. Likewise, the results related to Cyberloafing said by (Bagis et al., 2024) revealed that internet access does not necessarily have an impact on employees.

**H3:** Campus facilities have a negative and insignificant effect on cyberloafing behavior.

### **2.5 The Influence of Learning Environment on Cyberloafing Behavior**

The Learning Environment is also related to the Theory Of Interpersonal Behaviour about social factors or supportive conditions that are said to influence Cyberloafing behavior. Dariyo in (Damanik, 2019) says that a positive classroom atmosphere will occur if classroom interactions occur between lecturers and students, where in these interactions there is communication in the form of learning together, helping each other, tolerance between clever and less clever students, between the rich and the less capable, the norms of social life and classroom and campus rules are obeyed with flexible facilities, and open communication occurs.

Due to the limited previous research on the influence of the learning environment with Cyberloafing, the authors will refer to the closest previous research to the influence of the learning environment with Cyberloafing behavior. According to research conducted by (Ria Benedita, 2018) states that there is a positive but insignificant effect of the work environment on Cyberloafing behavior. Research conducted (Aruan, 2020) said that no significant relationship was found between the learning environment and learning achievement. Meanwhile, according to (Prawidia & Khusna, 2021), it states that there is an effect of the learning atmosphere environment on student interest in learning mathematics learning outcomes but only by 32.3% simultaneously. Meanwhile, research conducted (Jurnal Tarbiyah, 2018) There is a significant positive relationship between the learning environment

and student learning achievement. Based on the previous research above, the hypothesis found is as follows.

**H4:** The learning environment has a positive and insignificant effect on cyberloafing behavior

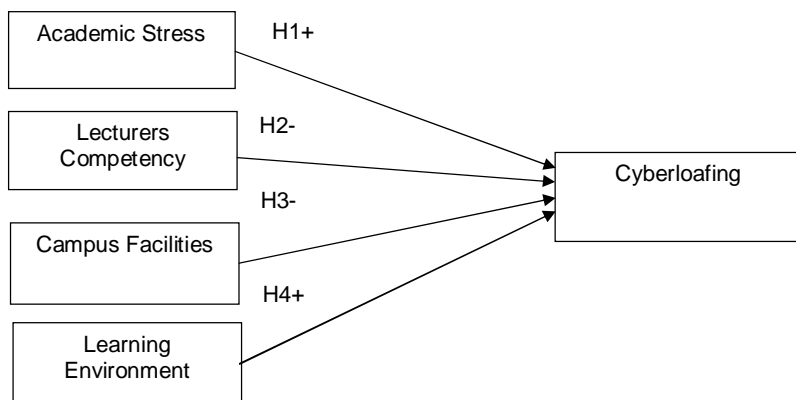

figure Fig. 1. Research framework

### 3. RESEARCH METHODS

This research was conducted using a quantitative approach, which is research that uses the method of empirical statements which are usually expressed in numbers. Data was obtained through a questionnaire method that was distributed offline. Measurement of each indicator of each variable using a Likert scale. The population of this study were students from Purwokerto Universities including Muhammadiyah Purwokerto University, Jenderal Soedirman University, Telkom Institute of Technology Purwokerto, and UIN Saizu Purwokerto with a total population of 51,344 students. Due to the large population, researchers used the Slovin formula approach with an error rate of 0.1 to calculate the sample. After calculating using the slovin formula, the minimum sample number was 99.86 which was rounded up to 100 people. The sampling technique in this study used Proportional Random Sampling technique. The data obtained will be analyzed using statistical data analysis assisted by computer applications in the form of Smart PLS Version 3.29.

The population size  $N = 51,344$  is known that 25% are students of Muhammadiyah Purwokerto University, 15% of Jenderal Soedirman University, 40% of Telkom Institute of Technology, and 20% of Purwokerto State Islamic University and will be taken using the Slovin formula at the significance level  $\alpha = 0.1$  then proportionally, the sample size for each level of education is as follows:

Table 1. .... 2

University	Percentage	Sample Size	
		Slovin	Results
UMP	36%	$36\% \times 100$	36

Formatted: Highlight

Formatted: Left

Unsoed	42%	42% x 100	42
IT Telkom	9%	9% x 100	9
UIN Saizu	13%	13% x 100	13
Total	100%		100

#### 4.3.1 Variable Operationalization Table

**Table 2.....?**

No.	Variable	Indicator	Measurement Scale
1.	Cyberloafing (y)	<ul style="list-style-type: none"> <li>• Minor Cyberloafing               <ul style="list-style-type: none"> <li>a. Sending messages</li> <li>b. Receiving messages</li> <li>c. Visiting online shop sites</li> <li>d. Updating social media status</li> </ul> </li> <li>• Serious Cyberloafing               <ul style="list-style-type: none"> <li>a. Online gambling</li> <li>b. Downloading illegal videos</li> </ul> </li> </ul>	Ordinal
2.	Academic Stress (x1)	<ul style="list-style-type: none"> <li>• Pressure</li> <li>• Competition</li> <li>• Failure</li> </ul>	Ordinal
3.	Lecturers Competence (x2)	<ul style="list-style-type: none"> <li>• Pedagogical competence</li> <li>• Personal competence</li> <li>• Social competence</li> <li>• Professional competence</li> </ul>	Ordinal
4.	Campus Facilities (x3)	<ul style="list-style-type: none"> <li>• Physical facilities</li> <li>• Environmental area</li> <li>• Lighting</li> <li>• Noise</li> <li>• Wifi network</li> <li>• Communication between lecturers and students</li> </ul>	Ordinal
5.	Learning Environment (x4)	<ul style="list-style-type: none"> <li>a. Studying together</li> <li>b. Help each other</li> <li>c. Tolerance</li> <li>• Class Rules</li> </ul>	Ordinal

Formatted: Outline numbered + Level: 2 + Numbering Style: 1, 2, 3, ... + Start at: 1 + Alignment: Left + Aligned at: 0.82" + Indent at: 1.07"

Formatted: Highlight

## 5.4. RESULTS

### 4.1 Image of outer loading output

This analysis uses the Smart-PLS version 3.29 program analysis software.

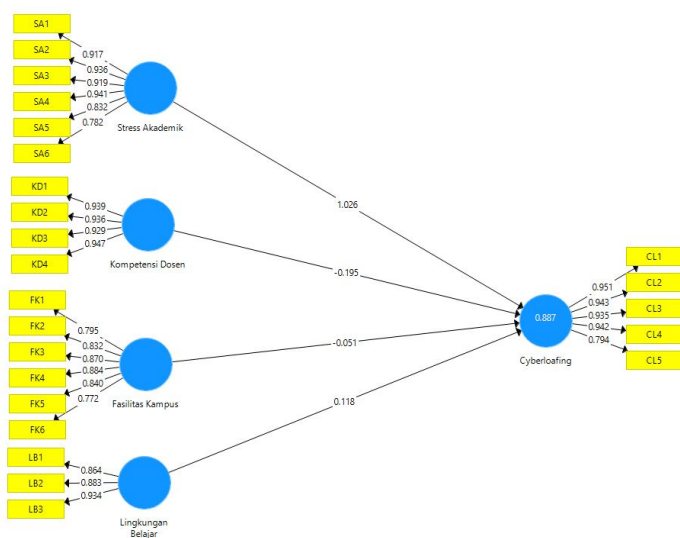

Fig. 2. Figure 1 Structural mode

Source: Processed by Researchers (2024)

*Outer Loading* is valid if the value is above 0,7 (Ghozali, 2016). Based on the figure above illustrates that there are 6 items that measure Academic Stress, and all of these items are said to be valid because *Outer loading is* above 0.7. Lecturer Competence is measured by 4 questions and all of these items are declared valid because *Outer Loading is* above 0.7. Campus Facilities were measured with 6 questions and all statements were declared valid. Learning Environment is measured by 3 questions and all of these questions are deemed valid with *Outer Loading exceeding* 0.7.

Formatted: Font: 10 pt

Formatted: Font: Bold

#### 4.2 Outer Model Results

**Table 3. Validity Test**

Variables	Item	Outer Loading Factor	Average Variance (AVE)	Description
Academic Stress (X1)	SA1	0.917	0.791	Valid
	SA2	0.936		Valid
	SA3	0.919		Valid
	SA4	0.941		Valid
	SA5	0.832		Valid
	SA6	0.782		Valid
Lecturer Competence (X2)	KD1	0.939	0.879	Valid
	KD2	0.936		Valid
	KD3	0.929		Valid
	KD4	0.947		Valid
Campus Facilities (X3)	FK1	0.795	0.694	Valid
	FK2	0.832		Valid
	FK3	0.870		Valid
	FK4	0.884		Valid
	FK5	0.840		Valid
	FK6	0.772		Valid
Learning Environment (X4)	LB1	0.864	0.800	Valid
	LB2	0.883		Valid
	LB3	0.934		Valid
Cyberloafing Behavior (Y)	CL1	0.951	0.837	Valid
	CL2	0.943		Valid
	CL3	0.935		Valid
	CL4	0.942		Valid
	CL5	0.794		Valid

Source: Processed by Researchers (2024)

According to the table presented above, the loading factor of Academic Stress, Lecturer Competence, Campus Facilities, Learning Environment, and Cyberloafing Behavior exceeds 0.7. This can explain that the indicators used to measure constructs can be declared valid and have met the convergent validity test. To see the results of Average Variance Extracted (AVE) on the variables of Academic Stress, Lecturer Competence, Campus Facilities, Learning Environment, and Cyberloafing Behavior, AVE value should be above 0.5 (Ghozali & Latan, 2015). Each variable is considered valid because the AVE (Average Variance Extracted) value exceeds 0.5.

Formatted: Left

**Table 4. Fornell-Larcker**

	Cyberloafing	Campus Facilities	Lecturer Competency	Learning Environment	Academic Stress
Cyberloafing	0.928				
Campus Facilities	0.545	0.830			
Lecturer Competency	0.754	0.540	0.940		
Learning Environment	0.867	0.655	0.807	0.891	
Academic Stress	0.938	0.584	0.850	0.907	0.886

Source: Processed by Researchers (2024)

Discriminant validity tests can be determined by observing the *Fornell-Larcker* value. According to the table presented above, the square root of the AVE exceeds the latent variable correlation. Therefore, the discriminant validity test is acceptable.

**Table 5. Reliability Test**

Variables	Cronbach's alpha	Composite Reliability
Academic Stress (X1)	0.945	0.956
Lecturer Competence (X2)	0.956	0.968
Campus Facilities (X3)	0.912	0.930
Learning Environment (X4)	0.870	0.920
Cyberloafing Behavior (Y)	0.968	0.974

Source: Processed by Researchers (2024)

The reliability test is determined using the *composite reliability* and *Cronbach's alpha* numbers with numbers equal to or exceeds 0.60 (Ghozali, 2016). Based on the table above, it shows that the *Cronbach's alpha* and *composite reliability* numbers for all variables exceed 0.70. Therefore, all variables used in this research model meet the reliability requirements so that they can be declared reliable.

Formatted: Left

Formatted: Left

### 4.3 Inner Model Results

**Table 6. R-Square Test**

Construct	RSquare	RSquareAdjusted
Cyberloafing	0.882	0.884

Source: Processed by Researchers (2024)

There are 3 categories, as stated by (Chin, 1998). If the R-Square value is > 0.67, this category is considered strong, if the score is more than 0.33 it is considered moderate, but if the score is less than 0.67, if the R-Square value exceeds 0.19 it is considered part of the weak category. After using SmartPLS, the R-Square result above is 0.882 from the table above, the result of the R-Square value of 0.882 is classified as strong because it exceeds 0.67.

**Table 7. Path Coefficients**

	Original Sample (O)	Sample Mean (M)	Standard Deviation (STDEV)	T Statistics ( O / STDEV )	P Values	Hypothesis
Campus Facilities > Cyberloafing	-0.051	-0.050	0.043	1.196	0.232	Accepted
Lecturer Competency > Cyberloafing	-0.195	-0.185	0.091	2.141	0.033	Accepted
Learning Environment > Cyberloafing	0.118	0.135	0.098	1.206	0.121	Accepted
Academic Stress > Cyberloafing	1.026	1.000	0.103	9.949	0.000	Accepted

Source: Processed by Researchers (2024)

The criteria for the Path Coefficient t-statistic value is > 1.96 and a hypothesis can be said to be significant if the significance value (P Value) < 0.05 (Azuar Juliandi, 2018)

### 6-5. DISCUSSION

The results of this study indicate that academic stress has a positive and significant effect on cyberloafing behavior. This is in line with research conducted by (Dyah Wiastuti et al., 2022), (Simatupang & Margaretha, 2023) and (Liya Kusumawardani, 2022) which state that academic stress has a positive and significant effect on Cyberloafing behavior. In this case, academic stress contributes maximally to making students do cyberloafing behavior.

Second, this study also shows that lecturer competence has a negative and significant effect on cyberloafing behavior. This is also in line with research conducted (Alanoğlu & Karabatak, 2021) found that there is a significant and negative relationship between attitudes towards learning and cyberloafing. And research conducted (Farhad, 2023) found that Self Direct Learning and student media literacy have a negative effect on Cyberloafing. Then according to research conducted (Sucipto et al., 2023) shows that there is a significant negative relationship between cyberloafing and employee performance.

Third, the results showed that campus facilities have a negative but insignificant effect on cyberloafing behavior. This means that these results are in accordance with research

Formatted: Left

Formatted: Left, Indent: Left: 0.82"

conducted (Ahmad & Jamaluddin, 2010) which concluded that the effect of computer and internet facility policies on cyberloafing is still minimal among Malaysian employees. Likewise, the results related to Cyberloafing said by (Bagis et al., 2024) reveal that internet access does not necessarily have an impact on employees.

Fourth, the results of this study indicate that the learning environment has a positive but insignificant effect on cyberloafing. The results of this study are in line with research conducted by (Ria Benedita, 2018) which states that there is a positive but insignificant effect of the work environment on Cyberloafing behavior.

## **7-6. CONCLUSION**

Based on the results of this study, not all determinant variables have a positive and significant effect on cyberloafing behavior. Academic Stress has a positive and significant effect on Cyberloafing behavior. Lecturer competence has a negative and significant effect on cyberloafing behavior. Campus facilities have a negative but insignificant effect on cyberloafing behavior. And the learning environment has a positive but insignificant effect on cyberloafing behavior.

The results of this study provide empirical evidence in terms of the direct and indirect impact of the variables of Academic Stress, Lecturer Competence, Campus Facilities, and Learning Environment, on Cyberloafing Behavior in students in Purwokerto. The results of this study can contribute to the development of Cyberloafing behavior theory and can also be used to help solve Cyberloafing behavior problems.

There are still some imperfections in this study that might be improved, one of which is that the coverage area is not too large so that the resulting data cannot reflect accurate and maximum results from actual conditions. And also the limited variables studied, therefore future similar researchers can also consider that and also use research objects in other cities or on a larger scale such as provincial coverage or others.

The implications of these findings provide important insights for educational organizations to design effective strategies to reduce cyberloafing and increase the productivity of their employees and students. By understanding the factors that drive cyberloafing, educational organizations and others can build on this research to create a positive learning environment.

This study provides a strong basis for further research on cyberloafing in Higher Education. Some suggestions for future research include:

1. Longitudinal Study: Conduct longitudinal studies to understand changes in cyberloafing behavior over time.
2. Additional Variables: Research additional variables that may influence cyberloafing, such as student satisfaction, or academic achievement.
3. Demographic Differences: Examine how demographic factors like gender, age, and job title shape patterns of cyberloafing behavior.
4. Multicultural Approach: Comparing cyberloafing behavior across different cultures and countries to understand differences in norms and attitudes toward cyberloafing.

Thus, the findings of this research contribute not only to the academic literature, but also have practical implications that can be applied by organizational management to create a more productive and ethical learning environment.

## REFERENCES

- Ahmad, Z., & Jamaluddin, H. (2010). *Computer usage policy and employees' attitude towards cyberloafing*.  
<https://www.researchgate.net/publication/270730235>
- Alanođlu, M., & Karabatak, S. (2021). Examining of the Smartphone Cyberloafing in the Class: Relationship with the Attitude towards Learning and Prevention of Cyberloafing. *International Journal of Technology in Education*, 351–372.  
<https://doi.org/10.46328/ijte.84>
- Anam, K., Arista Pratomo, G., Psikologi, J., & Artikel, S. (2019). *Fenomena Cyberslacking Pada Mahasiswa*.  
<http://journal.unnes.ac.id/nju/index.php/INTUISI>
- Aruan, J. (2020). *Pengaruh Regulasi Diri dan Lingkungan Belajar Terhadap Prestasi Belajar*. 8(1), 83–89.
- Azuar Juliandi. (2018). *Structural Equation Model Partial Least Square (Sem-Pls) Dengan Smartpls*. <https://doi.org/10.5281/zenodo.1243777>
- Bagis, F., Darmawan, A., Pratamasari, M. A., & Marifatul U, J. P. (2024). Restraining Cyberloafing Behavior in Private Hospital Employees: Analysis of Work Stress Factors and Locus of Control. *Asian Journal of Economics, Business and Accounting*, 24(6), 181–191. <https://doi.org/10.9734/ajeba/2024/v24i61352>
- Bahrudi Effendi Damanik. (2019). *Pengaruh Fasilitas Dan Kompetensi Dosen Terhadap Motivasi Belajar*. 2.
- Blanchard, & Henle. (2008). *The Interaction of Work Stressors and Organizational Sanctions on Cyberloafing*. <https://www.jstor.org/stable/40604617>
- Chin, W. W. (1998). The partial least squares approach for structural equation modeling. In G. A. Marcoulides (Ed.), *Lawrence Erlbaum Associates Publishers*, 295–336.
- Dyah Wiastuti, R., Prawira, O., & Yulianti, D. (2022). *The Influence of Hotel Employee Job Stress towards Cyberloafing*. 5(1).  
<https://doi.org/10.17509/jithor.v>
- Farhad. (2023). Modeling the Role of Self-Directed Learning and Media Literacy Factors in Students' Cyberloafing with Artificial Neural Network Approach. In *Journal of Higher Education Curriculum Studies* (Vol. 13, Issue 26).
- Ghozali. (2016). *Aplikasi Analisis Multivariate SPSS 23*.  
[https://www.researchgate.net/publication/301199668\\_Aplikasi\\_Analisis\\_Multivariate\\_SPSS\\_23](https://www.researchgate.net/publication/301199668_Aplikasi_Analisis_Multivariate_SPSS_23)
- Ghozali, & Latan. (2015). *Partial Least Squares: Konsep, Teknik dan Aplikasi Menggunakan Program SmartPLS 3.0, -2/E*.  
<https://openlibrary.telkomuniversity.ac.id/pustaka/117046/partial-least-squares-konsep-teknik-dan-aplikasi-menggunakan-program-smartpls-3-0-2-e.html>
- Gökçearsan, Ş., Mumcu, F. K., Haşlaman, T., & Çevik, Y. D. (2016). Modelling smartphone addiction: The role of smartphone usage, self-regulation, general self-efficacy and cyberloafing in university students. *Computers in Human Behavior*, 63, 639–649. <https://doi.org/10.1016/j.chb.2016.05.091>
- Hibrian, H. (2021). *Hubungan Stres Akademik Dengan Perilaku Cyberloafing Pada Mahasiswa Psikologi Universitas Pendidikan Indonesia Bandung*.
- Jurnal Tarbiyah. (2018). Kontribusi Lingkungan Belajar Dan Proses Pembelajaran Terhadap Prestasi Belajar Siswa Di Sekolah Petunjuk Pengisian Kuesioner. *JURNAL TARBIYAH*, 25(2). <https://doi.org/10.30829/tar.v25i2.365>

Comment [NA2]: References should be checked.

- . The sources used in the text are indicated as follows: "(Muhtarom et al., 2021)..." etc. Must be: [1],....
- . All works cited in the text must be listed in the References.
- . to elaborate the bibliographic citation and references format according to the needs of AJESS

- Krisma Bela. (2020). *Hubungan Antara Kepribadian Extraversion Dengan Cyberslacking pada Fakultas Psikologi Universitas Diponegoro Semarang*.
- Liya Kusumawardani. (2022). *Hubungan Stres Akademik dengan Perilaku Cyberloafing pada Mahasiswa HUBUNGAN STRES AKADEMIK DENGAN PERILAKU CYBERLOAFING PADA MAHASISWA Liya Kusumawardani Dinarti Yohana Wuri Satwika*.
1. Muhtarom, A., Suprpto, H., Sa, F., & oleh Politeknik Dharma Patria Kebumen, D. (2021). *Jurnal E-Bis (Ekonomi-Bisnis) Pengaruh Locus Of Control, Organizational Commitment, Dan Perilaku Cyber loafing Terhadap Kinerja Pegawai Di Era Kebiasaan Baru (Studi Pada Pegawai Perumda BPR. Bank Daerah Lamongan)*. 2021;5(1): 115–125. <https://doi.org/10.37339/jurnal>
- Oktariani, I. S., S.Rahmi, & Putri, R. M. (2021). Tingkat Stress Akademik Mahasiswa dalam Pembelajaran Daring pada Periode Pandemi Covid-19. *Journal of Learning and Instructional Studies*, 1(1), 17–24. <https://doi.org/10.46637/jlis.v1i1.3>
- Prawidia, I., & Khusna, H. (2021). Pengaruh Suasana Lingkungan Belajar Dan Minat Belajar Siswa Terhadap Hasil Belajar Matematika. In *Jurnal Penelitian Pembelajaran Matematika* (Vol. 14). Hikmatul Khusna.
- Purwanto Bakri, R. (2021). *Pengaruh Stres Akademik dan Kecanduan Smartphone Terhadap Prokrastinasi Akademik*. <https://doi.org/10.30872/psikoborneo>
- Ria Benedita. (2018). *Pengaruh beban kerja, peran ganda, dan lingkungan kerja terhadap perilaku cyberloafing pegawai*.
- Ridyantoro Widoyo Murti, & Arif Partono Prasetyo. (2018). Pengaruh kompetensi dosen terhadap prestasi akademik mahasiswa ekonomi dan bisnis telkom university. *Jurnal Mahasiswa Manajemen*.
- Simatupang, K. M., & Margaretha, M. (2023). The Impact of Academic Stress on Cyberloafing with Fatigue as a Mediating Variable: A Study of Students in Bandung City-Indonesia During a Pandemic. *European Journal of Educational Research*, 12(1), 525–535. <https://doi.org/10.12973/eu-jer.12.1.525>
- Sucipto, I., Heri Kusumah, D., Pelita Bangsa, U., & Author, C. (2023). Towards Optimal Performance: Overcoming Cyberloafing Challenges With Strong Organizational Commitment And Work Discipline Menuju Kinerja Optimal: Mengatasi Tantangan Cyberloafing Dengan Komitmen Organisasi Dan Disiplin Kerja Yang Kuat. In *Management Studies and Entrepreneurship Journal* (Vol. 4, Issue 6). <http://journal.yrpioku.com/index.php/msej>
- Triandis. (1980). *Values, attitudes, and interpersonal behavior*. <https://pubmed.ncbi.nlm.nih.gov/7242748/>
- Victor, & Selvia. (2022). *Pengaruh Fasilitas Kampus dan Lingkungan Kampus Terhadap Motivasi Belajar Mahasiswa Program Studi Manajemen STMB MULTISMART Medan Victor 1. Selvia 2 Program Studi Manajemen ST Manajemen Bisnis Multi Sarana Manajemen Administrasi dan Rekayasa Teknologi Medan*. <http://ejournal.urindo.ac.id/index.php/administrasimanajemen/index>
- Woon, & Pee. (2004). *Behavioral Factors Affecting Internet Abuse in the Workplace – An Empirical Investigation*. <https://www.semanticscholar.org/paper/Behavioral-Factors-Affecting-Internet-Abuse-in-the-Woon-Pee/0ff825dc69968c97fad79e018fa0737a639082f4>

Formatted: Font: (Default) Arial MT, 11 pt, Not Bold, Highlight

Formatted: Font: (Default) Arial MT, 11 pt, Not Bold, Highlight

Formatted: Font: (Default) Arial MT, 11 pt, Not Bold, Not Italic, Highlight

Formatted: Font: (Default) Arial MT, 11 pt, Not Bold, Highlight