

Application of Artificial Neural Networks in Soil Science research

ABSTRACT

Artificial Neural Networks utilize high-performance computation and large data technology, allowing research to generate new prospects in agriculture. ANN is currently a preferred technique for crop yield prediction, forecasting, and classification in biological science domains. Among different agriculture fields, soil science research plays a vital role in understanding and managing the complex processes occurring within the soil environment as soil is a complex system with dynamic surface layers that differ from the other parts of the matrix. Due to the increasing accessibility of innovative computing techniques, Artificial Neural Networks (ANNs) have developed into useful tools for modeling and forecasting soil-related activities. The numerous applications of ANNs in soil science research, with a focus on how well they can classify soils, assess soil fertility, forecast soil erosion, and estimate soil moisture. They are vital tools for identifying soil types, evaluating fertility levels, predicting erosion, and soil moisture estimation. ANN models were effective at predicting soil characteristics like pH, organic carbon concentration, and clay content. By training on vast datasets that contain the chemical, biological, and physical properties of soil, ANNs are able to accurately predict different soil types and enable land-use planning, precision farming, and environmental management. This mini-review focuses on ANN approaches that possess the potential to increase our understanding of soil science and encourage informed decisions for soil management and conservation.

Keywords: ANN, input-output, Prediction, Accuracy, soil properties, precision agriculture

1. INTRODUCTION

The main focus of soil mechanics challenges is on a few soil types that exhibit unpredictable behaviors in the natural environment. It can be challenging and occasionally difficult to model soil behavior utilizing the majority of traditional physically-based engineering techniques. Artificial neural networks (ANN) are used to predict the complex characteristics of the soil since they have shown to be more accurate predictors than conventional methods. An enormous amount of attention has been generated by ANN as effective tools for modeling and forecasting intricate soil dynamics [1].

An enhanced learning algorithm known as a "Artificial neural network" (ANN) was developed in response to the study of biotic neural networks in humanoid brains. Here, the human brain is attempted to be mimicked. Even though they are referred to as artificial intelligence, artificial neural networks can only be employed with structured and numeric data as input. They are made up of a network of artificial neurons that can identify patterns in data, learn from it, and provide classifications or predictions. It is a potent technique for predicting and categorizing many physical, chemical, and biological traits of soil types. By training on large collections of data that contain samples of soil and related properties, ANNs are effectively able to capture the intricate spatial and temporal changes of soil parameters. ANN assists in understanding the characteristics of soil, producing precise forecasts, and applying this knowledge to guide decisions about land use, agriculture, and environmental preservation [2].

ANN provides a strong and adaptable method for tackling numerous difficulties in soil science research. Their promise to revolutionize soil management practices, boost agricultural output, and encourage sustainable land use is based on their capacity to model complicated interactions, anticipate soil attributes, and support informed decision-making. Researchers can gain new insights into soil science and help to improve soil conservation and environmental

stewardship by investigating and improving ANN techniques. This mini review focuses on publications about ANN applications, which are main success stories in the field of soil science.

2. ANN: AN EFFECTIVE TOOL FOR AGRICULTURE

Modern agriculture requires high production efficiency while also producing high-quality products. This is applicable to both crop and livestock production. To address these criteria, new data analysis approaches, particularly those based on artificial intelligence, are becoming increasingly popular.

“Artificial neural networks (ANNs) are one of the most often used techniques of this type. They are commonly utilised to solve various categorization and prediction tasks. They have long been employed in the broader realm of agriculture. They can be used in precision farming and decision-support systems. Artificial neural networks are one of the primary alternatives to standard mathematical models” [3]. “They commence as a new tool for analysis of the fuzzy geotechnical problems” [4]. “They are one of the most important elements of machine learning and artificial intelligence. The spectrum of neural networks application is very wide, and it also includes agriculture” [3]. “ANNs are interesting due of their information processing features, including nonlinearity, high parallelism, fault tolerance, learning, and generalisation capability” [5].

“Various types of artificial neural networks were applied in solving relevant tasks and problems widely found in agriculture. In the field of pest control, artificial neural networks were developed to identify grain weevil in wheat kernels using four features mass, equivalent diameter, humidity, and hardness” [6]. “ANNs were adopted to examine the impact of the variety and weather conditions on the concentration of ferulic acid, deoxynivalenol, and nivalenol in winter wheat grain” [7]. “The ANN-based ongoing classification method was used to solve a variety of prospective classification tasks in agriculture. The method relies on memory storage and retrieval and combines a convolutional neural network (CNN) and a generative adversarial network (GAN). This approach was evaluated for two classification problems: identifying crop pests and plant leaves” [8].

“Artificial neural networks were applied to model the dynamic reactions of plant growth to changes in root zone temperature in hydroponic chilli pepper plants” [9]. “Neural network models were used to estimate the corn grain yield using six vegetation indices (NDVI, NDRE, WDRVI, EXG, TGI, VARI), canopy cover, and plant density. The characterization and estimation of maize grain production were made possible by collecting spectral data using remote sensors installed on an unmanned aerial vehicle and then processing it in terms of vegetation indices, canopy cover, and plant density” [10]. ANN is currently a preferred technique for crop yield prediction, forecasting, and classification in biological science domains. Regression models take more time to design, but an ANN model can forecast crop yields more accurately than regression models. There are many variables that affect agricultural productivity, and it will be shown how to utilize ANN to predict crop yield utilizing both direct and indirect variables [11].

2.1. Architecture of an artificial neural network

“The ANNs architecture comprises a sequence of processing elements or nodes” [12]. “A neural network consists of a large number of artificial neurons, which are termed units arranged in a sequence of layers. Artificial Neural Network primarily consists of three layers namely Input, Hidden and Output Layers. Input Layer accepts inputs in several different formats provided by the programmer. It serves as the network's primary source of raw data. The hidden layer presents in-between input and output layers. It performs all the calculations to find hidden features and patterns and acts on the input and weights from the layer before it by applying a non-linearity before sending the results to the output layer. Output layer collects and transmits the information in a planned manner. The input goes through a series of transformations using the hidden layer, which finally results in output” [13, 14, 15].

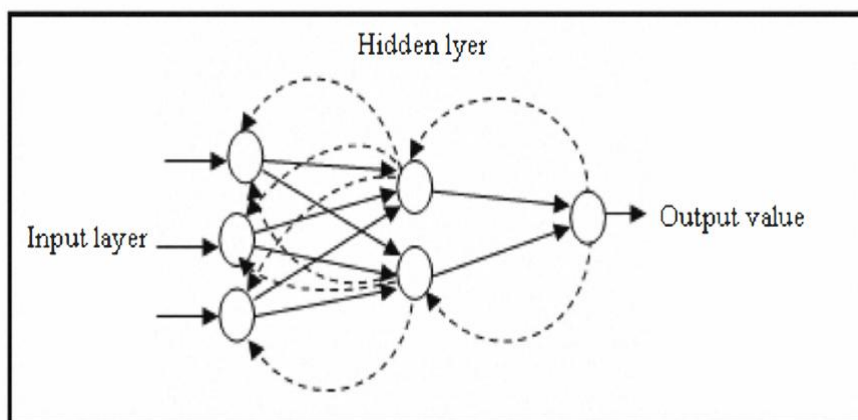

Fig. 1. Structure of a back propagation neural network [16].

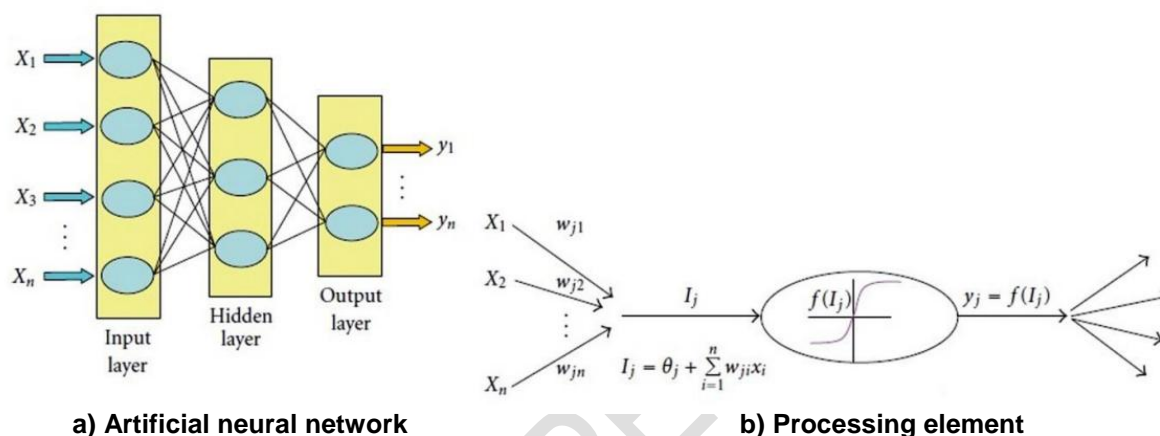

Fig. 2. Structural operation of artificial neural networks [12]

ANNs are organised into layers: an input layer and an output layer, with one or more hidden layers, as indicated in Figure 2. Each processing element's input layer (X_i) is multiplied by an adjustable link weight (W_{ji}). Each processing element adds a threshold value θ_j to $W_{ji}X_i$. The input I_j is passed through an indiscriminate transfer function $f(\cdot)$ to produce the output of the processing elements Y_j . The output of a single processing element is fed into the next layer.

2.2. Why ANN advantageous over other crop models

“Yield prediction is critical for effective crop management and fruit marketing tactics. A variety of methodologies, including statistical tools, crop models, and algorithms, have been created and used to predict yield in agriculture. Correlation and multiple regression analysis are the most commonly used techniques for predicting yield and identifying critical variables influencing agricultural yield” [17, 18, 19, 20]. Machine learning technologies, such as artificial neural networks (ANNs), are emerging as an alternative to traditional linear models for capturing nonlinearity and complex interactions between variables. ANN is a nonlinear data-driven strategy that employs self-adaptive learning techniques [21].

ANNs identify relationships by analysing a large number of input and output cases, resulting in a formula for prediction. Model creation using ANN requires no prior knowledge of the inputs or results. ANN is also superior to any

other linear model since it is capable of selecting the ideal pattern of variables and has lower inaccuracy [22]. Because of these advantages, ANN is widely used in a range of sectors, including hydrology and agriculture [23,24,25,26,27,28].

2.3. Applications of ANN in soil science research

With respect to soil science, ANN generated models can be used to categorize soils, assisting with planning land use, managing soils, monitoring the environment, irrigation management, water resource planning, and estimation of soil moisture content. It can produce real-time predictions of soil moisture levels by taking into account inputs including precipitation, temperature, vegetation indices, and soil parameters. This makes it possible for farmers and managers of water resources to optimize irrigation methods, save water, and increase the effectiveness of water use in agriculture. Arel [29] employed an artificial neural network model to figure out the complex soil of Adapazari (Turkey) based on cone penetration test data. Farrokhzad et al. [30] suggested an ANN model for predicting landslide risk. Ellis et al. [31] developed an artificial neural network (ANN) for sand and grain size distribution and stress history. Turk et al. [32] employed artificial neural networks to describe soil behaviour under uniaxial strain situations.

2.3.1. Predicting engineering properties of soil

Soil engineering qualities that are useful for engineering applications include permeability, compressibility, and shear strength. Engineering qualities of soils quantify their engineering behaviour. Soil engineering properties (soil behaviour following load application) are determined by soil classification, Atterberg's limits, and water content (index properties). So determining those engineering features of soil in the laboratory is a time-consuming, tedious, expensive, and complex operation. [14] Predicting soil engineering properties, viz. maximum dry density (MDD), optimum moisture content (OMC), permeability, unconfined compressive strength (UCS), and shear strength parameters is a difficult task. These engineering properties depend on water content, dry density, and bulk density, mineralogy present in the soil, liquid limit, plastic limit, plasticity index, linear shrinkage, grain size distribution, particle shape, and lots of other parameters. ANN algorithm is favorably used for predicting the engineering properties of soil depend on the input parameters [33].

2.3.1.1. Compaction parameters

Soil compaction is the mechanical process by which soil particles get pushed and compressed. The soil's compaction characteristics (optimal moisture content—OMC and maximum dry density—MDD) are critical for achieving engineering features such as bearing capacity, strength, permeability, and compressibility. ANN is widely used to forecast soil compaction characteristics based on various index properties [14]. Gunaydin [34] estimated the compaction parameters using simple multiple analysis and an artificial neural network, using input parameters including relative density (G), liquid limit (w_L), plastic limit (w_P), and particle size.

Shahiri and Ghasemi [35] conducted laboratory tests to determine MDD and UCS using cement and copper slag stabilised soil. They explore the effects of copper slag and cement at varying percentages on MDD and UCS. Experimentation yielded an ANN model with eight input parameters: dry density, water content, liquid limit, plastic limit, pH, copper slag content, cement content, and curing age. The sensitivity analysis revealed that water content was the most influential parameter, whereas liquid limit and plastic limit were less important. They determined that the ANN model was ready to predict the elastic modulus of stabilised soil.

ANN was applied to estimate maximum dry density (MDD) and unconfined compressive strength (UCS) of stabilized soil where ANN was a more accurate prediction method [36, 37]. As inputs, soil plasticity (LL, PI), clay content (C), sand content (S), gravel content (G), moisture content (MC), and cement content (CC) were utilized to estimate the MDD and UCS of cement stabilized soil [38, 39].

2.3.1.2. Permeability

A soil's ability to allow water to travel through it is referred to as permeability. Given that groundwater conditions are regularly encountered during construction projects, permeability is a crucial soil engineering attribute that the designer must be aware [40]. Permeability is measured in the lab for various soil types using a constant head and falling head permeability test. Permeability can be predicted using artificial neural networks (ANN) using soil index parameters.

[14]. ANN is used as a tool to predict the soil permeability coefficient 'k' allowing the reduction of the costs and time needed to conduct laboratory or field tests to determine this parameter. They presented a method that can be extended to more types of non-cohesive and cohesive soils [41]. Erzin et al. [42] created ANN and MRA (Multiple Regression Analysis) models to estimate the hydraulic conductivity of fine-grained soil. ANN models outperform MRA for determining the hydraulic conductivity of various soils.

2.3.1.3. Shear Strength Parameters

The shear strength of the soil determines its capacity to support a slope in equilibrium, assist in the stacking of a structure, or support its overburden [43]. Shear strength criteria are utilized for foundation design, slope stability, earth and rock fill dam design, earth pressure issues, and highway and airfield design [44]. Shear strength of soil (expressed in terms of cohesion and friction angle) is significant in designing of civil engineering structures and for solving many geotechnical problems. The compaction characteristics, permeability, and soil shear strength were related to soil index properties [33]. The potential of ANN and regression tree technique has been used for the indirect estimation of shear strength parameters [45].

2.3.2. Predicting the geotechnical aspects of expansive soil

Artificial neural networks are used to forecast the complexity of the soil and more efficient. Geotechnical engineering can be used to predict a number of expansive soil parameters, including free swell index, unconfined compressive strength, soil shear strength, swelling pressure, swell percent, and plasticity index.

2.3.2.1. Free Swell Index

Expansive soils can cause issues globally due to their distinctive seasonal nature. Expansive soils destroy all man-made structures, regardless of the materials utilised in the construction process. Traditional laboratory studies are time-consuming and inefficient, thus artificial neural networks are being used to address these challenges [1]. Plasticity index and shrinkage index were given as input factors, with free swell index as the output factor. Back propagation and multiple regression models were used to investigate the ANN model. The free swell index of the soil was precisely estimated using the suggested neural network architecture [46].

2.3.2.2. Unconfined Compressive Strength

Soil stabilisation with cement and lime is an effective means for modifying the ground. Extensive and time-consuming experimental research must be conducted to assess the impact of various cementitious materials on soil behaviour. To estimate soil stiffness and strength, intelligence-based techniques such artificial neural networks (ANNs) and support vector machines (SVMs) are used [47, 48, 49].

By using artificial neural networks and regression analysis [50], prediction of unconfined compressive strength (UCS) of a treated expansive clay soil was done. The soil sample's curing time, the doses of bottom ash and eco sand used as stabilizers, the liquid limit (LL), the plasticity index (IP), and the free swell index are a few of the variables for creating ANN model. Prediction using ANN tool highlighted an enhanced fit than one going for regression analysis between UCS and its relative parameters.

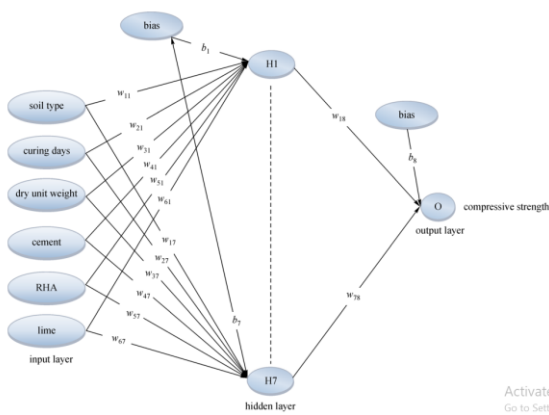

a. ANN model – 1

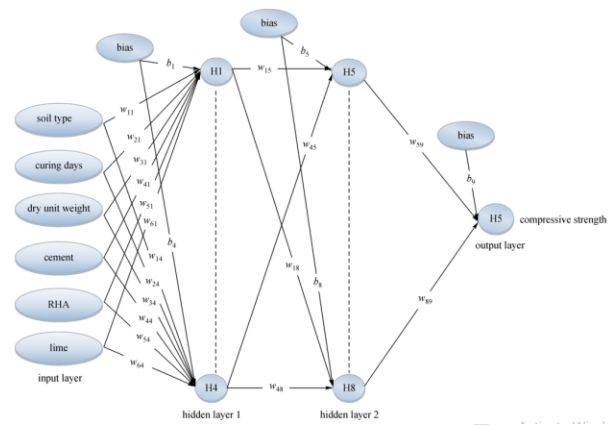

b. ANN model – 2

Fig. 3. Developed ANN models for Unconfined Compressive Strength estimation [51]

Tabarsa et al. [51] used additives to improve soil unconfined compressive strength and used two AI-based models to predict the strength behaviour of stabilised soils wherein ANN models based on feed forward multilayer perceptron neural networks [52] were adopted. The ANN and SVM models outperformed multiple regression analysis in predicting UCS values. The presence of cement and lime had a greater impact on soil UCS values than other parameters studied.

2.3.2.3. Swelling Pressure and Swell Percent

Artificial neural networks are used to estimate the swelling pressures of expansive soils. Merouane et al. [53] used ANN to investigate swelling factors in two different clayey soils from Algeria. Erzin and Gunes [42] proposed a work on the prediction technique using neural networks to understand swell percent and swell pressure of expansive soil. A model with two different transmitted pressures, such as horizontal swelling pressure and perpendicular swelling pressure, was created using the ANN technique. These pressures were used to train an artificial neural network (ANN) to predict transferred lateral and vertical swelling pressure [54].

2.4. Estimation of soil properties by using ANN

ANN has the capacity to manage intricate connections between soil qualities and environmental conditions. ANN models were effective at predicting soil characteristics like pH, organic carbon concentration, and clay content [55]. A number of researchers have employed artificial neural networks (ANN) as a prediction approach for soil properties based on various inputs [56,57,58,59]. The outcomes demonstrated that ANN models performed better than regression models in terms of precision and accuracy. ANN models are useful for forecasting soil characteristics and can offer insightful information for soil management and land-use planning [60]. The benefit of ANNs in managing complicated, non-linear interactions and capturing spatial variability was emphasized [61]. ANN models have shown promise in predicting soil parameters like soil moisture content and soil texture [62].

2.4.1. Estimation of soil physical properties

2.4.1.1. To estimate soil temperature

Soil temperature is a critical meteorological parameter that influences the rates of physical, chemical, and biological reactions in the soil. Ground temperature can fluctuate significantly depending on land cover type and environmental circumstances. Proper prediction of soil temperature is thus required for reliable simulation of land surface processes [63,64,65,66]. Artificial Neural Network (ANN) is used to perform mathematical formulation to learn patterns and relationships in soil temperature observation data [67]. ANN has the ability to recognize complex online correlations between environmental variables and soil temperature [68].

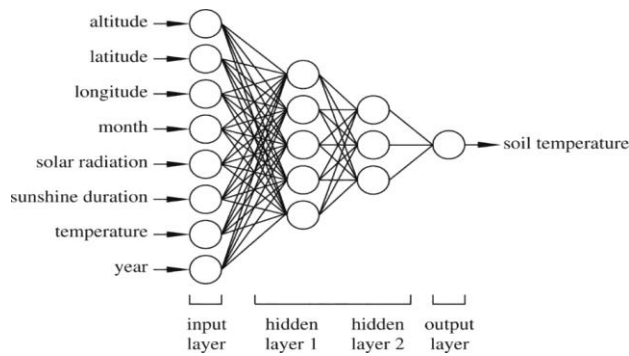

Fig.4 ANN model used for estimating monthly mean soil temperature at various depth [68]

In terms of predicting soil temperature, ANN models performed better than traditional regression models and showed positive outcomes [69]. ANN models performed better than Support Vector Machine models in terms of accuracy and had fewer errors. Due to their accuracy in estimating soil temperature, ANN models can be useful in agricultural and environmental studies [70]. ANN models can successfully be used to estimate soil temperature with high accuracy, especially when trained on big datasets [71] [72]. Biazar et al. [73] observed that in Florida's subtropical grazing lands, the integrated artificial neural network and Sperm Swarm Optimization (SSO) models (MLP-SSO) were more accurate tools for soil temperature forecasting than the original artificial neural network approaches among various soil depths.

2.4.1.2. To estimate soil water retention

The soil water retention curve (WRC) describes a soil's ability to store water at various suctions. WRC of a soil is determined by its texture, structure [74] porosity and grain size distribution [75]. Many investigations of water flow and solute transport in the vadose zone involve estimations of unsaturated soil hydraulic parameters, such as the soil water retention curve (WRC), which describes the connection between soil suction and water content. When compared to many analytical retention functions often employed in the vadose zone hydrology literature, the ANN technique produced equivalent or more accurate descriptions of the retention data. Given enough input data, the ANN technique was found to accurately characterise a soil's hysteretic behaviour, including observed scanning wetting and drying curves. The WRC of a soil was modeled by ANNs using the measured data of soil moisture content and suction [74]. When estimating soil water retention, ANN models are frequently more accurate than traditional regression models [76]. When examining the performance of ANN and multiple linear regression (MLR) models to estimate soil water retention, ANN models excelled MLR models, in terms of accuracy and precision. The ANN models were able to capture the nonlinear nature of the relationships between soil properties and water retention, which improved predictions [77, 78].

2.4.2.5. To predict soil hydraulic conductivity and soil infiltration rate

Saturated hydraulic conductivity (K_{sat}), a critical soil hydraulic property, is used to simulate a variety of soil hydrological processes. Routine K_{sat} measurement is a labor-intensive, time-consuming, and expensive technique. Alternatively, predicting K_{sat} values from readily available soil properties is more cost-effective and time-saving. Artificial neural networks (ANNs) can be used to model and describe the most important features that influence K_{sat} [79]. ANNs are effective at capturing intricate connections between soil properties and hydraulic conductivity [80]. ANN models outperform conventional regression models and can offer precise estimates of hydraulic conductivity. ANN models outperformed pedo-transfer functions (PTFs) in terms of accuracy and had fewer errors [81] and can be useful for hydrological modeling and can be good in estimating soil hydraulic conductivity.

Infiltration rate is a critical component of the hydrological cycle. Along with precipitation, soil infiltration rate affects plant water availability, runoff, and reservoir and groundwater supply [16]. Data to estimate soil parameters using readily available data, such as textural soil qualities (i.e., particle-size distribution and porosity) are represented by the Pedotransfer functions (PTFs) method, which can be applied at the local scale with point textural qualities or at the watershed scale with aggregated textural information [82]. The critical stage in deriving PTFs is to establish empirical correlations between basic soil qualities and the parameters to be predicted. This can be accomplished by a variety of statistical methods, including multivariable linear regression [83]. Artificial neural networks (ANN) are a recent way to

fitting PTFs [84]. ANN model is a more realistic and reliable since it does not predict negative steady infiltration rate values [16].

2.4.2. Estimation of soil chemical properties

2.4.2.1. To measure soil electrical conductivity

Sensors used in precision agriculture, namely those measuring apparent electrical conductivity (ECa), have a strong correlation with other soil properties [85]. ECa is a minimally invasive characteristic that can describe the spatial distribution of soil qualities for agricultural management [85, 86]. Uribeetxebarria et al. [87] used ECa and multivariate analysis of variance to analyse soil composition and variability in fruit growing areas. Sanches et al. [88] described soil pH and developed models for lime recommendation based on geographical analysis, with ECa as the predictor variable. Bottega et al. [89] defined soybean culture management zones based on ECa as an input variable, whether or not it was connected with soil texture. In the study of Pentoś et al., [15], a correlation between soil electrical characteristics (apparent soil electrical conductivity (ECa) and magnetic susceptibility (MS) measured at two depths (0.5 and 1 m) and soil compaction was examined using artificial neural networks.

2.4.2.2. To measure soil organic carbon

The accurate prediction of wetland soil organic carbon content (SOCc) and an understanding of its controlling factors are critical for investigating regional climate change and wetland carbon cycles [90]. The accuracy of wetland SOCc prediction is mostly limited by forecast methodologies and input data availability [91]. Several machine learning algorithms, such as support vector regression (SVR) [92], boosted regression tree [93], random forest (RF) [94], and artificial neural networks (ANNs) [95,96], were used to predict soil properties at different scales. ANNs are a highly effective tool for identifying nonlinear correlations between soil characteristics and environmental variables [97, 98]. The geographical and vertical distributions of wetland SOCc in China's Liao River Basin (LRB) were investigated using a combination method that included ANN and ordinary kriging (OK). ANN-OK proved successful in predicting wetland SOCc on a regional scale [99, 100]

2.7.1. FACTORS IN ANN

2.7.1.1. ANN in environmental factors

The yield at the end of the growing season is strongly influenced by the environment for agricultural plants. The most crucial environmental elements that affect plant development, growth, and production include temperature, photoperiod, and water stress [101]. In order to forecast leaf moisture, created a generalized regression neural network (GRNN), which was compared to multiple linear regression (MLR). Based on temperature, relative humidity, wind speed, solar radiation, and prediction, leaf wetness is forecast in order to forewarn of disease in agricultural crops that would sooner or later damage crop yield production [102]. Hossain et al. [103] developed a Weather-based Prediction System for Rice Yield for the prognostication of rice yield in distinct territories of Bangladesh.

2.7.1.2. ANN in soil and soil-plant hydrology

In order to evaluate the nonlinear relationship between soil characteristics and crop yield used a feed forward neural network. The estimated yield maps produced by the neural network method tended to be fairly close to the real yield map, despite the fact that the model tended to overestimate low yielding sites while underestimating the higher yielding ones [104]. Liu et al. [105] employed a neural network with one hidden layer to predict corn yield using input data on soil, weather, and management.

2.7.1.3. ANN in sensing technologies.

For site-specific management in agriculture, sensing technologies have grown in significance. Many different types of sensors and instruments, including field-based electronic sensors, spectro radiometers, machine vision, air borne multispectral and satellite imagery, thermal imaging, etc., have been used in the development of sensing systems for various applications, including yield mapping and prediction, irrigation control, etc. These technologies have a

wide range of applications in monitoring a wide range of variables, including crop nutrients, water content, and soil characteristics [106]. Russello [107] used convolutional neural networks for crop yield prediction based on satellite images. Their model used 3-dimensional convolution to include spatiotemporal features, and outperformed other machine learning methods.

2.7.1.4. ANN in controlled environment

When speaking of the greenhouse climate, reference is made to the environmental conditions that the plants require to be in good condition [108]. The greenhouse microclimate is complex, multiparametric, non-linear and depends on a set of external and internal factors. External factors include meteorological factors such as ambient temperature and humidity, the intensity of solar radiation, wind direction, and speed among others. Internal factors are crops, greenhouse dimensions, greenhouse components and elements such as heating, fogging and ventilation systems, soil types, etc. [109]. In controlled environments like green houses and glass houses, ANN models have also been used. In a green house, environmental elements include temperature, humidity, radiation intensity, and carbon-dioxide concentration a real ways taken into consideration in order to optimize plant development and production [110]. The ANN was more accurate in 81% of the cases than the classic method in forecasting the internal relative humidity and 62% more efficient in forecasting the internal temperature [111, 112].

3. CONCLUSION

Artificial neural network (ANN) use in soil science research has considerable promise for overcoming major obstacles and improving our comprehension of phenomena relating to soil. ANN has the potential to revolutionize soil management techniques, increase agricultural output, and encourage sustainable land use due to their capacity to model complicated soil processes, anticipate soil attributes, and support decision-making processes. Researchers can gain new insights into soil science and help to improve soil conservation and environmental stewardship by further investigating and improving ANN techniques. The continued use of ANNs in soil science research will open the door to a greater comprehension of the soil environment and the creation of methods for sustainable soil management.

REFERENCES

1. Goutham DR, Krishnaiah AJ. Application of Artificial Neural Networking Technique to Predict the Geotechnical Aspects of Expansive Soil: A Review. *International Journal Engineering and Manufacturing*. 2021; 11(6):48-53. DOI:10.5815/ijem.2021.06.0
2. Siti Khairunniza-Bejo, Samihah Mustaffha, Wan Ishak Wan Ismail. Application of Artificial Neural Network in Predicting Crop Yield: A Review", *Journal of Food Science and Engineering*. 2014; 4:1-9.
3. Kujawa S, Niedbała G. Artificial neural networks in agriculture. *Agriculture*. 2021;11(6):497.
4. Lai J, Qiu J, Feng Z, Chen J, Fan H. Prediction of soil deformation in tunnelling using artificial neural networks. *Computational Intelligence and Neuroscience*. 2016;2016:33. <http://dx.doi.org/10.1155/2016/6708183>
5. Jain AK, Mao J, Mohiuddin KM. Artificial neural networks: A tutorial. *Computer*. 1996;29(3):31-44.
6. Boniecki P, Koszela K, Świerczyński K, Skwarcz J, Zaborowicz M, Przybył J. Neural visual detection of grain weevil (*Sitophilus granarius* L.). *Agriculture*. 2020;10(1):25.
7. Niedbała G, Kurasiak-Popowska D, Stuper-Szablewska K, Nawracała J. Application of artificial neural networks to analyze the concentration of ferulic acid, deoxynivalenol, and nivalenol in winter wheat grain. *Agriculture*. 2020;10(4):127.
8. Li Y, Chao X. ANN-based continual classification in agriculture. *Agriculture*. 2020;10(5):178.
9. Aji GK, Hatou K, Morimoto T. Modeling the dynamic response of plant growth to root zone temperature in hydroponic chili pepper plant using neural networks. *Agriculture*. 2020;10(6):234.

10. García-Martínez H, Flores-Magdaleno H, Ascencio-Hernández R, Khalil-Gardezi A, Tijerina-Chávez L, Mancilla-Villa OR, Vázquez-Peña MA. Corn grain yield estimation from vegetation indices, canopy cover, plant density, and a neural network using multispectral and RGB images acquired with unmanned aerial vehicles. *Agriculture*. 2020;10(7):277.
11. Dahikar SS and Rode SV. Agricultural Crop Yield Prediction Using Artificial Neural Network Approach. *International journal of innovative research in electrical, electronics, instrumentation and control engineering*. 2014;2(1).
12. Shahin MA. State-of-the-art review of some artificial intelligence applications in pile foundations. *Geoscience Frontiers*. 2016;7(1):33-44.
13. Sarmadian F, Taghizadeh Mehrjardi R. Modeling of some soil properties using artificial neural network and multivariate regression in Gorgan Province, North of Iran. *Global Journal of Environmental Research*. 2008;2(1):30-5.
14. Dhawale AW, Banne SP. Comparative Study of Application of Artificial Neural Networks for Predicting Engineering Properties of Soil: A Review. In *Proceedings of Fourth International Conference on Inventive Material Science Applications*. ICIMA. 2021:751-763.
15. Pentoś K, Pieczarka K, Serwata K. The relationship between soil electrical parameters and compaction of sandy clay loam soil. *Agriculture*. 2021;11(2):114.
16. Ekhmaj AI. Predicting soil infiltration rate using artificial neural network. In *2010 International Conference on Environmental Engineering and Applications*. 2010; 117-121. IEEE.
17. Gutiérrez PA, López-Granados F, Peña-Barragán JM, Jurado-Expósito M, Hervás-Martínez C. Logistic regression product-unit neural networks for mapping *Ridolfia segetum* infestations in sunflower crop using multitemporal remote sensed data. *Computers and Electronics in Agriculture*. 2008;64(2):293-306.
18. Huang Y, Lan Y, Thomson SJ, Fang A, Hoffmann WC, Lacey RE. Development of soft computing and applications in agricultural and biological engineering. *Computers and electronics in agriculture*. 2010;71(2):107-27.
19. Kravchenko AN, Bullock DG. Correlation of corn and soybean grain yield with topography and soil properties. *Agronomy journal*. 2000;92(1):75-83.
20. Park SJ, Hwang CS, Vlek PL. Comparison of adaptive techniques to predict crop yield response under varying soil and land management conditions. *Agricultural Systems*. 2005;85(1):59-81.
21. Das P. Study on Machine Learning Techniques Based Hybrid Model for Forecasting in Agriculture. Ph.D. Thesis, PG-school IARI, New Delhi, India, 2019.
22. Abdipour M, Younessi-Hmazekhanlu M, Ramazani SH. Artificial neural networks and multiple linear regression as potential methods for modeling seed yield of safflower (*Carthamus tinctorius* L.). *Industrial crops and products*. 2019;127:185-94.
23. Guimarães BVC, Donato SLR, Aspiazú I, Azevedo AM. Yield prediction of 'Prata Anã' and 'BRS Platina' banana plants by artificial neural. *Pesq. Agropec. Trop. Goiânia* 2021; 51: 1–11.
24. Schultz A, Wieland R, Lutze G. Neural networks in agroecological modeling-stylish application or helpful tool? *Comput. Electron. Agric.* 2000; 29: 73–97.
25. Fortin JG, Anctil F, Parent LÉ, Bolinder MA. A neural network experiment on the site-specific simulation of potato tuber growth in Eastern Canada. *Comput. Electron. Agric.* 2010; 73: 126–132.
26. Mansouri A, Fadavi A, Mortazavian SMM. An artificial intelligence approach for modeling volume and fresh weight of callus—A case study of cumin (*Cuminum cyminum* L.). *J. Theor. Biol.* 2016; 397: 199–205.
27. Treder W. Relationship between yield, crop density coefficient and average fruit weight of 'gala' apple. *J. Fruit Ornament. Plant Res.* 2008; 16: 53–63.
28. Gholipoor M, Rohani A, Torani S. Optimization of traits to increasing barley grain yield using an artificial neural network. *Int. J. Plant Prod.* 2013; 7: 1–17.

29. Arel E. Predicting the spatial distribution of soil profile in Adapazari/Turkey by artificial neural networks using CPT data. *Computers & Geosciences*. 2012;43:90-100.
30. Farrokhzad F, Choobbasti AJ, Barari A. Liquefaction microzonation of Babol city using artificial neural network. *Journal of King Saud University-Science*. 2012;24(1):89-100.
31. Ellis GW, Yao C, Zhao R, Penumadu D. Stress-strain modeling of sands using artificial neural networks. *Journal of geotechnical engineering*. 1995;121(5):429-35.
32. Turk G, Logar J, Majes B. Modelling soil behaviour in uniaxial strain conditions by neural networks. *Advances in engineering software*. 2001;32(10-11):805-12.
33. Tizpa P, Chenari RJ, Fard MK, Machado SL. ANN prediction of some geotechnical properties of soil from their index parameters. *Arab J Geosci*. 2015; 8:2911–2920.
34. Günaydin OJ. Estimation of soil compaction parameters by using statistical analyses and artificial neural networks. *Environmental Geology*. 2009;57:203-15.
35. Shahiri J, Ghasemi M. Utilization of soil stabilization with cement and copper slag as subgrade materials in road embankment construction. *International Journal of Transportation Engineering*. 2017;5(1):45-58.
36. Alavi AH, Gandomi AH, Mollahassani A, Heshmati AA, Rashed A. Modeling of maximum dry density and optimum moisture content of stabilized soil using artificial neural networks. *J Plant Nutr Soil Sci*. 2010; 173(3):368–379.
37. Das SK, Samui P, Sabat AK. Application of artificial intelligence to maximum dry density and unconfined compressive strength of cement stabilized soil. *Geotechnical and Geological Engineering*. 2011; 29:329-342.
38. Das SK, Suman S. Prediction of lateral load capacity of pile in clay using multivariate adaptive regression spline and functional network. *Arab J Sci Eng*. 2015; 40(6):1565–1578. DOI:10.1007/s13369-015-1624-y.
39. Suman S, Mahamaya M, Das SK. Prediction of maximum dry density and unconfined compressive strength of cement stabilized soil using artificial intelligence techniques. *International Journal of Geosynthetics and Ground Engineering*, 2016; 2:1-11.
40. Sinha SK, Wang MC. Artificial neural network prediction models for soil compaction and permeability. *Geotechnical and Geological Engineering*. 2008; 26:47-64.
41. Grzegorz Wrzesiński, Markiewicz A. Prediction of Permeability Coefficient k in Sandy Soils Using ANN. *Sustainability*. 2022; 14(11):6736. <https://doi.org/10.3390/su14116736>
42. Erzin Y, Gumaste SD, Gupta AK, Singh DN. Artificial neural network (ANN) models for determining hydraulic conductivity of compacted fine-grained soils. *Canadian Geotechnical Journal*. 2009;46(8):955-68.
43. Armaghani DJ, Mirzaei F, Shariati M, Trung NT, Shariati M, Trnavac D. Hybrid ANN-based techniques in predicting cohesion of sandy-soil combined with fiber. *Geomech.Eng.*2020;20(3):191-205.
44. Mousavi SM, Alavi AH, Gandomi AH, Mollahasani A. Nonlinear genetic-based simulation of soil shear strength parameters. *Journal of earth system science*. 2011; 120: 1001-1022.
45. Kanung D, Sharma S, Pain A. Artificial Neural Network (ANN) and Regression Tree (CART) applications for the indirect estimation of unsaturated soil shear strength parameters. *Frontiers of earth science*, 2014. 8(3): p. 439-456.
46. Dutta RK, Singh A, Gnananandarao T. Prediction of free swell index for the expansive soil using artificial neural networks. *Journal of Soft Computing in Civil Engineering*. 2019; 3(1):47-62.
47. Shahin M A, Maier H R, Jaksa M B. Data division for developing neural networks applied to geotechnical engineering. *Journal of Computing in Civil Engineering*. 2004; 18(2): 105–114
48. Narendra B S, Sivapullaiah P V, Suresh S, Omkar S N. Prediction of unconfined compressive strength of soft grounds using computational intelligence techniques: A comparative study. *Computers and Geotechnics*. 2006; 33(3): 196–208

49. Kalkan E, Akbulut S, Tortum A, Celik A. Prediction of the unconfined compressive strength of compacted granular soils by using inference systems. *Environmental Geology* (Berlin). 2009; 58(7): 1429–1440
50. Sathyapriya S, Arumairaj P, Ranjini D. Prediction of unconfined compressive strength of a stabilized expansive clay soil using ANN and regression analysis (SPSS). *Asian Journal of Research in Social Sciences and Humanities*. 2017; 7(2): 109-123.
51. Tabarsa A, Latifi N, Osouli A, Bagheri Y. Unconfined compressive strength prediction of soils stabilized using artificial neural networks and support vector machines. *Frontiers of Structural and Civil Engineering*. 2021;15(2):520-36.
52. Wang O, Al-Tabbaa A. Preliminary model development for predicting strength and stiffness of cement-stabilized soils using artificial neural networks. In: *ASCE International Workshop on Computing in Civil Engineering*. Los Angeles, CA, 2013; 299–306.
53. Merouane FZ, Mamoune SM. Prediction of swelling parameters of two clayey soils from Algeria using artificial neural networks. *Modelling in Civil Environmental Engineering*. 2018 ;14(3):11-26.
54. Ikizler SB, Aytakin M, Vekli M, Kocabaş F. Prediction of swelling pressures of expansive soils using artificial neural networks. *Advances in Engineering Software*, 2010; 41(4):647-655.
55. Minasny B, Mc Bratney AB. A Conditioned Latin Hypercube Method for Sampling in the Presence of Ancillary Information. *Computers & Geosciences*. 2006; 32: 1378-1388. <https://doi.org/10.1016/j.cageo.2005.12.009>.
56. Daniel KW, Tripathi NK, Honda K. Artificial neural network analysis of laboratory and in situ spectra for the estimation of macronutrients in soils of Lop Buri (Thailand). *Aust J Soil Res*. 2003; 41 (1): 47-59. <https://doi.org/10.1071/SR02027>
57. Guo PT, Wu W, Sheng QK, Li MF, Lui HB, Wang ZY. Prediction of soil organic matter using artificial neural network and topographic indicators in hilly áreas. *Nutr Cyc Agro*. 2013; 95 (3): 333-344. <https://doi.org/10.1007/s10705-013-9566-9>
58. Kolassa J, Reichle RH, Liu Q, Alemohammad SH, Gentine P, Aida K. Estimating surface soil moisture from SMAP observations using a neural network technique. *Rem Sens Environ*. 2018; 204: 43-59. <https://doi.org/10.1016/j.rse.2017.10.045>
59. Ng W, Minasny B, Montazerolghaem M, Padarian J, Ferguson R, Bailey S. Convolutional neural network for simultaneous prediction of several soil properties using visible/near-infrared, mid-infrared, and their combined spectra. *Geoderma*. 2019; 352: 251-267. <https://doi.org/10.1016/j.geoderma.2019.06.016>
60. Heung B, Ho HC, Zhang J, Knudby A, Bulmer CE, Schmidt MG. An overview and comparison of machine learning techniques for classification purposes in digital soil mapping. *Geoderma*. 2016; 265:62-77.
61. Wadoux AMC, Padarian J, Minasny B. Multi-source data integration for soil mapping using deep learning. *Soil*. 2019; 5(1):107-119.
62. Padarian J, Minasny B, Mc Bratney AB. Using deep learning to predict soil properties from regional spectral data. *Geoderma*. 2018; 15: e00198.
63. Hillel D. *Environmental Soil Physics* Academic Press. San Diego, CA. 1998.
64. Pessarakli M, Szabolcs I. Soil salinity and sodicity as particular plant/crop stress factors. In Pessarakli M. (Ed.) *Handbook of Plant and Crop Stress*. 2002.
65. Yildirim AN, Şan B, Yildirim F, Celik C, Bayar B, Karakurt Y. Physiological and biochemical responses of almond rootstocks to drought stress. *Turkish Journal of Agriculture and Forestry*. 2021;45(4):522-32.
66. Biazar SM, Ferdosi FB. An investigation on spatial and temporal trends in frost indices in Northern Iran. *Theoretical and Applied Climatology*. 2020;141(3):907-20.
67. Jebamalar S, Christopher JJ, Ajisha MA. Random input based prediction and transfer of heat in soil temperature using artificial neural network. *Materials Today: Proceedings*. 2021;45:1540-6.
68. Ozturk M, Salman O, Koc M. Artificial neural network model for estimating the soil temperature. *Canadian journal of soil science*. 2011;91(4):551-62. <https://doi.org/10.4141/cjss10073>.

69. Mirzaei-Paiaman, Salavati S. The Application of Artificial Neural Networks for the Prediction of Oil Production Flow Rate, Energy Sources, Part A: Recovery, Utilization, and Environmental Effects. 2012; 34:19:1834-1843, DOI: 10.1080/15567036..492386
70. Trumbore SE, Chadwick OA, Amundson R. Rapid exchange between soil carbon and atmospheric carbon dioxide driven by temperature change. *Science*, 1996; 272(5260):393-396.
71. Morteza Amiri, Javad Ghiasi-Freez, Behnam Golkar, Amir Hatampour. Improving water saturation estimation in a tight shaly sandstone reservoir using artificial neural network optimized by imperialist competitive algorithm – A case study. *Journal of Petroleum Science and Engineering*, 2015;127 :347-358.
72. Tenge AJ, Kaihura FBS, Lal R, Singh BR. Diurnal soil temperature fluctuations for different erosion classes of an oxisol at Mlingano, Tanzania. *Soil and Tillage Research*. 1998; 49(3):211-217.
73. Biazar SM, Shehadeh HA, Ghorbani MA, Golmohammadi G, Saha A. Soil temperature forecasting using a hybrid artificial neural network in Florida subtropical Grazinglands agro-ecosystems. *Scientific Reports*. 2024;14(1):1535.
74. Jain SK, Singh VP. Modeling soil water retention curve using ANN. Theme D: Hydraulic Parameter Estimation - Remote Sensing. 2003.
75. Jain SK, Singh VP, Van Genuchten MT. Analysis of soil water retention data using artificial neural networks. *Journal of Hydrologic Engineering*. 2004;9(5):415-20.
76. Bharti B, Pandey A, Tripathi SK, Kumar D. Modeling of runoff and sediment yield using ANN, LS-SVR, REP Tree and M5 models. *Hydrology Research*. 2017; 48(6):1489-1507.
77. Chatterjee S, Mahapatra SS, Bharadwaj V, Choubey A, Upadhyay BN, Bindra KS. Drilling of micro-holes on titanium alloy using pulsed Nd:YA Glaser: parametric appraisal and prediction of performance characteristics. *Proceedings of the Institution of Mechanical Engineers, Part B:Journal of Engineering Manufacture*. 2019; 233(8): 1872-1889.
78. Mirzaei-Paiaman, Salavati S. The Application of Artificial Neural Networks for the Prediction of Oil Production Flow Rate, Energy Sources, Part A: Recovery, Utilization, and Environmental Effects. 2012; 34:19:1834-1843, DOI: 10.1080/15567036..492386
79. Albalasmeh A, Mohawesh O, Gharaibeh M, Deb S, Slaughter L, El Hanandeh A. Artificial neural network optimization to predict saturated hydraulic conductivity in arid and semi-arid regions. *Catena*. 2022;217:106459.
80. Wösten JHM, Pachepsky YA, Rawls WJ. Pedotransfer functions: bridging the gap between available basic soil data and missing soil hydraulic characteristics. *Journal of hydrology*. 2001; 251(3-4):123-150.
81. Bahrami B, Dianati Tilaki GA, Khosro Beigi S, Janizadeh S, Moetamedi J. Evaluation of artificial neural network (ANN), adaptive neuro fuzzy inference system (ANFIS) and regression models in prediction of particulate organic matter-carbon (POM-C) in the range lands Kharabe Sanji of Urmia. *Applied Soil Research*. 2013; 1(1): 94-106.
82. Delleur JW, editor. *The handbook of groundwater engineering*. CRC press; 2006.
83. Wösten JH, Finke PA, Jansen MJ. Comparison of class and continuous pedotransfer functions to generate soil hydraulic characteristics. *Geoderma*. 1995;66(3-4):227-37.
84. Schaap MG, Leij FJ. Using neural networks to predict soil water retention and soil hydraulic conductivity. *Soil and Tillage Research*. 1998;47(1-2):37-42.
85. Grubbs RA, Straw CM, Bowling WJ, Radcliffe DE, Taylor Z, Henry GM. Predicting spatial structure of soil physical and chemical properties of golf course fairways using an apparent electrical conductivity sensor. *Precision agriculture*. 2019;20:496-519.
86. Serrano JM, Shahidian S, Marques da Silva J. Spatial variability and temporal stability of apparent soil electrical conductivity in a Mediterranean pasture. *Precision agriculture*. 2017;18:245-63.
87. Uribeetxebarria A, Arnó J, Escolà A, Martínez-Casasnovas JA. Apparent electrical conductivity and multivariate analysis of soil properties to assess soil constraints in orchards affected by previous parcelling. *Geoderma*. 2018;319:185-93.
88. Sanches GM, Magalhães PS, Remacre AZ, Franco HC. Potential of apparent soil electrical conductivity to describe

- the soil pH and improve lime application in a clayey soil. *Soil and Tillage Research*. 2018;175:217-25.
89. Bottega EL, de Queiroz DM, de Assis de Carvalho Pinto F, de Souza CM, Valente DS. Precision agriculture applied to soybean: Part I-Delineation of management zones. *Australian Journal of Crop Science*. 2017;11(5):573-9.
 90. Stockmann U, Adams MA, Crawford JW, Field DJ, Henakaarchchi N, Jenkins M, Minasny B, McBratney AB, De Courcelles VD, Singh K, Wheeler I. The knowns, known unknowns and unknowns of sequestration of soil organic carbon. *Agriculture, Ecosystems & Environment*. 2013;164:80-99.
 91. Triantafyllis J, Odeh IO, McBratney AB. Five geostatistical models to predict soil salinity from electromagnetic induction data across irrigated cotton. *Soil Science Society of America Journal*. 2001;65(3):869-78.
 92. Ballabio C. Spatial prediction of soil properties in temperate mountain regions using support vector regression. *Geoderma*. 2009;151(3-4):338-50.
 93. Wang B, Waters C, Orgill S, Cowie A, Clark A, Li Liu D, Simpson M, McGowen I, Sides T. Estimating soil organic carbon stocks using different modelling techniques in the semi-arid rangelands of eastern Australia. *Ecological indicators*. 2018 ;88:425-38.
 94. Subburayalu SK, Slater BK. Soil series mapping by knowledge discovery from an Ohio county soil map. *Soil Science Society of America Journal*. 2013;77(4):1254-68.
 95. Li QQ, Yue TX, Wang CQ, Zhang WJ, Yu Y, Li B, Yang J, Bai GC. Spatially distributed modeling of soil organic matter across China: An application of artificial neural network approach. *Catena*. 2013;104:210-8.
 96. Malone BP, McBratney AB, Minasny B, Laslett GM. Mapping continuous depth functions of soil carbon storage and available water capacity. *Geoderma*. 2009;154(1-2):138-52.
 97. Were K, Bui DT, Dick ØB, Singh BR. A comparative assessment of support vector regression, artificial neural networks, and random forests for predicting and mapping soil organic carbon stocks across an Afromontane landscape. *Ecological Indicators*. 2015;52:394-403.
 98. Zhao Z, Yang Q, Benoy G, Chow TL, Xing Z, Rees HW, Meng FR. Using artificial neural network models to produce soil organic carbon content distribution maps across landscapes. *Canadian Journal of Soil Science*. 2010;90(1):75-87.
 99. Zhao Z, Chow TL, Rees HW, Yang Q, Xing Z, Meng FR. Predict soil texture distributions using an artificial neural network model. *Computers and electronics in agriculture*. 2009 ;65(1):36-48.
 100. Kang Y, Li X, Mao D, Wang Z, Liang M. Combining Artificial Neural Network and Ordinary Kriging to Predict Wetland Soil Organic Carbon Concentration in China's Liao River Basin. *Sensors*. 2020;20(24):7005.
 101. Ushada M, Murase H. Identification of a moss growth system using an artificial neural network model. *Biosystems engineering*. 2006; 94(2):179-189.
 102. Chtioui Y, Panigrahi S, Francl L. A generalized regression neural network and its application for leaf wetness prediction to forecast plant disease. *Chemometrics and Intelligent Laboratory Systems*. 1999; 48(1): 47-58.
 103. Hossain MA, Uddin MN, Hossain MA, Jang YM. Predicting rice yield for Bangladesh by exploiting weather conditions. In 2017 international conference on information and communication technology convergence (ICTC) 2017; 589-594. IEEE. <https://doi.org/10.1109/ICTC.2017.8191047>.
 104. Drummond S, Joshi A, Sudduth KA. Application of neural networks: precision farming. In 1998 IEEE International Joint Conference on Neural Networks Proceedings. IEEE World Congress on Computational Intelligence. 1998; 1: 211-215.
 105. Liu J, Goering CE, Tian L. A neural network for setting target corn yields. *Transactions of the ASAE*. 2001;44(3):705.
 106. Lee WS, Alchanatis V, Yang C, Hirafuji M, Moshou D, Li C. Sensing technologies for precision specialty crop production. *Computers and electronics in agriculture*. 2010; 1;74(1):2-33.

107. Russello H. Convolutional neural networks for crop yield prediction using satellite images. IBM Center for Advanced Studies. 2018.
108. Frausto HU, Pieters JG. Modelling greenhouse temperature using system identification by means of neural networks. *Neurocomputing*. 2004;56:423-8.
109. Fitz-Rodríguez E, Kubota C, Giacomelli GA, Tignor ME, Wilson SB, McMahon M. Dynamic modeling and simulation of greenhouse environments under several scenarios: A web-based application. *Computers and electronics in agriculture*. 2010;70(1):105-16.
110. Ushada M, Murase H. Identification of a moss growth system using an artificial neural network model. *Biosystems engineering*. 2006; 94(2):179-189.
111. Bussab MA, Bernardo JI, Hirakawa AR. Greenhouse modeling using neural networks. InProc. of the 6th WSEAS Int. Conf. on Artificial Intelligence, Knowledge Engineering and Data Bases 2007; 131-135.
112. Seginer I, Boulard TH, Bailey BJ. Neural network models of the greenhouse climate. *Journal of Agricultural Engineering Research*. 1994;59(3):203-16.

UNDER PEER REVIEW