

# **A Study on Dimensional Variations in Commercial Cultivator Tines and Reversible Shovels in Comparison to Bureau of Indian Standards Norms**

## **Abstract**

Accelerated demand for farm equipment has encouraged many producers to initiate production of farm machinery. Bureau of Indian Standards (BIS) provide standards for cultivators but commercial agricultural machinery manufacturers design based on trial and error basis without knowing the concept of optimization, which in turn leads to unnecessary design and cost and also affects equipment performance. With respect to this, study was undertaken to check the dimensions of commercially available cultivator tines (Rigid and spring) and reversible shovels. Based on the usability and availability commercially available rigid and spring cultivator tines and also reversible shovels were selected by conducting survey around Udaipur region. The dimensions of selected cultivator tines and reversible shovels were measured by using vernier calliper and measuring tape. The dimensions of selected rigid and spring cultivator tines found almost higher values as compared to BIS recommended value. Also among shovels, shovel 1 (Sh<sub>1</sub>) and shovel 2 (Sh<sub>2</sub>) measured higher values as compared to BIS recommended value, whereas shovel 3 (Sh<sub>3</sub>) found minimum values as compared to BIS recommended value.

**Keywords:** farm machinery, rigid tine, spring tine, reversible shovels, BIS.

## **1. Introduction**

“The agricultural mechanization sector is significantly influenced by farm machinery and the methodology associated with its use” (Oduma *et al.*, 2019). “To increase agricultural productivity against the backdrop of limited resources and climate change, a sustainable agricultural approach is required” (Jyoti *et al.*, 2019). “Farm machinery is a key driver of agricultural productivity. Indian agriculture has seen exponential growth in the mechanization of farms” (Verma and Guru, 2014). “It leads to a timeliness that also increases productivity and income in turn. Farm machines supplied to the farmers must ensure functional and life reliability. For this, testing of machines according to a well-established standardization procedure is important” (Sahay, 1971). “Accelerated demand for farm equipment has encouraged many producers to initiate production of farm machinery. With heavy investment on farm machinery, it is necessary to have some means of assessing the performance of

machines being brought out by the various manufacturers before being used by the farmers” (Anonymous, 2017).

“Cultivator is an implement which is used for both primary and secondary tillage farm operations by the Indian farmers. There are two types of tractor operated cultivator available in India, namely rigid tine cultivator and spring tine cultivators” (Mwitiet *al* 2023). “Also, depending upon the type of soil and crop, the shovels are used as the working tool in the cultivator” (Sahay, 1971). The BIS provide standard dimensions for cultivators but commercial agricultural machinery manufacturers design based on trial and error basis without understanding the concept of optimization, which in turn leads to unnecessary design and cost (Badegaonkar et al., 2010), it also affects equipment performance, leading to excessive operating cost and in turn being a burden on farmers. [9]

Studying and providing the possible information on the dimensions of commercially available implement is very necessary in order to reduce the energy requirement, excessive design and cost and also to improve the performance of the implement. In view of the above, present study was undertaken to check the dimensions of selected commercially available cultivator tines and reversible shovels.

## **2. Material and Methodology**

The survey was conducted around Udaipur region for the selection of commercially available rigid and spring cultivator tines and also reversible shovels to determine the performance under controlled conditions and also to do the comparison with the dimensions of BIS standard cultivator tines and reversible shovels. Based on the use of these for the various farm operations and availability around the region two types of cultivator tines such as rigid tine (CT<sub>1</sub>) and spring tine (CT<sub>2</sub>) were selected (Okokoet *al* 2023). Also based on the type of soil, three different types of commercially available reversible shovels (Sh<sub>1</sub>, Sh<sub>2</sub> and Sh<sub>3</sub>) were selected. The dimensions of selected cultivator tines and reversible shovels were measured by using vernier calliper and measuring tape.



**Rigid tine (CT<sub>1</sub>)**

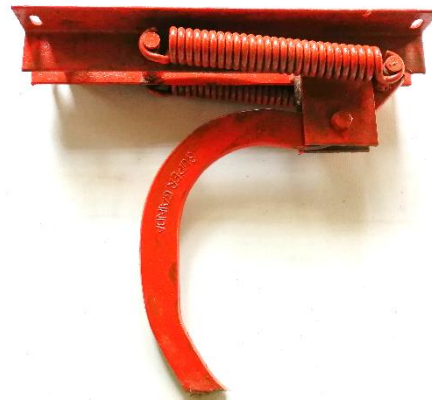

**Spring tine (CT<sub>2</sub>)**



**Shovel (Sh<sub>1</sub>)**



**Shovel (Sh<sub>2</sub>)**

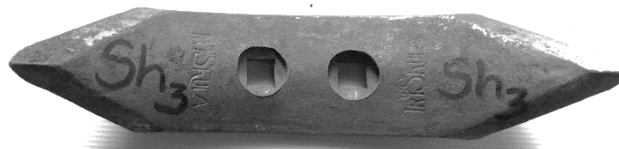

**Shovel (Sh<sub>3</sub>)**

**Fig. 1: Selected commercially available cultivator tines and reversible shovel**

### **2.1. Dimensions of cultivator tines as per BIS codes**

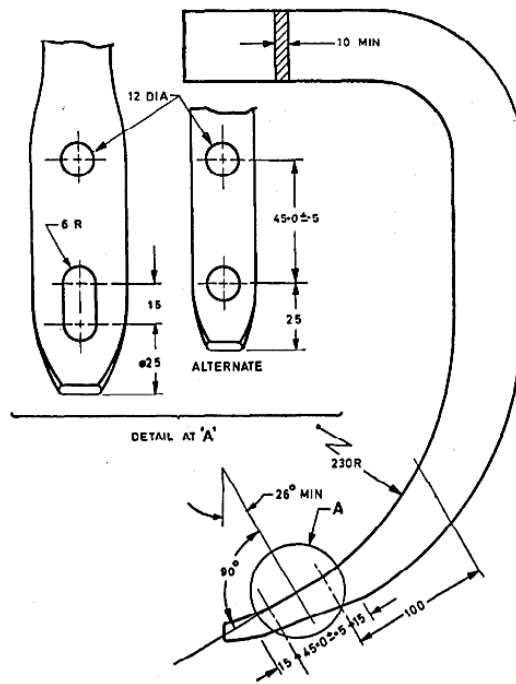

Fig. 2: Dimensions of tine as per BIS code IS: 7565 (1) -1975

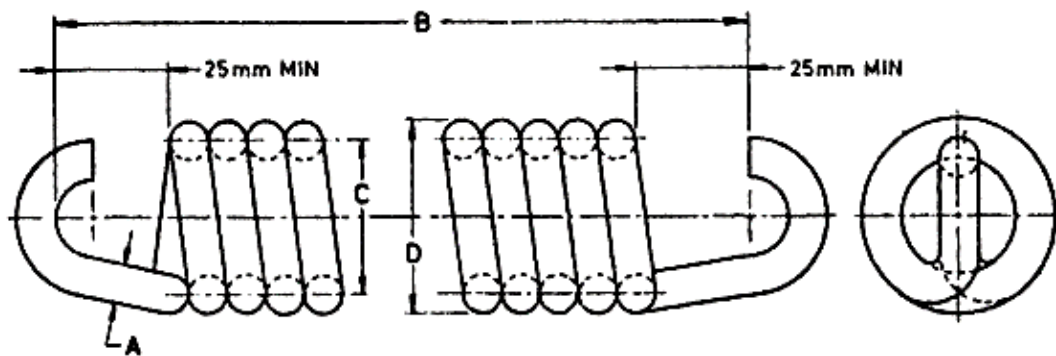
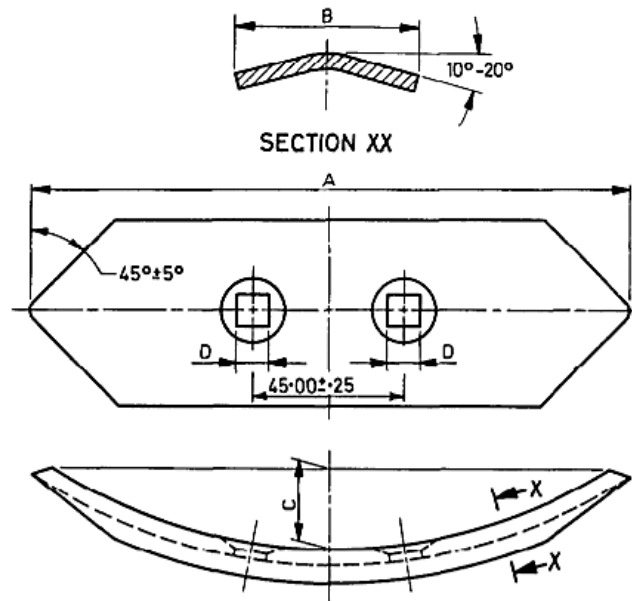

Fig. 3: Dimensions of spring as per BIS code IS: 6638-1972

2.2. Dimensions of reversible shovels as per BIS code IS: 3342-1998



**Fig. 4: Dimensions of reversible shovel as per BIS code IS: 3342-1998**

**Table 1: Dimensions of tine as per BIS code IS: 7565 (1) -1975**

Sr.no	Parameters	BIS dimensions
1.	Length, mm	600
2.	Width, mm	60
3.	Thickness, mm	25
4.	Diameter of holes, mm	12
5.	Centre to centre distance between holes, mm	45±0.5

**Table 2: Dimensions of spring as per BIS code IS: 6638-1972**

Sr.no	Parameters	BIS dimensions
1.	Wire diameter (A), mm	8
2.	Length of spring (B), mm	300
3.	Outside diameter of spring (D), mm	50
4.	Number of coils	27-28
5.	Number of spring per tine	1 or 2

**Table 3: Dimensions of reversible shovel as per BIS code IS: 3342-1998**

Sr.no	Parameters	BIS dimensions
1	Length (A), mm	270 ± 2

2	Width (B), mm	$75 \pm 2$
3	Concavity (C), mm	$35 \pm 1.6$
4	Centre to centre distance (E), mm	$45 \pm 0.25$
5	Hole diameter (D), mm	$15 \pm 0.5$

### 3. Results and Discussion

#### a. Cultivator tines

The dimensions of selected cultivator tines and reversible shovels were assessed by using the measuring tape and vernier calliper. The obtained results were compared with the respective BIS codes. The chosen rigid cultivator tine (CT<sub>1</sub>) had a dimensions of 600×62.27×20.35 mm and spring cultivator tine had 550×165×21.92 mm (Figures 5 and 6). The length of selected rigid cultivator tine was found as same as BIS recommended value. Likewise, width was found 3.78 % wider and thickness was found 22.85 % minimum as compared to BIS recommended value. Similarly, spring cultivator tine measures dimensions which were comparatively varied with BIS recommended values (Table 4).

#### b. Spring

Spring in the selected spring cultivator tine had a dimensions mentioned in Table 4. Length was found 55.6 per cent longer than BIS recommended spring length. Also wire diameter and outside diameter were found 2.56 and 4.16 % smaller than BIS recommended values. The selected spring consists of 27 number of coils and 2 springs per tine, which were almost similar to BIS recommended values (Table 5).

#### c. Shovels

##### • Length, width and thickness

Among shovels, Sh<sub>1</sub> had higher dimensions compared to Sh<sub>2</sub>, Sh<sub>3</sub> and BIS standard. Sh<sub>1</sub> and Sh<sub>2</sub> were 25.9 and 14.8 % respectively longer and Sh<sub>3</sub> was 8 % shorter than BIS recommended values. Likewise, Sh<sub>1</sub> was 6.6 per cent wider, whereas Sh<sub>2</sub> and Sh<sub>3</sub> were 7.1 and 13.3 % respectively narrower than BIS recommended value. Also, Sh<sub>1</sub> was thicker than Sh<sub>2</sub>, Sh<sub>3</sub> and BIS recommended value (Table 6 and Figure 7).

##### • Concavity

Sh<sub>1</sub>, Sh<sub>2</sub> and Sh<sub>3</sub> measured higher concavity of 100, 114 and 57 % respectively than BIS recommended value (Table 6 and Figure 7).

##### • Hole diameter

The hole diameter of Sh<sub>1</sub>, Sh<sub>2</sub> and Sh<sub>3</sub> measures minimum of 22.95, 28.2 and 14.35 % respectively than BIS recommended value (Table 6 and Figure 7).

- **Centre to centre distance between holes**

The centre to centre distance between holes found same as BIS standard value (Table 6 and Figure 7).

**Table 4: Dimensions of selected cultivator tines**

<b>Tine</b>	<b>A ± 2</b>	<b>B ± 2</b>	<b>C ± 2</b>	<b>D ± 2</b>	<b>E ± 0.5</b>	<b>F ± 0.5</b>
<b>CT<sub>1</sub></b>	600	62.27	20.35	430	12	45
<b>CT<sub>2</sub></b>	550	165	21.92	715	14	46
A- Length (mm), B- Width (mm), C-Thickness (mm), D- height (mm). E- Diameter of holes (mm)F- centre to centre distance between holes (mm)						

**Table 5: Spring dimensions of selected spring cultivator tine.**

<b>Sl.No.</b>	<b>Parameters</b>	<b>Dimensions</b>
1.	Wire diameter (A), mm	7.8
2.	Length of spring (B), mm	467
3.	Outside diameter of spring (D), mm	48
4.	Number of coils	27
5.	Number of spring per tine	2

**Table 6: Dimensions of selected reversible shovel**

<b>Shovel</b>	<b>A ± 2</b>	<b>B ± 2</b>	<b>C ± 2</b>	<b>D ± 0.5</b>	<b>E ± 0.5</b>	<b>F ± 1</b>
<b>Sh<sub>1</sub></b>	340	80	10.30	12.20	45	70
<b>Sh<sub>2</sub></b>	310	70	10	11.70	45	75
<b>Sh<sub>3</sub></b>	250	65	8.15	13.12	45	55
A – Length (mm), B- Width (mm), C- Thickness (mm), D- Hole diameter (mm) E- Centre to centre distance between holes (mm), F- Concavity (mm).						

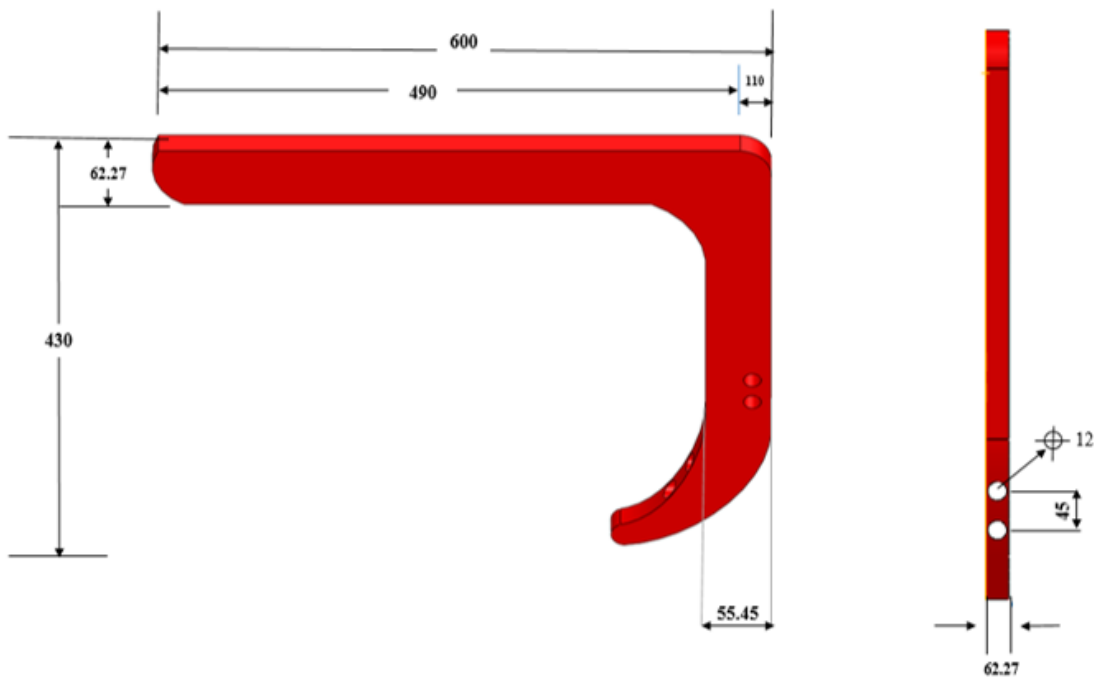

All dimensions are in mm

**Fig. 5: Dimensions of selected rigid cultivator tine**

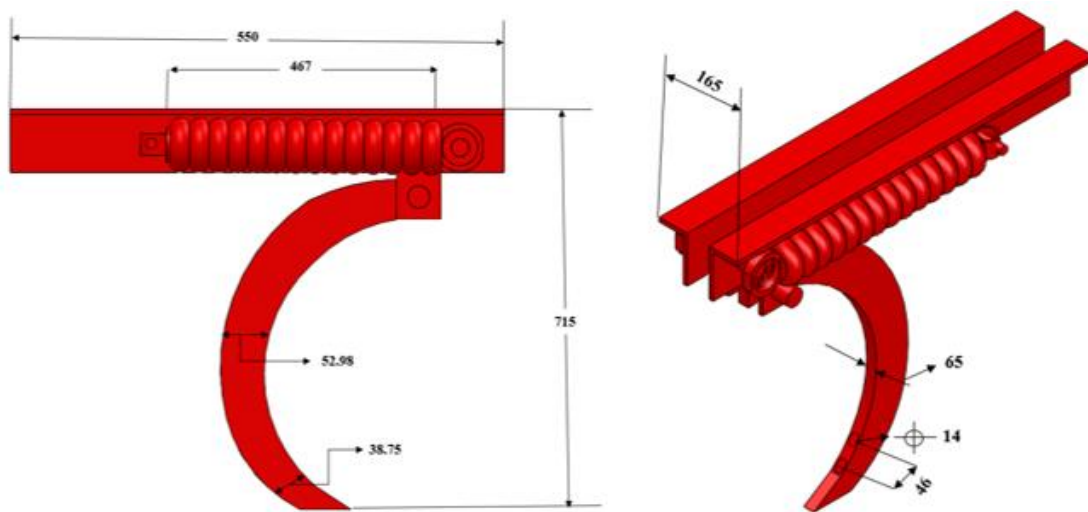

**Fig. 6: Dimensions of selected spring cultivator tine**

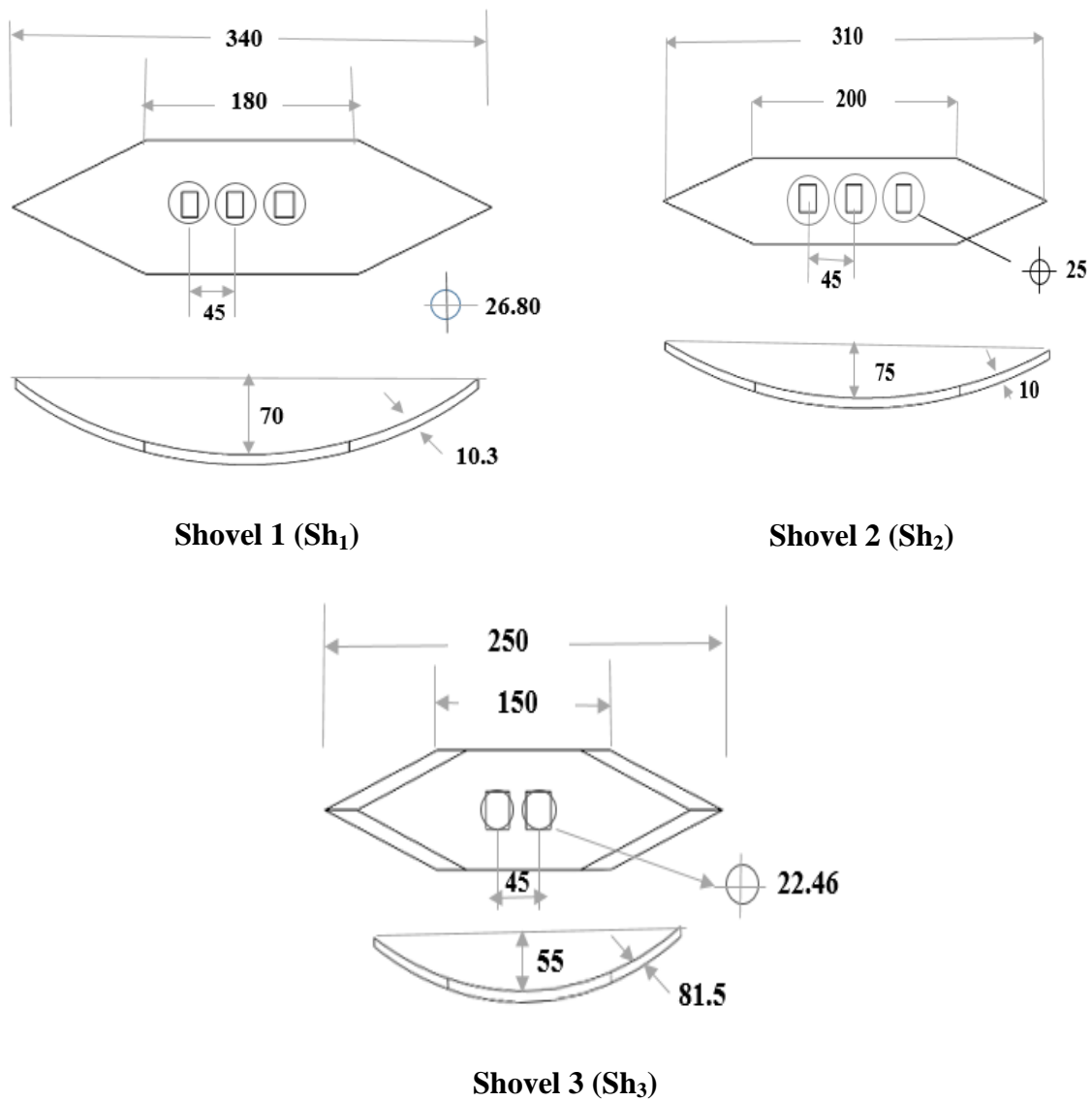

**Fig. 7: Dimensions of selected reversible shovels**

#### **4. Conclusion**

The dimensions of selected rigid and spring cultivator tines vary significantly higher amount as compared to BIS recommended values with respect to all dimensional parameters. Also, spring dimensions in selected spring tine found higher values as compared to BIS standard values. Among shovels, Sh<sub>1</sub> and Sh<sub>2</sub> found higher and Sh<sub>3</sub> found lower values as compared to BIS standard value. The results obtained indicate that excessive or undesired design of the shovels and tines leads in unnecessary manufacturing costs and may also have an impact on the energy and draft requirements and performance of the tools.

## References

1. Anonymous. 2017. Guidelines & regulations of testing of farm machinery. [https://www.iari.res.in/files/Farm\\_Machinery/Test\\_Guidelines.pdf](https://www.iari.res.in/files/Farm_Machinery/Test_Guidelines.pdf)
2. Badegaonkar, U.R., Dixit, G. and Pathak, K.K. 2010. An experimental investigation of cultivator shank shape on draft requirement. *Archives of Applied Science Research* **2**: 246-255.
3. Okoko, P., Umani, K.C. and Onwe, D.N., 2023. Performance evaluation of a spring tine cultivator in a sandy loam soil. *Agricultural Engineering International: CIGR Journal*, 25(2).
4. Jyoti1, B., Ram Reddy, K.V.S., Sawant, C.P., Pandirwar, A.P., Potdar, R.R. and Randhe, R.D. 2019. Predicting draft requirement of tillage implements using pull type loadcell in southern region of Andhra Pradesh, India. *International Journal of Current Microbiology and Applied Sciences***9**: 606-612.
5. Mwiti, F.M., Gitau, A.N. and Mbuge, D.O., 2023. Effects of soil-tool interaction and mechanical pulverization of arable soils in tillage-a comprehensive review. *Agricultural Engineering International: CIGR Journal*, 25(3).
6. Oduma, O., Oluka, S.I., Nwakuba, N.R. and Ntunde, D.I. 2019. Agricultural field machinery selection and utilization for improved farm operations in South-East Nigeria- A review. *Agricultural Engineering***3**: 44-58
7. Sahay, J. 1971. Text book of Elements of agricultural engineering. *Standard publisher's distributors*. New Delhi. India pp: 3-4
8. Verma, A and Guru, P.K. 2014. Development and evaluation of cultivator cum seed Drill. *Article in Ecology, Environment and Conservation* **21**: 1359-1364.
9. T. N. Aruna, G. S. Tiwari and Ajay Kumar Sharma. Effect of Operational Parameters on Draft and Power Requirement of Rigid and Spring Cultivator Tines. *Int.J.Curr.Microbiol.App.Sci* (2020) 9(9): 2488-2498