

DESIGN AND TECHNO-ECONOMIC ANALYSIS OF AN IMPROVED MULTIPURPOSE COOKER STOVE

ABSTRACT

In response to the growing concerns surrounding the adverse health and environmental impacts of inefficient and hazardous traditional cooking fuels and stoves, this research aims to design and assess the performance of an improved multipurpose cooker stove. The study focuses on Zambia, a country deeply affected by air pollution and deforestation due to charcoal and firewood production using inefficient cooking stoves called Mbaula.

The primary objective is to create an economically viable and environmentally friendly cooking stove that addresses the sustainability challenges of traditional cooking practices. The research is guided by key objectives. The study outlines the design process of the improved multipurpose cooker stove, emphasizing the incorporation of sustainable design principles.

The improved multipurpose cooker stove demonstrated a thermal efficiency of 87.49%, significantly higher than the 11.88% thermal efficiency of traditional stoves. This improvement in efficiency is crucial for reducing fuel consumption and maximizing heat transfer during cooking processes. In addition, the research findings showed that the improved multipurpose cooker stove consumed 0.3643 kg/L less fuel compared to traditional stoves. This fuel savings not only reduces the cost of raw materials but also contributes to environmental sustainability by lowering deforestation rates and air pollution. Despite the initial investment cost of the improved cooker stove, the long-term operation costs are lower due to reduced fuel consumption and maintenance expenses.

The study's findings and recommendations hold promise for addressing critical challenges related to clean cooking solutions, environmental preservation, and the well-being of households in Zambia and similar contexts.

Key words: Improved Multipurpose cooker stove, Traditional charcoal stove, Performance

1.0 INTRODUCTION

Background and overview

A clean, sound, and supportable climate is viewed as the underpinning of human existence. (Correa, et al., 2022). To accomplish sustainable development, there is a need for an improved and efficient energy. A third of the world's population, or about 2.4 billion people, cook over open flames or inefficient stoves powered by kerosene, biomass (wood, animal manure, and crop waste), and coal, which causes dangerous indoor air pollution. In 2020, household air pollution was thought to be the cause of 3.2 million annual deaths, including over 237 000 deaths of children under the age of five (World Health Organization , 2021). 6.7 million premature deaths per year are attributed to the impacts of household and ambient air pollution combined. Exposure to household air pollution increases the risk of developing non-communicable diseases such as lung cancer, chronic obstructive pulmonary disease (COPD), ischemic heart disease, and stroke. To reduce indoor air pollution and safeguard public health, it is crucial to increase the use of improved technologies. These include biomass stoves that fulfil the emission targets in the WHO Guidelines, solar energy, electricity, biogas, liquefied petroleum gas (LPG), natural gas, and alcohol fuels. (World Health Organization , 2021). In addition, household air pollution (HAP) accelerates environmental change on a global scale. Biomass burning pollution and fuel demand-related deforestation speed up environmental change, which has significant effects on global health. (Donegan, 2018).

Wood fuel (charcoal and firewood) make up over 70 percent of the national energy consumption in Zambia as only about 25 percent of the population has access to electricity. It is among the most important domestic fuels for low-pay families in Zambia. The nation's low pay is ceaselessly impacted by the low accessibility of maintainable, clean, and dependable energy. Cooking with solid fuels and inefficient cookstoves has adverse effects on human health and the environment. One initiative for sustainable energy provision in urban Zambia has been the introduction of improved cookstoves (ICS) based on sawdust pellets and charcoal briquettes to replace traditional cooking on charcoal braziers that have dominated usage in homes

since the 1930s. (Mulenga, 2019). To improve household air quality, requires defining “clean” for health at point of use. Charcoal is widely available, affordable, and the first choice for domestic cooking for more than 75% of urban Zambians, regardless of income. The charcoal value chain also functions as an economic and social safety net by providing livelihood and employment opportunities for men, women, and youth (Tetra Tech, 2021). The WHO has set guidelines for the quality of indoor air. The guidelines discourage the use of charcoal in homes.

According to the world Bank (2014), dependence on solid fuel cooking in Sub-Saharan Africa (SSA) is a huge and developing issue. Nearly 700 million Africans (82%) use strong energies, for example, wood, charcoal, manure, crop waste, and coal, for their essential cooking needs-a number that will arrive at 850-900 million before the decade's over (The World Bank, 2014). This elevated degree of solid fuel use joined with family dependence on wasteful and risky traditional cookstoves, establishes a first-request general wellbeing emergency: HAP from solid fuel cooking kills almost 600,000 Africans yearly and is currently perceived as the second-biggest health risk factor. (The World Bank, 2014).

The world can't accomplish its objectives of tending to environmental change without moreover tending to the fuel energy need of millions for homegrown and institutional cooking. (Berko, 2018). However, the opposite is the case with rural areas of Zambia, where the population rely heavily on wood fuel. Charcoal is mainly preferred in urban households generally because it is easier to transport and store. Charcoal use contributes to deforestation and air pollution, especially when burned indoors, also damages people's health (Atteridge, et al., 2013).

The main aim of the research is to design an improved multipurpose cooker stove that is economical and environmentally friendly.

Study objectives.

Main objectives

To design an improved multipurpose cooker stove for household cooking.

Specific objectives

- i. To design an improved multipurpose stove.
- ii. To fabricate the designed improved multipurpose cooker stove.

- iii. To assess the performance of the multipurpose cooker stove based on sustainable foundation; Technical, Economic and Environmental and that of the traditional charcoal stove.

LITERATURE REVIEW

Historical review of cooking stoves.

In general, it was noted that "suitable technology" went hand in hand with the global issue of deforestation and the significant consequences of high energy prices throughout the middle and late 1970s. Stoves address innovations as old as the revelation of fire and human civilization. In those chilly times, the reason for the fire was most likely to provide warmth. The utilization of fire to plan and protect food indeed became known in the Middle Palaeolithic, i.e., around 100,000 BC. (Westhoff & Germann, 1995). Following the advancement of domesticated animals and plant cultivation, as well as advancements such as ceramics and the development of mud houses, the stoves reverted to their natural fundamental structure, which has been

around for roughly 12,000 years. It is comprised of stones that hold a cooking pot, a grill, or a ceramic platter. Placed inside the house, sheltered from the wind and rain, or outside in the yard, the stove became the focal point of the home. It was variable in size, simple to introduce, and multi-functional. Further, not only did it serve for smoking, boiling, or frying food but also for heating the space occupied by individuals and animals (Kshirsagar & Kalamkar, 2014). To secure the pot an arrangement of three stones was used, and this kind of fire was called the three stone fire (TSF). The TSF Not only made it possible for a cooking pot to rest securely on it, but it also helped protect the fire from the whims of the wind. The fundamental hindrance to a three stone fire is its low efficiency. Users primarily created the improvements to the cook stove design based on their own experiences. Despite human evolution and the advancements in fuel and stoves, the majority of the estimated 75% of people who live in the developing world still use three-stone or shielded fires for cooking (Kumar, et al., 2015). These drawbacks with the TSF are well documented. When using biomass fuel, smoke is vented into the house rather than outdoors, which leads to health concerns, wastes fuel because heat escapes into the open air, and forces the user to gather more fuel, which may cause more deforestation because wood is used as fuel. When cooking, people, especially women, only use one cooking pot at a time, increasing the risk of burns and scalds. (Woldesemayate & Atnaw, 2020). However, the three-stone fire generally still had the same problems as the open fire, so the shielded fire was changed to a U-shaped mud or mud/stone enclosure with a front opening for fuel feeding and combustion air entry. A "built-in stove" or "mud stove" is an improvement over the TSF. At the top rim of the enclosure, three little humps served as a pot rest, an induction point for secondary air required for improved burning of volatile substances, and an exhaust gas exit. Laboratory testing of mud stoves revealed rapid boiling, high CO and PM emissions, an average thermal efficiency of about 29%, and a moderate safety rating, primarily due to contained fire. (Kshirsagar & Kalamkar, 2014). According to the sustainable Development report (2022), only 15.7% of the population of Zambia cook using clean fuels and technologies. (Jeffrey Sachs, 2022).



Figure 1. Types of stoves (a) Three-Stone Fire stove and (b) mud stove (Donegan, 2018)

According to, (Kaputo, et al., 2023) Although the clean cooking market has advanced substantially, the improved cooking industry in SSA is still very underdeveloped.

The accessibility of these various stove types varies within SSA, and for many residents of the area, finding clean and effective cooking options continues to be difficult. Zambia, on the other hand, use the conventional Mbaula stove, which burns charcoal and has the pot mostly sitting on the fuel. Due to inadequate insulation and an excessive number of holes, it produces a lot of cold extra primary air and has a low combustion temperature. Charcoal serves as the main fuel source for this type of stove. (Luzi, et al., 2019). 83.4% of homes in Zambia use biomass for cooking. More than 46% of the families use a three-stone open-fire stove, primarily burning wood, and more than 36% use traditional stoves (mbaula), primarily burning charcoal. Only 0.4% of people in the population use improved stoves. (Luzi, et al., 2019).

Effects of traditional stoves

Emissions.

Improved cookstoves (ICS) have been shown to reduce emissions that contribute to global warming, protect forests and ecosystems, and reduce HAP, which has a negative impact on health. (Shannon, 2021). Acute lower respiratory infections are among the illnesses brought on by emissions from indoor air pollution. If exposed to emissions, a child has a two to three times greater chance of developing an acute lower respiratory infection. Up to four times as many women who cook with biomass develop chronic obstructive lung illness, such as chronic bronchitis. The use of coal-burning stoves has been directly connected to lung cancer in Chinese women. Additionally, there is evidence connecting indoor air pollution to cataracts, low birth

weight, TB, asthma, and low infant mortality. (Hugh Warwick, 2004). Particulate matter (PM), carbon monoxide (CO), sulphur oxides (SO), and nitrogen oxides (NO_x) are pollutants that are related to incomplete combustion and are frequently connected to indoor air pollution (Berko, 2018). The usage of solid fuels and the manufacturing of charcoal in the area contribute to the Kyoto Protocol's greenhouse gas targets of 120–380 Mt CO_{2e} (0.4–1.2% of the world's CO₂ emissions) and up to 600 Mt CO_{2e} when particulate matter is considered. (Lambe, et al., 2015). More than 300 million tons (MT) of wood are consumed each year throughout SSA because of the manufacture and usage of solid fuels for cooking. (The World Bank, 2014). The figure below shows emissions share from cooking in SSA.

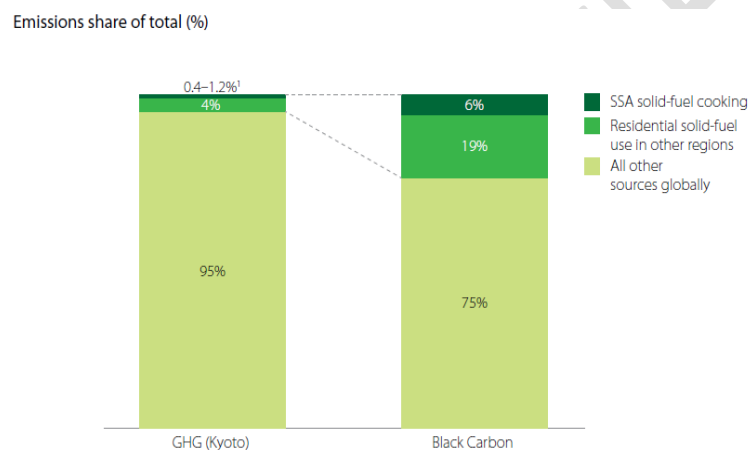

Figure 0. Black carbon and GHG emissions from solid-fuel cooking in SSA (The World Bank, 2014)

To be able to use emissions data to inform decisions, it is crucial to comprehend the typical pollutants linked to poor air quality. (Donegan, 2018). In Zambia 0.4 Gg CO_{2eq} is produced from solid fuels. (Daka, et al., 2019).

Deforestation

Deforestation has disastrous effects on the environment. They range from the devastation of crops and deserts to the erosion of watersheds and flooding. And once the trees are gone, so is the firewood, that up to 90% of people in some developing nations rely on as their main fuel source. Simply, cooking food has become more harder for the world's impoverished. Reducing fuel use and consequently having an impact on the rate of deforestation was one of the main drivers behind the "first wave" of improved stove distribution. Between 30% and 50% more fuel might have been saved by improved wood stoves than what was required to cook over the

TSF.(Partnership for Clean Indoor Air, 2011). ICS have advantages for the environment in addition to the health benefits. An estimated 200,000 hectares of forest are removed annually in Zambia, which is one of the countries with the highest deforestation rates in the world. Due to its predominant use for cooking in households across all income levels in Zambia, the use of charcoal is a major cause of deforestation and forest degradation in Zambia. (Tetra Tech, 2021). (Tetra Tech, 2021), The ICSs seek to lessen the amount of deforestation directly linked to the manufacture of charcoal by reducing the consumption of charcoal and boosting the usage of alternatives, by making alternative technologies and fuels available, affordable, and culturally acceptable.

Design considerations.

Using the Winiarski method of maintaining a constant area under the pot, the Gap required to help in maximizing the amount of escape air was determined. Calculations were made to determine the proper height of the gap under the pot from the combustion chamber's edge. (Bryden, et al., 2005). The combustion chamber's area was calculated, and given that it is cylindrical:

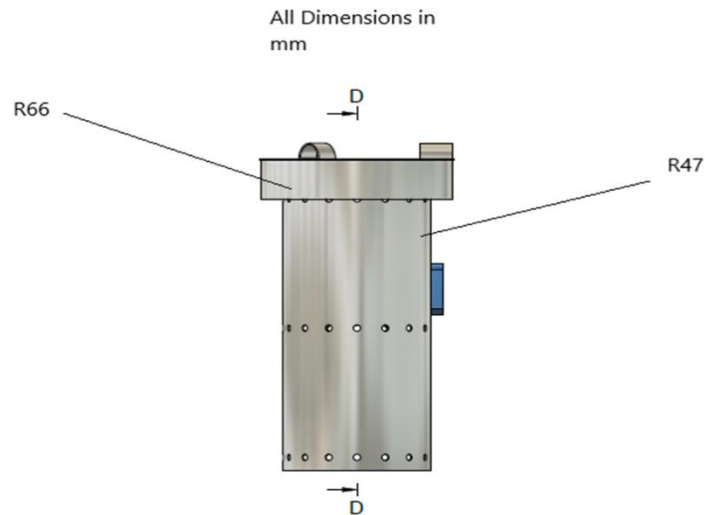

Figure 0. Combustion chamber schematic diagram.

$$A_c = \pi \cdot r_c^2 \quad \text{Equation 0.1}$$

A_c is the area of the combustion chamber, cm^2 .

π is 3.14.

r_c is the radius.

Therefore.

$$A_c = 3.14 \times (4.7)^2$$

$$69.363 \text{cm}^2$$

The combustion chamber's circumference was calculated using the following steps:

$$A_c = 2 \cdot \pi \cdot r_c \quad \text{Equation 0.2}$$

C_c = Circumference of the combustion chamber

Therefore.

$$C_c = 2 \times 3.14 \times 4.7$$

$$= 29.516 \text{ cm}$$

The gap required between the combustion chamber's top edge and the bottom of the pot was calculated by.

$$G_c = A_c / C_c \quad \text{Equation 0.3}$$

Therefore.

G_c is.

$$69.363 / 29.516$$

$$= 2.35 \text{ cm}$$

Design

The method used to create a cook stove design is crucial for creating improved, more effective cook stoves. An ideal cook stove design was produced by applying fundamental design principles, material preferences, and availability (Wrangham, 2003). Designers can create a solution and increase the likelihood that their objectives will be met with the aid of structured design processes. The design process had both the mechanical and electrical parameters: A thermal simulation was conducted in fusion 360 and a circuit diagram was developed using app.diagrams.net as shown in the image below.

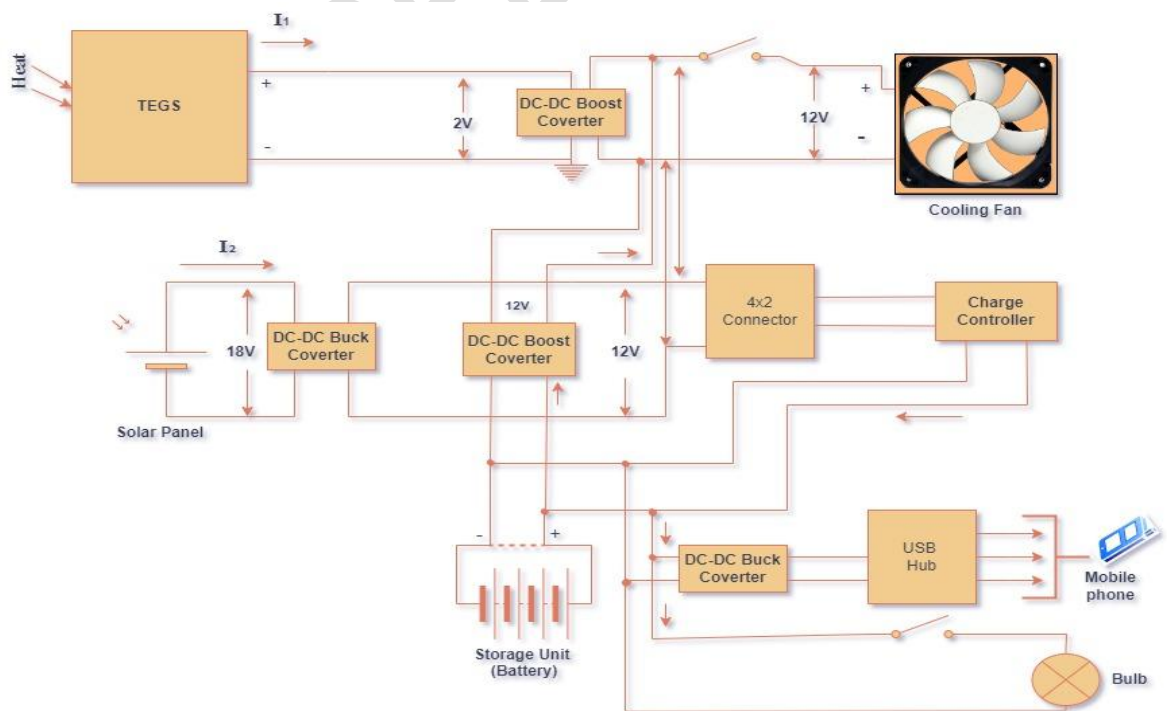

Figure 4. ICS circuit diagram.

Structured design processes provide a framework that assists designers in developing solutions and increasing the probability of achieving their objectives.

Power Generated

The power generated by four thermoelectric modules was calculated every 30 seconds. The test yielded several variables, including the time taken to reach boiling point (in minutes), thermal efficiency (expressed as a percentage), power generated from the TEGs, specific energy consumption, and specific fuel consumption. Standard tests conducted during the experiment include the following:

RESULTS AND DISCUSSIONS

This chapter encompasses the outcomes and analysis of the objectives outlined in the thesis. It encompasses the design and fabrication process, as well as the testing of the improved multipurpose cooker stove. The design and fabrication procedures followed a three-step approach as outlined in Chapter 3, with the initial two stages focusing on design and the third stage dedicated to performance.

Objective 1: To design the improved multipurpose cooker stove.
A 2-D drawing of the ICS designed using fusion360.

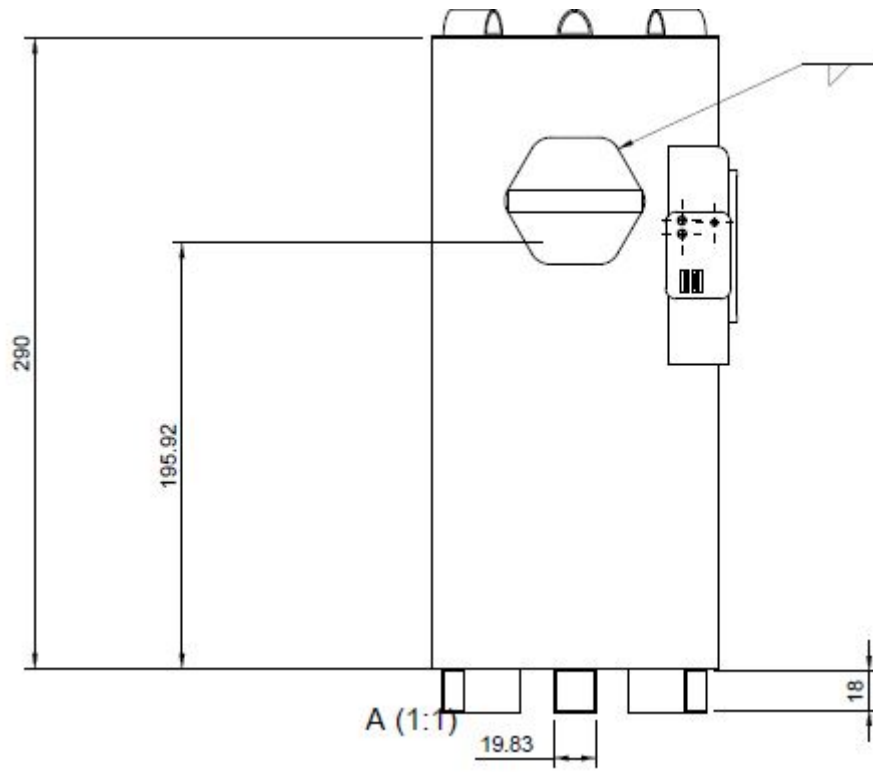

Figure 5. 2-D cross section.

UNDER PEER REVIEW



Figure 6.a. ICS rendered image.



Figure 6.b. Cross-section of ICS.

Objective 2: To fabricate the proposed multipurpose ICS.

Combustion Chambers

The fabrication process commenced with the construction of the outer casing of the cook stove, followed by the creation of the combustion chamber, heat collector and finally, stands were made for the outer casing and the pot. The outer casing of the stove was made up of Galvanised steel and the inner casing made up of stainless steel. The folding of the combustion chambers was done using the track ballast. Holes for natural and forced draft were made using the rivets. The distance of the pot stand was 3cm.



Figure 7. Fabrication of outer casing and combustion chamber.

To complete the design and fulfil the intended functionality of the multipurpose ICS, essential components such as the TEGs (Thermoelectric Generators), solar panel, and electric fan are appropriately installed. The electric fan serves the purpose of providing forced draft and cooling the cold side of the TEGs, thus contributing to the overall functionality of the system. The heat sink dissipates heat from the TEG which improves the efficiency of the TEG depending on how much heat is extracted from its cold side.



Figure 8. TEG testing on the ICS.

Objective 3: To assess the performance of the multipurpose cooker stove based on sustainable foundation; Technical, Economic and Environmental and that of the traditional charcoal stove.

The ICS was tested to assess its performance. The first recorded parameter of interest is temperature; How long it takes to boil 2L of water in a pot.

Ignition.

The pellets were ignited using 10mL kerosene. Immediately, the fire started the pot was placed on the stove. The multipurpose ICS was tested on a clear day with a recorded minimum, maximum and average ambient temperatures of 23°C, 32°C and 27.25°C respectively on the improved cooker stove. By means of forced draft the air entered the combustion chamber and temperature readings were taken at intervals of 1 minute until the water boiled.

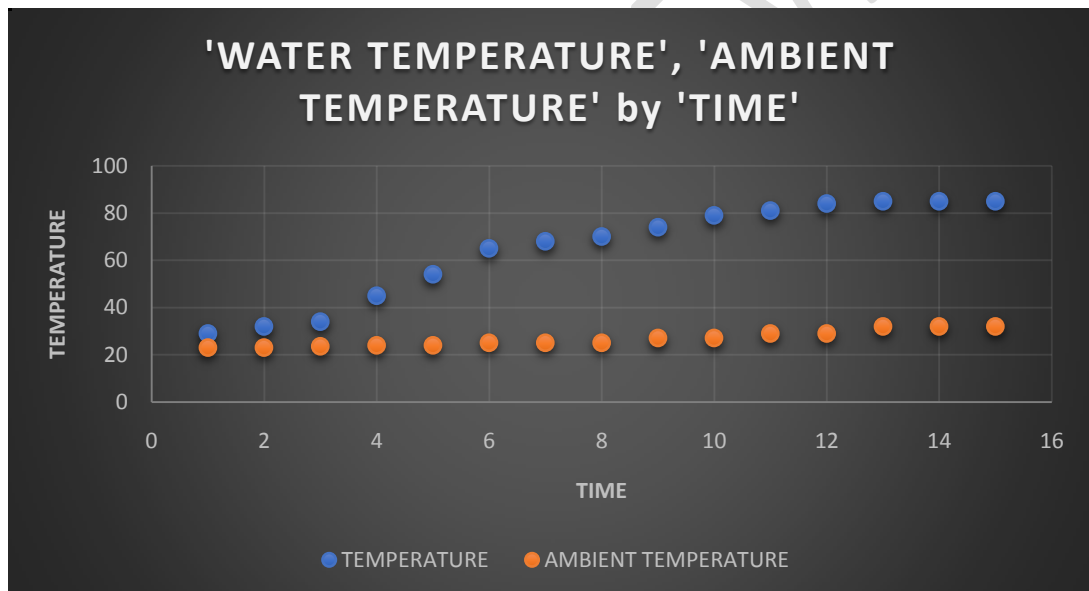

Figure 9. A graph of temperature against time for ICS for the WBT.

Subsequently, the pot was taken off the stove, and the fire was promptly extinguished using dry sand. The concluding measurements and recordings included the ultimate weight of the remaining water and pellets, as well as the ultimate temperature of the water. The tests were conducted on the 31st of July 2023. Tests results for the water boiling test are given in Table 11.

Table 1. ICS WBT test results.

Ambient temperature	32°C
Initial water temperature, T_i	29°C

Final water temperature, T_f	87°C
Time spent to boil	14 minutes
Weight of empty pot,	0.47 Kg
Initial weight of pellets, m_f	0.16 Kg
Weight of pellets after boil, m_i	0.039 Kg
Initial weight of water, w_f	2.386 Kg
Total weight of water after Boiling, w_i	1.52 Kg
Total weight of evaporated water,	0.866 Kg

The table shows the water temperature readings at different time intervals during the water boiling test for the traditional cooker stove. The initial water temperature was 18°C, and the final temperature was 87°C, indicating that the water was successfully boiled. The time taken to boil the water was 45 minutes.

The temperature of the water increased gradually over time, with a slow increase in the first few minutes and a more rapid increase towards the end of the test. This is expected as the heat output of the stove increases as the fire burns more efficiently and the pot heats up.

Overall, the water boiling test for the traditional cooker stove was successful in boiling the water, but it took a longer time compared to the improved multipurpose cooker stove (ICS). The ICS was able to boil the same amount of water in just 14 minutes, which is significantly faster than the traditional stove.

Voltage of TEGs

The voltage from the TEGs was collected while boiling 2L of water and the graph of voltage against time was plotted.

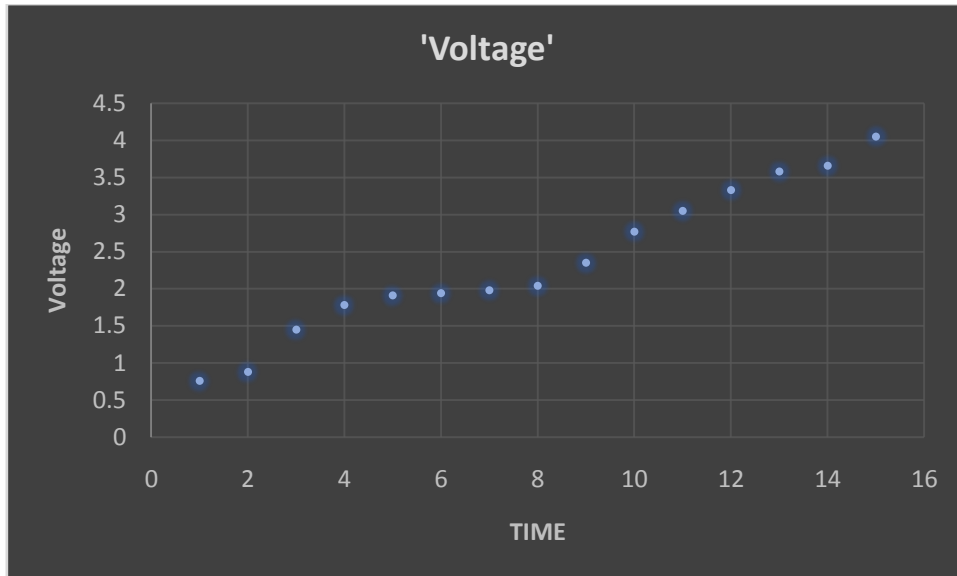

Figure 10. TEG Voltage during WBT

The graph shows that the voltage output of the TEG increases as the temperature of the improved cooker increases. This is because the TEG is more efficient at converting heat energy into electrical energy at higher temperatures. The TEGs were connected to a DC-DC boost converted that not only increased the voltage to 12V but also ensured stable output voltage. The Maximum voltage measured from the TEGs was 4.05V.

Amount of Energy developed from Biomass for ICS.

Using **Error! Reference source not found.** the mass of evaporated water is given as

$$2.386 - 1.52$$

$$= 0.866 \text{ kg}$$

While the mass of boiled water is given by **Error! Reference source not found.**

$$1.52 - 0.474$$

$$= 1.05 \text{ kg}$$

Initial weight of pellets is 0.16kg

Combusted weight of pellets $m_c = 0.16 - 0.039$

$= 0.121 \text{ kg}$

$$q_i = m_c \times NCV$$

The input energy from the pellets

$$\begin{aligned} &= q_i = (LHV \times m_f) - (HHV \times m_v) \\ &(17300KJ/kg \times 0.16kg) - (18800KJ/kg \times 0.121kg) \\ &= 493 KJ \end{aligned}$$

Amount of Energy developed from Biomass for TCS.

The mass of evaporated water for the TCS is given as:

$$\begin{aligned} &= 2.386 - 1.112 \\ &= 1.274 Kg \end{aligned}$$

The mass of boiled water is:

$$\begin{aligned} &= 1.274 - 0.474 \\ &= 0.8 Kg \end{aligned}$$

Initial weight of charcoal = 0.991 kg

Combusted weight of charcoal $m_v = 0.991 - 0.349$

$$= 0642 Kg$$

$$q_i = (LHV \times m_f) - (HHV \times m_v)$$

$$q_i = (28400 \times 0.991) - (29600 \times 0.642)$$

$$9141.2 KJ$$

Therefore, the input energy from the charcoal is 9141.2 KJ.

The LHV and HHV used in the experiment for the charcoal is 28400 KJ/Kg and 29600 KJ/Kg respectively.

Sensible Heat

Heat energy produced by the fuel for ICS.

Heat energy produced by pellets = Mass of pellets used \times LHV of pellets

$$0.16kg \times \frac{17300KJ}{kg} = 2768KJ$$

Heat energy produced by the fuel for TCS.

Heat energy produced by pellets

$$= \text{Mass of charcoal used} \times \text{LHV of charcoal}$$

$$0.991kg \times \frac{28400KJ}{kg} = 28144.4KJ$$

Heat energy produced by the TEG.

Heat energy consumed by TEG = TEG Power output × Operation Time

TEG Power output = Maximum voltage from TEG × Current from TEG

$$Power\ output\ of\ TEG = 4.05V \times 1.5A = 6.075W$$

$$TEG\ operation\ time = 14\ minutes \times \frac{60\ seconds}{minute} = 840\ seconds$$

$$Heat\ energy\ by\ TEG = 6.075W \times 840\ seconds = 5103\ J$$

Thermal efficiency of ICS.

$$Thermal\ efficiency = \frac{1.916 \times 4.182 \times 58 + 0.866 \times 2260}{17300 \times 0.16} = 87.496\%$$

Thermal efficiency of TCS.

$$Thermal\ efficiency = \frac{1.916 \times 4.182 \times 58 + 1.274 \times 2260}{28400 \times 0.991} = 11.88\%$$

Specific fuel consumption for ICS.

Using **Error! Reference source not found.**

Where mass of fuel burned is 0.121 kg and the volume of the water boiled is 0.866kg/1kg/L for ICS is

$$\begin{aligned} SFC &= \frac{0.121}{0.866} \\ &= 0.1397kg/L \end{aligned}$$

Specific fuel consumption for TCS.

$$\begin{aligned} SFC &= \frac{\text{fuel used(kg)}}{\text{water boiled(L)}} \\ SFC &= \frac{0.642}{1.274} \\ &= 0.504\ kg/L \end{aligned}$$

Thermal ISO tier.

The high thermal efficiency of 87.496% for the ICS means that the stove can operate efficiently and save fuel as compared to the efficiency of the TCS which is 11.88%. Testing the multipurpose ICS gave remarkable results of fuel consumption. With a SFC of 0.1397kg/L for ICS and 0.504 kg/L for TCS, it was clear that the ICS used less fuel consumption to heat water in a short period of time. The ICS is classified under tier 5, while the TCS is classified under tier 1 of thermal efficiency of international organization for standardization (ISO) tiers. A lower SFC indicates a more efficient stove. This means that the stove can boil water using less fuel. Improved cookstoves typically have an SFC that is 25-85% lower than traditional cookstoves.

Time saving analysis.

Using **Error! Reference source not found.**

The time spent to boil 2 L of water to 87 degrees using TCS is 45 Minutes, while that of an ICS is 15 Minutes.

Therefore, the time saving analysis is 30 minutes.

Emissions.

Comparative analysis was made between an ICS cooker and that of the traditional charcoal cooker, while conducting the WBT, the indoor air pollution meter was placed within close range of the stove. The first test conducted was on the ICS and the following results were obtained.

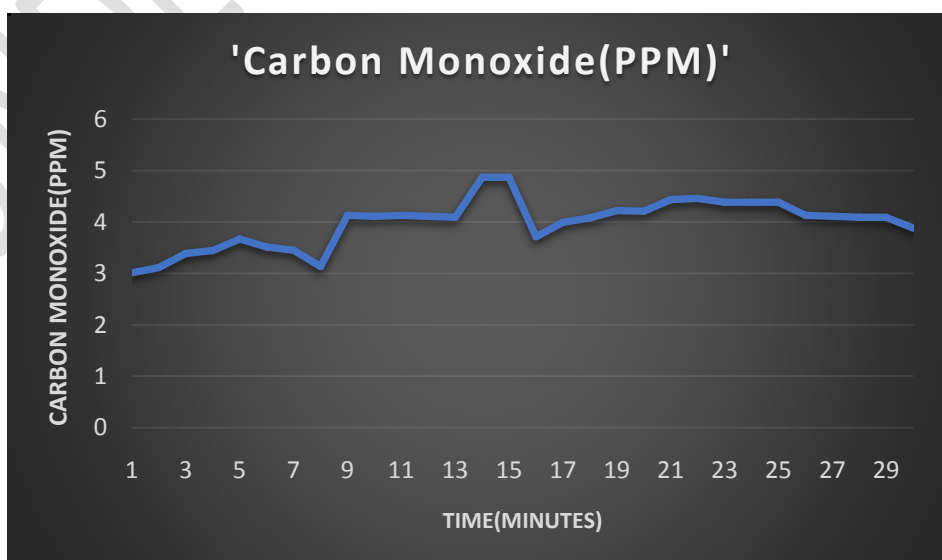

Figure 11. CO emissions from ICS.

The graph shows the concentration of Carbon Monoxide (CO) in parts per million (PPM) over a period of 30 minutes. The highest concentration recorded was 4.87 PPM at minute 14 and minute 15. The lowest concentration recorded was 3.01 PPM at minute 1, the average recorded was 3.985 PPM. The National Ambient Air Quality Standards (NAAQS) for CO is 9 PPM for an 8-hour average and 35 PPM for a 1-hour average. The results from the ICS does not exceed the NAAQS for CO, which means that the air quality is within the acceptable range.

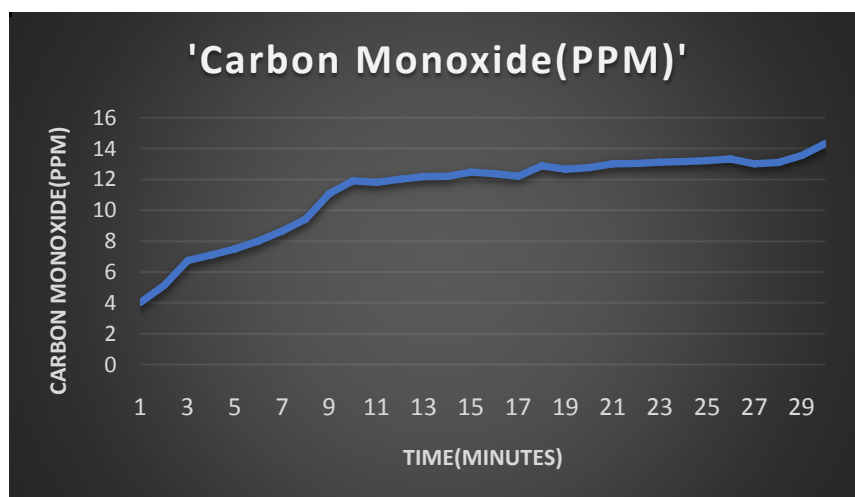

Figure 12. CO emissions from a TCS.

The graph shows the Carbon Monoxide (CO) emissions from a Traditional cooker stove over a period of 30 minutes. The CO emissions increase as the time increases, with the highest value of 14.33 PPM recorded at 30 minutes. The lowest value of 4.03 PPM was recorded at 1 minute.

The National Ambient Air Quality Standards (NAAQS) for carbon monoxide are set by the Environmental Protection Agency (EPA) in the United States. The primary standard for CO is 9 parts per million (ppm) over an 8-hour period and 35 ppm over a 1-hour period. The graph shows that the CO emissions from the Traditional cooker stove exceed these standards for most of the time. This means that the stove poses a health risk to the users and the environment.

Economical Consideration.

INITIAL INVESTMENT

We note that, the initial investment which is capital expenditure (CAPEX) that was used to build the stove is 6285 Kwacha inclusive of labour as shown in **Error! Reference source not found..** Annual operating expenses (OPEX)

There may be ongoing expenses, such as maintenance or occasional replacement of components, such as TEGs which we can estimate as a percentage of the initial investment. Let's assume 5% of CAPEX as OPEX. The Major costs of the system is the TEG, battery, and the solar panel. The TEG and the solar enable for forced and making the stove a multipurpose that assists in lighting and phone charging while the battery is used as a storage.

Therefore OPEX.

$$0.05 \times 6285 = 314.25 \text{ ZMW}$$

While the cost to build the ICS is more as compared to the TCS on the Zambian market, the ICS stove has numerous advantages to both the environment and the users. The cost of the traditional cook stove (Mbaula) costs 60 ZMW.

To build 100 ICS costs 150500 ZMW meaning to build 1 ICS costs 1505 ZMW. Therefore, it is cheaper to manufacture ICS in mass production than to manufacture one.

Therefore, the OPEX of mass production is given as:

$$0.05 \times 150500 = 7525 \text{ ZMW}$$

CONCLUSIONS AND RECOMMENDATIONS

Conclusion

As part of the 17 sustainable development goals set forth, with the ambition of having 20 million households adopt improved cooking stoves and fuels by 2030, it has become crucial for both industry and academia to engage in research efforts aimed at contributing to the successful production and distribution of improved cookstoves. The design and performance of the Improved Cook Stove (ICS) addresses several Sustainable Development Goals (SDGs) outlined by the United Nations.

Adhering to the established principles and design guidelines, the design and fabrication of an improved multipurpose cook stove was accomplished successfully. The primary goal of developing a user-friendly, easily operable, and aesthetically pleasing cook stove was achieved with great success.

Communities that engage in extended cooking sessions are the most likely beneficiaries of the specially designed improved cook stove for the purposes outlined in this thesis. When considering specific fuel consumption and processing rates during a cooking session, the improved multipurpose cook stove presents a distinct advantage over the traditional cook stove. The SFC for the Improved cooker was 0.1397 kg/L as compared to the traditional cooker that is 0.504kg/L, therefore 0.3643kg/L of fuel was saved using the improved cooker. In addition, the improved cooker stove boiled water 35 minutes less than that of the traditional cooker posing a risk to the users of the traditional cooker as they would be exposed to the emissions.

In terms of health benefits, the improved institutional cook stove surpasses the traditional cook stove by reducing carbon monoxide. Furthermore, the emissions from the improved multipurpose stove are significantly below The National Ambient Air Quality Standards (NAAQS) for CO is 9 PPM for an 8-hour average and 35 PPM for a 1-hour average. The highest concentration recorded was for the improved cooker stove was 4.87 PPM, while that of the traditional cooker was 14.33 PPM. The results from the ICS does not exceed the NAAQS for CO as compared to the CO emission from the traditional cooker stove which exceed these standards for most of the time. This means that the stove poses a health risk to the users and the environment. Further, the incorporation of fiberglass wool insulation in the improved cooker stove

has proven instrumental in enhancing thermal efficiency, reducing heat loss, and optimizing energy consumption. The thermal efficiency of the improved multipurpose cooker stove was 87.49% while that of the traditional cooker stove was 11.88%.

The findings of this study underscore the necessity of promoting the adoption of improved cook stoves as a replacement for underperforming traditional cook stoves. This transition is pivotal in supporting users and safeguarding the health and well-being of those affected using cook stoves in the pursuit of a cleaner and healthier environment.

Recommendations

The tests results conducted were for WBT and did not involve other tests. This research can be a foundation for developing other tests such as the controlled cooking test and kitchen performance tests. With enough resources the research can be improved. It is important to note that the data provided is only for a period of 30 minutes on the improved cooker stove and may not be representative of the air quality over a longer period. In addition, there needs to be an improved study on the insulation of the stove. It is recommended to monitor the air quality over a longer period to get a more accurate picture of the air quality in the area.

Future works

- a) Long-Term Monitoring: Conducting long-term monitoring studies to assess the performance and durability of the improved multipurpose cooker stove. This would provide valuable data on its efficiency and user satisfaction over an extended period.
- b) User Feedback and Iterative Design: Gathering feedback from end-users on the usability and functionality of the cooker stove to inform iterative design improvements. User-centered design approaches can help enhance the stove's performance and user experience.
- c) Scaling Up Production: Exploring opportunities for scaling up the production and distribution of the improved multipurpose cooker stove to reach a larger market. Collaboration with local manufacturers and stakeholders could facilitate mass production and wider adoption.
- d) Integration of Smart Technologies: Investigating the integration of smart technologies, such as sensors and IoT connectivity, to enhance the

functionality and monitoring capabilities of the cooker stove. Smart features could improve energy efficiency and user convenience.

- e) Exploration of Alternative Fuels: Researching the compatibility of the cooker stove with alternative and sustainable fuels to provide users with more options for clean cooking. Testing different fuel sources can expand the stove's versatility and environmental impact.

REFERENCES

- Amaral, S. S., Jr, J. A. d. C., Costa, M. A. M. & Pinheiro, C., 2016. *Particulate Matter Emission Factors for Biomass Combustion*, Brazi: s.n.
- Atteridge, A., Heneen, M. & Senyagwa, J., 2013. *Transforming Household Energy Practices Among Charcoal Users in Lusaka, Zambia: a User-Centred Approach*, Stockholm: Stockholm Environment Institute.
- Bailis, R., 2004. *Controlled Cooking Test*, s.l.: Shell Foundation.
- Bantu, A. A., Nuwagaba, G., Kizza, S. & Turinayo, Y. K., 2018. Techniques, Design of an Improved Cooking Stove Using High Density Heated Rocks and Heat Retaining. *Journal of Renewable Energy*.
- Benjamin, W., 2005. *An Improved Wood Cookstove*. Hartford: Trinity College.
- Berko, E., 2018. *Design, construction and assesment of an improved hybrid charcoal-LPG cookstove*. Accra: Berko, Emmanuel.
- Boafo-Mensah, G., Darkwa, K. M. & Laryea, G., 2020. Effect of combustion chamber material on the performance of an improved biomass. *Case Studies in Thermal Engineering*.
- Bryden, M. et al., 2005. *Design Principles for Wood Burning*. s.l.:Partnership for Clean Indoor Air.
- Cekdin, C., Nawawi, Z. & Faizal, M., 2020. The usage of thermoelectric generator as a renewable energy source. *TELKOMNIKA Telecommunication, Computing, Electronics and Control*, pp. 2186-2192.
- Chidzugwe, R., 2020. *Innovative Solar Cooker, Transforming Households*. [Online] Available at: <https://www.kenyacic.org/2020/11/innovative-solar-cooker-transforming-households/> [Accessed 12 April 2023].
- Clean Cooking Alliance, 2022. *CLEAN COOKING INDUSTRY SNAPSHOT*, Washington DC: s.n.
- Community Markets for Conservation, 2019. *Improved Cookstoves Program for Zambia*. [Online]

Available at: chrome-extension://efaidnbnmnibpcajpcglclefindmkaj/https://rise.esmap.org/data/files/library/zambia/Documents/Clean%20Cooking/Zambia_Transformation%20carbon%20web%20site.pdf

Correa, F. d. A. et al., 2022. *Environmental Justice*, NEW YORK: One United Nations Plaza.

Daka, J. P. et al., 2019. *THIRD NATIONAL COMMUNICATION TO THE UNITED NATIONS FRAMEWORK CONVENTION ON CLIMATE CHANGE*, Lusaka: s.n.

Damilola, O., 2022. Solving energy poverty power. *beyond the grid*, p. 5.

DeFoort, M. et al., 2009. *Stove Manufacturers Emissions & Performance Test Protocol (EPTP)*. Colorado: Shell Foundation.

Donegan, J., 2018. *Design and Implementation of a Ferrocement Improved Cookstove in Rural Panama*. South Florida: Graduate School at Scholar Commons.

Donegan, J., 2018. *Design and Implementation of a Ferrocement Improved Cookstove in Rural Panama*. Florida: s.n.

Eberhard, A., Rosnes, O., Shkaratan, M. & Vennemo, H., 2011. *Africa's Power Infrastructure: Investment, Integration, Efficiency*. Washington DC: The World Bank.

FAO, 1986. *Wood gas as engine fuel*. [Online]
Available at: <https://www.fao.org/3/t0512e/T0512e00.htm#Content>
[Accessed 3 July 2023].

Furu, M. S., Lillehammer, L. & Grimsby, L. K., 2020. *Study on the Potential of Increased Use of LPG for Cooking in Developing Countries*. s.l.:s.n.

Global Alliance For Clean Cookstoves, 2020. *DELIVERING ON THE SDGS THROUGH CLEAN COOKING*, s.l.: s.n.

Hankey, S. et al., 2015. *Using objective measures of stove use and indoor air quality to evaluate a cookstove intervention in rural Uganda*. Uganda: Elsevier Inc.

Hugh Warwick, A. D., 2004. *Smoke – the Killer in the Kitchen*. London: ITDG.

J.B.Kandpal, C. C., 1995. Indoor air pollution from domestic cookstoves using coal, kerosene and LPG. *Energy Conversion and Management*, pp. 1067-1072..

Jeffrey Sachs, G. L. C. K. G. F. F. W., 2022. *Sustainable Development*, United Kingdom: University Printing House.

KANDPAL, J. B., MAHESHWARP, R. C. & KANDPAL, T. C., 1994. *INDOOR AIR POLLUTION FROM DOMESTIC COOKSTOVES USING COAL, KEROSENE AND LPG*, New Delhi: s.n.

Kaputo, K., Mwanza, M. & Talai, s., 2023. A review of improved cooker stove utilization levels, challenges and benefits in sub-saharan africa. *Journal of energy research and review*, 14(1).

- Kažimírová, V. & Opáth, R., 2016. *Biomass combustion emissions*, s.l.: s.n.
- Kisambira, P., 2009. *jugendhilfe*. [Online]
Available at: <https://www.jugendhilfe-ostafrika.de/short-report-on-the-solar-cooker/>
[Accessed 18 April `2023].
- Kshirsagar, M. P. & Kalamkar, V. R., 2014. A comprehensive review on biomass cookstoves and a systematic approach for modern cookstoves design. p. 25.
- Kumar, A., Prasad, M. & Mishra, K. P., 2015. Historical Review Of Biomass Cook stove Development. p. 5.
- Kumar, R. & Shukla, S. K., 2015. *Cooking: Wood Cook Stoves*.
- Lai, C., 2017. *Power Generation from Salinity Gradient Solar Ponds Using Thermoelectric Generators*. Melbourne: RMIT University.
- Lambe, F., Jürisoo, M., Wanjiru, H. & Senyagwa, J., 2015. *Bringing clean, safe, affordable cooking energy to households across Africa: an agenda for action*, Washington, DC: s.n.
- Learnabout electronics, 2023. *Buck Converters*. [Online]
Available at: <https://www.learnabout-electronics.org/PSU/psu31.php>
[Accessed 9 August 2023].
- Leeuwen, R. V., Evans, A. & Hysen, B., 2017. *increasing the Use of liquefied Petroleum Gas in Cooking in Developing Countries*, Washington DC: The World Bank.
- Lillwhite, M., 1984. *IMPROVED COOKSTOVE TRAINING MANUAL*. Denver: Peace Corps.
- Luzi, L. et al., 2019. *ZAMBIA Beyond connections*, Washington DC: The World Bank Group.
- Mohammed, A., 2020. *Development and Performance Evaluation of Thermoelectric Stove using CFD*. Addis Ababa: s.n.
- Mouser electronics, 2020. *An Introduction to Buck, Boost, and Buck/Boost Converters*. [Online]
Available at:
https://www.mouser.com/pdfDocs/Introduction_to_Buck_Boost_BuckBoost.pdf
[Accessed 9 August 2023].
- Mulenga, M. M., 2019. *Assessing the awareness, adoptability and sustainability of improved pellet cook stoves of low income households in Lusaka, Zambia..*
s.l.:Department of Earth Sciences.
- Muna Thapa, L. S., 2015. *ANALYSIS OF AVAILABLE MODELS OF IMPROVED COOK STOVES (ICS) AND THEIR SUITABILITY IN DIFFERENT ECOLOGICAL ZONES IN NEPAL*, Nepal: s.n.

Mutuku, K., 2013. *DESIGN AND PERFORMANCE EVALUATION OF A BIOMASS GASIFIER: CASE STUDY OF COFFEE AND RICE HUSKS*, Nairobi: s.n.

O'Shaughnessy, S. et al., 2012. Small scale electricity generation from a portable biomass cookstove: Prototype design and preliminary results. *Elsevier*.

Odongo, S., 2017. *Factors affecting the adoption of improved cookstoves*. Nairobi: s.n.

Partnership for Clean Indoor Air, 2011. *Test Results of Cook Stove Performance*. United States: Aprovecho Research Center.

PNGWing , n.d. [Online]

Available at: <https://www.pngwing.com/en/free-png-zbqkd>
[Accessed 19 April 2023].

Pol, A. et al., 2021. Design, Fabrication and Testing of a Forced Draft Biomass Cook Stove. *International Journal of Advanced Research in Science, Communication and Technology (IJARSCT)*, pp. 2581-9429.

Professional, 2018. *Electric Hot Plate Hobs*. [Online]

Available at: <chrome-extension://efaidnbmnnnibpcajpcglclefindmkaj/https://www.sqprofessional.com/manuals/4010-4011-Electric-Hot-Plate-Hobs.pdf>
[Accessed 18 April 2023].

Roth, C., 2011. *Micro Gasification: Cooking with gas from biomass*, s.l.: GIZ HERA.

Shannon, L., 2021. *The Role of Social Capital in Improved Cookstove Adoption in Lusaka, Zambia*. Michigan: s.n.

Simon, G. L. et al., 2014. Energy for Sustainable Development. *Current debates and future research needs in the clean cookstove sector*, pp. 49-57.

Stewart, B., 1987. *Improved Wood, Waste And Charcoal Burning Stoves. A Reactionary's Manual*. London, Uk.: s.n.

Tetra Tech, 2021. *ALTERNATIVES TO CHARCOAL Political Economy Analysis of Zambia's Charcoal Value Chain*, Burlington: United States Agency for International Development.

Tetra Tech, 2021. *USAID ALTERNATIVES TO CHARCOAL CONSUMER PREFERENCES*, Vermont: s.n.

The Energy Progress, 2022. *ACCESS TO CLEAN FUELS AND TECHNOLOGIES FOR COOKING*, s.l.: s.n.

The World Bank, 2011. *Household Cookstoves, Environment, Health, and Climate Change: A New Look at an Old Problem*. s.l.: s.n.

The World Bank, 2014. *Clean and Improved Cooking in Sub-Saharan Africa*, Washington: s.n.

Théophile Vitoussia, et al., 2021. Jean-François Brilhac. *SN Applied Sciences*.

Umogbai, V. I. & O. J. G., 2011. Development And Evaluation Of A Biomass Stove. *Journal Of Emerging Trends In Engineering And Applied Sciences (Jeteas)*, pp. 2–3, 514–520.

Umogbai, V. & Orkuma, J., 2011. Development and Evaluation of a Biomass Stove. *Journal of Emerging Trends in Engineering and Applied Sciences*, pp. 2, 514-520..

Urmee, T. & Gyamfi, S., 2014. A review of improved Cookstove technologies and programs. *Elsevier*, pp. 625-635.

Utmel, 2021. *Introduction to buck, boost, and buck-boost converters*. [Online] Available at: <https://www.utmel.com/blog/categories/equipment/introduction-to-buck-boost-and-buck-boost-converters> [Accessed 9 August 2023].

Warwick, H. & Doig, A., 2004. *Smoke – the Killer in the Kitchen*, London: ITDG Publishing.

Westhoff, B. & Germann, D., 1995. *Stove Images*. Frankfurt: Brandes & Apsel Verlag GmbH.

Wikipedia, 2023. *Buck converter*. [Online] Available at: https://en.wikipedia.org/wiki/Buck_converter [Accessed 9 August 2023].

Woldesemayate, A. T. & At Naw, S. M., 2020. A Review on Design and Performance of Improved Biomass Cook Stoves. *Springer Nature Switzerland AG*, p. 557–565.

World Health Organization (WHO), International Energy Agency (IEA), Global Alliance for Clean Cookstoves (GACC), United Nations Development Programme (UNDP), Energising Development (EnDev) and World Bank, 2018. *ACCELERATING SDG 7 ACHIEVEMENT*, s.l.: United Nations.

World Health Organization , 2021. *Household air pollution and health*. [Online] Available at: <https://www.who.int/news-room/fact-sheets/detail/household-air-pollution-and-health> [Accessed 17 March 2022].

Zube, D. J., 2010. *Heat transfer efficiency in biomass cookstoves*. Colorado : s.n.