

DESIGN AND RETROFITTING OF IRRIGATION PUMPING SYSTEM FOR THE MIDDLE OGUN IRRIGATION PROJECT USING HYDROKINETIC TECHNOLOGY

ABSTRACT

High cost of irrigation pumping by use of fossil fuel has negatively impacted irrigation efficiency on the Middle Ogun Irrigation scheme. Efficient irrigation pumping would improve agricultural productivity and food production on the irrigation scheme. Many attempts have been made by stakeholders to seek alternative energy sources for powering irrigation pumping. This study aimed at the design and retrofitting of the irrigation water pumping system on the Middle Ogun Irrigation scheme using hydrokinetic technology. Hydrological modelling of the catchment was carried out using MapWindow Soil and Water Assessment Tool to determine the annual gross and recoverable hydrokinetic potential of the water resource from the river. A Savonius hydrokinetic turbine system was developed and tested on the river. The mean voltage output at selected streamflow depths were determined to derive a power curve. Results showed that retrofitting the irrigation pumping system with an array of twenty units (20) of selected submersible irrigation pumps powered by twenty-two (22) units of an array of Savonius hydrokinetic turbines would satisfactorily deliver irrigation water into night storage and irrigate the pilot field of 100 ha of farmland on plot 2 and 5 on the scheme.

Keywords: Hydrokinetic, Savonius, Turbine, Irrigation, Pump, Retrofit

1.0 INTRODUCTION

Irrigation may be defined as a process of supplying water to crops by artificial means (Modi, 2014). High cost of irrigation water supply to irrigated farms has been a major problem on many irrigation schemes in the country. High cost of fossil fuel (diesel and petrol) and its use for irrigation pumping has led to inefficient irrigation in many schemes. Middle Ogun Irrigation project is a large irrigation scheme located in Iseyin town, Oyo State, southwestern Nigeria. This project is under the Ogun Oshun River Basin Development Authority (O-ORBDA). The project was originally conceived as a 12000-hectare irrigation project covering parts of the northern and southern areas in Oyo state. However, only 3000 hectares designated as phase 1 has been developed. The irrigation project is saddled with agricultural food production and all year farming using irrigation methods. The project was faced with the problem of high cost of operating the large irrigation pumping facilities on the scheme due to the use of petroleum diesel fuel. This problem of powering pumps for irrigation water pumping has consequently led to irrigation inefficiency on the scheme (Ogundare, 2021). Therefore, there is need to seek alternative ways of getting affordable energy for effective irrigation pumping on the scheme.

Hydrokinetic energy conversion technology involves the conversion of kinetic energy from streamflows in rivers, oceans and tidal currents to generate electricity (Armañanzas *et al.*, 2024). This type of energy conversion system abstracts the energy of streamflow or river and converts it to rotational energy using a turbine rotor. Rotational energy produced from the rotor is converted to electrical energy using a generator. This form of power generation portends less danger to the environment because it does not require building dams or head works and is a renewable energy source (Adarah *et al.*, 2022; Khan *et al.*, 2007; Khan *et al.*, 2009; Botto *et*

al.,2010).Hydrokinetic technology is able to generate electrical energy to supply households from middle to high discharge rivers (Tan *et.al.* 2017). Bancant and Wosnik (2011) also developed specialized hydrokinetic turbines which were used to power ocean instruments in Korea. Wamalwaet *al.* (2017) also studied how to retrofit a conventional hydropower plant with pump back system using hydrokinetic technology and was able to get energy yield in the resultant system by 39 to 41.48 %.

The use of this type of technology on the Middle Ogun irrigation river for irrigation pumping and retrofitting the irrigation system would alleviate the problem of power dearth presently being experienced on the irrigation scheme and improve the irrigation efficiency of the scheme. Therefore, this study aimed at the design of a hydrokinetic energy conversion system and retrofitting of the Middle Ogun scheme for more efficient irrigation water pumping.

2.0 MATERIALS AND METHODS

2.1 Study Area

This project is located at about fifteen kilometers from Iseyin town towards Oyo town in Oyo State, Nigeria. It lies between coordinates 875232.89 N, 578464.09 E and 871820.67 N, 576912.95 E. The Ogun River borders the north east area of the project downstream of Ikere Gorge Dam. Located on the river is a concrete weir and pump house constructed for irrigation purposes. Figure 1 shows the inset of the location of the project area on Nigeria map. The entire layout consists of four (4) parts. Area part one (1): which is along Olokemeji has 1386 ha suitable for irrigation farming; Area part two (2): is around Eleyele axis of the project area, it covers about 12000 ha; Area part three (3): is situated around Odo Ogun where the study was focused, it is about 1200 ha and Area part four (4): was originally planned has 1200 ha of farmland and recommended for development. It is located near Ikere Gorge Dam. Figure 2 shows the layout of the project and the four areas. This study focused mainly on Area part 3 presently developed for irrigation activities. Figure 3 (a) and (b) presents the layout for the plots 2 and 5. Plots 2 covers 600 ha while plot 5 covers 320 ha. A layout of 100 ha was selected as the pilot scheme out of the plots 2 and 5 as shown in Figure 4. The Ogun river borders the North East area of the Project downstream Ikere Gorge dam. The irrigation distribution system for plot 2 and 5 is pipe network. The main features of irrigation facilities were shown in Table 1.



Figure 4: Layout of Plot 2 and 5. Source:Konsadem Associates (2021)

Table 1: Main features of irrigation facilities

Description	Capacity
Headwork	70 m concrete ogee spillway,
Generator house with 5nos generator	1500 KVA each generator
Vertical pump Installations with total	8 nos, 900 Hp vertical pump
Ductile Iron Rising Mains diameter	14 km of 900/800/700 mm
Downstream release from Ikere Gorge	60 Mm ³
Sprinkler Irrigation Distribution System	3000 ha planned irrigation area
Service, Secondary and farm roads	152 km
Reinforce concrete bridge deck	70 m

Source: Ogun Oshun River Basin Development Authority (OORBDA, 2008)

2.2 Determination of Seasonal Irrigation Water Requirement

A pilot irrigation field of about 100 ha was selected at plot 2 and 5 of the scheme. Irrigation water requirement of crops was evaluated from the seasonal crop evapotranspiration and effective rainfall for selected crops using CROPWAT 8.0. CROPWAT 8.0 is a decision support tool for determining the irrigation requirements for crops grown on the scheme. The model gave the Crop Evapotranspiration (ET_c), Effective rainfall (Eff_{rain}) and Irrigation Requirements (IRR) of these crops. Crops grown on the scheme included Maize, Tomatoes, Soyabeans and Cabbage. Input parameters for CROPWAT 8.0 were determined on the field. Input parameters are average monthly weather record, effective rainfall, soil bulk density, soil moisture content, soil texture and soil infiltration rate of the selected irrigation field.

2.3 Determination of Delivery Head

The contour map in Figure 5 shows the distance and height of the Night Storage (NS), turbine and pumping point for retrofitting the irrigation pumping system. Contour map was plotted using the topographical survey of study area. Topographical survey was carried out to evaluate the volumetric capacity of night storage (V_{NS}), delivery head (H) and distance of the submersible pumps from the Pumping Point (PP). Survey was carried out using the total station (Nikon, NTS - 365). Data were taken between RES 1 (577083.142 E and 871759.59 N), RES 2 (577142.235 E and 871782.789), RES 3 (577051.301 E and 871853.712 N) and RES 4 (577051.301 and 871835 N). The pumping head from the submersible pumps on the reservoir to Night Storage (NS) was evaluated as shown in Figure 6.

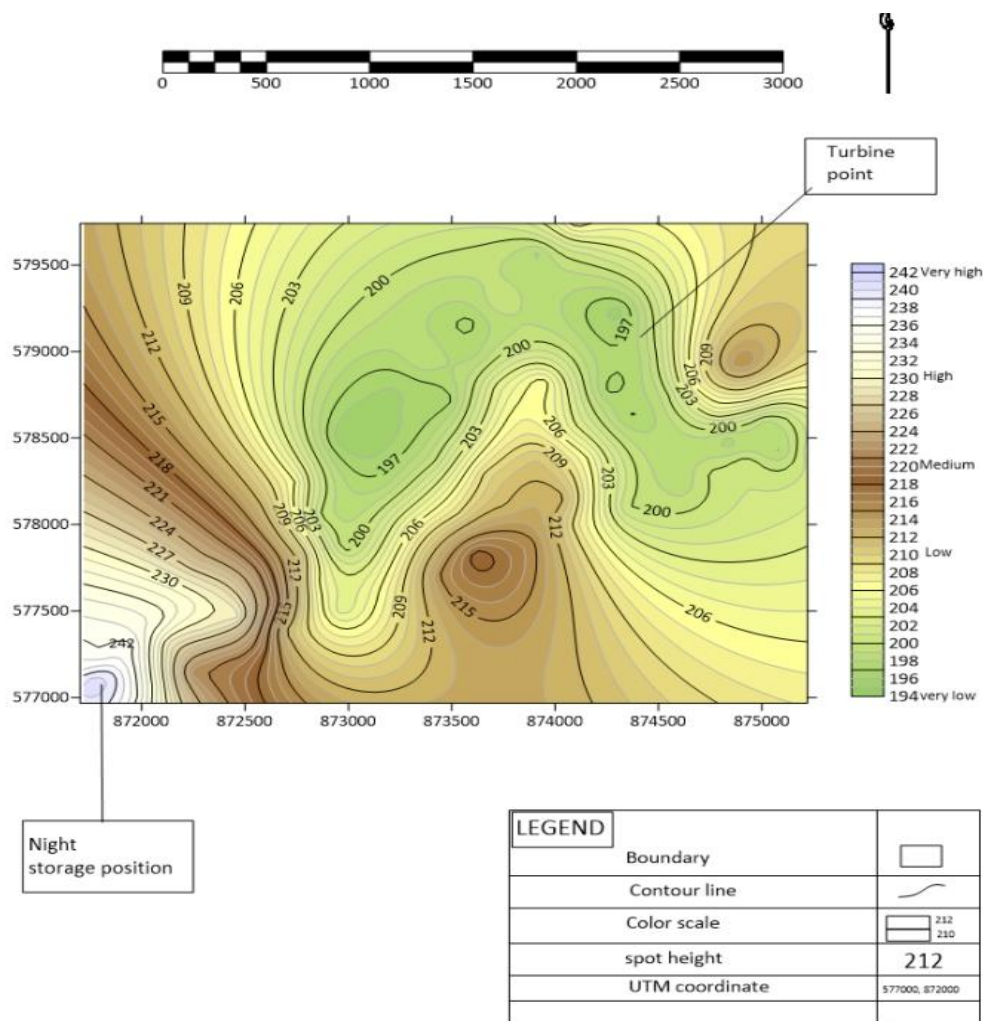

Figure 5: Contour map showing elevation of Night Storage and Turbine Point

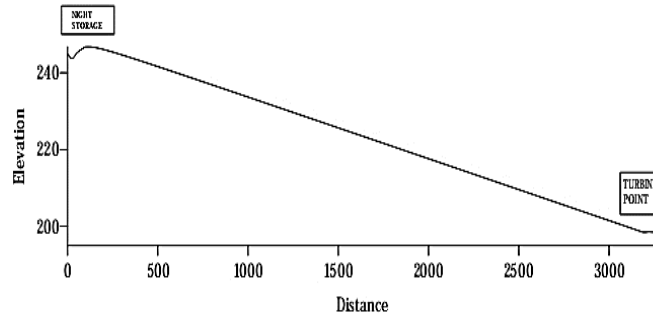

Figure 6: Evaluation of pumping head from reservoir

2.4 Determination of Pumping Discharge and Selection of Pumps

The delivery head was evaluated from the contour map. Discharge of the pumps were evaluated using equation 1 (Michael, 2009). Selection of submersible pumps were carried out using Lowara Xylem pump catalogue (2024) as shown in Figure 7.

$$Q = 27.78 \frac{Ay}{RT} 1$$

where: Q is discharge of pump (m³/s); A is area of land under crop (hectares); y is depth of irrigation (cm); R is rotation period (days); T is duration of pumping (hour/days).

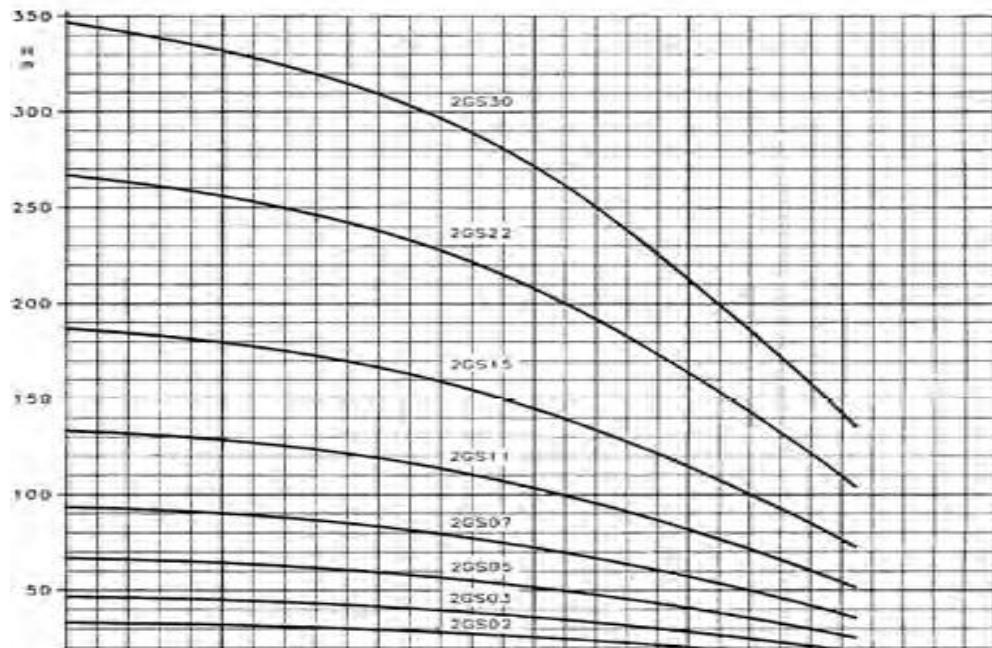

Figure 7: Lowara Xylem 2GS (2024) pump catalogue chart

2.5 Evaluation of Irrigation Pumping Parameters

Irrigation pumping parameters such as the number of irrigation pumping cycle, pumping hours and number of hydrokinetic turbine powering units required for pumping were evaluated using equations 2 – 4.

Irrigation pumping cycles

Number of pumping cycles required to satisfy the irrigation requirements was estimated using equation 2, given as

$$\text{No of pumping cycles} = \frac{\text{Total Seasonal Irrigation Requirements (mm)}}{\text{Volumetric capacity of Night Storage (m}^3\text{)}} \quad 2$$

Pumping hours per cycle to fill Night Storage

Number of pumping hour per cycle to fill night storage was estimated according to equation 3, given as

$$\text{Pumping hour per cycle} = \frac{\text{Volumetric capacity of the night storage (m}^3\text{)}}{\text{Total capacity of pumps (m}^3\text{/hr)}} \quad 3$$

Determination of turbine powering units

The number of hydrokinetic turbines required for powering the pumps per pumping cycle was estimated using equation 4, given as

$$\text{Number of turbine} = \frac{\text{power requirements of 20 units of pumps kW}}{\text{Power output per unit HKT}} \quad 4$$

2.6 Hydrological Modelling of the Catchment

Hydrological modelling of the catchment was carried out using the MapWindow Soil Water Assessment Tool (MWSWAT). MWSWAT was used to evaluate the gross and recoverably hydrokinetic power resource of the study area considering ten delineated sub basins. Table 2 shows the input data for the MWSWAT.

Table 2: Input data for MWSWAT modelling

S/N	Description	Resolution	Remark
1	Digital Elevation Model	90 × 90	Shuttle Radar Topographical Mission
2	Land use Classification	1km	Global Land Cover Classification Satellite Raster
3	Soil Types and Texture	10km	Digital Soil Map
4	Daily precipitation, max & min temp, Rel Humidity, Wind and Solar		Thirty-four years (Jan 1979- Dec 2013) weather record from WMO

Source: Neitsch *et al.* (2009)

Determination of surface runoff from the catchment

The Soil Conservation Service (SCS) curve number, Green and Ampt infiltration method were used to evaluate the surface flow using equations 5.

$$Q_{Surf} = \frac{(R_{day} - 0.2S)^2}{(R_{day} + 0.8S)} \quad 5$$

Where: Q_{Surf} is Runoff (mm); R_{day} is Rainfall depth/day (mm); S is retention (mm)

2.7 Gross and Recoverable Hydrokinetic Potential of Middle Ogun River

Gross theoretical hydrokinetic power resource (P_{th}) is the segment specific gross naturally available hydrokinetic resource. Gross and recoverably hydrokinetic power available were estimated using equations 6 and 7.

$$P_{th} = \gamma Q \Delta H \quad 6$$

Where: P_{th} is theoretically available hydrokinetic power (watts)

Q is the discharge (m^3/s)

ΔH is hydraulic head (m)

γ is the specific weight of water (N/m^3)

$$P_{rec} = \frac{1}{2} \rho A_s V^3 \quad 7$$

Where: P_{rec} is recoverable hydrokinetic power (watts)

ρ is density of water (kg/m^3)

A_s is swept area (m^2)

V is velocity of flow (m/s)

2.8 Design Parameters of the Developed Turbine

The design of Savonius turbine for power extraction considered the firm yield of the irrigation channel. Designed parameter for developed Savonius turbine were given as below.

Height of turbine rotor and Swept Area

Rotor height and Aspect Ratio are given by equations 8 and 9

$$H = 2D \quad 8$$

$$A_s = H \times D \quad 9$$

where: H is the height of rotor (m); D is diameter of rotor (m); A_s is swept area of rotor (m^2)

End plate diameter

End plate diameter was evaluated using equation 10

$$D_o = 1.25 \times D \quad 10$$

where: D_o is the end plate diameter (m); D is rotor diameter (m)

Stage height

Rotor stage height in double stage turbine was evaluated using equation 11

$$h = \frac{H - 3t}{2} \quad 11$$

where: t is thickness of end plates (m); h is stage height of rotor (m); thickness of endplates is 0.002m.

Aspect Ratio

Aspect Ratio (AR) is the ratio of height of rotor and diameter. The Aspect Ratio and stage Aspect Ratio were evaluated using Equations 12 and 13, respectively.

$$AR = \frac{H}{D} \quad 12$$

$$AR_{stage} = \frac{h}{D} \quad 13$$

where: AR is aspect ratio (dimensionless); AR_{stage} is stage aspect ratio (dimensionless)

Maximum thrust on turbine

The maximum thrust on Savonius turbine was evaluated using equation 14.

$$f = \frac{1}{2} \rho A_T v^2 \quad 14$$

where: f is maximum thrust (N); ρ is density of water (kg/m^3); A_T is velocity of flow (m/s); V is velocity of water flow (m/s)

Torque on Savonius rotor

Maximum torque on a turbine rotor occurs when maximum thrust was applied at the blade tip farthest from the axis. Maximum torque on a turbine rotor was evaluated using Equations 15- 18.

$$T_{max} = f_{max} * R \quad 15$$

$$f_{max} = \frac{1}{2} \rho A v^2 \quad 16$$

$$T_{max} = \frac{1}{2} \rho A v^2 R \quad 17$$

$$T = C_t T_{max} \quad 18$$

where: ρ is density of water (kg/m^3); A_s is swept area of rotor (m^2); V is velocity of water flow (m/s); R is blade radius (m); C_t is coefficient of thrust (dimensionless); f_{max} is maximum thrust on turbine (N); T_{max} is maximum torque on rotor (Nm); T is torque on rotor (Nm)

Power Abstracted from water flow

Power abstracted by the turbine was estimated using equation 19

$$P_{rec} = \frac{1}{2} \rho A_s V^2 \quad 19$$

Where A_s is the rotor swept area (m^2); V is velocity of water (m/s); ρ is the density of water (kg/m^3)

Shaft diameter

Shaft diameter was evaluated using equations 20

$$d_{\text{shaft}} = \left(\frac{32n_s}{\pi\sigma_y} \sqrt{M_b^2 + T^2} \right)^{1/3} \quad 20$$

Where: d_{shaft} is the diameter of the shaft (m); n_s is the factor of safety (dimensionless); σ_y is the yield strength of material (MPa); M_b is the bending moment on shaft (Nm); T is the torque transmitted by shaft (Nm);

Tip Speed Ratio

Tip Speed Ratio (TSR) of turbine is the ratio of velocity of rotor blade to the linear velocity of streamflow given by equation 21

$$\text{TSR} = \frac{\omega \times D}{V} \quad 21$$

Where TSR is the Tip speed ratio of turbine (dimensionless); ω is angular velocity of rotor (rad/sec); D is the diameter of the circular blade of rotor (m); V is the velocity of water (m/s).

Angular speed and power output

The power transmitted by the solid shaft was estimated using equations 22 and 23.

$$\omega = \frac{2\pi N}{60} \quad 22$$

$$P_T = T\omega \quad 23$$

Where ω is angular velocity of rotor (rad/sec); N is angular speed of shaft (rpm)

T is Torque on turbine rotor (Nm); P_T is turbine mechanical power output (watts). Table 3 shows the summary of the design parameters.

Table 3: Summary of the design parameters for the developed Savonius turbine

Parameter	Value
Rotor Diameter (D_{sav})	0.3 m
Rotor Height	0.6 m
Swept Area (A_s)	0.18 m ²
Diameter of End Plates (D_o)	0.38 m
Stage Height (h)	0.3 m
Stage Aspect Ratio (AR_{stage})	0.99
Thrust on shaft (T_{shaft})	260.1 N
Drag force on Shaft (M)	104 Nm
Hydrokinetic Power ($P_{\text{hydrokinetic}}$)	442.17 W
Torque transmitted by Shaft	19.56 Nm
Diameter of Shaft	0.02 m
Overlap Ratio	0.2
Shaft speed (RPM)	216.55 rpm
Tip Speed Ratio (TSR)	2
Blade Arc angle	124°

2.9 Fabrication of Turbine

Materials for fabrication of developed Savonius turbine were sourced locally in Saw Mill area of Ilorin. Fabrication was carried out at the Mechanical Metal Workshop of Lower Niger River Basin Development Authority, Ilorin. The developed Savonius turbine was tested on the Middle Ogun River. Power curve was derived as a graph of power output against stream flow. Front, Side, Plan, Exploded and Isometric views of developed turbine were shown in Figures 8-12

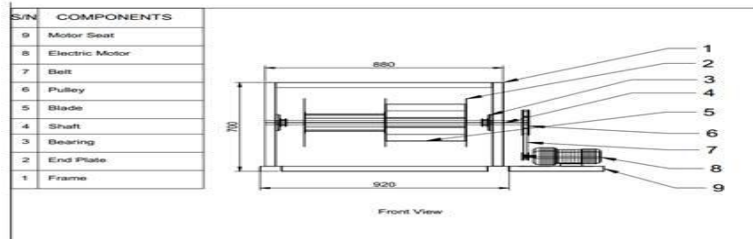

Figure 8: Orthographic diagram with front view of the turbine

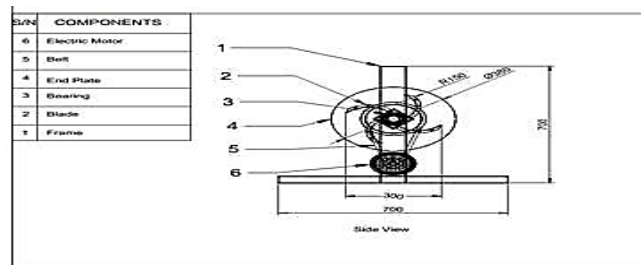

Figure 9: Orthographic diagram with side view of the turbine

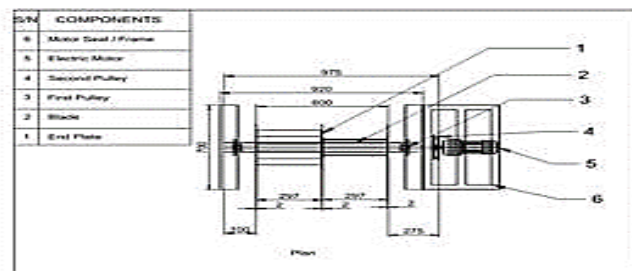

Figure 10: Plan view of the turbine

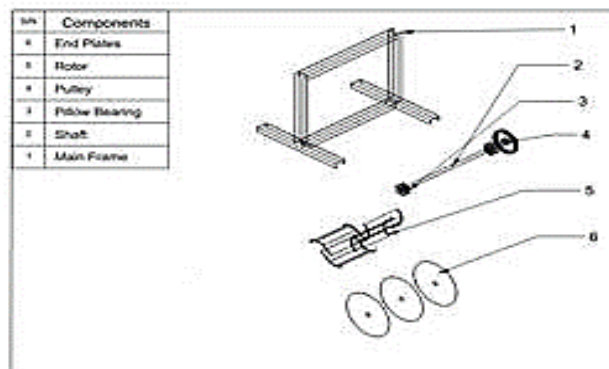

Figure 11: Exploded view of the turbine

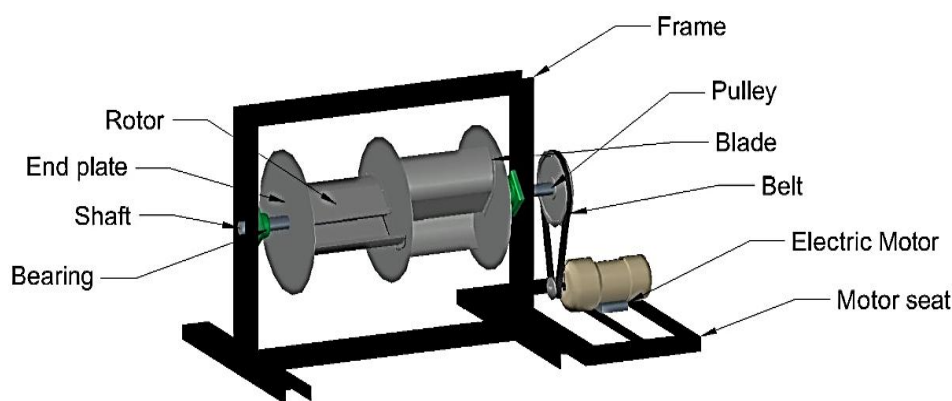

Figure 12: Isomeric view of Savonius turbine

3.0 Results and Discussion

3.1 Seasonal Irrigation Requirement

Table 4–7 shows the Crop Evapotranspiration (ET_c) and Irrigation Requirements (IRR) for crops grown on the pilot irrigation field of plot 2 and 5 of the scheme using CROPWAT 8.0. Considering about 100 ha of the pilot irrigation field for this study. ET_c of the major crops grown, including maize, soya beans, tomatoes and cabbage, were determined. ET_c varied between 9.0 – 49.50 mm/decade, 5.0 – 5.7 mm/decade, 9.30 – 58.60 mm/decade and 27.50 – 54.90 mm/decade for cultivated crops. IRR for each crop varied between 0.0 – 46.50 mm/decade, 0.0 – 59.70 mm/decade, 0.0 – 49.30 mm/decade and 0.0–54.60 mm/decade for Maize, Soyabeans, Tomato and Cabbage, respectively depending on the effective rainfall during the planting season. Table 8 shows the gross and net irrigation requirements on the pilot field as 648.90 mm and 428.46 mm respectively with irrigation efficiency of 69.0%.

Table 4: Maize seasonal evapotranspiration and Irrigation requirement

Month	Decade	Stage	K_c Coefficient	ET_c mm/day	ET_c mm/dec	Eff_{rain} mm/dec	Irr. Req. mm/dec
Sep	3	Init	0.30	1.47	14.7	35.6	0.0
Oct	1	Deve	0.41	2.00	20.0	22.6	0.0
Oct	2	Deve	0.65	3.19	31.9	12.6	19.3
Oct	3	Deve	0.91	4.21	46.3	9.3	37.0
Nov	1	Mid	1.12	4.95	49.5	5.8	43.7
Nov	2	Mid	1.15	4.78	47.8	1.3	46.5
Nov	3	Mid	1.15	4.68	46.8	1.0	45.9
Dec	1	Mid	1.15	4.59	45.9	0.7	45.1
Dec	2	Late	1.11	4.36	43.6	0.0	43.6
Dec	3	Late	0.90	3.69	40.5	0.1	40.4
Jan	1	Late	0.66	2.84	28.4	0.3	28.1
Jan	2	Late	0.50	2.25	9.0	0.1	8.9
					437.6	130.8	358.4

Table 5: Soyabeans seasonal evapotranspiration and Irrigation requirement

Month	Decade	Stage	Kc Coefficient	Etc mm/day	ETc mm/dec	Eff rain mm/dec	Irr. Req. mm/dec
Sep	3	Init	0.50	2.45	19.6	28.5	0.0
Oct	1	Deve	0.53	2.58	25.8	22.6	3.2
Oct	2	Deve	0.87	4.25	42.5	12.6	29.9
Oct	3	Mid	1.15	5.33	58.6	9.3	49.3
Nov	1	Mid	1.15	5.07	50.7	5.8	44.9
Nov	2	Mid	1.15	4.79	47.9	1.3	46.6
Nov	3	Mid	1.15	4.69	46.9	1.0	46.0
Dec	1	Late	0.95	3.81	38.1	0.7	37.4
Dec	2	Late	0.61	2.38	14.3	0.0	14.3
					344.4	81.8	271.4

Table 6: Tomato seasonal evapotranspiration and Irrigation requirement

Month	Decade	Stage	Kc Coefficient	Etc mm/day	Etc mm/dec	Eff rain mm/dec	Irr. Req. mm/dec
Sep	3	Init	0.60	2.94	23.5	28.5	0.0
Oct	1	Init	0.60	2.94	29.4	22.6	6.8
Oct	2	Init	0.60	2.94	29.4	12.6	16.7
Oct	3	Deve	0.61	2.84	31.2	9.3	21.9
Nov	1	Deve	0.71	3.14	31.4	5.8	25.6
Nov	2	Deve	0.83	3.46	34.6	1.3	33.2
Nov	3	Deve	0.95	3.87	38.7	1.0	37.7
Dec	1	Deve	1.07	4.26	42.6	0.7	41.9
Dec	2	Mid	1.13	4.42	44.2	0.0	44.2
Dec	3	Mid	1.13	4.64	51.0	0.1	50.9
Jan	1	Mid	1.13	4.85	48.5	0.3	48.2
Jan	2	Mid	1.13	5.06	50.6	0.3	50.3
Jan	3	Mid	1.13	5.37	59.1	0.3	58.8
Feb	1	Mid	1.13	5.67	56.7	0.1	56.7
Feb	2	Late	1.13	5.97	59.7	0.0	59.7
Feb	3	Late	1.07	5.95	47.6	0.8	46.8
Mar	1	Late	0.97	5.66	56.6	5.4	51.3
Mar	2	Late	0.85	5.24	52.4	7.9	44.5
Mar	3	Late	0.79	4.99	5.0	0.9	5.0
					792.3	97.8	700.3

Table 7: Cabbage seasonal evapotranspiration and Irrigation requirement

Month	Decade	Stage	Kc	Etc	ETc	Eff rain	Irr. Req.
			Coefficient	mm/day	mm/dec	mm/dec	mm/dec
Sep	3	Init	0.70	3.43	27.5	28.5	0.0
Oct	1	Init	0.70	3.43	34.3	22.6	11.7
Oct	2	Init	0.70	3.43	34.3	12.6	21.6
Oct	3	Init	0.70	3.26	35.8	9.3	26.5
Nov	1	Deve	0.73	3.20	32.0	5.8	26.2
Nov	2	Deve	0.78	3.27	32.7	1.3	31.4
Nov	3	Deve	0.84	3.44	34.4	1.0	33.4
Dec	1	Deve	0.90	3.60	36.0	0.7	35.3
Dec	2	Deve	0.96	3.75	37.5	0.0	37.5
Dec	3	Deve	1.02	4.19	46.0	0.1	45.9
Jan	1	Mid	1.05	4.50	45.0	0.3	44.8
Jan	2	Mid	1.05	4.70	47.0	0.3	46.7
Jan	3	Mid	1.05	4.99	54.9	0.3	54.6
Feb	1	Mid	1.05	5.27	52.7	0.1	52.7
Feb	2	Late	1.05	5.55	55.5	0.0	55.5
Feb	3	Late	1.01	5.65	45.2	0.8	44.4
Mar	1	Late	0.97	5.67	34.0	3.2	31.3
					684.9	86.8	599.6

Table 8: Seasonal Irrigation Water Requirements

Parameters	Value
Gross Irrigation Requirement (GIR)	645.90 mm
Net Irrigation Requirement (NIR)	428.46 mm
Irrigation Efficiency (IE)	69.0%

3.2 Annual gross and recoverable hydrokinetic power resource

Tables 9 shows that hydraulic slope of the subbasin varied between 0.001894 and 0.004933 while the hydraulic head varied between 5.48647 and 26.7693m. SWAT simulations indicated subbasin in the catchment with different land use or soils having remarkable effect on the hydrology of the catchment. The mean annual flows from the catchment varied between 98.33 and 1214m³/s within sub-basins 35 – 44. Tables 10 shows the estimated annual gross hydrokinetic power (HKP) from the water resource is 1003.70MW. Recoverable Factor (PF) for power generations was 0.0035 and annual recoverable HKP was evaluated as 4.01MW.

Table 9: Geometry and hydraulic head (m) of sub-basins

Sub-basin	Order	Length (m)	Slope	Adjacent Straight L (m)	Hydraulic Head ΔH (m)
35	1	2781.90	0.0021568	2543.8	5.48647
36	1	2835.50	0.002468	2330.6	5.75192
37	1	5260.30	0.003231	4610.6	14.8949
38	1	34673.30	0.0029129	26732.6	77.8694
39	1	6789.20	0.0033877	6153.2	20.8452
40	1	7720.40	0.004274	6263.3	26.7693
41	1	5108.60	0.004893	4094.4	20.0339
42	1	14483.50	0.004933	12132.6	23.4523
43	1	5266.80	0.002848	4395.6	12.5170
44	1	4221.80	0.001894	3941.1	7.4680

Table 10: Annual gross and recoverable hydrokinetic power

Sub-basin	Hydraulic Head ΔH (m)	Mean Annual Flow Q (m^3/s)	Specific Weight of Water γ (Nm^{-3})	Mean Annual Gross HKP (P_{th}) $\times 10^6$ Watts	Mean annual recoverable HKP (P_{rec}) $\times 10^6$ Watts
35	5.48647	191.564	9800	10.3	0.04
36	5.75192	510.9230	9800	28.8	0.12
37	14.8949	600.80	9800	87.7	0.35
38	77.8694	169.04	9800	129.0	0.52
39	20.8452	1214.00	9800	248.6	0.99
40	26.7693	947.7088	9800	265.7	1.06
41	20.0339	657.4232	9800	108.4	0.43
42	23.4523	98.33	9800	22.6	0.09
43	12.5170	184.2392	9800	92.3	0.37
44	7.4680	140.7368	9800	10.3	0.04
				1003.70 MW	4.01 MW

3.3 Power Curve

Figure 13 shows the power curve for developed Savonius turbine. It shows the power output against flow velocity of streamflow. Results showed that stream velocities of between 0.32 – 0.5 m/s gave zero power output. Cut in speed of 0.564 m/s of flow was attained with power output of 0.18 W. Average streamflow speed of 1-2 m/s gave 0.3 kW. The exponential curve showed that optimal speed of 4 m/s would produce power output of 1.1 kW using the turbine of 0.18 m² swept area.

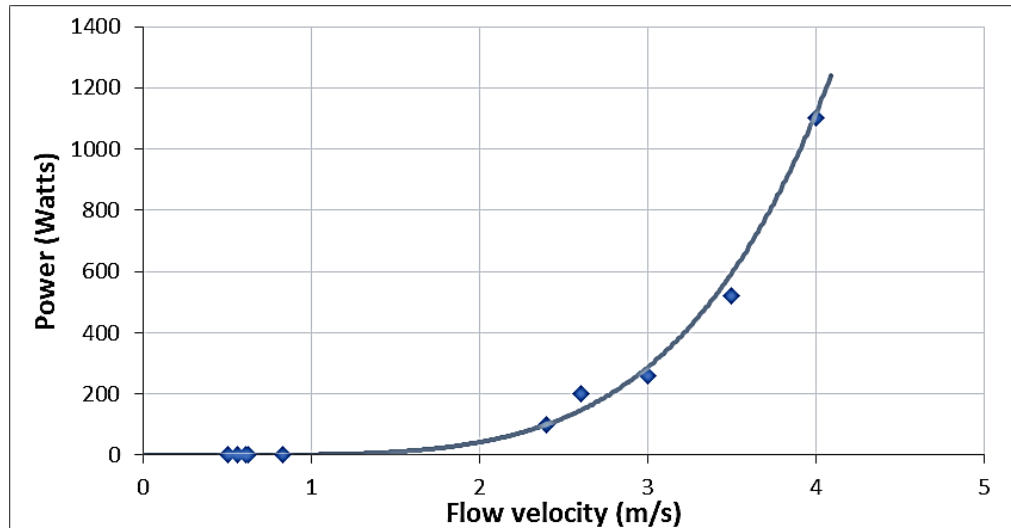

Figure 13: The Savonius hydrokinetic power curve

Findings from this study showed that the mean annual gross and recoverable hydrokinetic power potential of the irrigation river as 1004 MW and 4.01 MW, respectively. This is significant to power output for irrigation pumping. Power curve gave an exponential streamflow velocity of 3 m/s as power output and turbine swept area of 9.6 kW and 1.8 m² turbine swept area. The turbine showed a satisfactory performance of evaluation for TSR and C_p as 1.00 and 19.1 % respectively. Retrofit of twenty (20) units of selected pumps powered by twenty-two (22) units of Savonius hydrokinetic turbines would satisfactorily deliver irrigation water to pilot irrigation scheme and in essence improve irrigation efficiency.

3.4 Retrofitting parameters

Table 11 shows the retrofitting parameters for irrigation pumping system. Retrofitting of the irrigation pumping and Hydrokinetic Turbine powering units was done by estimating the required pumping and hydrokinetic turbine units from the Lowara Xylem brand pump catalogue and the developed power curve, respectively. Results showed that retrofitting the irrigation pumping system with an array of twenty units (20) of selected submersible irrigation pumps powered by twenty-two (22) units of an array of Savonius hydrokinetic turbines would satisfactorily deliver irrigation water into night storage and irrigate the pilot field of 100 ha of farmland on plot 2 and 5 on the scheme.

Table 11: Retrofitting parameters

Parameters	Values
Pumping discharge	21m ³ /s
Delivery head (H)	44.62m
Power requirements per unit pump	2.20kW
Total Power requirements	44kW
Number of pumping units	20 units
Total discharge capacity of pumps	420m ³ /hr
Power output per unit turbine	1.1kW
Number of hydrokinetic turbine units	40 units
Total Power output of HKT	4.4kW
Number of pumping cycle	12.56 / season
Pumping hours per cycle	81.20hrs

3.5 Cost Analysis

Table 12 presents the cost analysis of utilizing the. diesel fossil fuel as power source for irrigation pumping and the estimated costs of retrofitting of retrofitting irrigation system using Twenty-two (22) units of hydrokinetic turbines. It can be clearly observed that the costs of using the fossil fuel is 114 % more than the cost incurred when using the renewable energy source for powering the irrigation pumping system.

Table 12: Cost analysis before and after retrofitting for irrigation pumping

S/N	Activity	Cost before Retrofitting (Using A.G.O. based Generator)	Cost after Retrofitting (Using 22 units of Hydrokinetic Turbines)
1	Procurement of (44kW) power source for irrigation pumping	₦ 5,314,310.00	₦ 4,536,684.79
2	Installation of power source for irrigation pumping	₦ 500,000	₦ 350,000
3	Running of power source for 1 day (24 hours)	₦ 439,369.2 (est. 11.1811/h at ₦1550/l)	₦1,200
4	Running of power source for 30 days	₦ 13,181,076	₦ 36,000
5	Running of power source for 365 days (1 year)	₦ 160,369,758	₦ 438,000
6	Running of power source for 5 years	₦ 801,848,790	₦ 2,190,000
7	Estimated cost of 44kW	₦ 806,855,100	₦ 7,076,684.79

4.0 Conclusion

A double-stage Savonius hydrokinetic turbine that could be able to power selected irrigation pumps was developed. The mean annual gross hydrokinetic power potential obtained was 1003.70 MW and the mean annual recoverable hydrokinetic power resource was 4.01 MW. This is sufficient to power the selected pumps for irrigation water delivery.

Also, seasonal net irrigation requirement for the selected crops in this study was 428,460 m³. This can be efficiently delivered through the twenty (20) retrofitted pumping units, powered by twenty-two (22) units of Savonius hydrokinetic turbines. This would satisfactorily deliver irrigation water to the pilot scheme. It would also provide a viable alternative to the diesel powered water delivery pumping system presently used at the pumping station.

REFERENCES

- Adarsh G., Sujeet K., Sakshi S., Gaurav D., Gaurav S., Anuj K., Kamaraj N. (2022) Application of alternative clean energy, Editor(s): Krishna K., Ram S.R., Omprakash K., M. Shamim K., Sanjeevikumar P., Sustainable Developments by Artificial Intelligence and Machine Learning for Renewable Energies, Elsevier, pp1-2
- Armañanzas, J. & Alcalá, M. & Fuertes, J. & Leon, J. & Torres, A. & Gil, M. (2024). Design and Experimentation of a Hydrokinetic Turbine for Electricity Generation in Closed Pipes. WSEAS TRANSACTIONS ON FLUID MECHANICS. 19. 64-71. 10.37394/232013.2024.19.7.
- Banchant P. and Wosnik M. (2011) Experimental Investigation of Helical Cross Flow Axis Hydrokinetic Turbines Including Effects of Waves and Turbulence, Proceedings of ASME.J, SME-KSME Joint Fluid Engineering Conference, Shizuoka, JAPAN
- Botto A., Claps P. Ganora D., Laio F., (2010), Regional Scale Assessment of Energy Potential from Hydro Kinetic Turbine used in Irrigation Channels, Conference Proceedings, Bari, Italy 1 – 5
- Federal Survey, Abuja (1995) Federal Department of Survey, Abuja, Nigeria. Topo sheet 241 OYO North West.
- Howard, S. (2013) World Bank Turns to Hydropower to Square Development with Climatic Change. The Washington Post, pp. 3-6.
- Khan M.J., Iqbal M.T. and Quaicoe J.E., (2007) “River Current Energy Conversion Systems: Progress, Prospects and Challenges”, Renewable and Sustainable Energy Reviews, pp 177 – 193.
- Khan M. J., Bhuyan G., Iqbal M. T. and Quaicoe J. E., (2009) “Hydrokinetic Energy Conversion Systems and Assessment of Horizontal and Vertical Axis Turbines

- for River and Tidal Applications: A Technology Status Review”, Applied Energy, pp 182 – 183.
- Lowara Xylem (2024) Pump Selection Guide (Residential and commercial water), hydraulic pump catalogue retrieve on the 3rd of January 2024 from <https://www.xylem.com>
- Michael A.M. (2009), Irrigation Theory and Practice, second Edition, Uikes Publishing HomePVT Ltd pp. 4.
- Modi P.N. (2014) Irrigation Water Resources and Water Power Engineering, Rajsons Publication PVT Ltd Nineth Edition pp.107 – 109
- Neitsch S.L, Annold J.G., Keiniry J.R., and Wiliam J.R., (2009) Soil and Water Assessment Tool Theoretical Documentation. Grassland, Soil and Water Research Laboratory, Agricultural Research Service 508 East Black land Road, Temple, Texas 76502
- Ogundare, G. (2021) How Failed Water Projects Worsen Food Insecurity In Southwest Nigeria, International Centre for Investigative Reporting, retrieved from <https://www.icirnigeria.org/how-failed-water-projects-worsen-food-insecurity-in-southwest-nigeria/>
- OORBDA, (2018), Brief on Middle Ogun Irrigation Project and Operational Design
- Tan K.W., KirkeB. and Anyi M. (2011) Experimental Investigation of Helical Cross -Flow Axis Hydrokinetic Turbine, Including Effects of Waves and Turbulence, Proceedings of ASME-J, SME-KSME Joint Fluids Engineering Conference, Shizuoka, Japan.
- Wamalwa F., Sichilalu S and Xia X.(2017) Optimal Control of Hydrokinetic Powered Pump Back System for a Hydropower Plant in Dry Season: A Case Study Energy Procedia, 8th International Conference on Applied Energy – ICAE 2016. Vol.105, pp 94-101.