

Correlation between EMF and Gibbs free energy, and the relative concentration of electrolytes in a Concentration Cell

Abstract

The experiment aimed at establishing a link between the varying concentration of the electrolyte in one half-cell of a concentration cell and the resulting EMF generated across the cell. Further, it also drew a connection between this variation and the change in Gibbs free energy for the electrochemical reaction. The change in Gibbs free energy calculated for the electrochemical reaction for each C_2 value indicated a decreasing trend with an increasing C_2 concentration. It was thus observed that as C_2 increased, or the difference in concentrations of the two electrolytes decreased, the spontaneity of the reaction decreased. Reduction occurs at the negatively charged cathode and oxidation occurs at the positively charged anode. Here, aqueous NaCl is undergoing electrolysis – where the Cl^- ions are attracted to the positive anode and get oxidized due to the loss of electrons and emerge as chlorine Cl_2 gas.

Keywords: Electrolysis, Voltaic cell, oxidation, electromotive force

INTRODUCTION AND BACKGROUND INFORMATION

Electrolysis is a very common industrial process applied in the electroplating of precious metals as well as refinement processes. It is said to occur when a non-spontaneous reaction is made spontaneous by the supply of electricity. By “non-spontaneous” we mean that the reaction cannot move to completion without the addition of external energy. An instrument used to carry out this process is called an **Electrolytic cell** as shown in Fig(1).¹

Such a cell converts electrical energy to chemical energy. The two electrodes – generally inert – are called the cathode and the anode. **Reduction** occurs at the **negatively charged cathode** and **oxidation** occurs at the **positively charged anode**. Here, aqueous NaCl is undergoing electrolysis – where the Cl^- ions are attracted to the positive anode and get oxidized due to the loss of electrons and emerge as chlorine Cl_2 gas. Similarly, the H^+ ions are reduced at the cathode **due to the gain of** electrons – getting discharged as H_2 gas. Therefore, the electrons supplied by

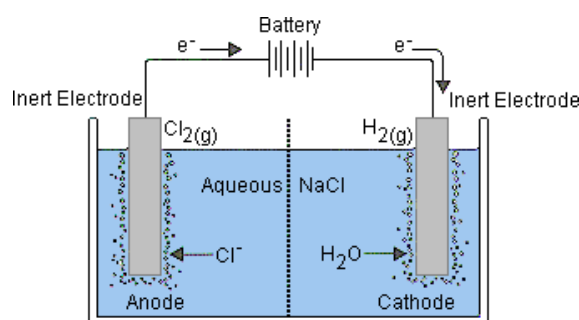

Figure 1: Electrolytic Cell

the external battery enter the cell through the cathode and leave through the anode. Often in processes like electroplating, the electrodes themselves are made of materials which are involved in the electrolysis, for example, silver (Ag) or copper (Cu).

Another type of cell is what we call a **Voltaic cell** or **Electrochemical cell**. These cells involve spontaneous reactions and convert chemical energy to electrical energy. Unlike electrolytic cells, the two electrodes are placed in separate electrolytes – with each container and its setup being called a **half-cell**.² The two containers are connected by a **salt bridge**. True to the definition of the two

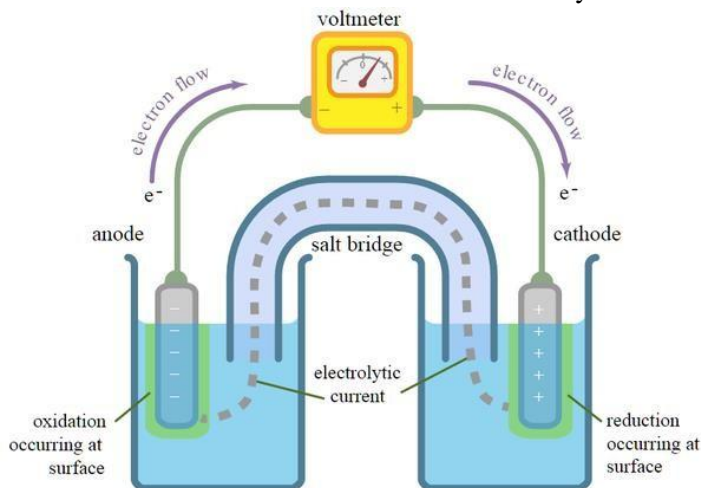

Figure 2: An Electrochemical cell

electrodes, oxidation and reduction occur at the anode and cathode. **However, the anode is negatively charged while the cathode is positively charged.** The electrodes are usually two metals placed in electrolytes of a corresponding salt. For example, Cu-electrode is placed in a CuSO_4 solution. Based on the electronegativity difference between the two metals, one of the metals gets oxidized while the other gets reduced. The more reactive metal is placed at the anode where it loses electrons and joins **of the electrolyte** as a positive ion. The opposite occurs at the cathode where the less reactive metal gains electrons and gets added on to the cathode from the electrolyte. Due to these redox reactions, different moles of electrons are present at the two electrodes – giving rise to a potential difference. This potential difference – called the **EMF** or **electromotive force** of the cell which can be measured using a voltmeter as shown in Fig (2) – produces a current

¹ Electrochemistry: Electrolytic Cells. (n.d.). Retrieved from <http://chemed.chem.purdue.edu/genchem/topicreview/bp/ch20/faraday.php>

The Bodner Group, Division of Chemistry Education, Purdue University West Lafayette, Indiana 47907-1393

² Chieng, C. (2018). *Half Cell Reactions*. [online] Science.uwaterloo.ca. Available at: <http://www.science.uwaterloo.ca/~cchieh/cact/c123/halfcell.html>.

through the flow of electrons who flow from the anode(-) to the cathode(+) through the external circuit. The salt bridge is essential as it helps to maintain the electrical neutrality of the two half-cells through a flow of charged ions. Salt bridges often use compounds like KNO_3 . Oxidation **at the anode** and reduction **at the cathode produces positively** and negatively charged ions respectively. The flow of electrons through the external circuit cause a charge to develop in the contents of the vessels. To **maintain neutrality**, anions in the salt bridge migrate into the anodic half-cell while the cations migrate to the cathodic side. This works to maintain the electro-neutrality – allowing the reaction to continue.³

Interested in majoring **in Instrumental and Control Engineering**, I have always been curious about the **working of the different lab equipment** I use as a science student. And it was while working on a Titration experiment in my chemistry lab that I was introduced to the **modern pH probe** which helped discover yet another alternate form of the electrochemical cell described above – a **Concentration cell**.

There are two types:

List 1: Concentration Cell and their description

Type of Concentration Cell	Description
Electrode Concentration Cell	Two electrodes of the same material but at different concentration dipped in the same electrolyte
Electrolyte Concentration Cell	Identical electrodes dipped in the same electrolyte but of different concentrations ⁴

In an electrode concentration cell, the potential difference is developed between the two electrodes which could be at different pressures, for example, hydrogen electrodes in the same H^+ ion solution. On the other hand, in an electrolyte **concentration cell, the potential difference arises due to the tendency of the electrolyte to diffuse from the higher to lower concentration** solution. The pH probe works on similar lines to this second type of concentration cell. H^+ ions from the reference solution and the tested chemical replace metallic ions on the electrodes in the dipped probe. Based on different degrees of acidity, the relative concentration of H^+ ions will vary and **as a result, different** amounts of electrical charge would develop on the electrodes. The voltage **measured will indicate this relative concentration** and the pH will be measured based on this.⁵

The cell potential measured at standard conditions (1 mol dm^{-3} concentration for reactants in solution and 100 kPa for gaseous reactants) for a concentration cell can be related to the electron energy differences of the oxidation and reduction reactions as follows:

$$E^\circ (\text{cell}) = E^\circ_{1/2} (\text{reduction}) - E^\circ_{1/2} (\text{oxidation}) = E^\circ_{1/2} (\text{cathode}) - E^\circ_{1/2} (\text{anode})^6$$

Here, $E^\circ_{1/2}$ (reduction) represents the standard reduction half-potential of the reduction reaction at the cathode while $E^\circ_{1/2}$ (oxidation) represents the reduction half-potential of the oxidation reaction

³ Chemistry.stackexchange.com. (2018). Why is it important to use a salt bridge in a voltaic cell? Can a wire be used?[online] Available at: <https://chemistry.stackexchange.com/questions/5477/why-is-it-important-to-use-a-salt-bridge-in-a-voltaic-cell-can-a-wire-be-used>

⁴ Askiitians.com. (2018). Concentration Cell - Study Material for IIT JEE | askIITians. [online] Available at: <http://www.askiitians.com/iit-jee-chemistry/physical-chemistry/concentration-cell.aspx>

⁵ Explain that Stuff. (2018). How do pH meters work? | Measuring acidity. [online] Available at: <http://www.explainthatstuff.com/how-ph-meters-work.html>

⁶ Webassign.net. (2018). Lab 13 - Electrochemistry and the Nernst Equation. [online] Available at: http://www.webassign.net/labsgraceperiod/ucscgencheml1/lab_13/manual.html

occurring at the anode. Further, the voltage produced by the cell can be calculated using the **Nernst Equation**.

$$E(\text{cell}) = E^\circ(\text{cell}) - \left(\frac{RT}{nF}\right) \ln Q$$

List 2 List of symbols and variables

SYMBOL	VARIABLE
E (cell)	Cell potential under non-standard conditions (V)
E° (cell)	Standard cell potential (V)
R	Gas constant = 8.31 (J mol ⁻¹ K ⁻¹)
T	Temperature (K)
n	Number of moles of electrons exchanged in electrochemical reaction
F	Faraday's Constant = 9.65 × 10 ⁴ C mol ⁻¹
Q	Reaction quotient, which is the equilibrium expression but with initial concentrations instead of equilibrium concentrations ⁷

This equation can be rewritten when the temperature **T = 25°C** and using the fact that

$$\ln x = 2.303 \times \log_{10} x$$

We can write

$$E = E^\circ - \frac{(0.0591 \text{ volts})}{n} \log_{10} Q$$

This form of the Nernst equation holds true for all cells at **25°C**. Further, we can also relate the EMF of the cell with the change in Gibbs free energy as

$$\Delta G = -nFE$$

The Nernst equation thus can be used to identify a relation between the relative concentration of the two half-cells and the EMF as well as the **ΔG** value. I thus formulated the following research question.

RESEARCH QUESTION

How does the relative concentration of the CuSO₄ electrolytes in the two half-cells of an Electrolyte Concentration cell affect the resulting EMF and change in Gibbs free energy produced?

⁷ ThoughtCo. (2018). What the Nernst Equation Is and How to Use It. [online] Available at: <https://www.thoughtco.com/nernst-equation-electrochemistry-equations-606454>

APPARATUS

- Two Reddish-brown Copper Electrodes
- KNO_3 Salt-Bridge
- Two 200 ml beaker
- Pipette
- Voltmeter and Connecting Wires
- **Reagents:** CuSO_4 solutions of the following concentrations:

0.5 M	0.5×10^{-1} M	0.5×10^{-2} M	0.5×10^{-3} M	0.5×10^{-4} M
-------	------------------------	------------------------	------------------------	------------------------

PROCEDURE

- Take 0.5M CuSO_4 solution and pour in one 200 ml beaker till the 150 ml mark. This should be marked as Concentration C_1 .
- Attach two wires to the voltmeter and clip them onto the two electrodes.
- Bring the two beakers near enough to balance the U-shaped KNO_3 salt-bridge such that it is immersed well below the surface of the electrolyte in both beakers.
- Using more than 0.5M CuSO_4 solution, make the solutions of lower concentrations by a ratio of 1:10. Use a pipette for ensuring accuracy.
- Fill the second beaker with the 150 ml mark with the 0.5 M solution – marked as concentration C_2 .
- With the voltmeter turned on, dip the two electrodes in each beaker such that more than half of the electrodes are immersed and take the initial reading in the voltmeter.
- Perform four trials for this concentration of C_2 and then use the consecutive CuSO_4 solution in the second beaker as an electrolyte – descending the concentration of C_2 from 0.5M to 0.00005M. Conduct four trials for each C_2 concentration.

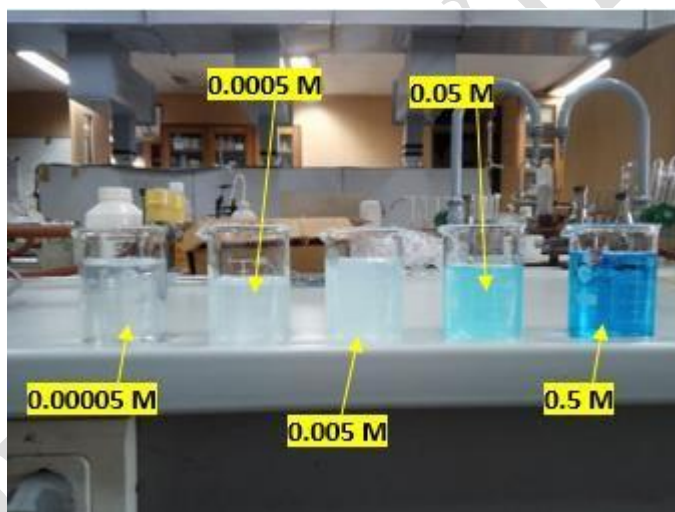

Figure 3: Observable fading of blue colour due to dilution of 0.5M CuSO_4 solution to make lower concentrations

Ensure that the electrodes are placed vertically and solution-level after immersion is constant for each trial to ensure that the same surface area of the electrode is exposed to the electrolyte. This is essential because it limits the impact of changing surface area which could change the rate of the redox reactions.

While taking trials, if the readings begin to vary greatly, it would be useful to refresh the solutions in the half-cells – although the ions getting exhausted at this scale would be unlikely. Another useful practice is to regularly scrape the electrodes between trials – cleansing and drying them.

However, make sure not to use new electrodes because that could impact the mass, thickness and surface area exposed to the electrolytes – possibly increasing random error due to reduced precision of data collected.

EXPERIMENTAL SETUP

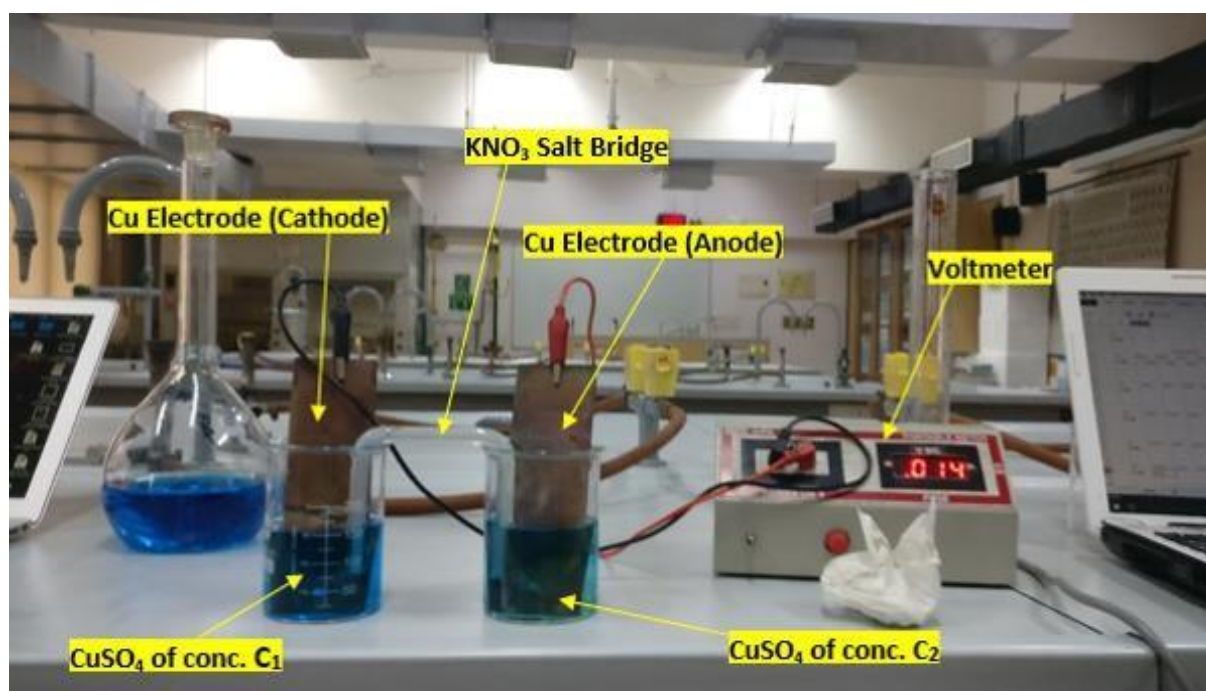

Figure 4: Working experimental setup

Fig (4) (above) displays the concentration cell created for the experiment. Opposed to the conventional setup where the cathode is on the right, the figure above shows the anode to be on the right. The electrode which is placed in the half-cell where the concentration of the electrolyte is C_1 (0.5M) becomes the positive cathode and the electrode in the beaker containing the varying C_2 forms the negative anode. This is based on the working of the concentration cell.

As explained earlier, the electrolyte concentration cell produces an EMF due to the tendency of the concentrations of the two electrolytes to equilibrate. CuSO_4 solution with concentration C_1 will have a higher concentration of Cu^{2+} ions than the C_2 concentration electrolyte. (Except when $C_2 = 0.5\text{M}$)

Connected by the salt-bridge which doesn't allow ions to intermix from one half-cell to another, the solutions will try to achieve similar concentrations through redox reactions. In the C_1 beaker, the Cu^{2+} ions will reduce themselves at the electrode by gaining electrons and therefore decreasing their concentration in the solution. In the other half-cell, the copper atoms in the electrode will oxidize themselves by losing electrons and increasing the Cu^{2+} ion concentration in the electrolyte. These electrons will flow through the external circuit to the cathode and the redox cycle will continue until a concentration equilibrium isn't achieved. Therefore, the electrode immersed in the electrolyte with concentration C_1 witnessed reduction – therefore is the cathode – while oxidation occurs at the other electrode – making it the anode.

Reduction equation at Cathode:

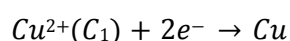

Oxidation equation at Anode:

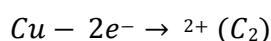

SAFETY AND ETHICAL CONSIDERATIONS

- A limited amount of CuSO_4 should be used and the consequent concentrations should be produced using the same 0.5M solution that was used in the first round of trials.
- It is essential for the accuracy of data collection as well as the protection of the experimenter for the concentrations to be taken accurately. Higher concentrations may be irritants to the skin.
- Based on the Material Safety Data Sheet⁸ for $\text{CuSO}_4 \cdot 5\text{H}_2\text{O}$, CuSO_4 solutions can be harmful to the cornea and therefore usage of eyewear like goggles is essential while handling the chemical. Further, the chemical should be kept away from the mouth and nose too.
- While disposing of waste, ensure that chemicals are poured into the sink with excess water. All glassware should be washed using soap, followed by rinsing in tap water and deionized water if available.⁹
- Electrical components like the voltmeter must be handled with care and with dry hands.

VARIABLES

- **Independent Variable** – Concentration (C_1/M and C_2/M) of the electrolytes in the two half-cells. These were prepared as explained in the procedure and were thus controlled by the experimenter. These together constitute Q – the equation quotient.
- **Independent Variable** – Temperature (K) of the cell. This is maintained at room temperature – roughly 24.6°C . This introduces an assumption made to simplify calculations in the following data processing: the room temperature is assumed to be 25°C .
- **Dependent Variable** – EMF of the concentration cell – $E(\text{cell}) / V$ – as measured by the voltmeter. This will depend on the relative concentration of the two electrolytes as can be predicted from the Nernst equation.
- **Depend on Variable** – Change in Gibbs free energy (ΔG). This value depends on the EMF of the cell produced. The ΔG value can either be positive or negative for a system and can determine the direction in which the equilibrium will shift. A negative ΔG indicates the conversion of reactants to products while a positive ΔG means a conversion of products to reactants.

HYPOTHESIS

It is hypothesized that as the difference between C_1 and C_2 will increase, there will occur a larger change in ion concentration in both half-cells – resulting in a larger EMF of the concentration cell.

Further, by the relation: $\Delta G = -nFE$, it is also predicted that the absolute value of ΔG will be larger. Therefore, an increasing trend in EMF and ΔG is predicted with a decreasing C_2 .

⁸ Sciencelab.com. (n.d.). *Material Safety Data Sheet*. Copper sulphate pentahydrate MSDS. Available at: <http://www.sciencelab.com/msds.php?msdsid=9923597>

⁹ Figure 2f from: Irimia R, Gottschling M (2016) Taxonomic revision of *Rocheffortia* Sw. (Ehretiaceae, Boraginales). *Biodiversity Data Journal* 4: e7720. <https://doi.org/10.3897/BDJ.4.e7720>

RAW DATA / QUALITATIVE OBSERVATIONS

Table 1: EMF Reading in Voltage (V) as measured by the voltmeter for different concentration values of C_2 when $C_1 = 0.5M$

Concentration C_2 (M)	EMF Reading ($E_{CELL} / V \pm 0.001$)			
	Trial 1	Trial 2	Trial 3	Trial 4
0.5	0.006	0.004	0.005	0.004
0.05	0.030	0.029	0.032	0.028
0.005	0.053	0.052	0.054	0.053
0.0005	0.075	0.072	0.074	0.072
0.00005	0.090	0.089	0.088	0.092

- Decreasing the concentration of the $CuSO_4$ solution saw a fading of the dark blue colouration to a paleblue and eventually almost colourless.
- After a few trials, the anode had lost some of the reddish-brown colour – lost Cu atoms.
- The voltmeter reading would last for a few seconds and then start decreasing – eventually dropping down to zero.

PROCESSING OF DATA / PROPAGATION OF UNCERTAINTIES

Restating the Nernst Equation for a concentration cell 25°C:

$$E = E^\circ - \frac{(0.0591 \text{ volts})}{n} \log_{10} Q$$

When we consider an electrolyte concentration cell, the two electrodes used are of the metal – copper – and are at the same pressure (concentration). Therefore, even the half-reactions at the cathode and anode are identical – at one Cu atoms convert to Cu^{2+} ions while the reverse occurs at the other electrode. This implies that the standard reduction potentials at the two electrodes are also the same. Therefore in

$$E^\circ (\text{cell}) = E^\circ_{1/2} (\text{reduction}) - E^\circ_{1/2} (\text{oxidation}) = E^\circ_{1/2} (\text{cathode}) - E^\circ_{1/2} (\text{anode})$$

We can say that $E^\circ_{1/2} (\text{reduction}) = E^\circ_{1/2} (\text{oxidation})$, and so

$$E^\circ (\text{cell}) = 0$$

Or the standard cell potential is zero. The Nernst equation can thus be rewritten as

$$E = - \frac{(0.0591 \text{ volts})}{n} \log_{10} Q$$

The difference between the two half-cells is based on the metal ion concentration. Considering the explained redox changes occurring at the electrodes, the chemical equation can be given as

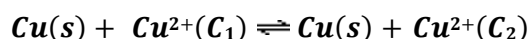

Q – as defined earlier – is the reaction quotient and is in the form of the equilibrium equation but with initial concentration values. This is written as

$$Q = \frac{\text{Cu}^{2+}(\text{C}_2)}{\text{Cu}^{2+}(\text{C}_1)}$$

The Nernst equation thus becomes

$$E = - \frac{(0.0591 \text{ volts})}{n} \log_{10} \frac{\text{Cu}^{2+}(\text{C}_2)}{\text{Cu}^{2+}(\text{C}_1)}$$

This equation being of the form $y = mx$ where m is the slope of the line, this equation can be plotted using the experimental values of E and $\log Q$. Next, we average the EMF values provided in Table 1. This will partially account for the fluctuations and imprecision in the readings – with the uncertainty remaining the same in the average.

Sample Calculations: $C_2 = 0.5M$,

$$\text{Average } E = \frac{0.006 + 0.004 + 0.005 + 0.004}{4} = 0.00475 \text{ V}$$

$$\Delta \text{Avg } E = \frac{(0.001 + 0.001 + 0.001 + 0.001)}{4} = 0.001 \text{ V}$$

Table 2: Average EMF Reading for each C_2 concentration with $C_1 = 0.5M$

Concentration C_2 (M)	Average EMF Reading (Avg $E_{\text{CELL}} / \text{V} \pm 0.001$)
0.5	0.005
0.05	0.030
0.005	0.053
0.0005	0.073
0.00005	0.090

Based on the simplified Nernst equation, we are supposed to have the term $\log_{10} \frac{\text{Cu}^{2+}(\text{C}_2)}{\text{Cu}^{2+}(\text{C}_1)}$ along the x-axis and the E values on the y-axis. We therefore can find the $\log Q$ values as given below.

Sample Calculations: For $C_2 = 0.05M$,

$$\log_{10} Q = \log_{10} \frac{\text{Cu}^{2+}(\text{C}_2)}{\text{Cu}^{2+}(\text{C}_1)} = \log_{10} \frac{0.05}{0.5} = -1$$

Table 3: Log Q and Average EMF Values for different C₂ Values

Concentration C ₂ (M)	$\log_{10} \frac{Cu^{2+}(C_2)}{Cu^{2+}(C_1)}$	Average EMF Reading (Avg E _{CELL} /V ± 0.001)
0.5	0	0.005
0.05	-1	0.030
0.005	-2	0.053
0.0005	-3	0.073
0.00005	-4	0.090

The plot of Average EMF versus the $\lg \frac{Cu^{2+}(C_2)}{Cu^{2+}(C_1)}$ should provide a straight-line graph with a slope equal to the value of $-\frac{(0.0591 \text{ volts})}{n}$.

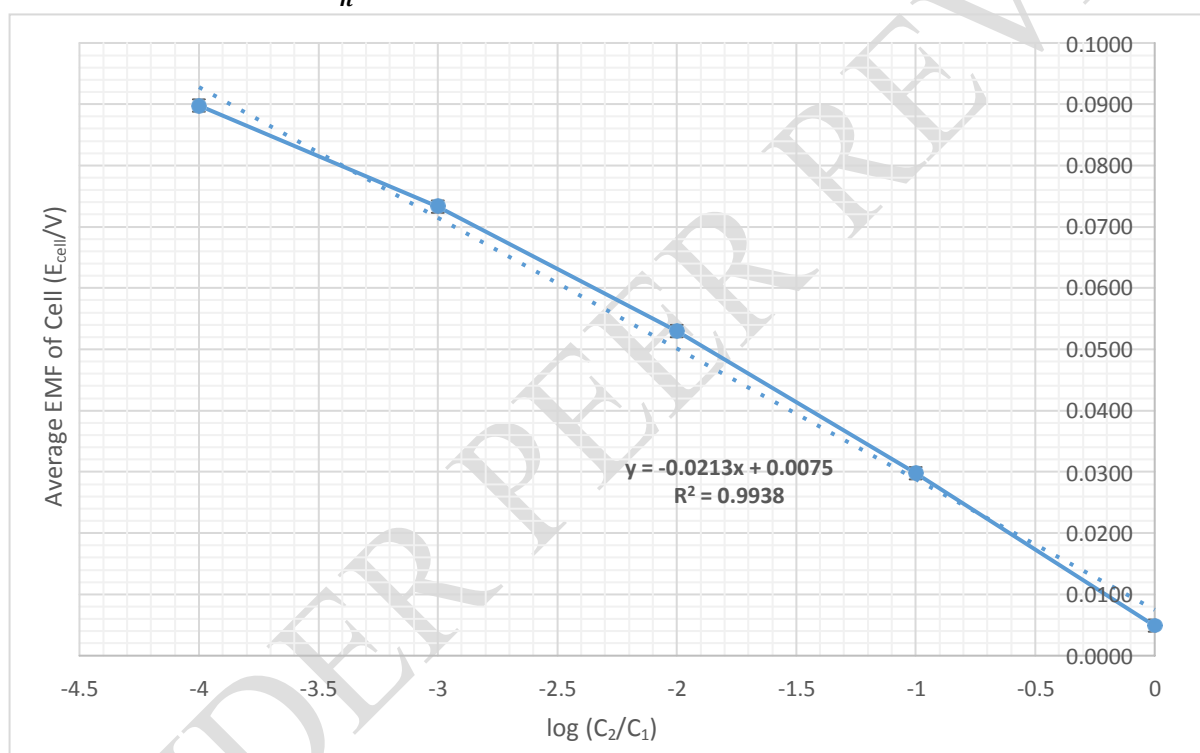

Graph 1: Average EMF (E_{CELL} / V) versus log (C₂/C₁)

Graph (1) – also called the Nernst Plot – displays the relationship between the E_{CELL} value at different C₂ concentrations and the log Q term. The graph appears to be curved with an intercept on the y-axis at the point 0.005 V.

Looking at the Nernst equation, it could be perceived that when the log Q term would be zero, mathematically even the EMF recorded would be zero. This stems from the fundamental working principle of such a concentration cell – the voltage is produced due to the difference in concentrations of the electrolytes. However, when the C₂ value is equal to C₁ (=0.5 M), there shouldn't be any current flowing through the circuit and therefore the EMF value should be zero. This could be either because of a faulty reading in the voltmeter or it is possible that due to some systematic error like an undried beaker, the relative concentration was affected and a very small voltage was created. The small error bars shown refer to the ±0.001 V uncertainty involved due to the voltmeter. This value becomes fairly

significant when dealing with the first reading – consider slightly erroneous – where E_{Cell} equals 0.005 V. Further if we consider the R^2 value of the trend line plotted for the graph – which comes to a high 0.9938 – the E values appear highly proportional to the $\log\left(\frac{C_1}{C_2}\right)$. Although the graph doesn't pass through the origin, it isn't a straight line.

Plotting the trendline to the graph, we get the equation of the line to be $y = -0.0213x + 0.0075$

The slope of this equation corresponds to the following term in the Nernst Equation

$$-\frac{0.0591}{n}$$

Theoretically, we find the slope when Cu electrodes are used. The n value – or the number of moles of electrons exchanged in the reaction – is 2. ($2e^-$ lost by Cu atoms while $2e^-$ gained per Cu^{2+} ion)

Therefore the theoretical slope is

$$\text{theoretical slope} = -\frac{0.0591}{2} = -0.02955 \approx -0.0296$$

The percentage discrepancy between the experimental and theoretical slopes thus is

$$\begin{aligned} \% \text{ discrepancy} &= \frac{\text{theoretical slope} - \text{experimental slope}}{\text{theoretical slope}} \times 100 \\ \% \text{ discrepancy} &= \frac{-0.0296 - (-0.0213)}{-0.0296} \times 100 = 27.87 \approx 28\% \end{aligned}$$

Considering the small magnitude of the voltage values measured, the percentage discrepancy of 28% is fairly small – denoting the accuracy of the data collected. Further, using the relation $\Delta G = -nFE$, we can calculate the ΔG value for the different E values at different C_2 concentrations.

Sample Calculations: For $C_2 = 0.005\text{M}$, Avg $E_{\text{CELL}} = 0.0530\text{V}$. Therefore,

$$\Delta G = -2 \times 9.65 \times 10^4 \times 0.053 = -10229 = -10.23 \text{ kJ mol}^{-1}$$

$$\text{Uncertainty in } \Delta G = \frac{\Delta \text{Avg } E_{\text{CELL}}}{E_{\text{CELL}}} = \frac{0.001}{0.053} = \pm 0.02 \text{ kJ mol}^{-1}$$

Table 4: Change in Gibbs free energy for the electrochemical reaction for different values of C_2

Concentration C_2 (M)	Average EMF Reading (Avg E_{CELL} /V ± 0.001)	Change in Gibbs free energy ΔG ($\text{kJ mol}^{-1} \pm 0.02$)
0.5	0.005	- 0.93
0.05	0.030	- 5.75
0.005	0.053	- 10.23
0.0005	0.073	- 14.15
0.00005	0.090	- 17.33

We can thus have a plot for the relation between C_2 and ΔG as shown in Graph (2). As we can see, for an increasing value of C_2 , we see a rising curve – indicating that the absolute value of ΔG is increasing. However, it is becoming less and less negative. This relates to the spontaneity of the chemical reaction.

More negative the value of ΔG , the greater the spontaneity of the reaction – which means that the reaction

UNDER PEER REVIEW

occurring without any input energy will move in the forward direction to produce more products. This relates to the fact that the electrochemical cell involves spontaneous reactions and in a concentration cell, the greater the difference between the concentrations of the electrolytes (smaller C_2 value), the more spontaneous the reaction. Therefore, for an increasing C_2 value – when the average E_{CELL} value keeps dropping – the change in Gibbs free energy keeps decreasing in magnitude and becomes less and less negative.

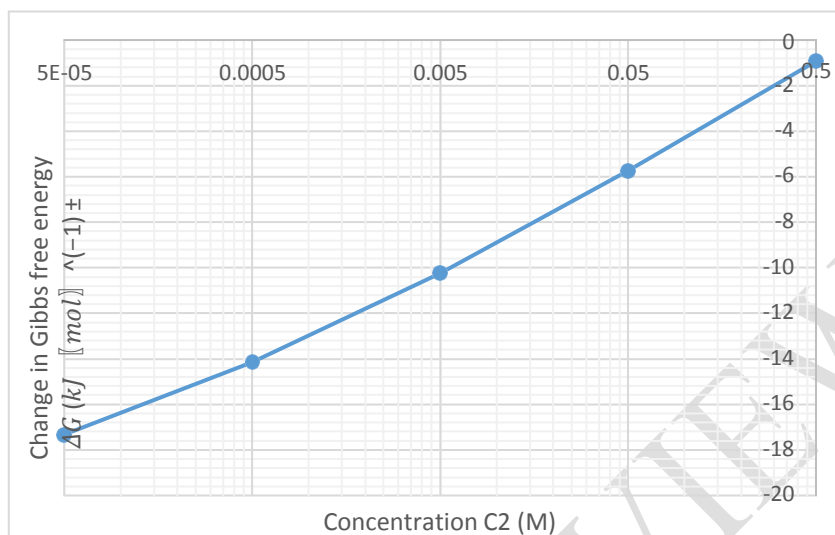

Graph 2: Change in Gibbs free energy versus Concentration C_2

CONCLUSION

Considering the research question - *How does the relative concentration of the CuSO_4 electrolytes in the two half-cells of an Electrolyte Concentration cell affect the resulting EMF and change in Gibbs free energy produced?* – the conducted experiment sought to establish a relation between the difference of value between C_1 and C_2 , and the result E_{CELL} measured by the voltmeter. Tables (1) and (2) indicated that with a constant C_1 value equal to 0.5 M, the recorded voltage increased with an increase in the C_2 value. This means that as the second half-cell contained an increasingly dilute electrolyte CuSO_4 as compared to the electrolyte in the C_1 beaker, the EMF generated across the electrolyte concentration cell grew larger. This is based on the fact that the electrolytes try to achieve concentration equilibrium via reduction and oxidation occurring at the cathode and anode respectively.

Further, the Nernst plot graphed displayed a correlation between the $\log\left(\frac{C_1}{C_2}\right)$ term and the average EMF value recorded. The high R^2 value of 0.9938 indicated that the dependant variable – the logarithmic term through variation of C_2 – and the independent variable – the E value – were highly proportional but not directly proportional as was expected. The uncertainty in the voltmeter reading or even perhaps some systematic or random error may have caused this variation – along with the percentage discrepancy of 28% between the experimental and theoretical slope of this plot. The change in Gibbs free energy calculated for the electrochemical reaction for each C_2 value indicated a decreasing trend with an increasing C_2 concentration. It was thus observed that as C_2 increased, or the difference in concentrations of the two electrolytes decreased, the spontaneity of the reaction decreased.

EVALUATION AND FURTHER SCOPE

The experiment aimed at establishing a link between the varying concentration of the electrolyte in one half-cell of a concentration cell and the resulting EMF generated across the cell. Further, it also drew a connection between this variation and the change in Gibbs free energy for the electrochemical reaction. While the experimental setup and procedure were fairly standard as to the working of a concentration

cell, certain nuances were essential. Maintaining the electrodes vertical was essential so that the surface area exposed in both electrolytes and in all trials remained the same. Even scraping of the electrolyte after certain trials helped maintain the efficiency of the system.

However, a huge source of error is the fact that while 0.5M CuSO₄ solution being used is given, the solutions produced subsequently are assumed to be of the right concentrations based on the procedure followed to make them as well as the colouration. This could impact the value of Q – allowing a certain degree of systematic error to creep into the data. This could be avoided by using a concentration probe to check the concentration of each solution used before its trials are taken. This will greatly enhance the accuracy of the concentration achieved. Using multiple solutions already ready in the lab could also be useful – perhaps the most accurate – but will involve a fair amount of waste of chemicals.

An observation that was recorded was the gradual decrease in the voltmeter reading during each trial. For example, when C₂ = 0.00005 M, the voltmeter reading for the four trials would be given as the data provided in Table (1) but would begin to decrease after a few seconds – eventually dropping down to zero. This wasn't an error due to the experimental procedure but is related to the concentration difference between the two electrolytes. The current flowed in the external circuit as long as the unequal C₁ and C₂ values caused the electrical charging of the electrodes through the redox reactions. However, as the reduction and oxidation occurred, the Cu ion concentration in both half-cells grew closer numerically and when these equalized, no more electrons were gained or lost – leading to no charge on the electrodes and hence no voltage.

An advantage of this concentration-induced change in Gibbs free energy is that when the concentration difference is greater, the ΔG value is larger. This means that the spontaneity of the reaction increases and the forward reaction is more favoured. This rise in spontaneity can increase the efficiency of industrial processes which involve batteries or work on the principle of concentration cells as the input energy required would be much lower if not negligible.

Electrochemical cells are considered to be excellent sources of energy and a lot of research and development is being undertaken to enhance their abilities. As demonstrated by the experiment, a concentration cell tends to produce moderate or even small voltages (at room temperature) for short periods – because the concentration soon equalizes. Consequently, devices employing such cells are considered unviable for energy storage – where large voltages are necessary. However, research conducted at the Department of Chemical and Biological Engineering at Northwestern University, displays how citric acid molecules (involved in the half-reactions at the electrodes of a concentration cell) are tethered onto magnetic nanoparticles and a sharp concentration gradient is maintained between the two electrodes using an external magnetic field produced by a permanent magnet. These cells produce a voltage as high as 0.5 V for over 100 hours – having the ability to generate enough electricity to power our ordinary calculators and timers. Involving no corrosion of electrodes, producing no harmful by-products and having the advantage of reusability – this enhancement of the ordinary concentration cell is an inspiration to the kind of work I aspire to do as an engineer, hoping to develop devices and methodologies to help the sustainability goal.¹⁰

¹⁰ Yan Y, e. (n.d.). *A long-lasting concentration cell based on a magnetic electrolyte.* - PubMed - NCBI. Ncbi.nlm.nih.gov. Available at: <http://www.ncbi.nlm.nih.gov/pubmed/25262332>.

References

- AskIITians.com. (2018). *Concentration Cell - Study Material for IIT JEE | askIITians*. Available at: <http://www.askiitians.com/iit-jee-chemistry/physical-chemistry/concentration-cell.aspx>
- Chemistry LibreTexts. *Electrolytic Cells*. [online] Available at: https://chem.libretexts.org/Core/Analytical_Chemistry/Electrochemistry/Electrolytic_Cells
- Chemistry.stackexchange.com. (2018). *Why is it important to use a salt bridge in a voltaic cell? Can a wire be used?* Available at: <https://chemistry.stackexchange.com/questions/5477/why-is-it-important-to-use-a-salt-bridge-in-a-voltaic-cell-can-a-wire-be-used>
- Chieng, C. (2018). *Half Cell Reactions*. Science.uwaterloo.ca. Available at: <http://www.science.uwaterloo.ca/~cchieh/cact/c123/halfcell.html>
- Explain that Stuff. (2018). *How do pH meters work? | Measuring acidity*. Available at: <http://www.explainthatstuff.com/how-ph-meters-work.html>
- ThoughtCo. (2018). *What the Nernst Equation Is and How to Use It*. Available at: <https://www.thoughtco.com/nernst-equation-electrochemistry-equations-606454>
- Webassign.net. (2018). *Lab 13 - Electrochemistry and the Nernst Equation*. Available at: http://www.webassign.net/labsgraceperiod/ucscgenchem11/lab_13/manual.html
- Yan Y, e. (n.d.). *A long-lasting concentration cell based on a magnetic electrolyte*. - PubMed - NCBI. Ncbi.nlm.nih.gov. Available at: <http://www.ncbi.nlm.nih.gov/pubmed/25262332>.