

# Design of Digital Twin System for Harbor Cranes Based on Unity 3D

## ABSTRACT

Digital twin as a link between physical space and digital space, is based on a new generation of information technology, can be completed in the digital space of the real space mapping, so as to reflect the corresponding physical equipment of the whole life cycle process. In order to prevent heavy machinery in the operation process of fatigue fracture and other major accidents, its this paper to shore container crane as the object of study, to achieve its simulation and three-dimensional visualization feedback, so as to achieve human-computer interaction, to be able to clearly know the crane's operating status. First of all, the use of three-dimensional modeling software to build its three-dimensional geometric model and imported into unity. at the same time, in order to realistically restore the shoreline scene, in unity to build a virtual environment of the port; and C # development of the crane's main operating mechanism of the drive engine, to achieve the synchronous operation of the digital twin model.

*Keywords: Shore Container Crane, Digital Twin, Unity 3D, Digital Twin System*

## 1. INTRODUCTION

In the context of world peace, countries began to pursue economic development and gradually develop international trade, the port is an important place for international exchanges, 90% of the volume of international trade is completed in the port by sea[1]. In recent years, in order to meet the requirements of cargo loading and unloading process and loading and unloading speed, the level of mechanical automation in ports has been greatly improved, and port cranes have become more and more important as the main equipment for loading and unloading cargo[2]. In view of the complexity and harshness of the port environment, the port crane load, port cranes are often structural aging fracture, failure, machine instability, wear and other safety hazards[3]. In order to therefore correctly predict the stress, deformation and future failure of harbor cranes during operation, it is of great significance for the safe operation and health management of harbor cranes.[4-5]

As a link between physical space and digital space, digital twin can be used to establish a real mirror image of the whole life cycle of material selection, structural design, processing and manufacturing, and operation and maintenance management of physical entities in digital

**Comment [AB1]:** References should be cited using citation software like Endnote, Mendeley, etc. not by hand. Such kinds of writing are strictly prohibited in the academic world.

**Comment [AB2]:** Ditto.

**Comment [AB3]:** Ditto.

**Comment [AB4]:** Ditto

space[6-7]. Port crane digital twin as an effective means of real interaction, health monitoring, through the physical space to the virtual space of the dynamic mapping, to achieve the real and virtual closed-loop interaction in manufacturing activities[8].

Digital twin concept prototype was created in 2003, by the University of Michigan Professor Michael Grieves in the full life cycle management (PLM) concept of idealization was put forward, and then on the concept of digital twin expression has evolved into a "mirror space model", "information", "mirror model" concept[9-10]. Up to this point, the terminological expression of digital twin technology has undergone many shifts, but the core of the digital twin remains unchanged, i.e., the technology is defined by the physical space, the digital space, and the data and information that can link the two spaces together [11]. 2010, NASA proposed the "Digital Twin" in its Integrated Technology Roadmap[12]. 2011, NASA proposed the "Digital Twin" in its Integrated Technology Roadmap. "In 2011, NASA applied digital twin technology to space vehicles to realize the simulation and analysis of space vehicles, monitor their flight status and predict their future flight status, and feedback the predicted status to operators on the ground to help them make optimal decisions[13-15]. So far, many famous foreign research institutions and enterprises have realized the value of digital twin technology and started to actively explore digital twin technology. In China, domestic scholars also began to explore digital twin technology in 2017. The team led by Tao Fei, a scholar at Beijing University of Aeronautics and Astronautics, launched an in-depth study of digital twin technology, proposed a five-dimensional model of digital twins, and put forward the theory and application of digital twin model construction[16]. Digital twin technology has been the focus of more and more scholars at home and abroad, the digital twin market is gradually expanding, and at the same time, the development of digital twins has risen to the level of national strategy[17-18]. Countries have introduced relevant policies as an important supporting condition for the development of digital twin technology. According to the report "China Digital Twin City Market Analysis, 2021" published by International Data Corporation (IDC), the global digital twin market size was at \$7.47 billion in 2021 and is expected to reach \$26.46 billion in 2025[19]. Driven by the national strategy and market demand, China's digital twin technology market size is also gradually climbing upward. According to relevant departments, China's digital twin technology market size was about 2.7 billion yuan in 2014, growing to about 13.7 billion yuan in 2020, with a compound growth rate of 31.1%[20].

The Shorebridge digital twin system can realize the mirroring of devices in the physical world in the digital world, and the operational data of the Shorebridge can drive the geometric model to move along with it, so that the geometric model can become a true twin model[21]. The twin model in turn can discover the laws from its repeated operation, predict various conditions of the bridge and make feedback, so that dangerous situations can be detected in advance to ensure the safety of personnel and goods. Digital twin technology has flourished in recent years, with several successful applications in smart factories and smart cities[22-23]. However, there is no successful application case for product-level equipment, which still needs to be explored in depth. Most scholars have proposed a digital twin framework for equipment operation, while others have not realized the interoperability between the real and the virtual, especially for the digital twin of major equipment, and there is still much room for exploration.

# 1 SHOREBRIDGE MODELING ROADMAP

This topic in the construction of digital twin model, you need to build a complete three-dimensional model of the shore bridge operation, the entire model not only contains operational equipment, but also to maximize the restoration of the port operating environment[25]. Not only to ensure the consistency of the digital space with the real scene, but also to maximize the restoration of the real scene of the real degree of realism, so that the visual sense of reality. The modeling technology roadmap is shown in Figure 1.

**Comment [AB5]:** What does it mean? Please rewrite it in a good way.

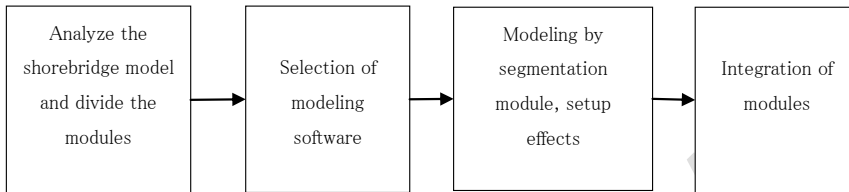

**Figure 1 Modeling technology roadmap**

First of all, analyze the modeling needs, systematically plan the modeling modules, such as shore bridge, container, etc., and determine the specific relationship between the models; then choose the appropriate modeling software according to the need for modeling requirements; then according to the modules are modeled separately, and ultimately the modules will be assembled collectively.

**Comment [AB6]:** Figures should be inserted as a caption automatically, not by hand.

# 2 META-ACTION THEORY ANALYSIS DURING SHORE BRIDGE OPERATIONS

For the different working requirements of the quay bridge, through the operation of the manipulator system of various manipulators and related rods, will produce the corresponding electrical signals, the electrical signals are transmitted to the digital operation of the operating electronic system, so that the corresponding part of the program to start, and ultimately produce the output signals, transmitted to the motor, the motor is responsible for the output of electrical energy, speed or torque, the process of that is to achieve the output from the manipulation of manipulators to the speed, torque[26]. Then the movement and torque are transferred through the coupling, and then the power of the equipment is reduced through the reduction gearbox to meet the speed required for the operation of the equipment, which drives the drum to realize the extension and retraction of the steel wire rope, thus realizing the behavior of the hoisting mechanism and the operating mechanism to lift the containers. The signal flow diagram from the operating system to the shore bridge operation is shown in Figure 2.

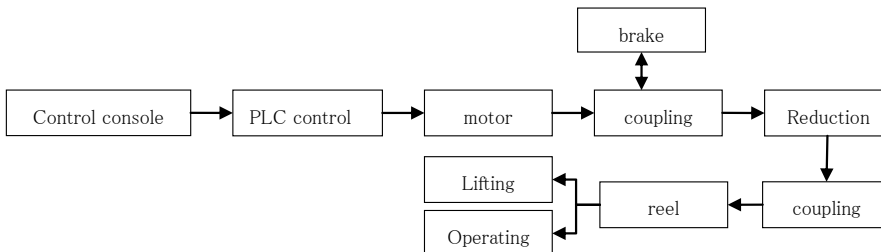

**Fig. 2 Flowchart of shore bridge signal transmission**

Comment [AB7]: Ditto

Crane operation is controlled by the flow of information flow of energy flow, from the console issued by the PLC control of a variety of electrical signals transmitted to control the motor to send out power, the intermediate through the reduction gearbox, coupling torque transfer, and ultimately control the lifting mechanism and trolley running mechanism both combined with the handling of the container action. Therefore, the drive transmission system is the core part of the crane, the premise of its digital twin is the structure of the crane drive transmission system and its performance for the correct and detailed decomposition. According to the operating conditions of the crane, it has two operating conditions of mobile crane equipment, handling containers, in which the handling of containers includes three stages of lifting, panning and placing containers, and ultimately determines that the crane has two sub-functions of moving the crane and loading and unloading containers. These two sub-functions are completed by the large vehicle operating mechanism, lifting mechanism and small vehicle operating mechanism. Therefore, according to the function-motion-action (FMA) dynamic decomposition, the crane drive transmission system has only two independent meta-action chains[27-29]. The trolley operation mechanism ensures the sub-function of moving the crane, which is mainly composed of motor rotation meta-action unit and gear rotation meta-action unit to complete the adjustment of the crane operating position. The trolley running mechanism and hoisting mechanism work together to complete the loading and unloading of containers sub-function, which is mainly composed of motor rotation meta-action unit, gear rotation meta-action unit to realize the crane loading and unloading of goods sub-function.

Meta-action is the most basic form of motion to transfer momentum and movement when mechanical equipment is started[30-31]. The basic unit of meta-motion is called meta-motion unit[32]. Meta-action is a process quantity, according to the sequence of connection, can realize the power and motion transfer of the meta-action constitutes the meta-action chain, meta-action chain is the most basic form of functional movement[33]. Meta-motion theory analysis method is to analyze the complete motion form of mechanical equipment from the start-up phase, intermediate motion phase to the braking phase during the start-up operation, and it is a kind of dynamic analysis method, which has a unique advantage in solving the problems of the motion of mechanical products[34-35]. By analyzing the whole motion chain of the equipment movement can make the movement process of the equipment clear, and can be used as a basis to study the movement process of the digital twin model of the equipment, laying a solid foundation for the dynamic interaction of the digital twin.

The meta-motion chain during the operation of the shore bridge focuses on analyzing the whole process of the operation of the shore bridge based on each meta-motion, which consists of three parts: the starting input motion, the motion transfer link and the target output motion. When the coast bridge makes a single container handling movement from the sea side to the road side, the trolley mechanism is located on the front girder, and the running trajectory of the handling container is along the rail groove of the front girder. In order to reduce the impact of the trolley's operation, there is an automatic deceleration switch. The whole process of the container from the ship to the roadside truck can be divided into three stages of movement: the rising stage, the horizontal movement stage, the descending stage. These three stages of motion are acceleration stage, uniform speed stage and deceleration stage. Each stage has the same motion principle and motion state, and therefore has the same meta-action chain. The

meta-action chain model is shown in Figure 3.

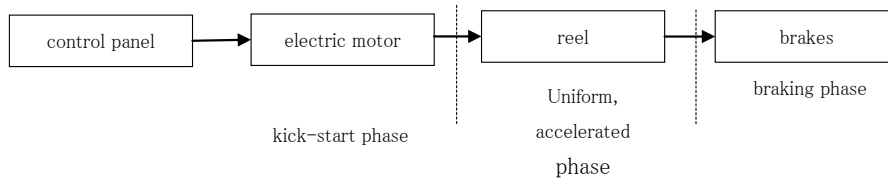

**Fig. 3 Meta-action chain model**

**Comment [AB8]:** Ditto

### 3 OVERALL SYSTEM ARCHITECTURE

The digital twin system architecture of harbor crane is shown in Figure 4, which consists of equipment layer, data layer, software layer and display layer[36].

The equipment layer is mainly composed of the trolley traveling mechanism, the trolley traveling mechanism and the hoisting mechanism, and it is used to obtain data information such as the running speed of the trolley and the position of the trolley by simulating the real crane operation in the simulation software.

By simulating the real crane operation in the simulation software, to obtain the running speed of the trolley, the position of the trolley and other data information.

The data layer mainly acquires and stores the key data information of the crane, which can be intercommunicated with the three-dimensional interface of unity, realizing the twin model and the simulation model are related to each other and interconnected.

The software layer is the platform for visualization of the twin model, which mainly contains the crane model, the simulation of the natural environment of the port of the sky, the ground module, etc., as well as each runnable model is mounted on the C# script program that can realize the corresponding functions.

The display layer is the graphical user interface, which can display the data describing the specific operating status of the crane to the interface, thus realizing human-computer interaction.

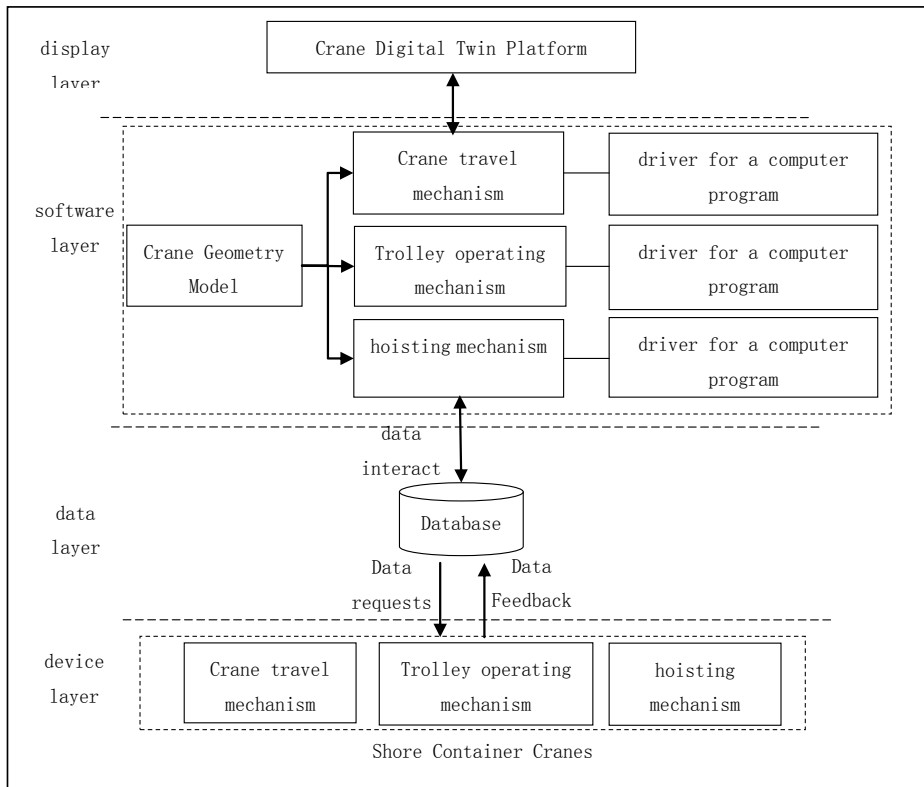
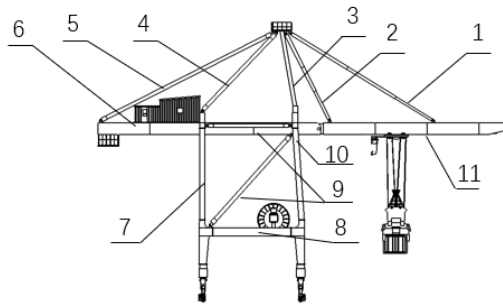

**Fig. 4 Port Crane Digital Twin System Architecture**

### 3.1 EQUIPMENT LAYER

The basic composition of the shore bridge includes:

- (1) **Driving device:** the lifting mechanism, trolley running mechanism and large trolley running mechanism of the shore bridge have their own driving motors. The trolley running mechanism generally adopts AC frequency conversion speed control system, and the object of this study has four motors to drive the trolley running. The large vehicle running mechanism is driven by one or more sets of driving devices.
- (2) **Working mechanism:**
  - (a) **Lifting mechanism:** the most basic mechanism that can control the lifting and lowering of items, consisting of motor, wire rope winding system and fetching device.
  - (b) **running mechanism:** there are two kinds of trolley running mechanism and trolley running mechanism. Trolley running mechanism to realize the horizontal movement of the container. The large vehicle running mechanism makes the whole shore bridge move along the track.
- (3) **manipulation system:** including a variety of manipulators, monitors and related components and lines, according to the operational needs of the corresponding operating signals.
- (4) **equipment structure:** equipment structure including beam system, gantry system, tie rod system. The three systems together support the load generated during the operation of the equipment as well as the self-weight, providing sufficient operating space and a stable operating foundation for the operation of the shore bridge. The metal structure of the bridge is shown in Figure 5.



**Fig. 5 Metal structure of the shore bridge**

1-Front large tie rod; 2-Front center tie rod; 3-Sea survey trapezoidal frame; 4-Rear gusset; 5-Tail tie rod; 6-Rear girder; 7-Landside riser; 8-Portal frame contact beam; 9-Portal frame gusset set; 10-Sea-side riser; 11-Front girder

### **3.2 DATA LAYER**

In the data layer, this paper first uses the simulation software Adams to simulate the loading and unloading operation state of the shore container crane, so as to obtain the real-time position and operation speed of the large truck operating mechanism, small truck operating mechanism, hoisting mechanism, etc. of the shore container crane, the spreader expansion and contraction dimensions and load, the quality of the containers under the spreader, and the equipment failure information and other data.

This design uses SQL Server2022 database software to store and manage the key operating data of the large vehicle operating mechanism, the small vehicle operating mechanism and the lifting mechanism. SQL is a widely used relational database with the advantages of lightweight, high-speed, stable and cross-platform, and the open-source database source code ensures the security of the data from the software level and realizes the digital twin system to the database for data usage extraction. In the database, according to the functional requirements of the container terminal digital twin system, a good database structure is designed, and the data are categorized and managed according to the data source, data use, data type and so on.

The realization of the data-driven model depends on the collectability and callability of data. The overall architecture of the real-time data-driven model can be described in three layers: presentation layer, logic layer and data layer[37]. This is shown in Figure 6:

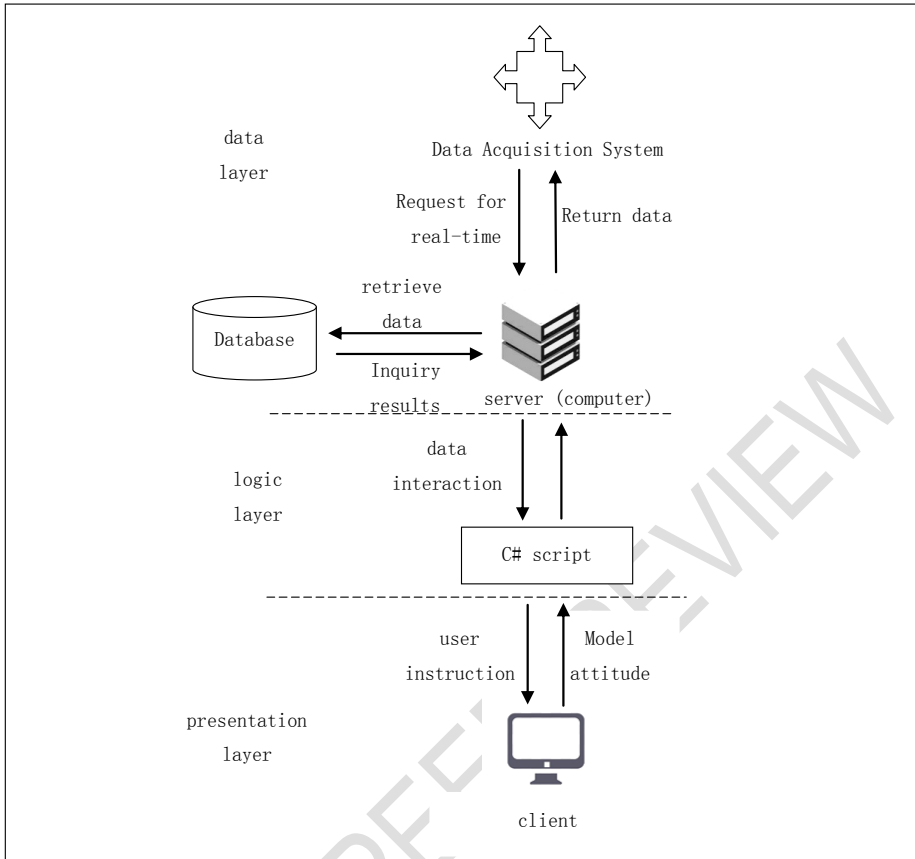

**Fig. 6 Data-driven schematic diagram**

### 3.3 SOFTWARE LAYER

The virtual scene of the software layer mainly contains the shore container crane model, static models such as container, ground, lighting system, sky box, etc., as well as the graphical user interface. The crane model is constructed using a geometric model with a 1:1 ratio to the real crane. Among them, the metal structure of the shore bridge is shown below for a better understanding of the shore bridge.

The model has the same operating mechanism as the real equipment such as the big car, small car, pitching mechanism, hoisting mechanism, spreader and so on. Driven by the scripts and data loaded on the three major motion structures, each mechanism can move individually, which can imitate the real scene of crane loading and unloading goods.

By analyzing the shore bridge model, comprehensive consideration of the shore bridge operating scenarios, it is determined that the virtual model established in the digital space includes three major parts: static model, dynamic model, graphical user interface. The structure of the digital space model is shown in Figure 7.

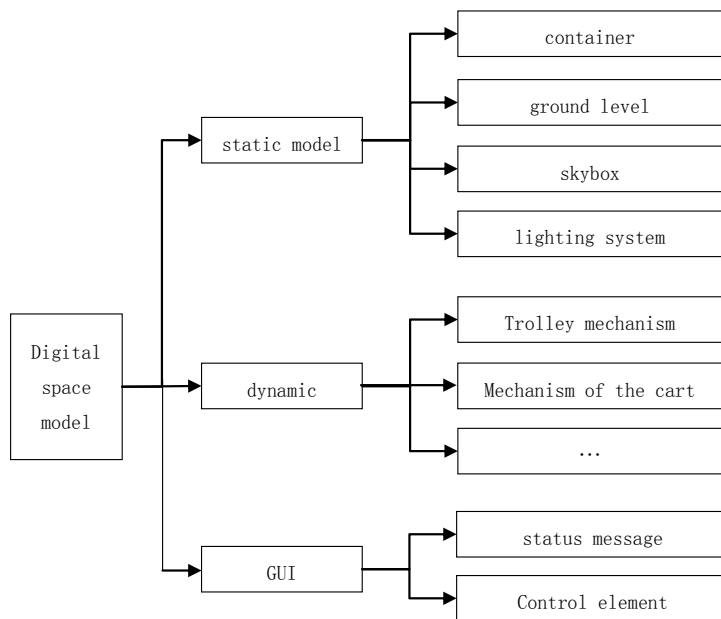
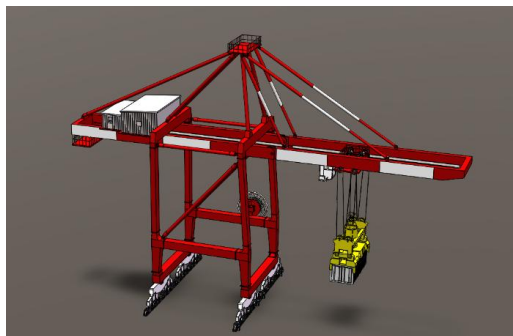

**Fig. 7 Structure of the digital space model**

Shore container cranes, equipment size is huge, lifting containers need to maintain a very small error in order to achieve accurate lifting containers, so the construction of high-fidelity, accurate model is directly related to the accuracy of the twin system. Constructing the virtual model This topic uses a total of three software, respectively SolidWorks, 3ds MAX and Unity 3D.

In SolidWorks, the three-dimensional model of the shore container crane is constructed according to its actual size. Considering the huge size of the equipment, some parts of the equipment for the operation of the experiment has a minimal impact on its fine modeling will increase the burden of computer operations, so the construction of the geometric model will not affect the experimental results of the parts to do a simplified[38]. After the geometric model was constructed, a simpler rendering was performed in SolidWorks. The geometric model was imported from SolidWorks into 3ds MAX in .STEP format. due to the differences between software versions, SolidWorks2021 and 3ds MAX2022 were used in this project. then the 3D model of the crane was imported into Unity software.

The 3D model of the shore container crane is shown in Figure 8.



**Figure 8. Geometric model of container crane on shore**

After the crane 3D model is constructed, it is then imported into the Unity software. In the scene, mapping and material rendering are performed on the models of equipment, buildings, etc., so that they have a real appearance and texture effect. In addition, the sky box and water effects are used in the scene to simulate the sky and the sea, so that the virtual 3D scene of the terminal has a similar visual effect with the real terminal.

### 3.4 DISPLAY LAYER

When the virtual three-dimensional scene of the container terminal is built, the system will generate images to the display layer of the monitor, the staff can visualize the crane's operating status. The display layer is accompanied by a human-computer interface, the user can click on the virtual scene of the running equipment or display interface buttons, query the basic parameters of the equipment, the current state, the current operating tasks, operation and maintenance status and other relevant information[39]. When the equipment works abnormally, the system will collect the fault information and transfer it to the virtual scene, and the corresponding equipment model in the scene will display text and flash alarm, so that the equipment maintenance personnel can quickly locate the faults according to the fault prompts. In addition, the display layer also has an interactive roaming function. Users can use the mouse, keyboard, etc. in the virtual scene according to the needs of independent zoom, move, rotate and other operations, to observe more crane detail information[40]. At the same time, users can also switch to different viewpoints through the button to monitor and observe the crane[41]. The crane scene in the digital twin platform is shown in Figure 9.

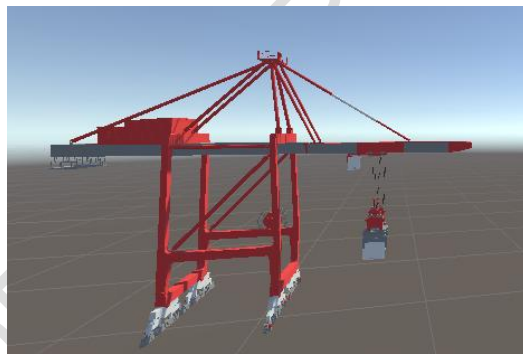

Fig. 9 Virtual 3D scene of the shore bridge

## 4.CONCLUSION

In this paper, Unity 3D software is used as the system development platform to design and develop the container terminal digital twin system. The digital twin system architecture of the shore container crane is proposed, and the digital twin platform of the shore container crane is designed; the meta-action theory is added to the crane digital twin; through this platform, the managers can conveniently and quickly understand the overall operation of the terminal, and discover and solve the problems arising from the process of container loading and unloading in a timely manner, so as to provide a strong guarantee for the efficient and reliable operation of the container terminal.

Comment [AB9]: Poor conclusion.

## REFERENCES

1. Chen Y P, Li H J, Wang R C, et al. Unity-based real-time 3D digital twin terminal design for robotic systems[J]. Machinery,2022,49(10):15-22.
2. Zhang Q, Jiang W Z, Qin X R, et al. Research and application of digital twin system for harbor crane based on VTK visualization engine technology[J]. Crane and Transportation Machinery,2020(17):69-74.
3. Song X G, Lai X N, He X W, et al. Key technology of digital twin for major equipment formability integration[J]. Journal of Mechanical Engineering,2022,58(10):298-325.
4. Lin C Z, Huang H, Zhang S X. Design of digital twin platform for manufacturing automated production line based on Unity[J]. Journal of Tangshan College,2023,36(03):38-43+84.
5. Yang R, Ning W Y, Zhang Y, Xu Y. Research on the design of digital twin system for automated container terminal[J]. Crane and Transportation Machinery,2022(05):57-61.
6. Yan S Y. Construction and evolution of digital twin model for welding robot [D]. Harbin University of Technology, 2021.
7. Lu J J. Research and implementation of TBM Virtual heading system based on Digital Twin [D]. Zhejiang University, 2021.
8. Gong R Z, Rao F, Ren N, et al. Construction and Realization of Visual Model of Stacker Digital Twin System [J]. Manufacturing Automation, 2022,44 (04): 154-157.
9. Tao F, Zhang M, Cheng J F, et al. Digital twin workshop-a new model for future workshop operation[J]. Computer Integrated Manufacturing Systems,2017,23(01):1-9.
10. Zhuang C B, Liu J H, Xiong H, et al. Connotation, architecture and its development trend of product digital twin[J]. Computer Integrated Manufacturing Systems,2017,23(04):753-768.
11. Tao F, Zhang H, Qi Q L, et al. Theory and application of digital twin model construction[J]. Computer Integrated Manufacturing Systems,2021,27(01):1-15.
12. Tao F, Cheng Y, Cheng J F, et al. Theory and technology of information-physical fusion in digital twin workshop[J]. Computer Integrated Manufacturing Systems,2017,23(08):1603-1611.
13. Tao F, Zhang H, Qi Q L, et al. Ten questions on digital twins:analysis and reflection[J]. Computer Integrated Manufacturing Systems,2020,26(01):1-17.
14. Tao F, Ma X, Hu T L, et al. Digital twin standard system[J]. Computer Integrated Manufacturing Systems,2019,25(10):2405-2418.
15. Li H, Tao F, Wang H Q, et al. Digital twin-based integrated development framework and key technologies for complex product design and manufacturing[J]. Computer Integrated Manufacturing Systems,2019,25(06):1320-1336.
16. Tao F, Liu W R, Zhang M, et al. Digital twin five-dimensional model and ten domain applications[J]. Computer Integrated Manufacturing Systems,2019,25(01):1-18.
17. Liu W R, Tao F, Cheng J F, et al. Digital twin satellites: concepts, key technologies and applications[J]. Computer Integrated Manufacturing Systems,2020,26(03):565-588.
18. Tao F, Zhang H, Qi Q L, et al. Theory and application of digital twin model construction[J]. Computer Integrated Manufacturing Systems,2021,27(01):1-15.

19. Guo L, Zhang Y. A review of progress in the application of digital twins in manufacturing[J]. *Mechanical Science and Technology*,2020,39(04):590-598.
20. Wu Y, Wang X J, He Y, et al. A review of key technologies and applications of digital twin in manufacturing[J]. *Modern Manufacturing Engineering*,2021,(09):137-145.
21. NIE F Q, NIE Y X, YANG W L, SUN Z R. Application of key technology for container cranes in smart ports[J]. *Construction Machinery Technology and Management*,2021,34(05):46-50.
22. He X W. Mechanism and data-driven digital twin design of gantry crane. Proceedings of the 17th Annual China CAE Engineering Analysis Technology Conference, 2021,21-25+33.
23. Zhou W, Wang L, Zhao T S, et al. Construction and application of digital twin model for construction process safety[J]. *China Production Safety Science and Technology*,2022,18(06):5-11.
24. Wu, DY. Digital Twin System Design for Multi-rotor Vehicles[D]. Southeast University,2021.
25. Shi QY. Research on virtual simulation technology of industrial robot application system[D]. Shanghai Second University of Technology,2020.
26. Hu F C. Research on real-time data-driven digital workshop based on Unity 3D [D]. Hunan University,2018.
27. Liu L. Research on the construction of virtual simulation system and collision detection technology of gantry machine tool based on digital twin [D]. Chongqing University of Technology,2021.
28. Zhang G B, Yang B, Ran Y, et al. Motion analysis method for mechanical products based on meta-action equations[J]. *Computer Integrated Manufacturing Systems*,2020,26(09):2412-2421.
29. Zhu G Y, Liu Y, Zhang G B, et al. FMA structured decomposition-driven machining center design process planning[J]. *Mechanical Science and Technology*,2017,36(08):1167-1174.
30. Zhang G B, Wang X, Ran Y, et al. Reliability modeling and fault diagnosis of complex electromechanical products based on meta-action decomposition[J]. *Journal of Chongqing University*,2017,40(08):9-18.
31. Zhang G B, Xu F W, R Y, et al. Research on similarity evaluation and reliability prediction of mechanical structures[J]. *Journal of Engineering Design*,2017,24(03):264-272.
32. Yang B, Zhang G B, Yu H, et al. A digital twin-based method for regulating the motion performance of mechanical products[J]. *Computer Integrated Manufacturing Systems*,2019,25(06):1591-1599.
33. Zhang G B, Liu J, Ge H Y, et al. Research on reliability-driven assembly process scheme[J]. *Mechanical Design*,2012,29(04):80-84.
34. Zhang G B, Jin CX, Ran Y, et al. A three-dimensional mass house optimization model for action layer[J]. *Journal of Harbin Institute of Technology*,2019,51(07):96-102.
35. Zhang G B, Liu J, Ge HY. Dynamic Bayesian network modeling and analysis of assembly reliability[J]. *China Mechanical Engineering*,2012,23(02):211-215.
36. Li D Y, Li M Q, Zhang G B, et al. Research on error source and error transfer modeling of meta-motion assembly unit[J]. *Journal of Mechanical Engineering*,2015,51(17):146-155.

37. Tao F, Cheng Y, Cheng J F, et al. Theory and technology of information-physical fusion in digital twin workshop[J]. Computer Integrated Manufacturing Systems,2017,23(08):1603-1611.
38. Zhang R C, Li C. Research on virtual simulation of rolling mill main drive system based on digital twin technology[J]. Modern Electronic Technology,2021,44(17):157-161.
39. Geng QQ. Research on robot condition monitoring technology based on digital twin simulation modeling[D]. Chongqing University of Posts and Telecommunications,2019.
40. Chen P, Liu C, CAI H H. Design of digital twin system for container terminal based on Unity 3D[J]. Port Technology,2021(07):8-10+42.
41. Wen J H. Digital twins for container terminals[J]. Lifting and Transportation Machinery,2021(1):83-86.

UNDER PEER REVIEW