

*Review Article*

**Pulsed Electric Field and Other Innovations in Electro-Technologies for Food Processing and Extraction of Bioactives from Fruit and Vegetables**

**Abstract**

Enhancing food safety and optimum shelf life can be achieved without compromising appropriate nutritional and sensory attributes of food by application of low temperature food processing technologies. Pulsed electric fields (PEF), high hydrostatic pressure, high intensity light, pulsed X-ray technology and microwave heating are emerging electro-technologies that effectively inactivate deleterious food microbes at ambient processing temperatures and short processing time. In this review, the principles of pulsed electric fields food processing were evaluated along with requirements for scale-up operation. Other latest development in the field of non-thermal processing methods were examined. In one study, PEF processing significantly improved the flavor and overall acceptability of tomato juice, grape juice, meat and processed sea foods. The microbial stability of PEF processed food is quite comparable to thermally processed product. PEF and other emerging innovative electro-technologies are continuously improving the sensory characteristics and shelf life of processed foods.

**Keywords:** Pulsed electric fields (PEF), Extraction, Bioactives, Food safety, Human health, Industrial application

**1. Introduction**

Preservation and reduction of detrimental changes in the sensory and physical properties of processed food products are becoming increasingly important as we strive toward satisfying consumers' demand for high quality food product. Conventional food preservation technologies are centered on prevention of microbial growth and/or microbial inactivation. This is often achieved by thermal treatment of processed foods. The target is to modify those specific factors that most effectively influence the growth and multiplication of microorganisms such as water activity or moisture content, temperature, pH, humidity and chemical additives[1]. This ensure that most microbial activities in the food product are effectively minimized throughout the shelf-life of such food products. However, microorganisms are not destroyed and will be metabolically active and viable under favorable environment. The net effect is reduced shelf-life.

To this end, alternative food processing technologies that preserve food sensory attributes including flavor and overall acceptability becomes desirable. Pulsed electric fields (PEF) is a non-thermal food processing technology involving short electric pulses over microseconds duration for microbial inactivation whilst maintaining desirable sensory attributes of food. PEF food processing technology is in many ways superior to the conventional thermal food preservation methods as it aims to reduce detrimental changes in flavor, texture, taste and fresh-like appeal. PEF technology is easily adaptable to liquid and semi-solid food products. It has been effectively employed on microbial inactivation of milk, egg products, tomato juice, carrot juice, apple juice, orange juice, pea soup and other liquid food products[2]–[5]. The pulsed electric field technology is considered today as the most promising non-thermal technique capable of microbial inactivation of food product over extended shelf-life [5].

In general, PEF food processing technology involves generation of short (microseconds to milliseconds) high voltage of electric fields in the range of 5-80KV/cm between two electrodes [6] to cause microbial inactivation at temperatures below thermally processed food products. Such microbial inactivation by PEF is generally accepted to follow electroporation of microbial membranes and thus, microbial inactivation[6]–[8]. Other nonthermal processing technologies such as high hydrostatic pressure, oscillating magnetic fields, photo-irradiation, ionizing radiation, gamma irradiation, ultra-sonication and application of chemical and biochemical additives and intense light pulses follow similar mechanisms and intended to keep food processing below the temperature of thermal processing. The overall goal

is to preserve the nutritional quality of food while consuming less energy than thermal processing methods.

During thermal processing of food, a number of changes take place in the food product that alter its final quality [8]. This include changes in appearance, color, flavor, taste, texture, mineral content and vitamins. Consumers are now showing preference for natural food products free of chemicals and additives[9]. The need to investigate and review an alternative food processing technology (PEF) capable of preserving the sensorial quality of processed food at minimal energy consumption become imperative. PEF and other aforementioned electro-technologies for food processing are not only cost-effective, when compared to the conventional thermal method, but environmentally friendly and above all, preserves food natural characteristics. High hydrostatic pressure (HHP) technique has also shown comparable promise in preserving nutrient content of food product especially in fruits and vegetables processing. The high pressure processing condition demonstrated little detrimental effect on one important phytonutrient (anthocyanin) responsible for antioxidant activity[10]. Similarly, HHP applied at ambient temperature has been reported to preserve important food quality including flavor, color and texture. This is because high pressure application preserve covalent bonds of processed food product[11]. In this review, the principles of PEF food processing technology will be examined in detail including experimental setup from laboratory to pilot scale, mechanism of microbial inactivation, impact on the shelf-life and sensory attributes of processed foods. Similar innovations in electro-technologies especially high hydrostatic pressure, oscillating magnetic fields, photo irradiation and ionizing irradiations will be examined.

### **1.1. Current Extraction Techniques for Fruits and Vegetables Bioactive Compounds**

The .....

### **1.2. An overview of Pulsed Electric Field and Electro-Technologies**

The basic components of PEF consist of sample inlet, treatment chamber, high voltage pulse generator, control system and outlet for treated food products. Processing may be carried out in a static treatment chamber or in a continuous treatment chamber through a pump. The choice is dependent on scale of production. The static chamber is often sufficient for most

laboratory studies whilst the continuous chamber system is desirable for a commercial scale production.

Generation of pulsed electric fields requires a fast discharging of electrical energy through an electrical circuit system consisting of one or more power supplies with charging ability, switches, capacitors and resistors. The total power of the system is limited to the number of cycling times of the capacitors, that is, the charging and discharging in a given unit of time.

### 1.2.1. Pulsed Electric Field in Food Processing Technology

The PEF processing system can be illustrated by the schematic flow chart on **Fig. 1** for the OSU-6 commercial scale PEF system[5].

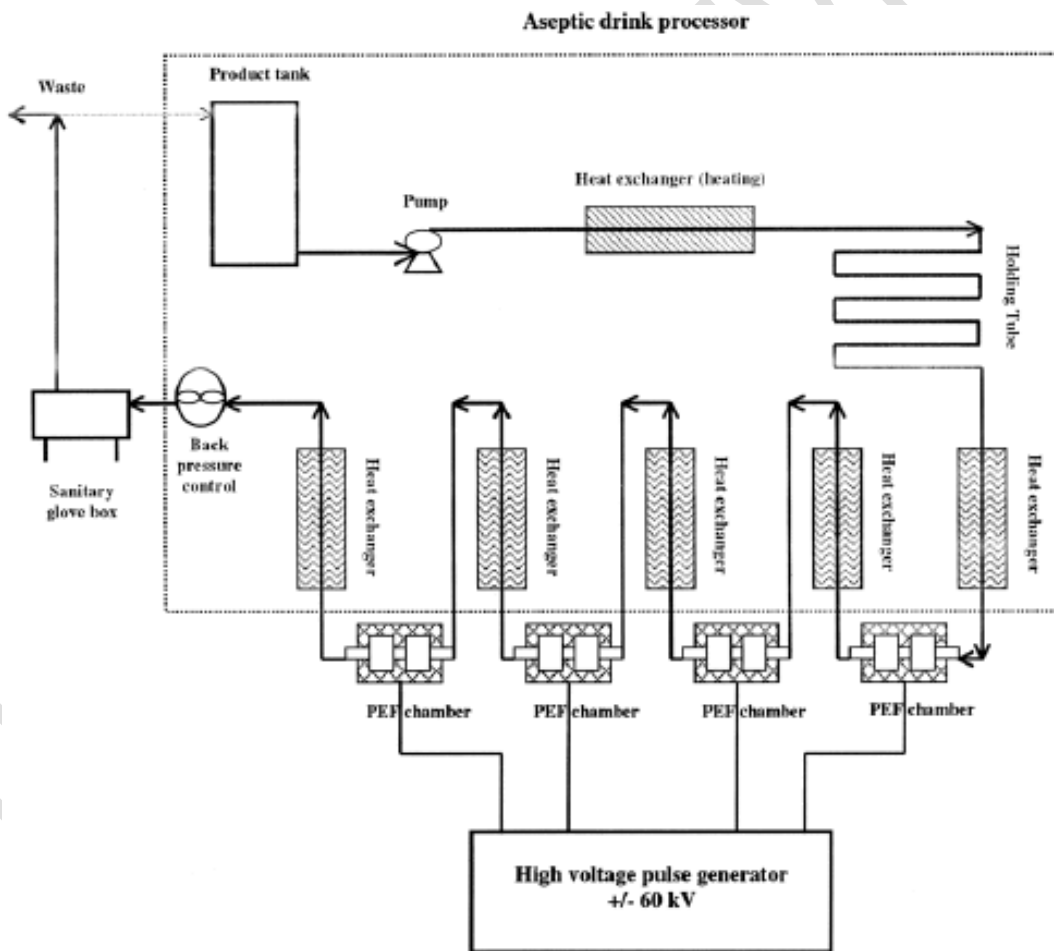

**Figure 1:** Flowchart of pulsed electric fields (PEF) processing system[5].

It consists of an aseptic drink processor, a high-voltage pulse generator and four tubular pulsed electric fields chambers. Production parameters are controlled and monitored in the aseptic drink processor. The temperature, pressure and production rate are regulated in the aseptic processor. Electric pulses can be applied in the form of constant square wave, increasing square wave, exponentiallydecaying wave, bipolar or oscillatory pulseswhich are generated in the high voltage pulse generator. Each of the tubular PEF chamber consist of two boron carbide tubular electrodes and a tubular insulator made of ceramic. Tubular diameter is typically in the range of 1.0cm and the distance between electrodes maintained at 1.270cm. Electrochemical parameters are preset depending on the type of food product. Typical parameters[12]. for a tomato juice PEF processing are peak current through each PEF chamber in the range of 50A to 75 A; electric field strength set at 40KV/cm for a pulse duration of 2 $\mu$ s, and a total PEF treatment time of 57 $\mu$ s. A tubular PEF chamber is shown **Figure2**. Recommendation for a liquid food product is centered mainly on three treatment chamber designs which include parallel plate electrodes, coaxial or collinear configurations of cylindrical electrodes as shown in **Figure 3**. This is a good example of a treatment chamber with a diameter of 60mm and a maximum treatment capacity of 5t/h shown in **Figure 2**.



**Figure 2.:** A continuous flow PEF treatment chamber with a diameter of 60 mm[12].

Several research groups around the world are working on PEF applications for food treatment and pilot scale equipment is available at Ohio State University, USA, Stork Food Systems, The Netherlands, Berlin University of Technology, Germany and the German Institute of Food Technology, Germany. As stated earlier, pulse generation is achieved by charging a

capacitor bank and discharging the stored energy across a high voltage switch into the treatment chamber.

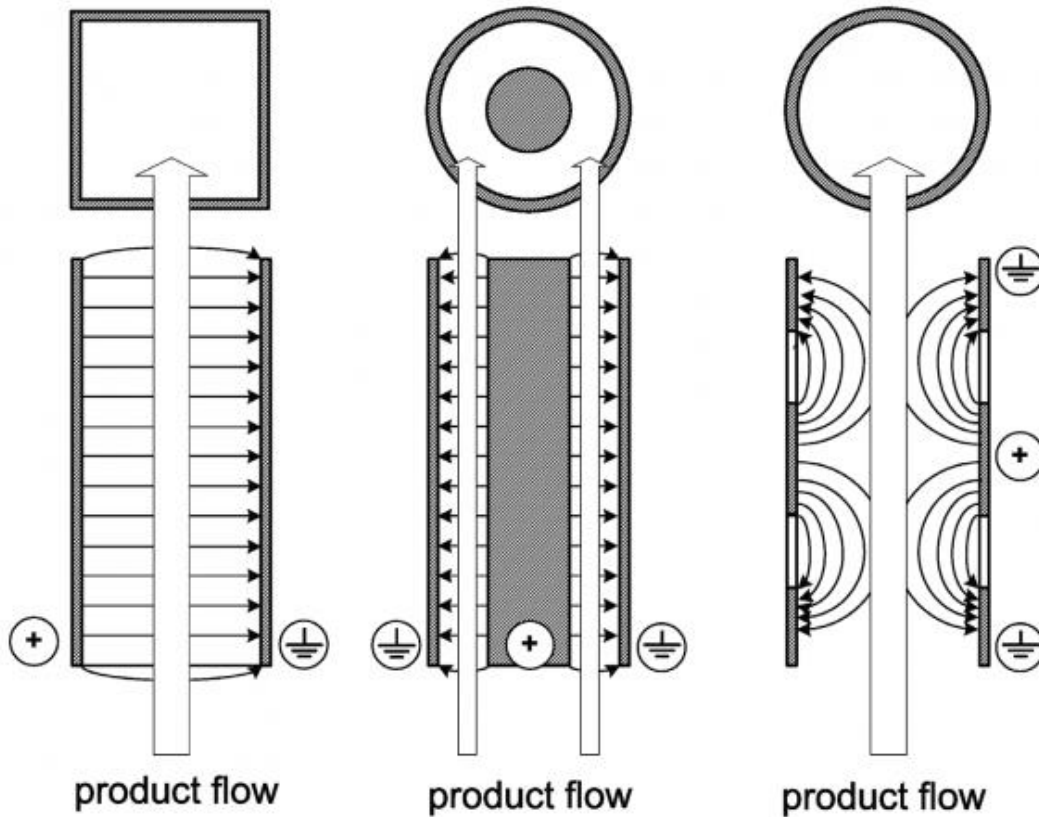

**Figure 3:** Different design configuration of internal PEF treatment chamber, (a) parallel plate configuration, (b) coaxial configuration and (c) collinear system[12].

The heat exchangers maintain inlet temperature at 45°C at the upstream of each PEF chamber. The food product in the PEF chamber then experiences a force per unit charge (electric field) which is responsible for the microbial cell membrane breakdown. The PEF processed food is cooled to 25°C through the chamber cooling system prior to packaging inside the sanitary glovebox. The food product is aseptically processed and packaged and stored under refrigeration at preset temperature. High current and high voltage probes are used to measure the voltage and current delivered to the tubular PEF chambers.

The PEF processing system can be summarized in a more simplified scheme as shown in which represents the basic components of a PEF system.

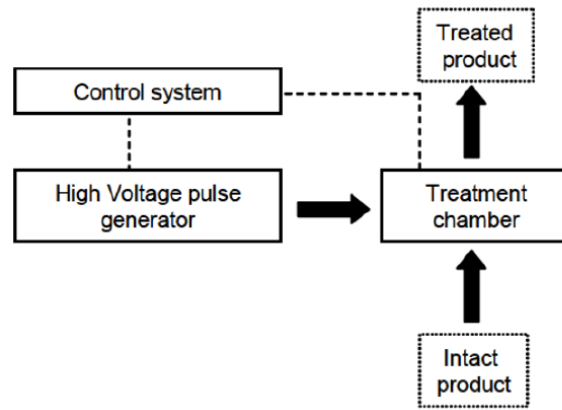

**Figure 4:** The basic components of PEF system

The basic components consist of product inlet, treatment chamber, high voltage pulse generator, control system and outlet for treated food. Food products may be processed in a static treatment chamber or in a continuous treatment chamber through a pump. The choice is dependent on scale of production. The static chamber is often sufficient for most laboratory scale studies whilst the continuous chamber system is desirable for a commercial scale production.

Generation of pulsed electric fields requires a fast discharging of electrical energy through an electrical circuit system consisting of one or more power supplies with charging ability, switches, capacitors and resistors. The total power of the system is limited to the number of cycling times of the capacitors. That is, the charging and discharging in a given unit of time. This is often expressed as the capacitance  $C_0$  of the energy storage device (capacitor) as given in the following expression:

$$C_0 = \tau/R = \tau\sigma A/d$$

Where  $\tau$  (S) is the duration of excitation pulse,  $R$  is the resistance ( $\Omega$ ),  $\sigma$  is the conductivity (S/m),  $d$  is the treatment gap (m) between electrodes and  $A$  is the electrode surface area ( $\text{mm}^2$ ).

The total energy stored in the capacitor is given by,

$$Q = 0.5C_0V^2$$

Where  $Q$  is the stored charge (energy) and  $V$  is the charge voltage. Storage capacitors are the main components of high-power sources. The capacitors which can assume the form of conventional capacitor, supercapacitor or pseudocapacitor generates electromagnetic fields whilst discharging stored energy. The electric fields accelerate charged particles of food during processing leading to thermal, chemical, mechanical and electromagnetic waves. The overall

effect is modification of food product at molecular level through mass and charge transport phenomena. Commonly applied excitation signals (washesapes) of PEF including square wave and exponentially decaying wave are shown on Fig. 5.

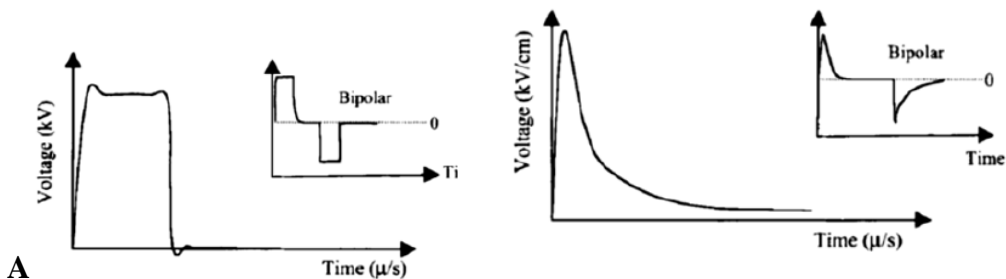

**Figure 5:** Excitation signals of PEF processing technology: A) square wave excitation signal and B) exponentially decaying wave excitation signal[12].

Desired electrical pulses are generated from high voltage pulse generator in accordance with preset parameters such as step pulse potential ( $\Delta E$ ), waveform, pulse duration and interval between pulses.

### 1.2.2. Other Electro-technologies for Food Processing

On the basis of keeping food processing below temperatures normally employed in thermal processing, several innovations have emerged over the years. The ultimate goal is geared towards optimizing the nutritional quality of food including vitamins, minerals and essential flavors. HHP subjects liquid or solid food product to pressures between 40,000 to 80,000 pounds per square inch (PSI) for duration of five minutes or less[10]. The high pressure is applied evenly to the food product in order to inactivate microorganism on the surface and interior of food product. This is accomplished by alteration of molecular structure of chemical compounds necessary for metabolic activity of microorganisms in food products. The HHP is highly effective against bacteria, molds, parasites and viruses. The technique requires a minimum amount of energy to compress solid or liquid seafood compared to 100°C processing temperature for thermal method. This technology offers several advantages over thermal processing including reduced processing time, retention of flavor, texture and freshness, minimal physical and chemical changes and reduced functionality operations[10]. High hydrostatic pressure units are in place in a number of juice and vegetable processors, oyster processing facility and meat

processing. Consumers of raw fish are particularly happy with this innovation that effectively reduced the risk associated with raw fish consumption.

The main components of HHP system are:

- 1) A pressure vessel generation system
- 2) A pressure vessel and its enclosure
- 3) A temperature control device and
- 4) Material handling system.

These components are depicted on Fig.6 below.

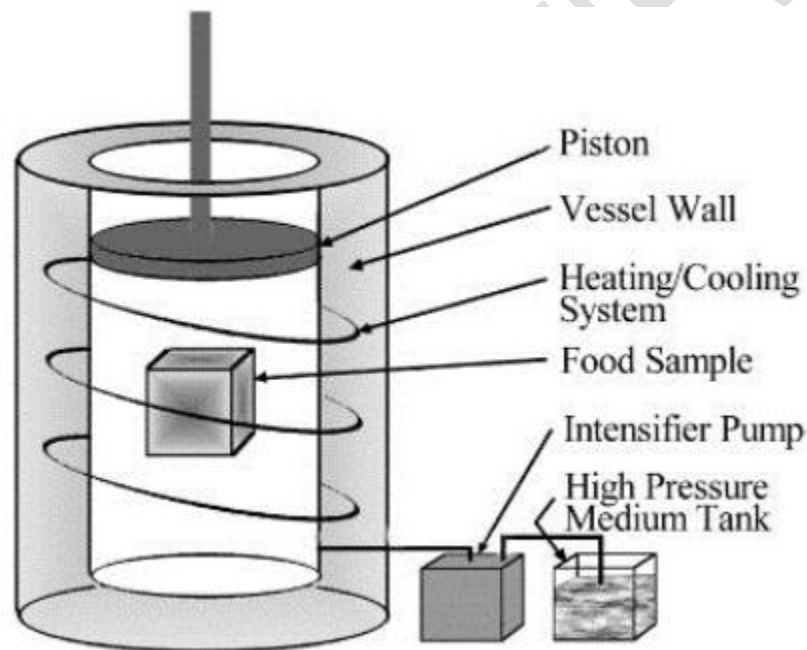

**Figure 6:** A high hydrostatic pressure system consisting of a pressure vessel, pressure generator, temperature control and food handling system[10].

A HHP system of 400 MPa at 20°C is reported to have significant inhibition on microorganism: 3 log reduction in the case of bacteria specie and 6 log reduction in the case of penicillium mold.

#### 1.2.2.1. Pulsed X-ray

Pulsed X-ray is another emerging electro-technology that utilizes a solid-state opening switch to generate high intensity electron beam X-ray pulses. Whilst electron have limited

surface penetration of ca. 5 cm, X-ray have significantly higher penetration up to 400cm from the surface depending on the energy source. Pulsed X-ray has been used in the inactivation of E.coli in meat product and completely eliminate salmonella from food.[13].

#### **1.2.2.2. Microwave Heating**

Microwave heating is another effective electro-technology that utilizes electromagnetic waves of certain frequencies to generate heat in food products. Applicable microwave frequencies are in the range of 2450MHz to 915MHz for pasteurization, sterilization or to simply improve food's digestibility[14]. It is based on the principle of orientation of polar molecules with dipole moments, such as water molecule, according to the alternating electromagnetic field upon absorption of microwave energy. The rotation of water molecules in food generate heat for food processing. In addition to water molecules, other ionic species in food product are accelerated by the magnetic fields to generate heat through collisions. Magnetron embedded in microwave system is a vacuum tube in which electrical energy from power supply is converted to an oscillating magnetic field. The technique is widely applicable to meat, fish, vegetable and other food products.

#### **1.2.2.3. High Intensity Light Pulse**

High intensity light pulse is a surface sterilization technology using broad spectrum of electromagnetic radiation from UV region (180nm) up to short intense pulses of near infrared (NIR) of wavelength around 1100nm. Pulse of light across the spectrum are emitted from one to twenty flashes per second[13]. This technique is highly effective in microbial reduction in meat and fish processing, reduction of Escherichia coli in juice processing and reduction of aerobic microbes in vegetables such as spinach, cabbage, lettuce and green bell pepper.

The key component of High Intensity light pulses is a flash lamp filled with an inert gas, such as Xenon, which emit broadband radiation from UV up to NIR. Application of high-current electrical pulses to the inert gas in the lamp cause collision between electrons and gas particles leading to excitation of gas molecules which on subsequent relaxation emit light of high intensity and short pulses (1 $\mu$ s to 0.1s). Antimicrobial effect of UV light has been attributed to cause of structural changes in DNA.

### 1.3. Shelf-life of Thermal and PEF Processed Food Products

The shelf –life of processed food product is a measure of several factors causing degradation of food product. The onset of such biological or physicochemical alteration in processed food is detrimental to the ultimate shelf-life of food product. Thus, a measure of microbial stability, lipoxxygenase activity, lycopene activity, viscosity and pH of processed food are important measure of shelf-life of food product[15]. These parameters were evaluated for thermally processed, PEF processed, and control juice product stored at various temperatures ranging from 4<sup>0</sup>C to 95<sup>0</sup>C. The shelf-life study was conducted for 112 days.

*Microbial Stability.* Juice without incubation was thermally processed or PEF processed for the shelf-life study. The initial total aerobic plate count and yeast and mold count of juice before thermal or PEF processing were established. The microbial stability was determined by using the same method for the microbial inactivation study.

*Lipoxxygenase Activity.* Lipoxxygenase activity can be measured according to standard methods [13].

*Lycopene Analysis.* Analysis of hexane extract obtained using standard method [15].

*Ascorbic Acid Analysis.* The concentration of ascorbic acid in juices can be measured following the procedure described [15], [16] using an HPLC system.

*Particle Size Distributions.* Analysis of particle size of juices can be carried out by Particle size Mastersizer (Malvern Instruments, Inc.). A computer equipped with Mastersizer (Micropulus 2.15 Malvern Instruments, Inc.) recorded distribution of the particle size of juice products.

*pH.* The pH of tomato juice was measured using a pH meter at room temperature.

*Viscosity.* The viscosity of juice products can be measured by using a Brookfield viscometer. Viscosity determined at room temperature and 4 rpm.

1. The effect of storage on these biological and physicochemical markers are expressed on **table 1** for a control sample, thermally treated and PEF processed juice product.

Parameter	Days	Control	Thermally processed	PEF processed
<i>Microbial stability (logcfu/ml)</i>	112	5	2	3
<i>Lipoxxygenase activity</i>	112	100% @ 30 d	Below detection limit	20%

<i>Lycopene Analysis mg/100g</i>	112	ND	4.08%	5.73%
<i>Ascorbic acid</i>	60	40% @ 30dND	20%	10%
<i>Particle Size (µm)</i>	112	277.08	281.11	273.32
<i>pH</i>	112	4.33	4.27	4.30
<i>Viscosity(mPa)</i>	112	42	42	42

**Table1:** Comparison of microbial activity, lycopene, lipoxygenase, ascorbic acid, pH and viscosity at 4°C storage for 112 d for thermally processed, PEF processed and controlled sample[15].

The initial total aerobic plate count of the control hot break juice at 0 day was 10 CFU/mL (0 day). Both PEF and thermally processed juices had <10 CFU/mL (0 day). The number of total aerobic microorganisms in thermally processed juice was <100 CFU/mL during storage at 4°C. The number of total aerobic microorganisms of PEF processed juice was <1.0 × 10<sup>4</sup> CFU/mL during storage at 4°C for 112 d, whereas that of control juice reached 1.0 × 10<sup>5</sup> CFU/mL at 4°C after 49 d [15]. Control juice was not sampled after 49 d due to the gas formation by multiplied microorganisms. The high rate of microbial growth in PEF processed juice than in thermally processed juice during storage may be due to the relatively lower inactivation of the spores by PEF and the germination of the surviving spores during storage. Spores of *Bacillus*, molds and yeasts were detected from the PEF processed juice by microscopic examination. Most studies reported that PEF does not efficiently inactivate bacterial spores [17], [18]. Little or no effect of PEF on the inactivation of mold. A high number of spores of *Bacillus* and ascospores of molds and yeasts probably survived in PEF processed juice than in thermally processed juices so that there was more growth of microorganisms in PEF processed juice than in thermally processed juice. PEF processing can be effective for microbial inactivation, extending the shelf life of foods, but not for complete disintegration of microorganisms including spores [18]. PEF technology does not inactivate enzymes to the extent of thermal processing.

The lipoxygenase activity is irreversibly inactivated during thermal and PEF processing. Most important flavor in juice products are impacted by lipoxygenase activity. This includes such compounds as hexanal, cis-hexenal, trans-2-hexenal, hexanol and tran-2-hexenol. Pulsed

electric field processed juice possesses a better flavor than thermally processed juice due to activity of residual lipoxygenase compounds.

Ascorbic acid decreased significantly after thermal processing compared to pulsed electric field processing. Thermal processing causes considerable loss of ascorbic acid due to the higher processing temperature which accelerate chemical reactions in food leading to loss of ascorbic acid. The higher retention of ascorbic acid in thermally processed juice is attributed to the low temperature of processing in PEF technology. Minimization of Oxygen I the headspace of package and oxygen permeation through the package is essential for minimal oxidative degradation of ascorbic acid thus, food flavor and color characteristics[15]. Higher concentrations of ascorbic acid can be achieved over a prolong storage period through proper selection of packaging material and flushing the processed food product with an inert gas such as nitrogen just prior to packaging since loss of ascorbic acid increases with increasing storage period irrespective of processing method[15].

#### **1.4. Sensory Properties of Thermally and PEF processed Food products**

The sensory attributes of food product consist of flavor, color, appearance, texture and overall acceptance by consumers. These properties are often evaluated by some panelist from 20 up to 60-member panel. The pane may be trained or untrained in food testing and may simply consist of students or faculty members. The sensory evaluation may be carried out on freshly prepared food product (thermally and non-thermally processed) or stored for specified period of time to confirm the absence of some microorganisms. The panelistswere asked to rate the preference of appearance, color, texture, flavor and overall acceptability by marking on a horizontal line corresponding to the amount of the perceived stimulus. A hedonic scale[15] of 1-9 may be used for each attribute, where a higher number represents higher preference of attribute.

It is usual to test the statistical significance in the differences of data between thermally processed and PEF processed food products. There was a reported significant differences in flavor and overall acceptability[15] between thermally processed and PEF processed tomato juices( $p < 0.05$ ).The panel scored 6.2 for flavor (PEF processed) and 4.7 for thermally processed tomato juice. Also, overall acceptability was 4.8 for thermally processed juice and 6.2 for PEF processed juice. The higher number indicating a higher preference for PEF processed juice. The

higher flavor intensity of PEF processed juice compared with thermally processed juice was related to the higher activity of lipoxygenase of PEF processed tomato juice[15], [16], [18].

### 1.5. Applications of Pulsed Electric Field Food Processing Technology

Potential applications of PEF cuts across all facets of food processing industries. Several food processors are taking advantage of this PEF technique to enhance extraction of intracellular compounds from fruits and vegetables; to improve drying rates of carbohydrates such as yam, cassava, potatoes and meat products; and gentle decontamination of liquid foods including orange juice, grape juice, tomato juice and dairy products[19]. An overview of potential applications of PEF processing technology in food and bioprocessing industries is shown in Figure 5.

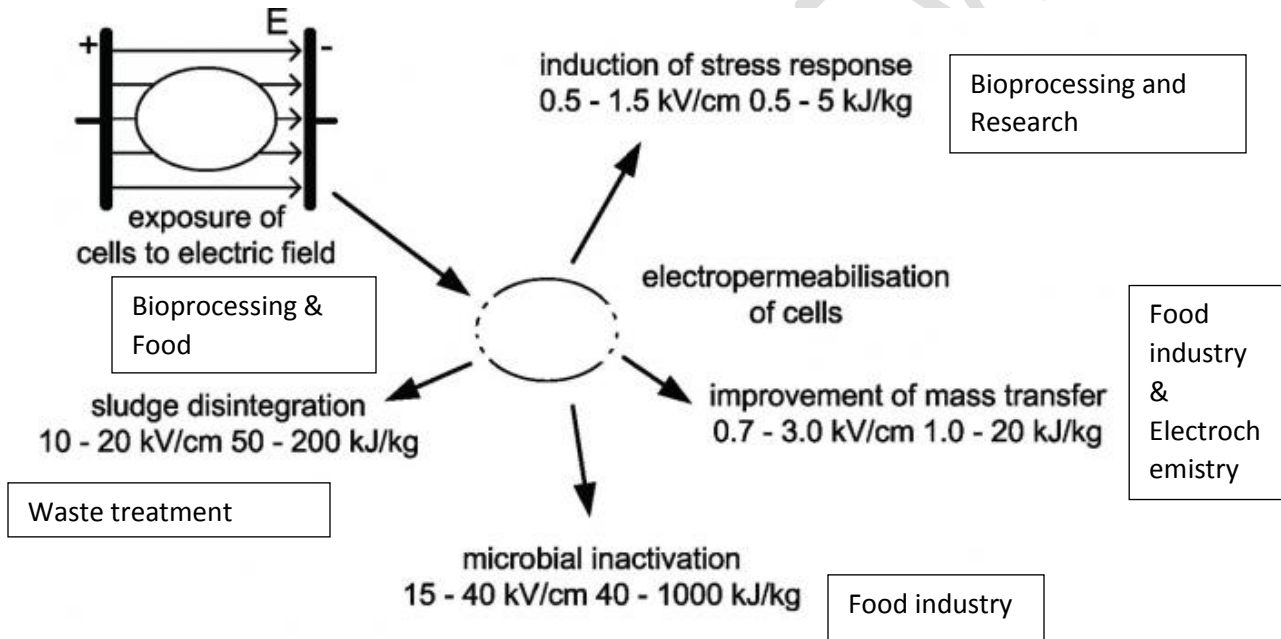

**Figure 7:** Applications of PEF in food, bioprocessing, waste treatment and research industries

Cell disintegration is often a crucial prerequisite prior to liquid-solid separation during extraction of fruit and vegetable juices. Conventionally, an enzymatic maceration is applied, requiring residence times of 30 to 60 minutes and holding tanks[19]. With the application of PEF technology food processing residence time was extensively reduced to microseconds or some few seconds under continuous PEF treatment to induce cell disintegration in juice and vegetables. Dependent on apple variety and PEF treatment intensity, an increase in juice yield

was found, similar or higher than after an enzymatic treatment. A specific energy input of 3kJ/kg was sufficient to achieve an increase in juice yield. An advantage of this PEF food processing technology over thermal systems is that PEF technology does not cause a depolymerisation or de-esterification of hydrocolloids. The first industrial prototype for this application was installed in a German fruit juice producing company in 2006.

The PEF technology has dramatically improved drying time in the drying of foodstuffs. Drying often significantly contributes to production costs and time requirements due to limited moisture diffusion from product core to its surface. PEF can significantly improve water removal from product surface under various drying conditions, but high removal will cause the formation of a dry crust inhibiting further moisture supply. Improvement of drying several fruit and vegetable products using a PEF food processing technology has been shown, allowing for a reduction of drying times of up to 30 per cent for potato [6], [9]. The PEF technique has also improved production of dry cured ham and sausages requiring the application of gentle drying conditions. Typical drying times is in a range of up to 30 days. The potential to enhance drying rates of dry cured ham was investigated by subjecting samples of pork shoulder to a treatment at a field strength of 3 and 4kV/cm and a specific energy input of 5 and 20kJ/kg. Shortest drying times were achieved after a PEF treatment and brine injection, emphasizing the PEF technique's potential to improve moisture transport in meat tissues[19]. Significant energy savings can be expected due to faster moisture transport and increased production capacities of existing lines[10].

Induction of membrane pores by PEF can also be utilized in food preservation through inactivation of microorganisms. Loss of membrane barrier function and leakage of intracellular liquid cause cell death. This is often referred to as cell membrane permeabilization which can be visualized using fluorescent cell staining and flow cytometric analysis via the use of propidium iodide (PI) and carboxy-fluorescein (cF) for cell staining and cytometric analysis respectively. Propidium iodide is a membrane-impermeant probe which will not penetrate cells with intact membranes. After a PEF-treatment, PI diffuses into and stains the cells. The second probe, cF, is used primarily for the evaluation of cellular enzymatic activity. Dependent on number of pulses applied, membrane permeabilization increases, whereas cellular esterase activity is maintained in contrast to a thermal treatment at 95°C. Successful inactivation of 5 to 7 log cycles of microbial cells has been shown in tap water, fruit juices, milk and cream and beer as well as vitamin

solutions or nutrient media[19]. It is noteworthy that a PEF treatment is only effective on vegetative organisms, whereas spores, viruses or enzymes are mostly unaffected by the pulse electric field treatment technology, as the primary target (cell membrane) is missing. Process variables to improve energy efficiency are electric field strength, specific energy input and treatment temperature. Combining application of PEF and mild heat a microbial inactivation can be achieved with a low consumption of electrical energy while operating at lower maximum temperature and residence time in comparison to thermal processing[14]. Products are distributed while chilled to prevent degradation by residual enzyme activity. Retaining enzyme activity which is a potential disadvantage during juice processing by PEF technology might be an advantage in media where a microbial decontamination is desired, but preservation of enzyme or prevention of protein denaturation is important such as the production of raw milk cheese and treatment of enzyme or protein preparations of egg yolk where a reduction of microbial load could be performed without heat application and related changes in protein structure. It was shown that activity of lipid peroxidase, a component of native antimicrobial system can be retained after a microbial decontamination of milk[17]. A reduction of maximum temperatures during decontamination of liquids containing proteins could also help to minimize fouling at heat exchanger surfaces, and thus preservation of food flavor. In order to maintain their competitiveness, these facts have led to the wineries of traditional wine production zones as Europe to introduce new production technologies in an attempt to obtain high quality wines. The use of pulse electric fields technology that are able to enhance polyphenol extraction during red wine making may represent an important alternative to traditional techniques.

The potential of PEF technique to achieve disintegration of plant, animal or microbial cells has been shown, pre-treatment of tissue prior to extraction or drying and preservation of premium, chilled products or media containing proteins have been identified as promising applications. The technique can be scaled up to industrial size as demonstrated in many food industries in the US, Germany and around the world

## **1.6. Conclusion**

Thermal processing strongly affects the sensory attribute and some physicochemical properties of food products including loss of freshness, flavor, texture, color and appearance.

Pulsed electric fields processing and other innovations in electro-technologies of food processing such as high hydrostatic pressure, high intensity pulses, microwave and oscillating magnetic fields are able to inactivate microorganisms at ambient or sub lethal temperatures. These non-thermal processes have gained tremendous preference for their inherent capability of preserving nutritional values of food and fresh-like characteristics.

## References

- [1] M. Mohamed and A. Eissa, "Pulsed Electric Fields for Food Processing Technology," *Struct. Funct. Food Eng.*, p. 32, 2012.
- [2] G. A. Evrendilek, T. Baysal, F. Icier, H. Yildiz, A. Demirdoven, and H. Bozkurt, "Processing of Fruits and Fruit Juices by Novel Electrotechnologies," *Food Eng. Rev.*, 2012.
- [3] S. Min, G. A. Evrendilek, and H. Q. Zhang, "Pulsed electric fields: Processing system, microbial and enzyme inhibition, and shelf life extension of foods," *IEEE Transactions on Plasma Science*, vol. 35, no. 1, pp. 59–73, 2007.
- [4] H. Vega-Mercado *et al.*, "Non-thermal food preservation: Pulsed electric fields," *Trends Food Sci. Technol.*, vol. 8, no. 5, pp. 151–157, 1997.
- [5] U. Zimmermann, "Electric field-mediated fusion and related electrical phenomena," *BBA - Reviews on Biomembranes*, vol. 694, no. 3, pp. 227–277, 1982.
- [6] S. Sastry, "Ohmic heating and moderate electric field processing," *Food Sci. Technol. Int.*, vol. 14, no. 5, pp. 419–422, 2008.
- [7] S. Y. Ho, G. S. Mittal, and J. D. Cross, "Effects of high field electric pulses on the activity of selected enzymes," *J. Food Eng.*, vol. 31, pp. 69–84, 1997.
- [8] Y. Q. Li, Q. Chen, X. H. Liu, and Z. X. Chen, "Inactivation of soybean lipoxygenase in soymilk by pulsed electric fields," *Food Chem.*, vol. 109, no. 2, pp. 408–414, 2008.
- [9] D. Baines and R. Seal, *Natural Food Additives, Ingredients and Flavourings*. 2012.
- [10] V. M. Balasubramaniam and D. Farkas, "High-pressure food processing," *Food Sci. Technol. Int.*, vol. 14, no. 5, pp. 413–418, 2008.
- [11] B. R. Thakur and P. E. Nelson, "High-pressure processing and preservation of food," *Food Rev. Int.*, vol. 14, no. 4, pp. 427–447, 1998.
- [12] M. E.A. and A. H. Amer Eiss, "Pulsed Electric Fields for Food Processing Technology," *Structure and Function of Food Engineering*. 2012.

- [13] N. K. Rastogi, "Application of high-intensity pulsed electrical fields in food processing," *Food Rev. Int.*, vol. 19, no. 3, pp. 229–251, 2003.
- [14] S. Chandrasekaran, S. Ramanathan, and T. Basak, "Microwave food processing-A review," *Food Research International*, vol. 52, no. 1, pp. 243–261, 2013.
- [15] S. Min, Z. T. Jin, and Q. H. Zhang, "Commercial scale pulsed electric field processing of tomato juice.," *J Agric Food Chem*, vol. 51, no. 11, pp. 3338–3344, 2003.
- [16] S. Toepfl, "Pulsed Electric Field food treatment - scale up from lab to industrial scale," *Procedia Food Sci.*, vol. 1, pp. 776–779, 2011.
- [17] C. Siemer, S. Toepfl, and V. Heinz, "Inactivation of *Bacillus subtilis* spores by pulsed electric fields (PEF) in combination with thermal energy II. Modeling thermal inactivation of *B. subtilis* spores during PEF processing in combination with thermal energy," *Food Control*, vol. 39, no. 1, pp. 244–250, 2014.
- [18] T. Tanino, T. Yoshida, K. Sakai, S. Bing, and T. Ohshima, "Inactivation of *Escherichia coli* phages by PEF treatment and analysis of inactivation mechanism," *J. Electrostat.*, vol. 73, pp. 151–155, 2015.
- [19] F. Donsì, G. Ferrari, and G. Pataro, "Applications of pulsed electric field treatments for the enhancement of mass transfer from vegetable tissue," *Food Eng. Rev.*, vol. 2, no. 2, pp. 109–130, 2010.