

A Novel Filter Tundish towards Improving Quality and Yield of steel for Single Strand Slab Casting

Short communication

abstract

The present study highlights about novel Filter Tundish towards Improving Quality and Yield of steel for Single Strand Slab Casting. Tundish is such an important metallurgical vessel like BOF, EAF, Ladle, VOD, RH-degasser etc. which act as a pivotal role to improve the plant performance by reducing grade transition product or transition slab, increasing floatation of detrimental inclusions towards cleanliness of liquid steel and eliminating contaminations of melt from emulsifications etc. Researchers were tried to developed many models to predict the transition slab amount with changing different operating parameters so that casting operators can reduce the amount of transition grade. Numerical investigations by ANSYS FLUENT software is required to see the insight. Same time physical modeling study by using water modeling experimental set up is required to judge validity of the numerical results with experimental investigations.

Keywords: ANSYS FLUENT, metallurgical vessel, RH-degasser, novel Filter Tundish

Background of the Study

In 21st century steelmakers are facing a competitive market due to globalization as well as for increasing number of steel producers over the world. So there is an increasing demand to supply of clean steel to the customers at low cost. In this regard reduction of metal loss as well as less inclusions containing steel production are very vital for steel manufacturers to cope with the international market. Tundish is such an important metallurgical vessel like BOF, EAF, Ladle, VOD, RH-degasser etc. which act as a pivotal role to improve the plant performance by reducing grade transition product or transition slab, increasing floatation of detrimental inclusions towards cleanliness of liquid steel and eliminating contaminations of melt from emulsifications etc. [1]. To reduce generation of transition slab amount and improving the steel quality by lowering percentage of large or medium size inclusions, over the last 3 decades researchers had made many modifications of tundish geometry as well as optimizations of flow control refractory's [2]. 2-4 transition slabs are downgraded by quality control department during grade mixing. These transition slabs can be used only for internal purposes. Simultaneously medium and large size inclusions create defects in slab as well as hot rolled coil. Blow holes, sliver are the primary defects in the slabs and hot rolled coil. The customers of the hot rolled coil make many components from this

sheet product after deformation during which some serious components failure takes place from inclusions. Clogging of the submerged entry nozzle is frequently happen in steel melting shop during continuous casting of liquid steel due to blocking of the nozzle from inclusions build up. So, numerous studies are required to combat those phenomenons in the steel plants towards improving the yield and quality of steel.

Grade Intermixing

Grade mixing can be reduced by optimization of tundish liquid steel flow by using various flow control refractories like dam weir arrangements. **Figure 1 (a)** is showing actual as well computational results of grade transition time for a typical 45 ton twin strand slab casting tundish. **Figure 1(b)** shows that grade transition is highly concentrated at the center of the slab than surface of the slab. It is also saying a loss of 27 tons slab from grade transition effect. Early some researchers found that the use of double dam and weir can reduce the amount of transition slab in substantial amount [3]. A typical schematic of double dam weir arrangements is depicted in the **Figure 1 (c)**. It is observed that maximum 35 tons of transition slab generations can be reduced by using double dam weir arrangements with low level of liquid steel during grade transition time in comparison no flow control with full liquid steel level during unsteady period as exhibited in the **Figure 1 (d)**.

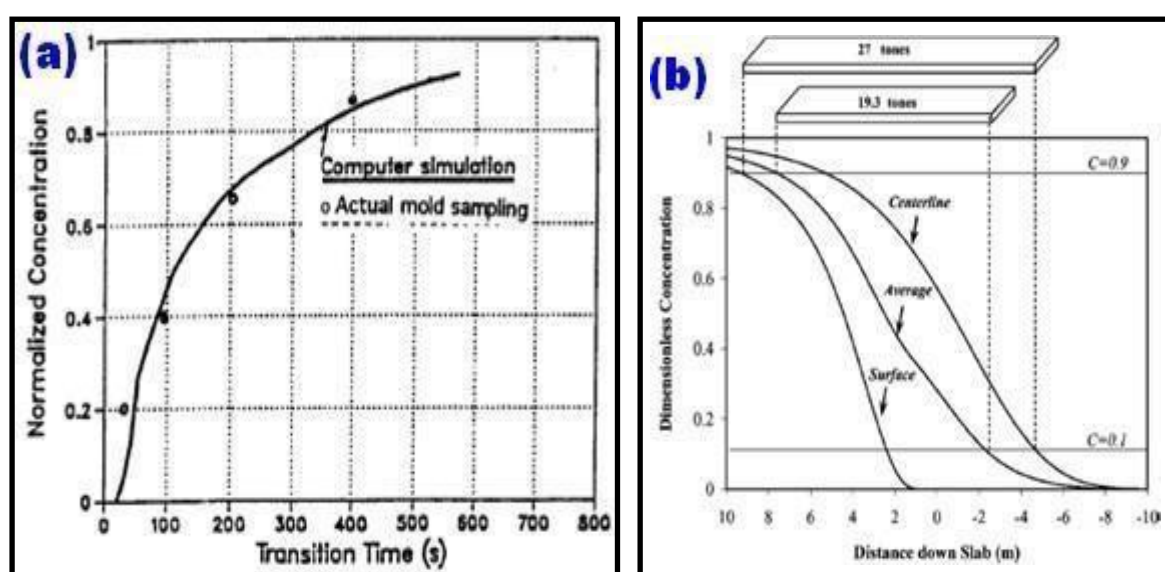

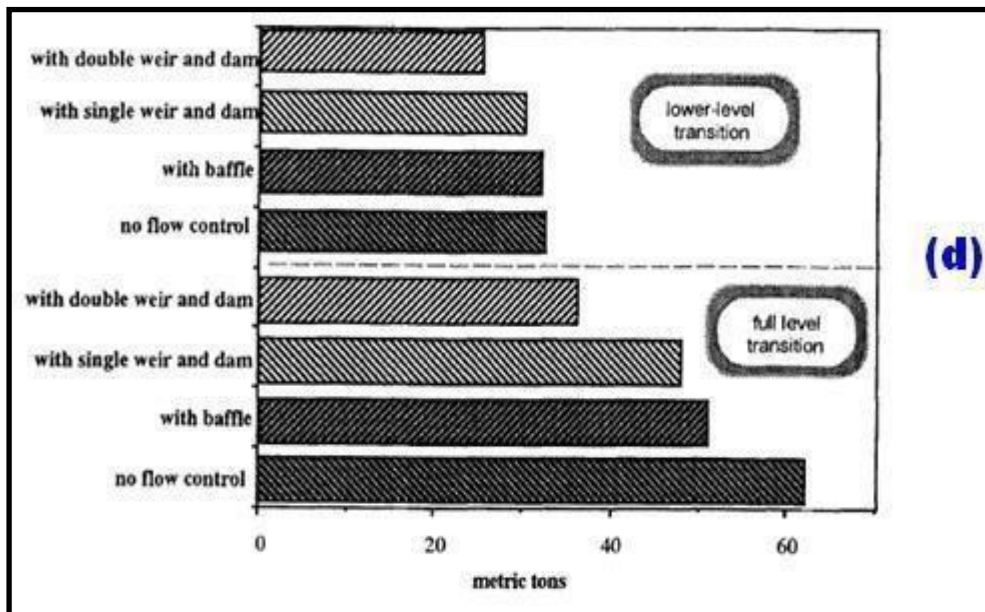
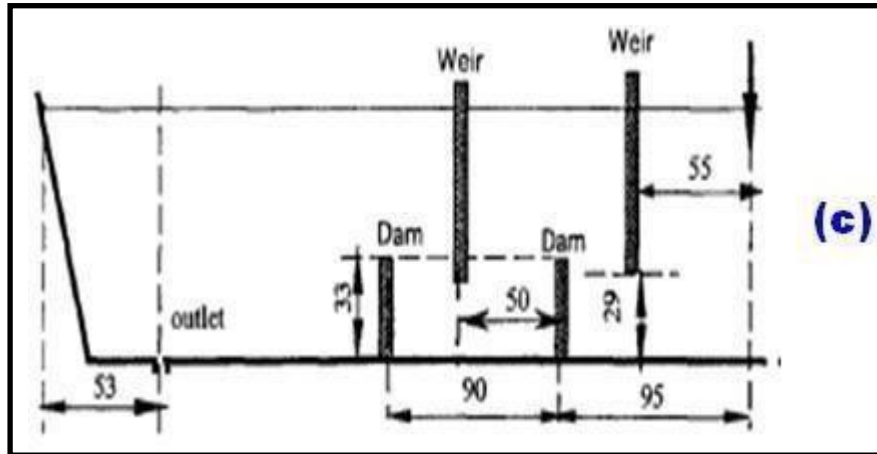
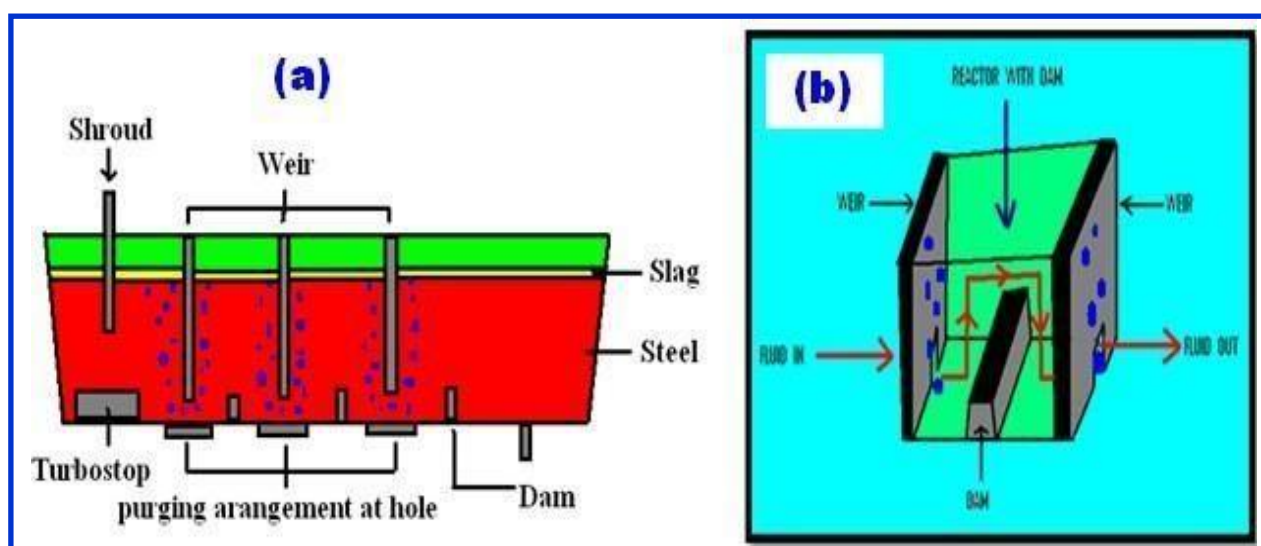

Figure 1 (a) Grade Transition in 45 ton Twin Strand Slab caster (b) Variation of mixed grade along slab length and width (c) Double weir-dam arrangement for reducing transition slab (d) Amount of reduction transition slab at various tundish operations [3-4].

Not only slab caster grade intermixing is a serious problem of round bar four line caster where some researchers have used numerical tool to reduce the effect of grade transition [5]. Researchers were tried to developed many models to predict the transition slab amount with changing different operating parameters so that casting operators can reduce the amount of transition grade [6-7]. Due to very high temperature of the liquid steel it is not possible to see the insights of the liquid steel flow within the tundish reactor. So many investigations over the decade have been carried out in laboratory scale by CFD analysis as well as physical modeling by tracer injection to optimize the flow within the tundish to minimize the grade mixing during unsteady state operation [8-12].

It is observed that in all respect the use of double weir dam is effective to reduce the transition slab in slab caster towards improving the efficiency of steel melt shop.

Recently the author have developed a novel concept “Multi reactor with argon purging” where a special type of weir and dam have been used sequentially with argon purging at the hole of the special wear to reduce more the amount of transition slab as well as increasing the floatation’s of inclusions towards improving the quality of liquid steel as shown in the Figures 2 (a) and (b) [13]. This is basically a novel multi reactors arrangement with dam and argon injection at hole of special weir instead off chamber + dam arrangement which earlier researchers are patented. The grade mixing CFD study by ANSYS FLUENT were compared in Figures 2 (c) and (d) which shows that multi reactor with argon purging tundish is much more effective than normal tundish without flow control to minimize the mixing of dissimilar grades. Graphical plot in Figure 2 (e) shows that this novel tundish is highly effective to reduce grade mixing than any other tundish with some flow control arrangements. So it suggests that this technology is very useful to improve the yield of tundish by less amount generation of transition slab.



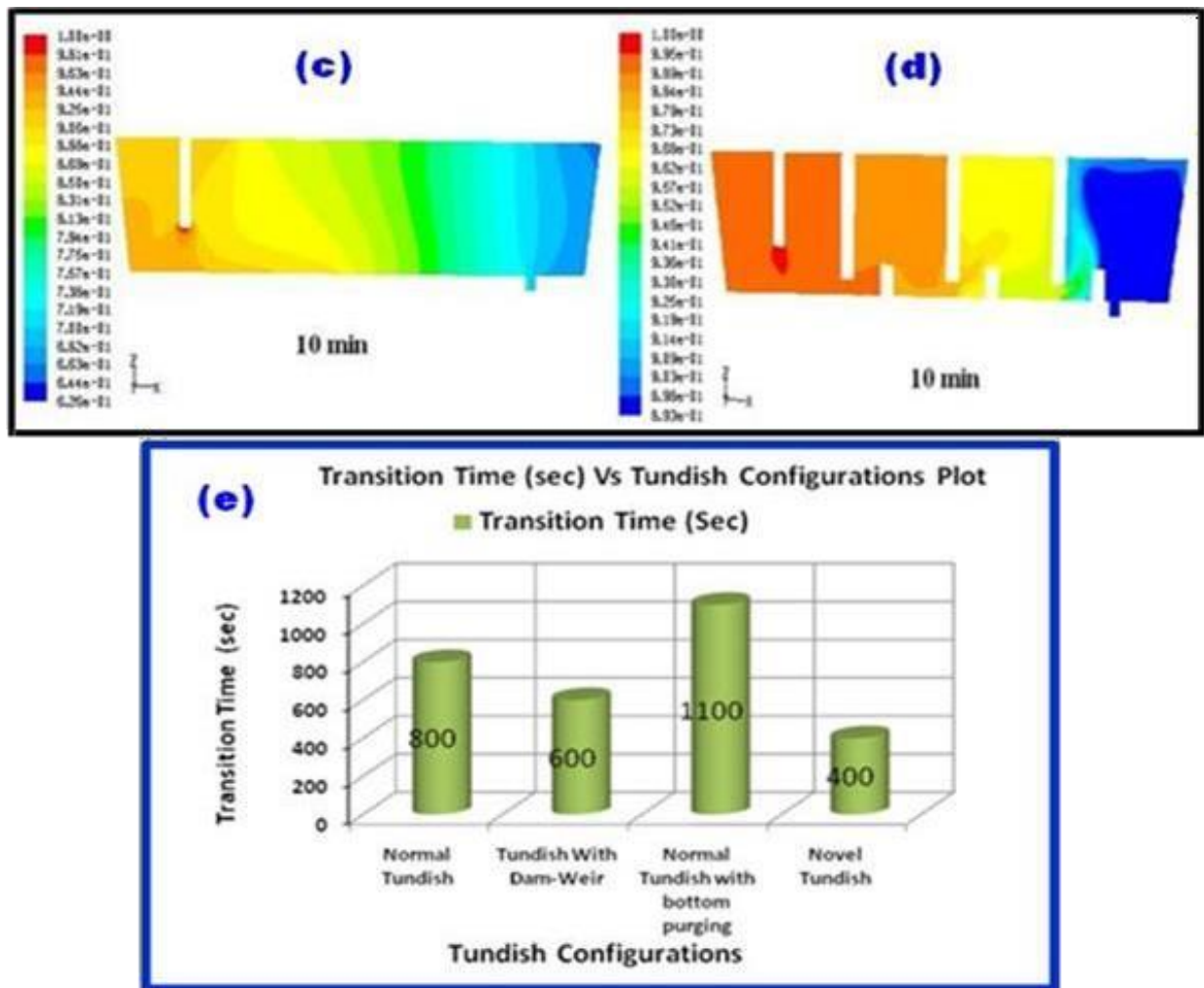
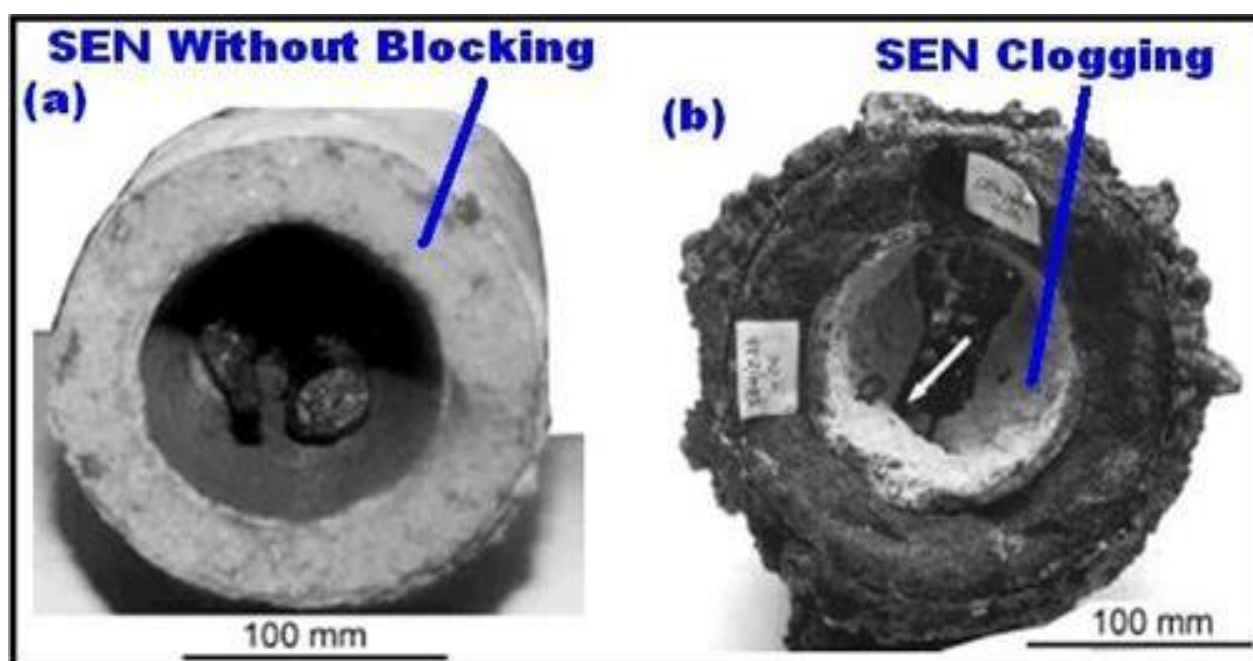

Figure 2 (a) Schematic of Multi Reactor Tundish with Argon Purging, (b) Schematic the reactor arrangement, (c)Grade mixing contour for Normal tundish without flow control refractory, (d) Grade mixing contour for Novel Multi Reactor tundish with argon purging, (e) Transition time plot of different tundish configurations along with Novel Multi Reactor Tundish with argon purging [13].

Removal of Inclusions

There is over increasing demand of production stringent clean steel by steelmaker inducing improving the floatability of alumina inclusions in tundish which act as a buffer between ladle and mold. Because inclusions have detrimental effect on product as well as hamper the normal casting process by premature blocking the submerged entry nozzle. **Figures 3 (a) and (b)** shows the submerged entry nozzle without clogging and with clogging by Alumina inclusions [14]. **Figures 3 (c) and (d)** are exhibiting the scanning electron micrograph images of cluster of alumina inclusions in low carbon aluminum killed steel as well as generation of voids from alumina inclusions during deformation of the semi-finished product [15-16]. This voids can generate detrimental cracks if exceed some certain size range. **Figures 3 (e) and (f)** are showing formation of serious sliver defects from alumina inclusions in stainless steel slab and hot rolled coil [16]. The sliver defects generate due to tearing off metal from coil surface which sometimes create cracks in the final product of the customer. So inclusions removal and clean steel production is very prime importance of the steelmaker over many years.



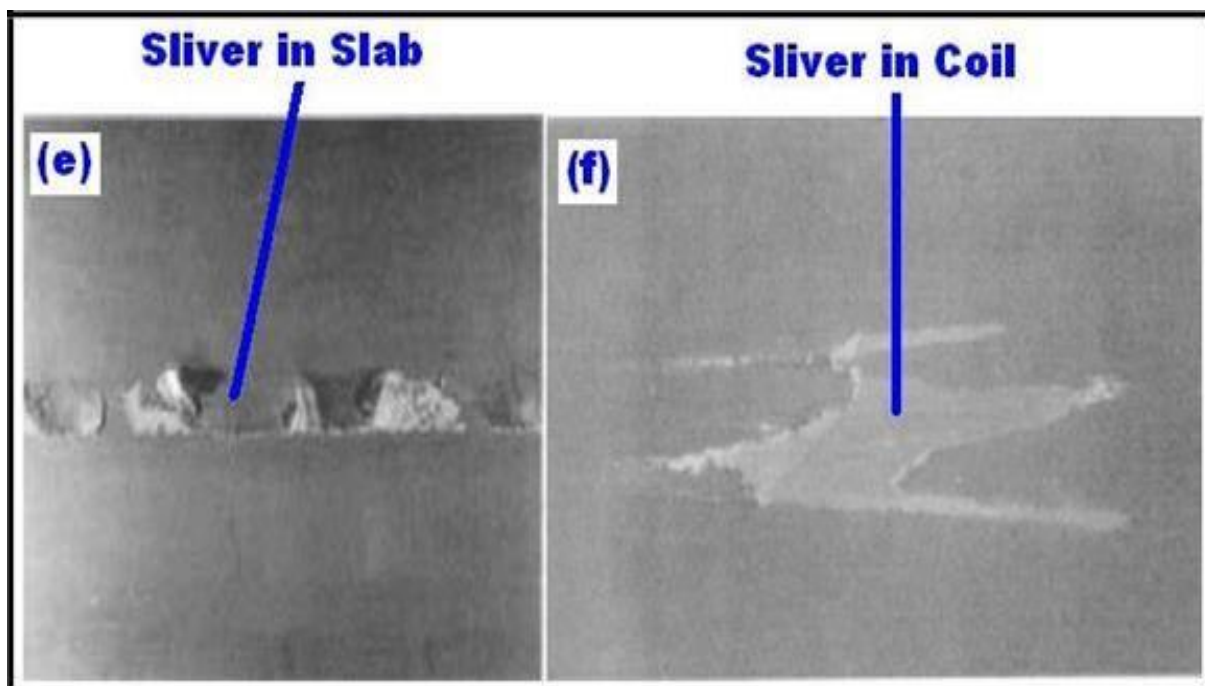
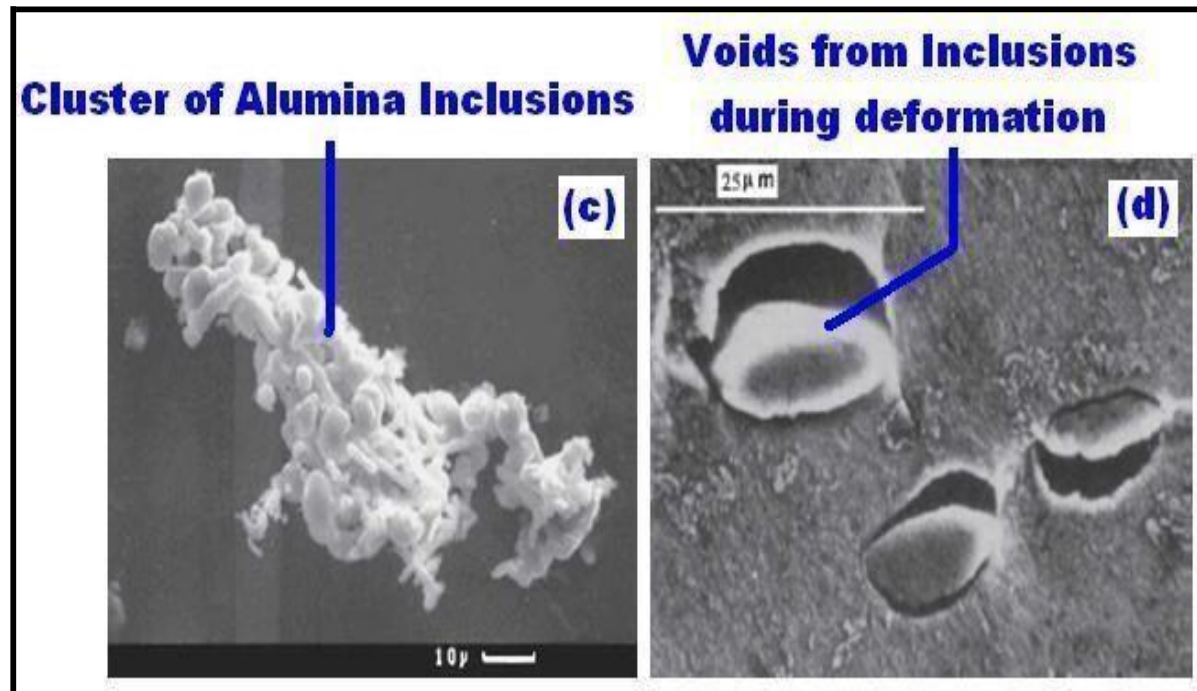
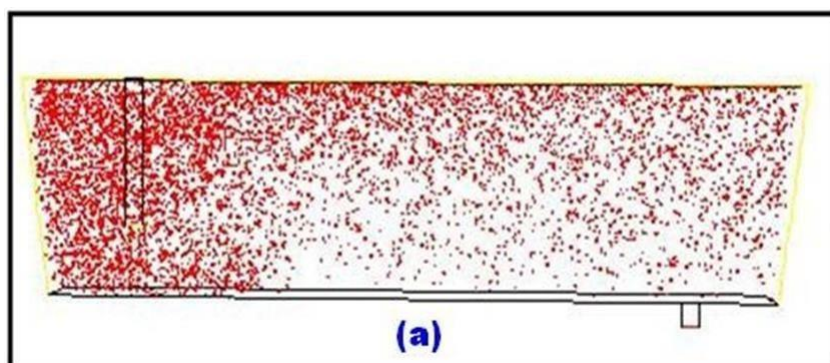

Figure 3 (a) SEN without clogging (b) SEN with clogging (c) SEM image of alumina inclusions cluster (d) Voids from alumina inclusions in LCALK steel (e) Sliver in slab (f) Sliver in Hot rolled coil [15-16].

To study laboratory scale investigation for enhancing the inclusion floatation several flow control refractory's arrangements were made within tundish and it was found that the incorporation of dam and weir as well as its suitable arrangements has great effect on inclusion floatation in tundish [17-19]. As steel cleanliness is very important for steelmakers, new concepts were used in steel plants to remove inclusions from liquid steel in tundish. Researchers had developed new tundish like "Centrifugal Flow Tundish" and "Swirling flow tundish" towards removing inclusions by inducing centrifugal force to separate inclusions from steel melt [20-21]. Those tundish is very helpful for deoxidizations but limited scope to float inclusions below 100 μm as well as prolonged transition period in tundish adversely affects the yield of caster [22-23]. In this regard researchers have focused on better steel slag interaction so that inclusions can be trapped within the slag phase [24]. It was revealed by researchers that instead of trough type tundish double weir and double dam tundish is much more effective to better removal of inclusions in tundish [25]. Argon purging in normal tundish as well as H shaped tundish just below normal weir were introduced to separate inclusions from steel melt [26-27].

But it is observed that argon purging in normal tundish increase the transition time and single only weir argon purging arrangement is not so much effective to remove inclusions substantially and on the other hand author found that multi reactor with argon purging is highly capable than any other flow control arrangement to remove large amount of inclusions from tundish melt as observed from Figures 4 (a), (b), (c) and (d) [13].



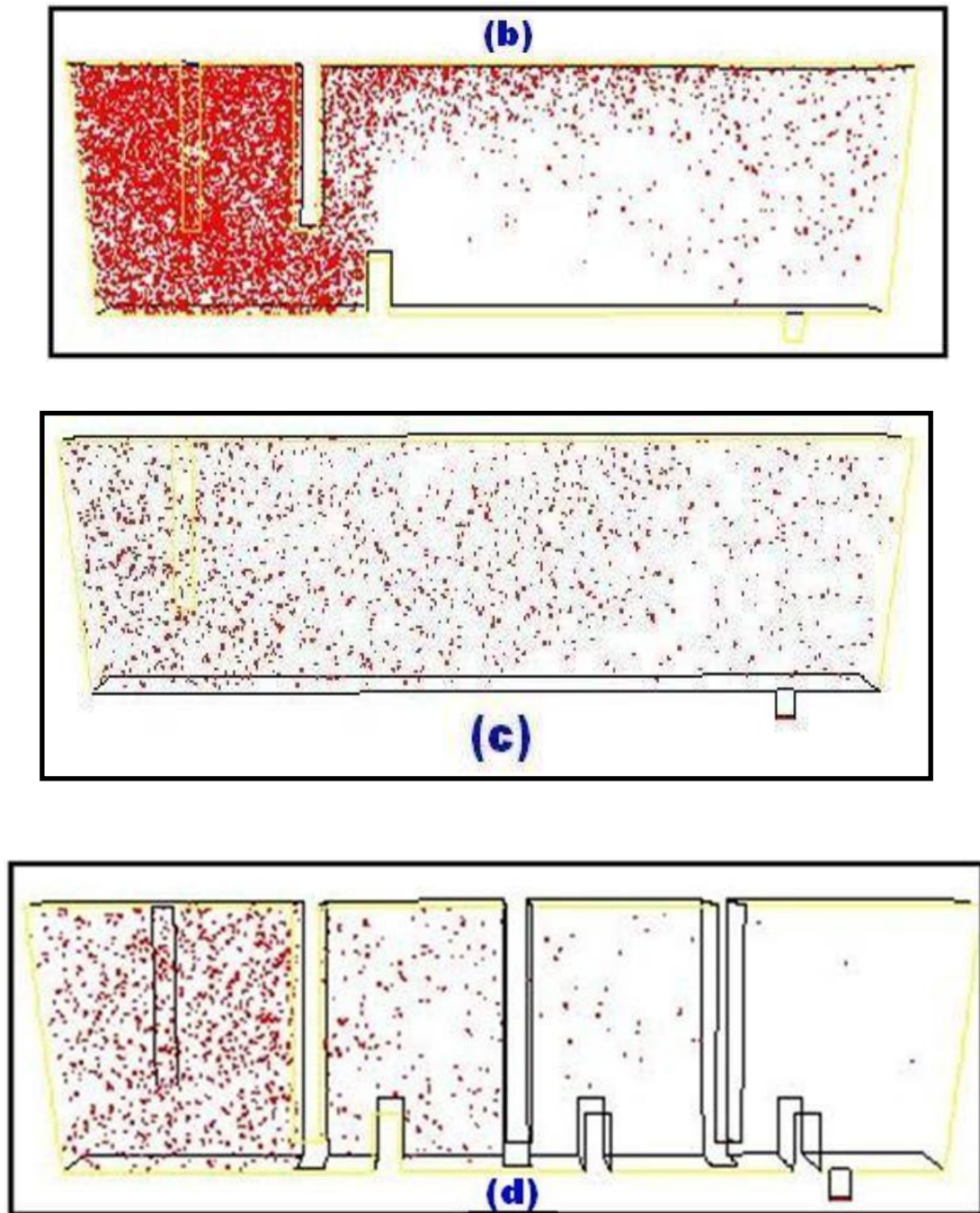

Figure 4 Flow of inclusions particle of diameter $50 \mu\text{m}$ in (a) Normal tundish, (b) Tundish equipped with weir and dam, (c) Tundish with bottom argon purging, (d) Novel Multi Reactor Tundish with Argon Purging [13].

Many single strand tundishes has been developed till now for removing the inclusions and developing clean steel. Centrifugal Tundish developed by JFE Steel Corporation Japan and H Shaped Tundish developed in Nagoya Japan in the year 2000 are shown schematically in Figure 5 (a) and (b) respectively [28].

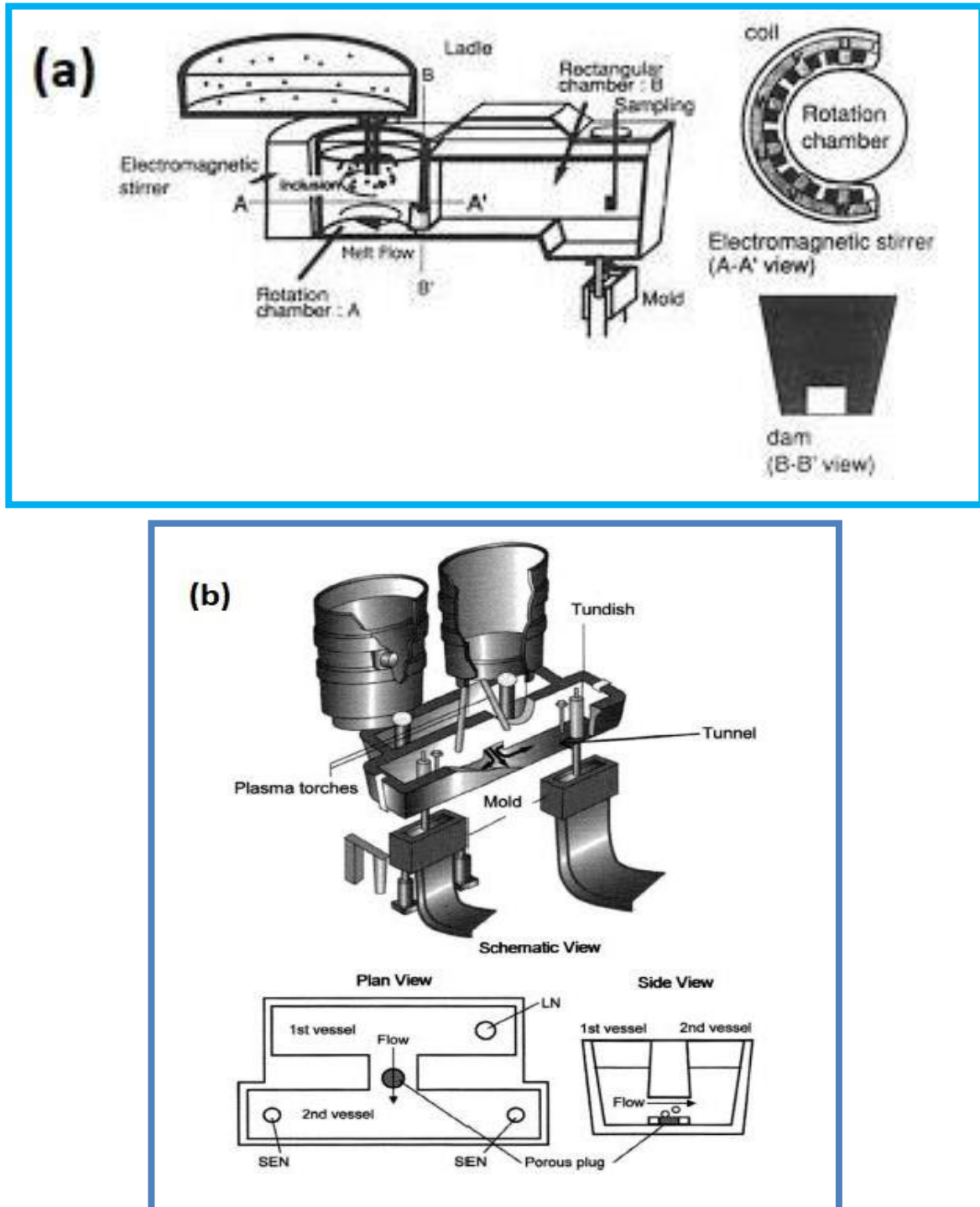

Figure 5 (a) Centrifugal Flow Tundish (b) H- Shaped Tundish [28]

Future Work

From the above study it is clear that flow control products have a great role for producing quality steel and improve yield in tundish. So in present investigation A Dam – Special Weir with Argon Purging Pad – Dam arrangement has been proposed which will be incorporate within single strand tundish to remove inclusions and improve the yield in single strand slab casting tundish as depicted in [Figure 6 \(a\) and \(b\)](#) and [Figure 7](#) respectively. It is a novel technology which no body have employed early in any tundish system. After process modeling U S Patent can be filed.

Before doing plant trial some laboratory scale investigation is prerequisite. Numerical investigations by ANSYS FLUENT software is required to see the insight. Same time physical modeling study by using water modeling experimental set up is required to judge validity of the numerical results with experimental investigations. After plan trial chemical analysis of the transition slab is required by spectrometer. Scanning electron microscope study of number inclusions particles is essential to judge the improvement of quality of steel.

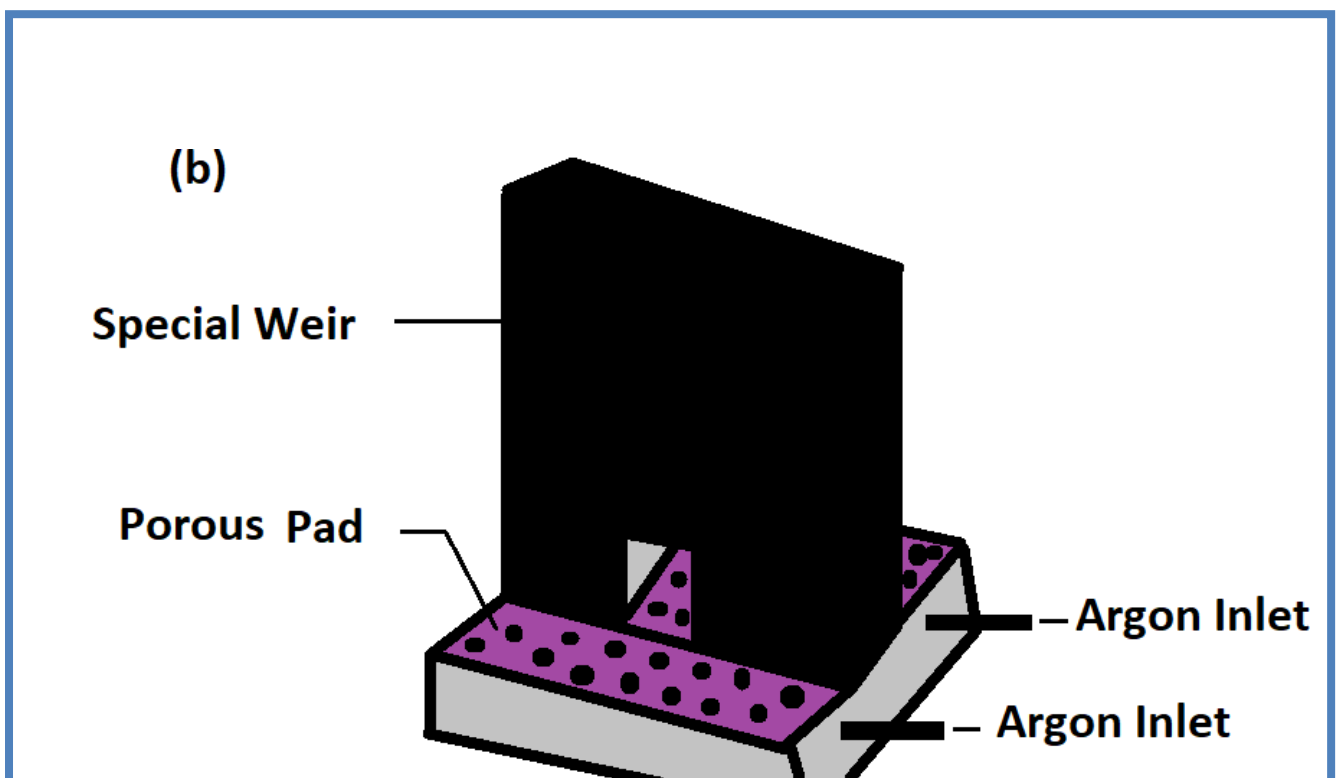
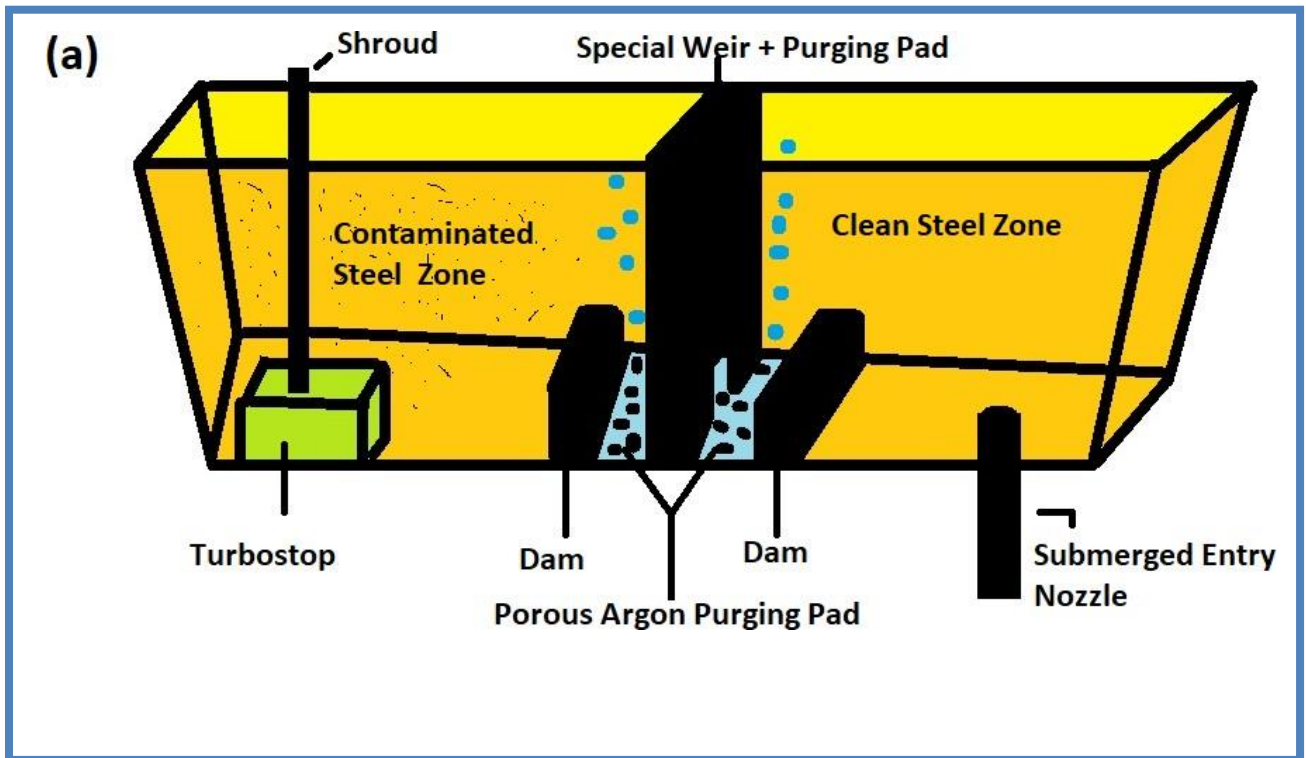

Figure 6 (a) Schematic of Novel Filter Tundish (b) Schematic of the Special weir with Argon Purging Pad.

Novel Design of Tundish

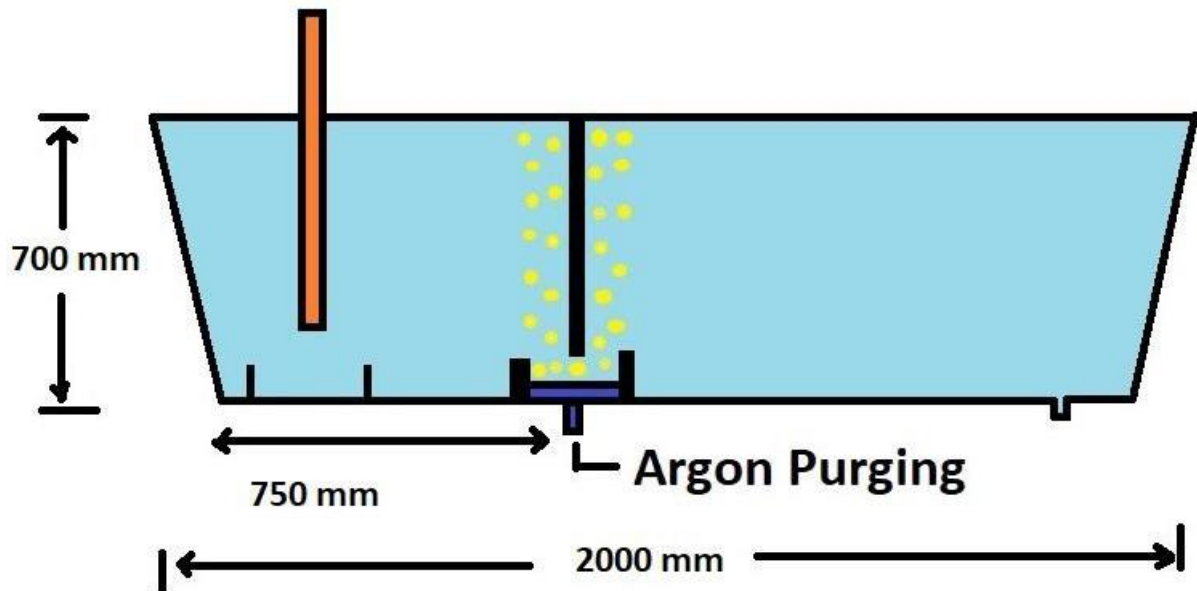

Figure 7. Model Novel Tundish Geometry with Dimensions

References

1. D. Mazumdar: Tundish Metallurgy: Towards Increased Productivity and Clean Steel, *Trans Indian Inst Met* (October–December 2013) 66(5–6):597–610.
2. Yogeshwar Sahai: Tundish Technology for Casting Clean Steel: A Review, *Metallurgical and Materials Transactions B*, Volume 47B, August 2016, 2095-2106.
3. Huiqing Sarah Chen and Robert D. Pehlke: Mathematical Modeling of Tundish Operation and Flow Control to Reduce Transition Slabs, *Metallurgical and Materials Transactions B*, Volume 27B, October 1996, 745-756.
4. Mehdi Alizadeh, Hossein Edris and Ahmad Reza Pishevar: Behavior of Mixed Grade during the Grade Transition for Different Conditions in the Slab Continuous Casting, *ISIJ International*, Vol. 48 (2008), No. 1, pp. 28–37.
5. Marcela B. Goldschmit, Sergio P. Ferro, Guillermo F. Walter, Virginia G. Aranda, and Jorge A. Tena Morelos: Numerical Model for the Minimization of Intermixed Round Bars in a Four Line Continuous Caster, *Metallurgical and Materials Transactions B*, Volume 32B, June 2001, 537-546.
6. Myung Jong Cho and In Cheol Kim: Simple Tundish Mixing Model of Continuous Casting during a Grade Transition, *ISIJ International*, Vol. 46 (2006), No. 10, pp. 1416–1420.
7. Myung Jong Cho and Sang Joon Kim: A Practical Model for Predicting Intermixed Zone During Grade Transition, *ISIJ International*, Vol. 50 (2010), No. 8, pp. 1175–1179.
8. Alexander Braun, Marek Warzecha, and Herbert Pfeifer: Numerical and Physical Modeling of Steel Flow in a Two-Strand Tundish for Different Casting Conditions, *Metallurgical and Materials Transactions B*, Volume 41B, June 2010, 549-559.
9. Chao Chen, Lage Tord Ingemar Jonsson, Anders Tilliander, Guoguang Cheng, and Par Goran Jonsson: A Mathematical Modeling Study of Tracer Mixing in a Continuous Casting Tundish, *Metallurgical and Materials Transactions B*, Volume 46B, February 2015, 169-190.
10. Tomasz Merder and Marek Warzecha: Optimization of a Six-Strand Continuous Casting Tundish: Industrial Measurements and Numerical Investigation of the Tundish Modifications, *Metallurgical and Materials Transactions B*, Volume 43B, August 2012, 856-868.
11. Robert D. Pehlke: Computer Simulation of Solidification Processes—The Evolution of a Technology, *Metallurgical and Materials Transactions B*, Volume 33B, August 2002, 519-541.
12. Roderick I.L. Guthrie: Fluid Flows in Metallurgy—Friend or Foe?, *Metallurgical and Materials Transactions B*, Volume 35B, June 2004, 417-437.
13. Debasish Chatterjee: A Novel Tundish for Single Strand Slab Casting, *J. Inst. Eng. India Ser. D* (July–December 2016) 97(2):105–112.
14. Somnath Basu, Shiv Kumar Choudhary and Narendra U. Girase: Nozzle Clogging Behaviour of Ti-bearing Al-killed Ultra Low Carbon Steel, *ISIJ International*, Vol. 44 (2004), No. 10, pp. 1653–1660.
15. Lifeng Zhang and Brian G. Thomas: State of the Art in the Control of Inclusions during Steel Ingot Casting, *Metallurgical and Materials Transactions B*, Volume 37B, October 2006, 733-761.
16. Lifeng Zhang, Brian G. Thomas: Inclusions in Continuous Casting of Steel, XXIV National Steelmaking Symposium, Morelia, Mich, Mexico, 26-28, Nov. 2003, pp. 138-183.
17. S. Joo, J.W. Han, and R.I.L. Guthrie: Inclusion Behavior and Heat-Transfer Phenomena in Steelmaking Tundish Operations" Part II. Mathematical Model for Liquid Steel in Tundishes, *Metallurgical Transactions B*, Volume 24B, October 1993, 767-777.
18. Chao Chen, Peiyuan Ni, Lage Tord Ingemar Jonsson, Anders Tilliander, Guoguang Cheng, and Pargoran Jonsson: A Model Study of Inclusions Deposition, Macroscopic Transport, and Dynamic Removal at Steel–Slag Interface for Different Tundish Designs, *Metallurgical and Materials Transactions B*, Volume 47B, June 2016, 1916-1932.
19. Haitao Ling, Lifeng Zhang, and Hong Li: Mathematical Modeling on the Growth and Removal of

- Non-metallic Inclusions in the Molten Steel in a Two-Strand Continuous Casting Tundish, *Metallurgical and Materials Transactions B*, Volume 47B, October 2016, 2991-3012.
20. Yun Wang, Yunbo Zhong, Baojun Wang, Zuosheng Lei, Weili Ren and Zhongming Ren: Numerical and Experimental Analysis of Flow Phenomenon in Centrifugal Flow Tundish, *ISIJ International*, Vol. 49 (2009), No. 10, pp. 1542–1550.
 21. Qinfu Hou, Qiang Yue, Huanyang Wang, Zongshu Zou and Aibing Yu: Modelling of Inclusion Motion and Flow Patterns in Swirling Flow Tundishes with Symmetrical and Asymmetrical Structures, *ISIJ International*, Vol. 48 (2008), No. 6, pp. 787–792.
 22. Y. Miki, S. Ogura, T. Fujii: Separations of inclusions from molten steel in a tundish by use of a rotating electromagnetic field, *Kawasaki steel technical report no. 35*, November 1996, 67-73.
 23. Yuji Miki, Hidenari Kitaoka, Toshikazu Sakuraya and Tetsuya Fujii: Mechanism with a for Rotating Separating Inclusions from Electro-magnetic Field, *ISIJ International*, Vol. 32 (1 992), No. 1, pp. 142-1 49.
 24. Henrik Solhed, Lage Jonsson, and Par Jonsson: A Theoretical and Experimental Study of Continuous-Casting Tundishes Focusing on Slag-Steel Interaction, *Metallurgical and Materials Transactions B*, Volume 33B, April 2002, 173-185.
 25. S. Joo, J.W. Han, and R.I.L. Guthrie: Inclusion Behavior and Heat-Transfer Phenomena in Steelmaking Tundish Operations" Part II1. Applications--Computational Approach to Tundish Design, *Metallurgical Transactions B*, Volume 24B, October 1993, 779-788.
 26. D. Satish Kumar, T. Rajendra, Reddi Prasad, A. Sarkar and Madhu Ranjan: Forced flotation of inclusions in tundish, *Ironmaking and Steelmaking*, 2009, Vol 36, No 6, 470-475.
 27. Book: - Y. Sahai, T. Emi: *Tundish technology for clean steel production*, world scientific publisher, 2008, 1-313.
 28. T. Emi, *Steelmaking Technology for the Last 100 Years: Toward Highly Efficient Mass Production Systems for High Quality Steels*, *ISIJ International*, Vol. 55 (2015), No. 1, pp. 36–66.

