

Modeling and Optimization of Simultaneous Removal of Ions (H_2PO_4^- , NO_3^- and Cd^{2+}) by Adsorption on Clay in Aqueous Solution by Using Response Surface Methodology

ABSTRACT

This paper deals with the modeling and optimization of the simultaneous elimination of dihydrogen phosphate nitrate and cadmium ions in an aqueous solution using adsorption on a smectite clay. Pollutant concentration and retention time are the two parameters studied. The experimental domains investigated are respectively from 20 to 100 mg.L^{-1} and from 8 to 16 hours. The tests were conducted with 3g of clay in a 25 mL mixture solution at pH 5. This study has been carried out with Response Surface Methodology (RSM), using NEMROD software. A central composite Design (CCD) was used first to establish a mathematical model that governs the process. The use of Derringer's overall function of desirability permitted to establish optimal conditions of adsorption. Thus, maximum abatement rates both for each ion have been obtained when the pollutant concentration was 43 mg.L^{-1} with an adsorption duration of 15 hours. The results of the purification rates were 30.6%, 68.1%, and 69.07%, respectively for nitrate, dihydrogen phosphate, and cadmium ions. It is noticeable that clay can be used as an adsorbent for wastewater depollution from many pollutants at a time.

Keywords: Clay, experimental design, adsorption, Response Surface Methodology

1. INTRODUCTION

The problem of water availability according to UNESCO lies in the treatment of wastewater given that underground resources are limited [1, 2]. Collection and wastewater treatment facilities are sometimes insufficient or fail [3]. This lack of wastewater treatment results in environmental damage with the phenomenon of eutrophication [4] and endemic diseases related to water such as diarrhea, cholera, typhoid, meningitis, hepatitis A and E [2].

Thus, the search for an alternative that can be suggested to users such as decision-makers, populations, industries, and other sectors as far as wastewater treatment is concerned has become a challenge for the world, especially for researchers. This alternative needs to be easy to implement and less expensive. For this reason, clays are mostly used because of their abundance, adsorbent properties, and exchange capacities [5, 6]. Discharge standards, phosphorus, and nitrate consumption are respectively set at 15 and 50 mg.L^{-1} in Côte d'Ivoire [7]. The discharge norm is more restrictive in Europe as far as phosphorus is concerned; it is set at 2 mg.L^{-1} in accordance with directive n° 98/15/CE of February 27, 1998, by the European Commission. As for cadmium ion (Cd^{2+}), one of the elements called trace element or pejoratively called heavy metals [8], has no useful function in the metabolism of flora, fauna and the human body.

It is highly toxic even when the dosage is low, namely from 0.2 mg.L^{-1} [9,10]. It can replace calcium in bone tissue or zinc in vital organs and create dysfunction [11].

Pollution sources of groundwater, surface water and soil water originate from the effects of atmospheric pollution, industrial wastewater as well as agricultural practices such as the use of fertilizers made with phosphorus containing cadmium and sludge spreading [12]. It is the presence of cadmium ions in inorganic phosphate fertilizers that justifies the attempt of their simultaneous elimination.

Chouchane et al. (2015)[13], Aden (2020)[14] as well as many other researchers use the unitary method referred to as "one factor at a time". This method consists in making each factor vary, one after the other when modifying all the possible values according to Kammoun et al.[15] and Tinsson [16].

The methodology is long, tiresome and has a disadvantage so that it leads to many optimal conditions among which each of them is specific to a given ion. Thus, working on one of these optimal conditions for one of the ions could hamper the elimination of the others.

In such cases of simultaneous optimization of many responses, Derringer and Suich [17] suggested the use of Response Surface Methodology (RSM) and search for a compromise that enables to satisfy all the responses at a time through the function of desirability.

For example, Chakchouk et al.[18] who studied the formulation of mixed cement by adding calcined clay used that methodology.

The particularity of this study is to use the Response Surface Methodology for wastewater treatment and purification and for simultaneous NO_3^- , H_2PO_4^- , Cd^{2+} ions elimination by Adsorption on Clay. The different parameters being the concentration of pollutants and the retention time. The optimal conditions of concentration and the retention time at which the abatement rate is the highest at a time for each ion are determined. Therefore, a Central Composite Design (CCD) is used as experimental design to achieve the modelling of the process and the function of global desirability for optimization.

Experiment Design aims to offer few experiments while simultaneously varying all the factors to obtain as much information as possible[16,19]

The interest of this study lies in it is first time simultaneous adsorption of these three ions on a clay has been addressed. The study also shows its originality through the methodology used to carry it out.

2. MATERIAL AND METHODS

2.1 Sample of Clay

The clay used was collected in Katiola, a town located in the North of Côte d'Ivoire, which is in the Savannah. The geographical coordinates of the sites are $8^{\circ}08.945'N$ and $5^{\circ}05.959'W$. The sample was taken from a depth comprised between 2 and 2.5m. The clay was used under its activated form from 2 μm fraction; this fraction was obtained in accordance with the protocol of Thiry et al.[20] from 50 μm fraction. The protocol of activation has been described in a previous study[6]. The characteristics of this activated clay composed predominantly by smectite and kaolinite, are presented in Table 1.

Table 1. Characteristics of the Activated Clay Used for the Study

Chemical Composition								
SiO_2	Al_2O_3	Fe_2O_3	K_2O	MgO	CaO	Na_2O	MnO	TiO_2
46.29	21.15	12.02	0.03	3.92	0.1	2.8	0.00	0.15
Mineralogical composition (%)								
	Quartz	Smectite	Kaolinite	Goethite				
	4.7	54.8	39.6	0.9				
BET Specific Surface (m^2/g)								
61.33								
Cation Exchange Capacity CEC (méq/100g)								
43.4								

2.2 Preparation of Synthetic Solution

Orthophosphate solutions are prepared in accordance with the French norm NF T 90-023 [21], from potassium dihydrogen-phosphate (KH_2PO_4) having a purity of 99% (Merck). Those of nitrate ions are obtained from potassium nitrate (KNO_3) having a purity of 99% (Merck) in accordance with the French norm NF T 90 045[21]. Cadmium solutions are prepared in accordance with the French norm NF T 90-

112 [21](AFNOR, 1994), from hydrated cadmium salt ($3\text{CdSO}_4 \cdot 8\text{H}_2\text{O}$) having a purity of 98% (Merck). The concentration of these solutions is those of the chemical element (P, N or Cd), noted X in salt, noted A.

The mass of product A to withdraw is calculated thanks to the relation Equation 1 (Eq 1):

$$m_A = \frac{M_A C_0 V}{M_X} \times \frac{100}{p} \quad (\text{Eq 1})$$

Table 2 provides information about molar mass of X element to consider.

Table 2. Data for the calculation of commercial product mass to withdraw for the preparation of a V volume of synthetic solution of mass concentration C_0

X Element	A Salt	Molar Mass of A (g/mol)	Molar Mass of X in A (g/mol)	Purity p in A (%)
P	KH_2PO_4	136.12	31	99
N	KNO_3	101.1	14	99
Cd	$3\text{CdSO}_4 \cdot 8\text{H}_2\text{O}$	769.51	$3 \times 112,411 = 337,833$	98

Salts are weighed and dissolved in bidistilled water. The desired pH, i.e. 5, is adjusted thanks to 15% sulfuric acid ($\rho = 1.84 \text{ g/mL}$) and a sodium hydroxide solution (120 g.L^{-1}) and monitored by a numerical pH-meter, type EUTECH INSTRUMENTS version ION 2700. KH_2PO_4 and KNO_3 solutions have been measured for dosage before and after adsorption by spectrophotometry respectively at 880 nm and 415 nm thanks to a JASCO V-530 spectrophotometry coupled to a computer having SPECTRA MANAGER software. It enables to connect the A absorbance to the C content in pollutant. The dosage in cadmium ion is done through Atomic Adsorption spectroscopy in flame using the AA Spectra device, which is equipped with an autosampler.

2.3 Adsorption Test

Adsorption parameters studied in this research are ion concentration in mixture and retention time. The tests are done with 3g of activated clay put in a flask containing a 25 ml at pH 5 mixed solution. This pH was set by taking into account previous results [21, 22, 23], according to which the adsorption was efficient for each ion at this pH value.

in indeed, adsorbate's pH is an important parameter in the study of adsorption [25]. pH influences clay's surface charge as well as that of the adsorbent. Clays are also known to have a negative surface charge in solution. Thus, when pH changes, surface charge also changes and adsorption of charged species is affected. In an alkaline solution for example, the concentration of Cd^{2+} ions decreases due to the formation of the $\text{Cd}(\text{OH})_2$ precipitate [26]; which contributes to disfavoring the adsorption of this ion. Hamdi and Srasra [25] also observed that the adsorption of phosphate ions by clay increases weakly with increasing pH up to a maximum around pH 5 and then decreases as the solution becomes more basic due to competition with OH^- . At a lower pH, the clay becomes protonated and causes repulsion of cadmium ions. In the case of phosphate ions, it is their molecular form H_3PO_4 which becomes predominant and their adsorption decreases. For nitrate ions, adsorption decreases in a basic solution according to [27] due to the negative charge of clays which causes anions electrostatic repulsion.

The study was carried out at 30°C of temperature, in a cooling thermostat (JULABO, SWI) that oscillates horizontally at a speed of 100 oscillations/min to ensure agitation.

2.4 Response Surface and Desirability Function Methodologies

The coded variables of the factors studied are X_1 for concentration in pollutant and X_2 for retention time, representing the duration of the contact between the adsorbent, which is clay and the pollutant. What matters here is to find out the concentration and the retention time that led to the maximum abatement rate at a time, for each ion in the mixture. The search for conditions that optimize the elimination of the three ions at a time requires the use of RSM and the use of the global desirability function [17]. This

process of optimization is operated with NEMROD-W 9901 french version software [28]. The expected response will be abatement rate Y in pollutant, which is calculated according to Equation 2 (Eq 2):

$$Y = \frac{(C_0 - C_{res})}{C_0} * 100 \quad (\text{Eq. 2})$$

In this relation, C_0 and C_{res} are expressed in mg.L^{-1} , respectively representing initial and residual concentrations in ion in the mixture.

Firstly, a CCD, will permit to find the 2nd degree mathematical model followed by each response in the mixture, Equation 3 (Eq 3) :

$$Y_M = a_0 + \sum a_i X_i + \sum \sum a_{ij} X_i X_j + \sum a_{ii} X_i^2 \quad (\text{Eq 3})$$

The validity of the models will be motivated by the interpretation of statistics data; the determination of R^2 coefficient and R^2 adjusted, R_A^2 , as well as the results of the analysis table of variance released by the software used for the study. In this relation, (a_0) represents the minimum effect, (a_i) are the main coefficient, (a_{ij}) are the coefficients of second order interaction and (a_{ii}) , the coefficients of squares. The CCD, which is a composite design, contains three types of experimental designs [16]. With $k = 2$ factors of study, 2^k tests in Full Factorial Design (FD), with 2 levels (-1 and +1) in coded value; $2 \times k$ tests in star with 2 other levels in $(-\alpha \text{ et } +\alpha)$; with $\alpha = 2^{k/4}$. Some tests, i.e 5, was conducted in the center of the experimental domain to ensure to the final matrix a pseudo-orthogonality and an isovariance of the measures on all the domain [6,16,25]. **Figure 1** represents the distribution of experimental points of a central composite design for two factors [29].

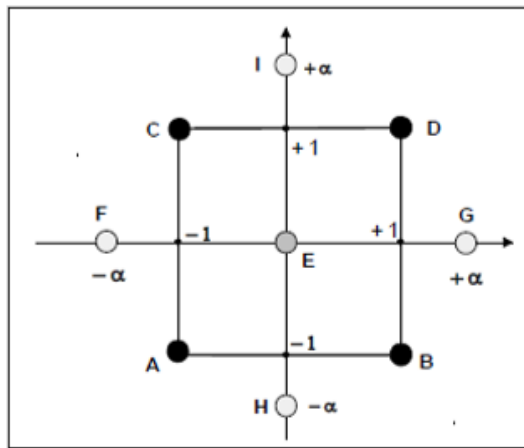

Figure 1: Graphic interpretation of experimental points of a central composite design with two factors [30].

A, B, C, D are the 2^2 points related of the FD while F, G, H and I are the axial points indicating the star tests (2×2). The latter points are in a distance $\pm \alpha$ of the center with $\alpha = 2^{2/4} = 2^{1/2}$. Point E represents the tests in the center, which are to be replicated in accordance with Draper's recommendations [31]. Thus, this experimental domain is defined with 5 levels (Table 3) and an experimental design (Table 4) predicting 13 tests to be conducted.

Table 3. Factors and experimental domain for the central composite design during the optimization of the competitive adsorption of pollutants.

Variables	Levels				
	$-\alpha = -\sqrt{2}$	-1	0	+1	$+\alpha = +\sqrt{2}$
X1 (concentration mg/L)	20	31,7	60	88,3	100
X2 (retention time h)	8	9	12	15	16

Table 4. Matrix and experimental plan of CCD (q = 2)

n° exp	Factors			
	Coded variables		Real Variables	
	X ₁	X ₂	U ₁ (Concentration) (mg/L)	U ₂ (retention time) (h)
1	-1	-1	32	9
2	+1	-1	88	9
3	-1	+1	32	15
4	+1	+1	88	15
5	-1.414	0	20	12
6	+1.414	0	100	12
7	0	-1.414	60	8
8	0	+1.414	60	16
9	0	0	60	12
10	0	0	60	12
11	0	0	60	12
12	0	0	60	12
13	0	0	60	12

The optimal conditions of elimination specific for each ion are determined by analysing the response surfaces and iso-response curves of each of them.

In the case any common condition that maximizes the abatement rate is found, therefore a compromise is expected by using the partial desirability function « d_i », is calculated with to Equation 4 (Eq 4) or given by the NEMROD-W software used for the study:

$$d_i = \left(\frac{Y_i - Y_{i\min}}{Y_{i\max} - Y_{i\min}} \right)^r, \text{ pour } Y_{i\min} \leq Y_i \leq Y_{i\max} \text{ (Éq 4).}$$

In this equation, $Y_{i\min}$ et $Y_{i\max}$ respectively represents the minimum value and the maximum value of Y_i response. The exponent r , called weight, which is arbitrarily chosen by the experimenter is taken as 1 in this study. The desirability function varies between 0 and 1. Thus, a criterion of optimization or compromise will be satisfying when the desirability function is closer to 1. However, the criterion is not acceptable, but rejected, when this desirability function gets closer to 0. The partial desirability functions that permit to have access to the targets that indicate the values of each response should get closer to during the search for compromise. Then, a unique function of global desirability (D) is then calculated using Equation 5 (Eq 5) :

$$D = (d_1 \times d_2 \times d_3)^{1/3} \quad \text{(Eq 5)}$$

The values of « d_i » are the ones that maximize D which allow to determine the expected optimal conditions through the software in used.

3. RESULTS AND DISCUSSION

3.1 Results of Tests and Validation of Models

Table 5 indicates the competitive elimination rates for H_2PO_4^- , NO_3^- and Cd^{2+} ions regarding the experimental tests.

Table 5. Experimental design and results of abatement rates for competitive elimination

N° exp	Factors		Abatement rate (%)		
	Concentration (mg.L ⁻¹)	Adsorption duration (h)	Y _P (%)	Y _N (%)	Y _{Cd} (%)
1	32	9	68.50	28.00	69.50
2	88	9	60.00	23.20	61.00
3	32	15	71.50	32.0	72.80
4	88	15	63.76	27.08	64.50
5	20	12	72.80	31.30	74.50
6	100	12	60.82	23.02	61.80
7	60	8	60.00	21.33	61.13
8	60	16	64.30	30.66	65.80
9	60	12	61.33	26.66	62.00
10	60	12	62.00	26.00	63.60
11	60	12	60.66	27.26	61.10
12	60	12	61.66	26.26	62.55
13	60	12	60.20	27.53	60.80

The three models of surface are stated by Equations 6, 7 and 8 (Eq 6), (Eq 7) et (Eq 8) in which X_1 represents the concentration in adsorbate and X_2 , the retention time.

$$Y_P = 61,170 - 4,148X_1 + 1,605 X_2 + 3,185X_1^2 + 0,855X_2^2 + 0,190X_1X_2 \quad (\text{Eq 7})$$

$$Y_N = 26,742 - 2,679X_1 + 2,643X_2 + 0,457X_1^2 - 0,125X_2^2 - 0,030X_1X_2 \quad (\text{Eq 6})$$

$$Y_{Cd} = 62,010 - 4,345X_1 + 1,676X_2 + 3,356X_1^2 + 0,013X_2^2 + 0,050X_1X_2 \quad (\text{Eq 8})$$

Also, the coefficients R^2 and R_A^2 related to the variance analysis are presented in Table 6 and Table 7.

Table 6. R^2 and R_A^2 values for competitive elimination

	Y _P	Y _N	Y _{Cd}
R^2	0,972	0,937	0,970
R_A^2	0,953	0,892	0,958

Table 7. Analysis of variance of Y_P, Y_N and Y_{Cd} responses for the competitive elimination.

Responses	Variation source	Sum of squares	Degree of liberty	Average of squares	Ratio	Significatively
Y _P	Regression	230.32	5	46.06	49.32	***
	Residue	6.53	7	0.93		
	Validity	4.38	3	1.46	2.71	**
	Pure error	2.15	4	0.53		
	Total	236.86	12			
Y _N	Regression	114.62	5	22.92	20.90	***
	Residue	7.67	7	1.09		
	Validity	5.99	3	1.99	4.76	**
	Pure error	1.68	4	0.42		
	Total	122.29	12			

Y _{Cd}	Regression	254.18	5	50.83	45.07	***
	Residue	7.89	7	1.12		
	Validity	2.78	3	0.92	0.72	**
	Pure error	5.11	4	1.27		
	Total	262.07	12			

These results show how the total sums of squares are distributed between the different sources of variation. As we can notice, the sums of squares due to the residues are all inferior to one third due to regression[16]. The determination of coefficients are done in accordance with the required limits with $R^2 > 0.80$ et $R_A^2 > 0.77$ [32, 33]

These significant statistical data permit to conclude that there is an adequacy to the degree 2 model for the follow-up of this competitive adsorption[18,16, 6].

3.2 Exploitation of Models

Relations that exist between each response and variables are illustrated by iso-response curves or by corresponding response surfaces (Figure 2, Figure 3 and Figure 4). Figure 2, Figure 3 and Figure 4 are related to dihydrogenphosphate ions (Y_P), to nitrate ions (Y_N) to cadmium ions (Y_{Cd}) respectively. Each of these diagrams allows to understand the effect of the two factors of the study on each response in the experimental domain.

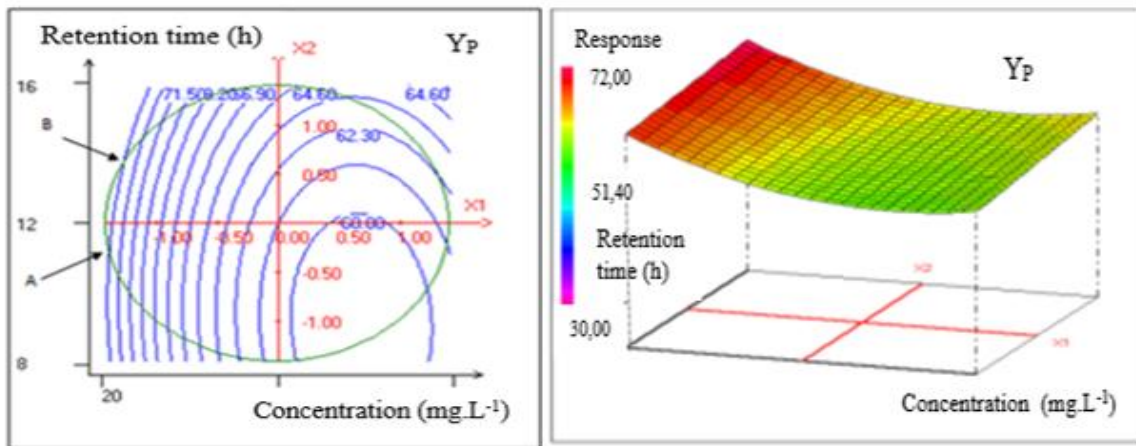

Figure 2: Iso-response curve and surface response of abatement rate in dihydrogen and phosphate ion in the mixture.

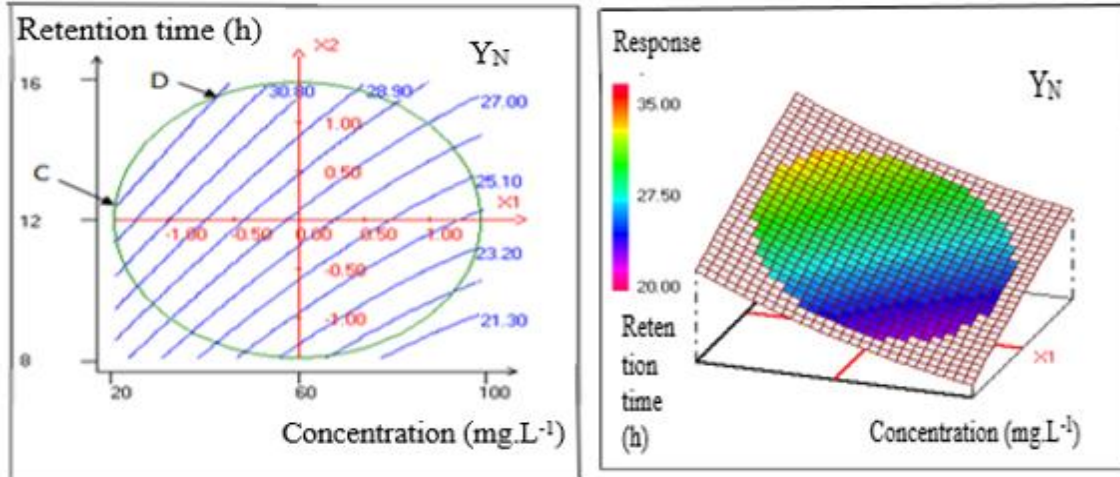

Figure 3: Iso-response curve and surface response of the abatement rate in nitrate ion in the mixture.

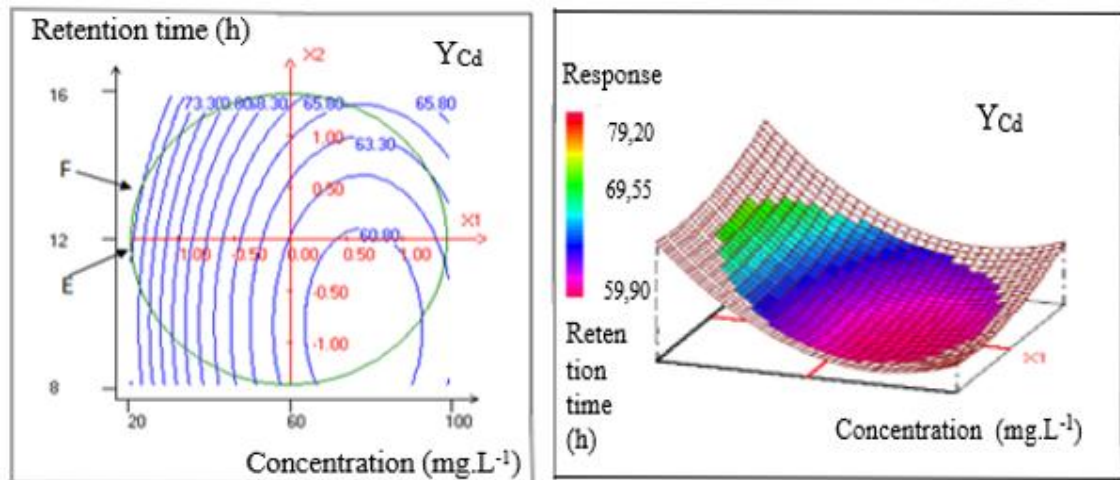

Figure 4: Iso-response curve and response surface of the abatement rate in cadmium ion in the mixture.

These curves and response surfaces have some similarities. Indeed, all the curves of iso-response show that for a given ion and for the same abatement rate, the retention time depends on the concentration in ion. When the initial concentration is higher, the retention time is also longer. Moreover, for a given retention time, the performance decreases since the concentration in ions increases. Likewise, for the same ion concentration, the performance is better for a longer retention time. Finally, for two different abatement rates and for the same adsorption duration, the performance decreases when the concentration in ion increases. A similar result has been reported by Chouchane *et al.*[13]. The latter ones studied the elimination of nickel and lead ions by adsorption on crushed kaolin sifted at 200 μm . They also noticed that ions adsorption was more important for solutions having low initial concentration. This result may be explained by the fact that for a given mass of clay, the adsorption sites available have been defined in advance. Thus, when these sites are occupied after adsorption, other additional quantities of adsorbate due to the increase in their concentration cannot be adsorbed anymore. Therefore, a decrease of the abatement rate is observed. Concerning the optimal conditions, iso-response curves show that the maximum abatement rates for each ion are not obtained under the same experimental conditions. For example, for dihydrogenphosphate ions in Figure 2, the highest abatement rate, which is 72.80%, likely to be obtained after a duration of 11.5 h for a 25 mg.L^{-1} concentration is in point A or a duration of 13.5h for a 30 mg/L concentration in point B. For nitrate ions, as depicted in Figure 3, the 32% maximum rate is obtained after 12.5 h of retention time for a 25 mg.L^{-1} concentration in nitrate ion (point C) or after 15.5 h for 50 mg.L^{-1} (point D). For cadmium ions, in Figure 4, the maximum rate, which is around

74% is obtained after a duration of 11h for a 22 mg.L⁻¹ concentration noticeable in point E or a maximum duration of 13.5h for nearly 25 mg/L concentration (point F). These results are all summarized in Table 8.

Table 8. Summary of the conditions for obtaining maximum adsorption rates for each ion in the mixture.

	Ions					
	H ₂ PO ₄ ⁻		NO ₃ ⁻		Cd ²⁺	
Maximum abatement rate (%)	72.8		32		74	
Minimum duration (h)	A	11.5	C	12.5	E	11
Minimum concentration (mg.L ⁻¹)		25		25		22
Maximum duration (h)	B	13.5	D	15.5	F	13.5
Minimum concentration (mg.L ⁻¹)		30		50		25

These maximum abatement rates are not obtained in the same experimental conditions for all the ions at a time. It means that a compromise is to be searched between different criteria. The optimization of the three responses focuses on the functions of partial desirability « d_i » of each of the responses. These desirabilities are chosen as illustrated in Figure 5. The target G in Figure 5a), 5b) and 5c) represents the abatement rate to reach. It may also permit each function « d_i » to maximize the global desirability D.

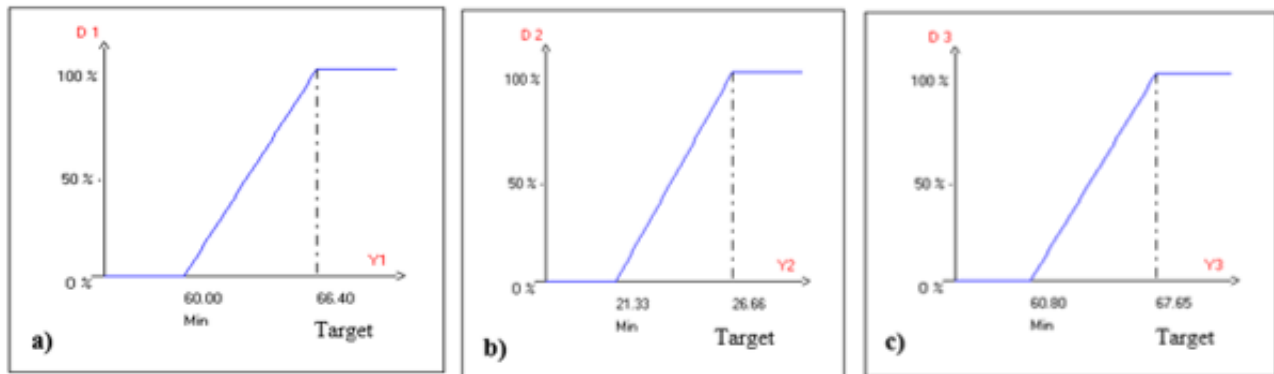

Figure 5: Function of individual desirability of responses Y_i: a), abatement rate in phosphate (Y₁); b), abatement rate in nitrate (Y₂); c), abatement rate in cadmium (Y₃)

The curve of global desirability (D) with two dimensions, plotted in Figure 6, shows that a compromise with desirability D equal to 1 can be found.

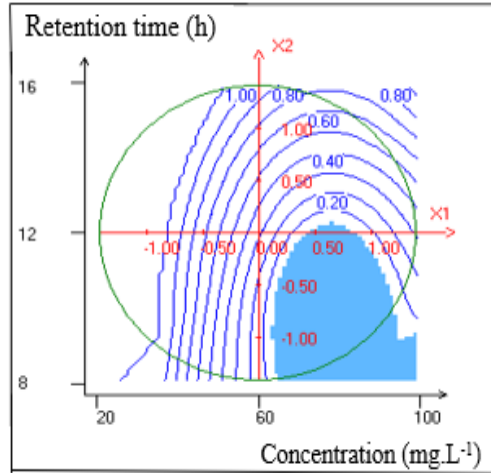

Figure 6:Global desirability iso-response curve

At this stage, for the search for compromise, the software suggests many solutions. The choice made in this study aimed at searching for the greatest concentration that the 3g of clay used could eliminate with a great abatement rate for each of the ions at a time. The selected compromise after calculation corresponds to an experiment having a duration of 15 h ($X_2 = 1,043619$) for a concentration in ions of 43 mg/L ($X_1 = - 0,604592$). The abatement rates found by the software in these optimal conditions of adsorption are 67.33 % for phosphate ions; 31.16% for nitrate ions and 68.68% for cadmium ions (Table 9).

Table 9. Summary of conditions that enable to get maximum adsorption rates during the competitive elimination obtained for 15 h and 43 mg.L⁻¹

Responses	Corresponding ions	Value	d _i %	Weight	d _i min %	d _i max %
Y _P	dihydrogenphosphate	67.33	100.00	1	99.41	100.00
Y _N	Nitrate	31.16	100.00	1	100.00	100.00
Y _{Cd}	Cadmium	68.68	100.00	1	99.59	100.00
	Desirability D		100.00	--	99.67	100.00

To validate the theoretical results, some additional experiments essays have been conducted using the optimal conditions. The experimental responses obtained, $Y_P = (68.1 \pm 1.1)\%$, $Y_N = (30.6 \pm 0.9)\%$ et $Y_{Cd} = (69.1 \pm 0.9)\%$, match very well with the predictions.

4. CONCLUSION

This study dealt with the elimination of ions in mixture in an aqueous solution, through adsorption on a clay. Particularly, the objective was to determine in a concentration range from 20 to 100 mg.L⁻¹ in pollutants, for which retention time and concentration, the adsorption rate would be the highest for each ion at a time. The retention time studied varies from 8 to 16 h. The Response Surface Methodology and the global desirability function of DERRINGER were used for this purpose. Interactions between the two factors have been explained through the iso-response curves. It was found that for two different

abatement rates and for the same retention time, the adsorption efficiency decreases as the concentration in ion increases. Moreover, for the same concentration, when the retention time increases, this efficiency also increases.

The function of desirability enabled to state that the abatement rates are important for each ion for a concentration in pollutants in the mixture of 43 mg.L^{-1} and a retention time of 15 h. The tests conducted according to these optimal conditions allowed to set the residual concentration at 14.0; 2.6 and 13.5 mg.L^{-1} respectively for dihydrogenphosphate, nitrate and cadmium ions. The corresponding abatement rates are respectively $(68.1 \pm 1.1) \%$, $(30.6 \pm 0.9) \%$ and $(69.1 \pm 0.9) \%$.

This study showed the interest of the methodology that has been used. With only 13 tests, the methodology enabled to reach the objective of the study. Mineralogical analyses of clay after adsorption will permit to qualitatively explain the difference between the abatement rates obtained.

REFERENCES

- [1] UN WATER, "Wastewater: an untapped resource," 2017. [Online]. Available: [United Nations World Water Development Report 2017 ; 203 pp.](#)
- [2] UN WATER, "Wastewater—The Untapped Resource; The United Nations World Water Development Report 2017," 2017. [Online]. Available: <http://creativecommons.org/licenses/by-sa/3.0/igo/>.
- [3] J. Nikiema, A. Figoli, N. Weissenbacher, G. Langergraber, B. Marrot, and B. Moulin, "Wastewater treatment practices in Africa - experiences from seven countries," *Sustain. Sanit. Pract.*, vol. 14, pp. 26–34, 2013, [Online]. Available: cgspace.cgiar.org/handle/10568/40210.
- [4] S. Pitois, M. H. Jackson, and B. J. B. Wood, "Sources of the eutrophication problems associated with toxic algae: An overview," *Journal of Environmental Health*, vol. 64, no. 5. pp. 25–32, 2001.
- [5] D. E. Aminy, B. Rusdianto, and M. Mudasar, "Adsorption of Cd(II) ion from the solution using selective adsorbent of dithizone-modified commercial bentonite," *Int. J. Environ. Sci. Technol.*, vol. 19, no. 7, pp. 6399–6410, 2022, doi: 10.1007/s13762-021-03570-1.
- [6] Y. J. Adjoumani, P. J. M. R. Dablé, K. E. Kouassi, S. Gueu, A. S. Assémian, and K. B. Yao, "Modeling and Optimization of Two Clays Acidic Activation for Phosphate Ions Removal in Aqueous Solution by Response Surface Methodology," *J. Water Resour. Prot.*, vol. 11, no. 02, pp. 200–216, 2019, doi: 10.4236/jwarp.2019.112012.
- [7] ORDER, "ORDER N° 01164 of November 04, 2008 Regulating Discharges and Emissions from Installations Classified for the Protection of the Environment," 2008. [Online]. Available: <https://www.envipur.com/docs/reglementation/ARRETE SIIC - REJECTIONS OF EMISSIONS.pdf>.
- [8] D. Baize, "Total levels of trace metal elements in soils (France). References and interpretation strategies. INRA Editions, Paris." 1997.
- [9] D. T. Sun *et al.*, "Selective heavy metal removal from water by a metal-organic framework/polydopamine composite," *ACS Central Science*, 2018.
- [10] Z. Bahnes, "Activation of jujube kernels to obtain activated carbon," Doctoral Thesis, Abdelhamid Ibn Badis Mostaganem University, Algeria, 2018.
- [11] O. Barbier, G. Jacquillet, M. Tauc, M. Cougnon, and P. Poujeol, "Effect of heavy metals on, and handling by, the kidney," *Nephron Physiol*, vol. 99, pp. 105–110, 2005.
- [12] Y. H. A. Yapi, B. K. Dongui, T. A. Y. S. S. Barima, Y. Essis, and P. Athéba, "Evaluation of metal pollution of groundwater and surface water in a gold mining environment in Hiré," *Int. J. Biol. Chem. Sci.*, vol. 8, no. 3, pp. 1281-1289., 2014, doi: 10.4314/ijbcs.v8i3.41.

- [13] T. Chouchane, S. Chouchane, A. Boukari, and A. Mesalhi, "Adsorption of binary mixture « Lead-Nickel » by kaolin," *J. Mater. Environ. Sci.*, no. February, pp. 924–941, 2015.
- [14] M. Aden, "Adsorption of Pb (II) and Ni (II) ions on functionalized silica particles deposited on natural biopolymers for wastewater treatment.," Inorganic chemistry, Université Bourgogne Franche-Comté, 2020.
- [15] R. Kammoun, B. Naili, and S. Bejar, "Application of a statistical design to the optimization of parameters and culture medium for α -amylase production by *Aspergillus oryzae* CBS 819.72 grown on gruel (wheat grinding by-product)," *Bioresour. Technol.*, vol. 99, no. 13, pp. 5602–5609, 2008, doi: 10.1016/j.biortech.2007.10.045.
- [16] Tinsson W, "Experimental designs: constructions and statistical analyzes," *Springer Sci. Bus. Media*, vol. 67, p. 532, 2010, doi: DOI 10.1007/978-3-642-11472-4_1.
- [17] G. Derringer and R. Suich, "Simultaneous Optimization of Several Response Variables," *J. Qual. Technol.*, vol. 12, no. 4, pp. 214–219, 2018, doi: 10.1080/00224065.1980.11980968.
- [18] A. Chakchouk, L. Trifi, B. Samet, and S. Bouaziz, "Formulation of blended cement: Effect of process variables on clay pozzolanic activity," *Constr. Build. Mater.*, vol. 23, no. 3, pp. 1365–1373, 2009, doi: 10.1016/j.conbuildmat.2008.07.015.
- [19] Feinberg M, "Validation of analytical methods: a chemometric approach to quality assurance in the laboratory", Ed MASSON. 1996.
- [20] M. Thiry, N. Carrillo, C. Franke, and N. Martineau, "Technique for preparing clay minerals for analysis by X-ray diffraction and introduction to the interpretation of diagrams. Technical report N° RT131010MTHI," 2013.
- [21] AFNOR, "Water Trials. Determination of phosphates, polyphosphates and total phosphorus (spectrometric method)". In: *Water quality. French Association for Standardization*. In: *Qualité de l'eau*. Association Française de normalisation, Paris, 1994.
- [22] P. J. M. R. Dablé, Y. J. Adjoumani, B. Yao, and G. Ado, "Wastewater dephosphorization using crude clays," *Int. J. Environ. Sci. Technol.*, vol. 5, no. 1, pp. 35–42, 2008, doi: 10.1007/BF03325995.
- [23] M. Bouguerra, "Study of the elimination of nitrate ions in agri-food effluents using a mesoporous organosilicate adsorbent," Doctoral thesis, Université de Laval, Québec, Canada, 2010.
- [24] L. Pan, Z. Wang, Q. Yang, and R. Huang, "Efficient Removal of Lead, Copper and Cadmium Ions from Water by a Porous Calcium Alginate/Graphene Oxide Composite Aerogel," *Nanomater. vol 8*, 957- 972; doi:10.3390/nano8110957, vol. 8, pp. 957–972, 2018, doi: 10.3390/nano8110957.
- [25] N. Hamdi and E. Srasra, "Removal of phosphate ions from aqueous solution using Tunisian clays minerals and synthetic zeolite," *J. Environ. Sci.*, vol. 24, no. 4, pp. 617–623, 2012, doi: 10.1016/S1001-0742(11)60791-2.
- [26] R. Bassam *et al.*, "Studies on the Removal of Cadmium Toxic Metal Ions by Natural Clays from Aqueous Solution by Adsorption Process," *J. Chem.*, vol. 2021, 2021, doi: 10.1155/2021/7873488.
- [27] A. Battas, A. El Gaidoumi, A. Ksakas, and A. Kherbeche, "Adsorption study for the removal of nitrate from water using local clay," *Sci. World J.*, vol. 2019, 2019, doi: 10.1155/2019/9529618.
- [28] P.-T.-L. R. Mathieu D, Nony J, "New Efficient Methodology for Research using Optimal Design (NEMROD)." Software – L.P.R.A.I, Univ. Aix-Marseille III, France, 1998.
- [29] J. Goupy, "Experimentals design," *Rev. Modul.*, vol. 34, pp. 74–116, 2006, [Online]. Available: <http://www.modulad.fr/archives/numero-34/Goupy-34/goupy-34.pdf>.
- [30] Vaillé J and Goupy J, "Build and interpret a complete factorial design," *Rev. Modul.*, vol. 35, pp. 1–

5, 2006.

- [31] N. R. Draper and G. E. P. Box, "Empirical Model-Building and Response Surfaces," *Biometrics*, vol. 46, no. 1, pp. 283–284, 1990.
- [32] A. M. Joglekar and A. T. May, "Product excellence through design of experiments," *Cereal Foods World*, 32, 857–868, vol. 32, pp. 857–868, 1987.
- [33] A. Lambert, P. Drogui, R. Daghbir, F. Zaviska, and M. Benzaazoua, "Removal of copper in leachate from mining residues using electrochemical technology," *J. Environ. Manage.*, vol. 133, pp. 78–85, 2014, [Online]. Available: 10.1016/j.jenvman.2013.11.036.

UNDER PEER REVIEW