

# IoT-Based Automated Solar Panel Cleaning and Monitoring Technique

---

## ABSTRACT

**Aims:** The objective of this research work is to design and develop an IoT-based automated solar panel cleaning and real-time monitoring system using a microcontroller to improve the output and efficiency of a solar module **at a low cost**.

**Study design:** Most of the time, dust over solar panels creates a barrier that obstructs the sun's radiation and reduces their performance. As such, it is necessary to keep the solar panel clean to improve output power levels. We integrated the IoT technology along with a range of components, including a microcontroller, a NodeMCU, a servo motor, a DC motor-driven submersible pump, a Light Dependent Resistor (LDR), an LCD with driver IC, etc. to design the system. We developed the assembly language program for the microcontroller.

**Place and Duration of Study:** The work was conducted individually under the supervisor of a faculty member as a part of the final project work of the Master of Engineering degree in Electrical and Electronic Engineering at American International University Bangladesh (AIUB), Dhaka, Bangladesh. The student conducted his research work at AIUB for two consecutive semesters from September 2022 to May 2023.

**Methodology:** An LDR sensor detects the solar panel's dirtiness and triggers the cleaning process through the microcontroller. The system monitors this continuously and real-time vital data is accessible to have some performance metrics, empowering timely maintenance actions to be triggered by the system and hence ensuring the maximum power output. The automated cleaning mechanism, driven by servo motors and mini submersible DC motor pumps, effectively removes dust and dirt from solar panels. An application was used to get real-time data through the internet to the user's smartphone.

**Results:** The server data is accessed to observe the system performance. The cost analysis shows that this system offers a cost-effective and sustainable solution for maintaining clean solar panels and optimizing power output.

**Conclusion:** Such an automation system can contribute meaningfully to the progression of renewable power generation by significantly improving the efficiency and longevity of solar panels. Thus, we can have sustainable and efficient energy systems in the country by integrating IoT-based automation systems.

*Keywords: Automation, Solar Panel Cleaning, Renewable Energy, Microcontroller, IoT.*

## 1. INTRODUCTION

Solar panels for electricity generation have become popular in recent years due to their low cost and environmental benefits [1-2]. One of the major issues that solar panel users face is the gathering of dirt, dust, and other debris on the plane of the solar panels. Since multiple cells are connected in series in a solar photovoltaic panel, if one cell is blocked by dirt or dust then the whole panel output reduces and as a result, reduces the efficiency of the panel [3]. Therefore, regular cleaning is required to maintain optimal performance and extend the lifespan of solar panels. Thus, this research work proposes an IoT-based and microcontroller-operated automated solar panel cleaning and power monitoring system to address this problem, because IoT is a state-of-art technology for any monitoring system and a microcontroller was found very suitable in many application areas [4-8].

This paper is organized into six more sections, Section 2 reviews the literature, Section 3 explains experimental methods with a block diagram, Section 4 contains a simulation model, Section 5 shows the flow chart for the program development, Section 6 presents results and discussions, and Section 7 provides concluding remarks and suggests for future scopes.

## 2. LITERATURE REVIEW

The solar energy generation is increasing each year. According to the **International Renewable Energy Agency (IRENA)** report, it went over 1 million gigawatt-hours in the world in 2021, and in Asia, it is growing very fast [9]. Currently, the world's solar power production capacity is 850.2 GW with only 4.4% of the global electricity demand. As such, the number of solar panels is also increasing day by day to meet most of the electricity demand from solar power. It was estimated that to generate adequate power to meet the entire USA, it would take nearly 18.5 billion solar panels [10]. However, due to several reasons, dust is deposited onto the surfaces of the solar panels and thus reduces the output power and the panel efficiency. Various researchers found 12.4-30.4% of performance reduction because of this dust accumulation [11-12]. Hence, cleaning methods play an important part in upgrading the output power and efficiency of solar panels [13]. Therefore, the subject of cleaning photovoltaic modules has been studied for many years. In recent years, various methods for cleaning solar panels have already been proposed and researched by researchers [14].

One of these methods is to manually wash the plate using water and a soft bristle brush. However, this method can be time-consuming and requires special equipment and training. An earlier study compared the performance of manually cleaned solar panels with those cleaned by a robotic system and found that the robotic system was more efficient in terms of energy harvesting [15]. In addition to cleaning, monitoring the output of solar modules is also an important aspect of solar module maintenance. Several studies have shown that real-time monitoring of solar panel performance can help identify and troubleshoot problems, such as shading, pollution, and other factors that can affect performance [16]. **Kumar et al. proposed** a wireless sensor network-based system for monitoring solar panel performance. This is effective in detecting faults and improving overall system efficiency [17].

One study by **Zhou et al. proposed** an AI-based solar panel cleaning system that uses machine learning algorithms to detect the level of soiling on the panels and optimize the cleaning process accordingly. The study showed that the proposed system was more efficient and cost-effective than traditional cleaning methods [18].

Another study by **Tewari et al. proposed** an IoT-based solar panel monitoring and cleaning system that uses a combination of sensors, actuators, and machine learning algorithms to detect and address issues in real time. The study showed that the proposed system was effective in improving energy yield and reducing maintenance costs [19].

A study by **Bhat et al. proposed** a solar panel cleaning and monitoring system that uses drone technology to clean and inspect the panels. The study showed that the proposed system was effective in reducing cleaning time and improving the accuracy of inspections [20].

In addition to cleaning and monitoring, some studies have focused on developing self-cleaning solar panels that can reduce maintenance requirements. A study by **Kippelen et al. proposed** a self-cleaning solar panel that uses a hydrophobic coating to repel water and prevent dust accumulation. The study showed that the proposed panel had a higher efficiency and a longer lifespan than traditional panels [21].

Overall, previous research has shown that regular cleaning and monitoring of solar panels are essential for maintaining their performance and extending their lifespan. The proposed IoT-based automated solar panel cleaning and power monitoring system aims to address these issues by providing an efficient, cost-effective, and automated solution for solar panel dust detection and cleaning methods.

### 3. EXPERIMENTAL METHODOLOGY

The mechanism of analyzing the IoT-based automated solar panel cleaning and monitoring system involves comprehending the working principles of each component that constitutes the system. The objective of the system is to automate the cleaning of the solar panel and monitor the power produced. The complete block diagram of the system is given in Fig. 1.

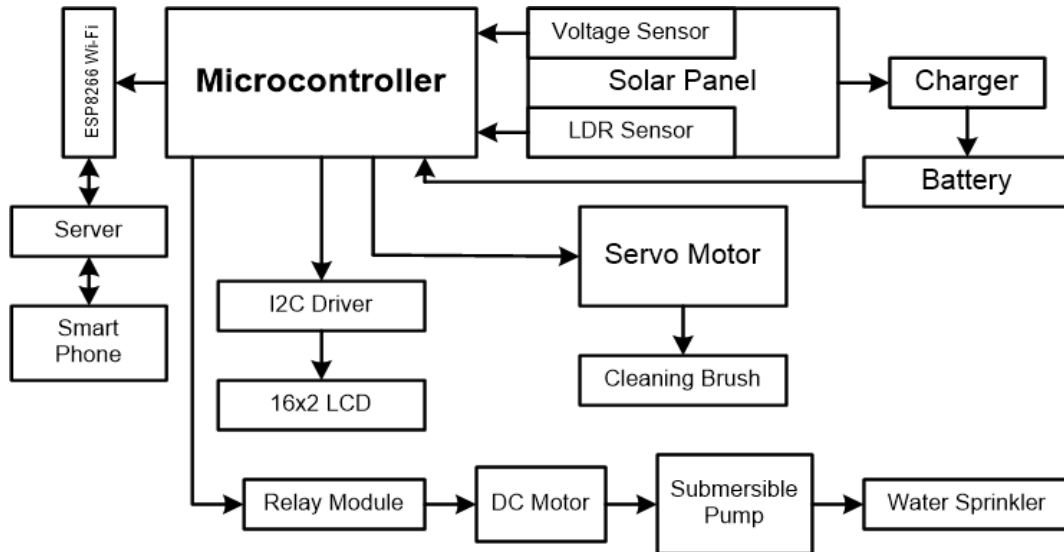

Fig. 1. Block diagram of an IoT-based automated solar panel cleaning scheme.

According to this block diagram, the solar panel produces electrical power from the sun's light energy and the battery stores that power through the charger. However, the output power level depends on the extent of dust and dirt aggregated on the exterior of the panel.

The NodeMCU is then attached to collect data from the solar panel's output of the voltage and LDR sensors. The Arduino microcontroller is connected to the I2C LCD driver, which displays the data collected from the solar panel. The cleaning brush is connected to the servo motor's output shaft to clean the solar panel's surface. The submersible pump is linked to the water reservoir so that it can spray water on the solar panel when it gets dirty. The submersible pump is driven by a DC motor, which is activated by a relay module. The relay module gets the excitation signal from the microcontroller based on the cleaning requirement.

The voltage sensor detects the voltage level of the solar panel and the LDR sensor detects the amount of sunlight falling on it. Thus, the LDR sensor gives a signal to the microcontroller regarding the intensity level of the sunlight. So, if the solar panel's output voltage level falls below a specified threshold level, then the microcontroller can detect whether the solar panel is dirty or not by comparing the detected voltage levels of these two sensors. The system is programmed to activate the water pump and cleaning brush based on this comparison. The servo motor alternately turns the cleaning brush, while the submersible DC motor-driven pump lifts water from the reservoir to the solar panel for cleaning. The system is connected to the cloud server via an IoT to ensure that the user can monitor the system's performance remotely and make necessary adjustments. It helps in collecting data from the solar panel, monitoring the voltage generated, and automating the cleaning process. The reasons for using various components are explained in the next sub-sections.

#### 3.1 NodeMCU

The NodeMCU based on the ESP8266 Wi-Fi module is used in this work to integrate different components connected via various sensors and devices to have a robust network. It has voltage regulators, USB to serial converters, numerous input/output pins, etc. It can accommodate diverse ranges of sensors readily and supports the Arduino IDE platform to write programming languages for it [22]. The NodeMCU is responsible for collecting data from the solar panel and transmitting it to the LCD device for visualization.

### **3.2 Li-Ion Rechargeable Battery**

Lithium-ion (Li-ion) rechargeable battery is used in this work because it is very eco-friendly, possesses very high energy density, and lower rates of self-discharge. During the discharging and recharging cycles, it undergoes movement of charged particles through cathodes and anodes to create current flow. Therefore, it can be reused several times. So, it provides a cost-efficient long-term solution. Besides, it is a lightweight and safe device for its users [23-24].

### **3.3 Solar Panel**

In this work, a monocrystalline mini solar panel was used having a battery capacity of up to 200mAh at 6 V to test our designed system's functionality. The panel converts light radiation from the sun into usable electricity. It produces more energy per square inch. It can deliver electric power over extended periods, even when direct sunlight is unavailable [25].

### **3.4 Relay Module**

Controlling any device driven by high voltage and current requires low voltage and current signals. In such cases, the relay module is highly effective [26]. It works like an electrical switch that opens or closes mechanical or magnetic circuits to regulate electricity flow at high voltage and high current. A control circuit processes the control signals to activate relays. In this work, we used a relay module of 5 V DC to 250 V AC having an AC rating of 10 A and a response time of around 1  $\mu$ s. It serves as a switch to turn the DC motor ON and OFF.

### **3.5 Submersible Pump**

A mini submersible DC motor pump was used in this work to lift water from the underground reservoir during the solar panel cleaning process. This type of small-sized and robust pump consumes very low power at high efficiency and can pump water without priming. These pumps are manufactured to provide increased lifespan and high performance. It can pump up to 120 liters of water per hour with a very low current intake of around 220mA [27-28].

### **3.6 DC Servo**

A DC servo is a kind of rotary actuator, containing a DC motor, a gear train, an integrated circuit, a potentiometer, and an output shaft, used for precise control and movement of an object to a specific position. In this work, a DC servo is used to position and move the cleaning brush to clean the solar panel surface completely and effectively. The DC servo motor rotates the cleaning brush backward and forward. The used DC servo has a stall torque of 1.8 kg.cm at an operating DC voltage of 4.8 V [29].

### **3.7 LCD Device and Driver**

The LCD is widely used to present vital information, including sensor readings, system status, messages, and menu options. It provides a simple and cost-effective way to visually present data to the user [30]. In this work, an LCD was used having the capacity of displaying 16 characters in 2 lines. To connect the LCD screen to the microcontroller, we used an Inter-Integrated Circuit (I2C) LCD driver module, which communicates via I2C protocol. This module requires no complex connections or setup, thus saving time [31].

### 3.8 Sensor

The Light-Dependent Resistor (LDR) sensor, which changes its resistance based on the light intensity on its surface, is used to sense the dust on the solar panel. If dust is present, then the surface is less exposed to light and hence the LDR resistance increases. If the thickness of dust is higher, then the LDR resistance is higher, because dust particles resist the light passing through it. Therefore, LDRs are useful for detecting the amount of dust particles accumulated on the solar panel's surface. That is, this sensor cannot only detect the presence or absence of light but also can measure its intensity. Thus, LDRs are employed in this task to trigger an action when a certain threshold value of light intensity is attained [32].

## 4. SIMULATION MODEL

Fig.2 represents the simulation model of the system, which is developed by using the Proteus professional simulation software. Arduino Uno is used as a microcontroller. A virtual terminal is used for showing the IoT's outputs. Two motors, connected to the Arduino Uno's output terminals, represent the servo motor and DC motor, respectively. To detect dust and time, two LDR sensors are connected to the input terminals. An LCD is connected to the output terminals through an I2C LCD driver to show the output status.

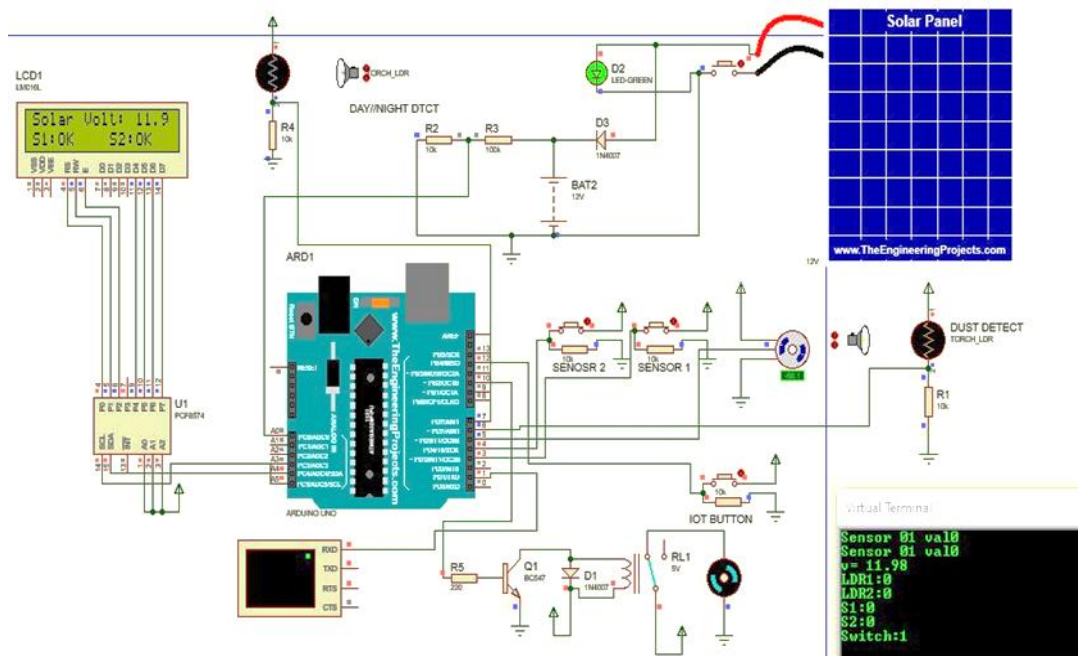

**Fig.2. Simulation model of an IoT-based automated solar panel cleaning and monitoring arrangement in Proteus simulation environment.**

## 5. FLOW CHART

The flow chart of the IoT-based automated solar panel cleaning scheme is shown in Fig. 3. As per the flow chart, the program initializes the variables at the start of the system. Then it scans the input ports of the microcontroller to read the LDR and voltage sensors' data. After that, the data is analyzed by the microcontroller according to its assembly language program. If it detects a HIGH signal, then the program sends HIGH signals to both output terminals connected to the servo and DC motors. The servo motor actuates the cleaning brush, and the DC motor is activated via a relay module to spray water on the solar panel. However, if no dust is detected, then the program remains in the loop of scanning the two sensors' data.

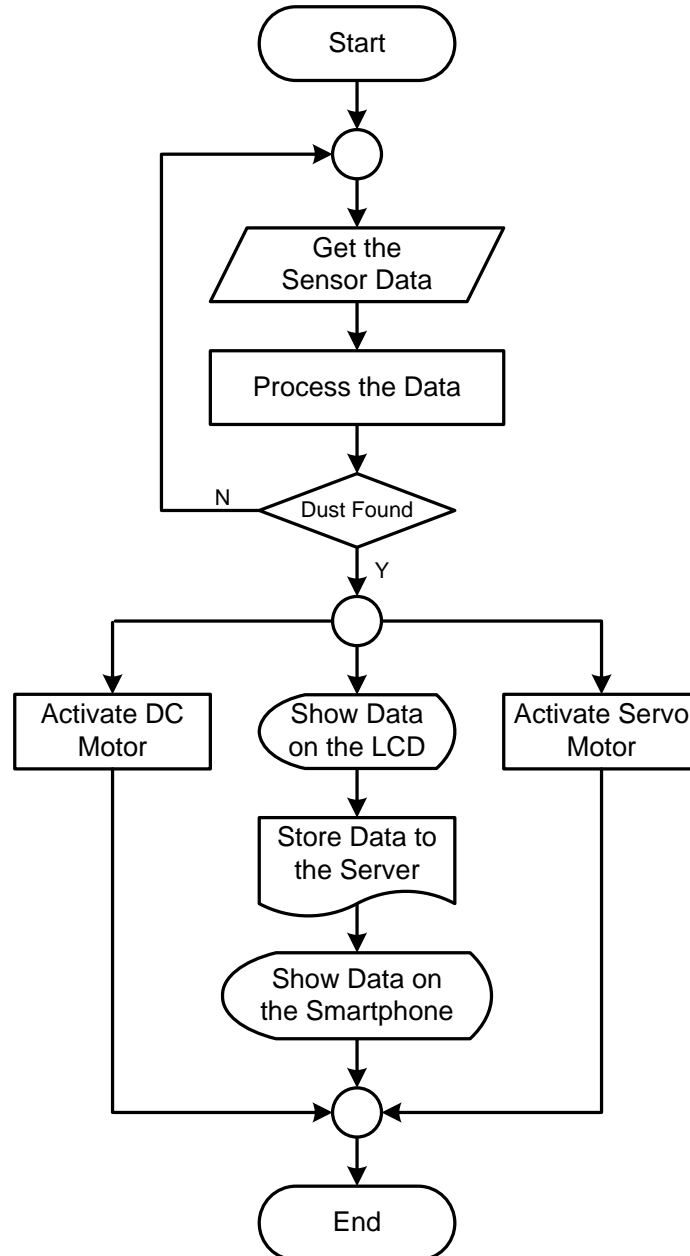
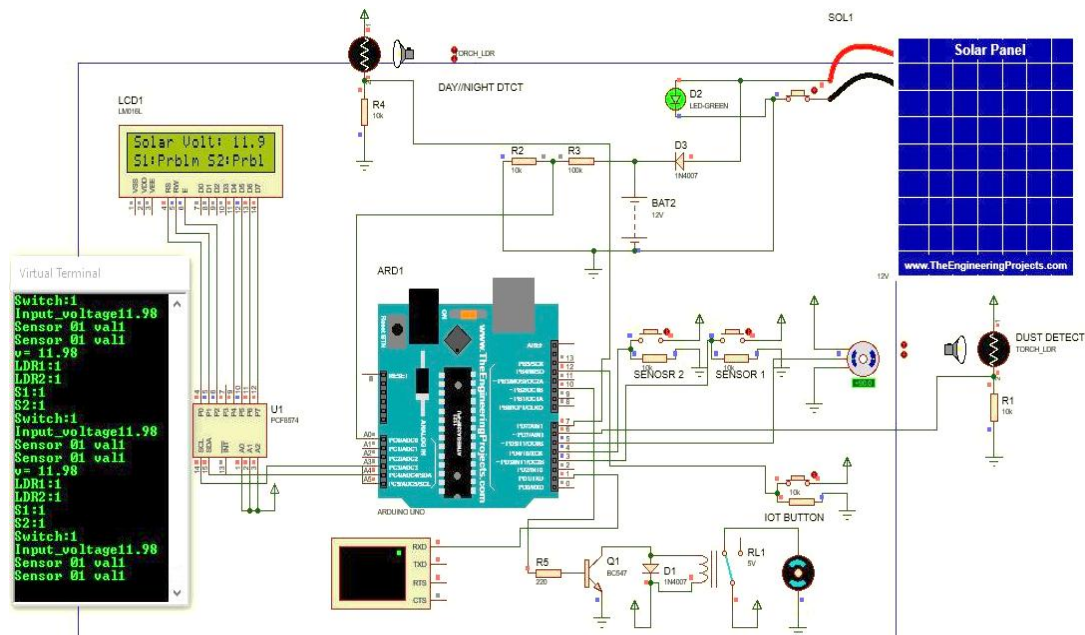

**Fig.3.Flow chart of an IoT-based automated solar panel cleaningarrangement.**  
**6. RESULTS AND DISCUSSIONS**

The results are shown in various figures in the following four sub-sections:

**6.1 Simulation of Proteus Model**

The proposed simulation model is simulated in Proteus simulator and the outputs are shown in Figs. 4-7. Fig. 4 shows the outcome on the LCD screen and the virtual terminal. It shows the generated voltage from the PV panel (it is 11.9 V) and the branch connection status (both branches have problems). Besides, it shows the statuses of the LDR and voltage sensors, switch statuses, etc. Since both sensors have problems, there is no angle of rotation of the DC motor has been observed in Fig. 4.



**Fig.4.Generated voltage by the panel and branch connection status.**

Fig. 5 shows another output combination of output voltage (it is 11.9 V) and branch connection status (one has a problem and another one is without a problem) on the LCD screen and virtual terminal representing an IoT monitoring interface. This is shown by the positions of the switches in Fig. 5 (the switch of sensor 2 is closed and the switch of sensor 1 is opened). The closed relay contact at the bottom indicates that the DC motor for the submersible pump has rotated by some angle.

Fig. 6 represents the output combination of output voltage (it is 11.9 V) and branch connection status (one has a problem and another one is without a problem) on the LCD screen and virtual terminal. This is shown by the positions of the switches in Fig. 6 (the switch of sensor 1 is closed and the switch of sensor 2 is opened). The DC motor for the pump has also rotated by some angle.

Fig. 7 represents the output combination of output voltage (it is 11.9 V) and the statuses of the branch connections (both have no problem) on the LCD screen and virtual terminal. This is shown by the positions of the switches in Fig. 7 (switches of sensors 1 and 2 are closed). In this case, both the DC servo and pump motors have rotated by some angle.

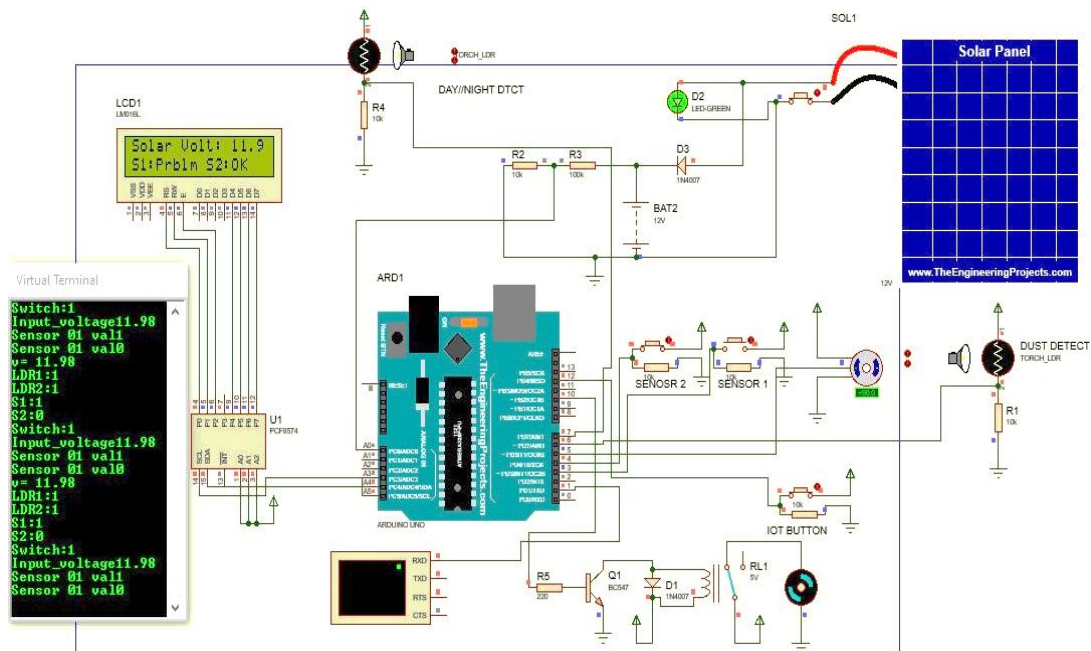

Fig.5.Generated voltage by the panel, branch connection status, and motor rotation.

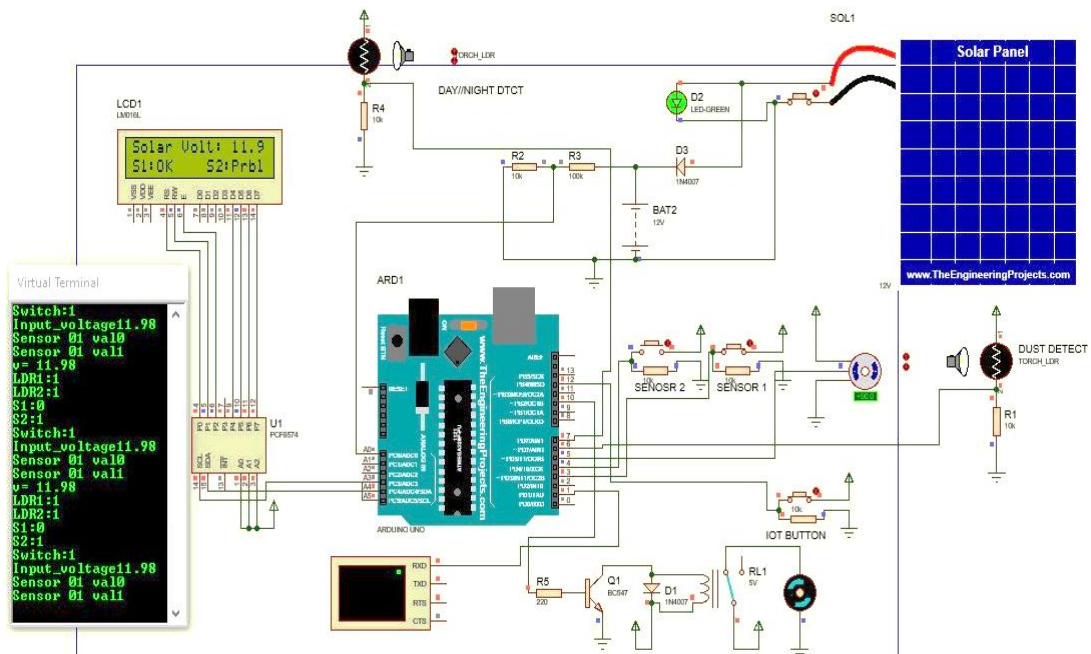

Fig. 6.Generated voltage by the panel, branch connection status, and motor rotation.

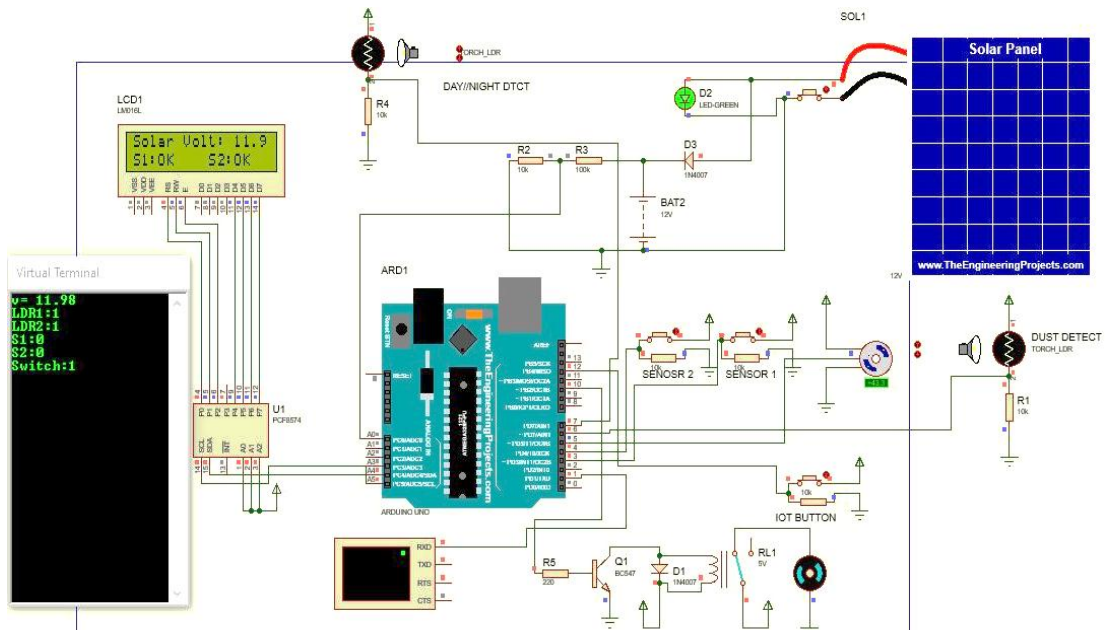

Fig. 7. Generated voltage by the panel, branch connection status, and motor rotation.

## 6.2 Hardware Implementation

Fig.8 shows the physical implementation of an IoT-based automated solar panel cleansing and monitoring technique. The hardware system uses various parts described in section 3.

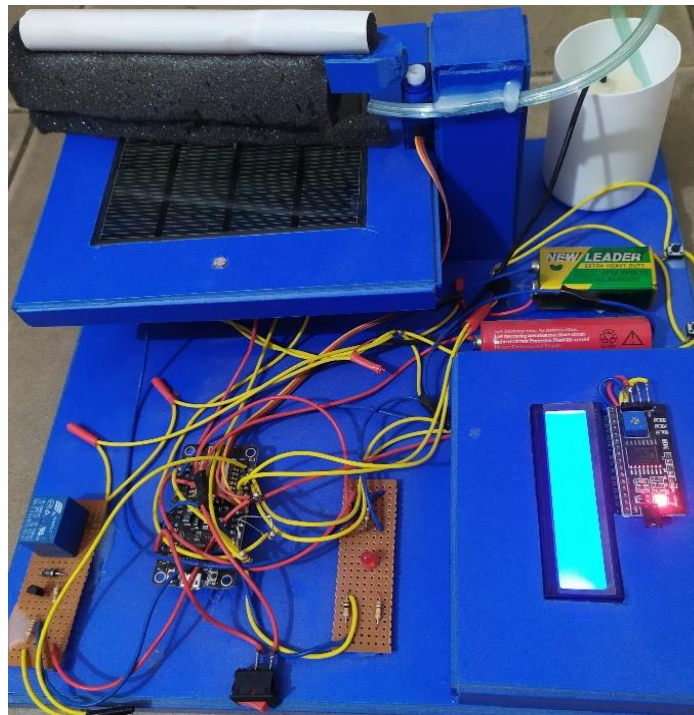
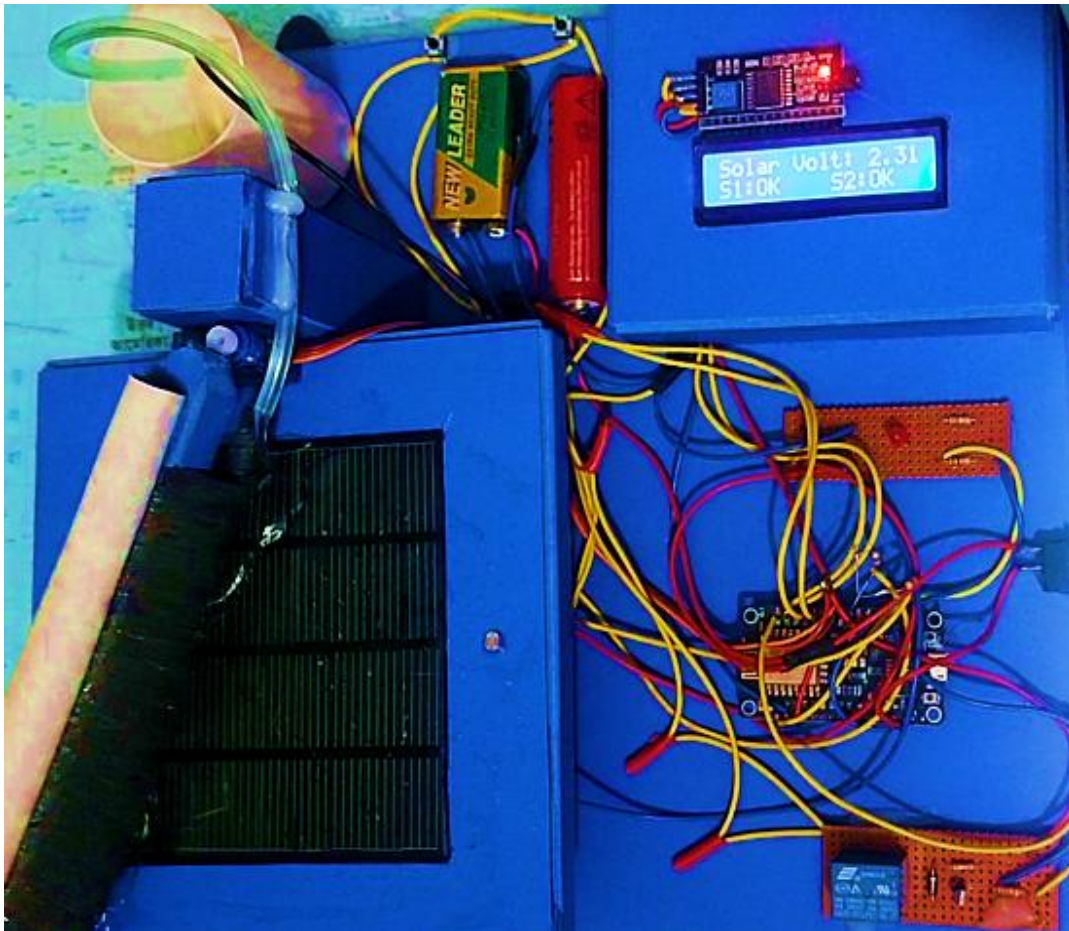

Fig. 8. Physical implementation of an IoT-based automated solar panel cleansing and monitoring technique.

Fig. 9 shows the water reservoir with the pump and servo motors with a cleaning brush. The cleaning brush sweeps the panel with the DC servo motor and the pump motor sprays the water onto the panel's surface to clean it. The LCD screen shows the generated output voltage as 2.31 V.



**Fig. 9. Water reservoir with the pump and servo motors with a cleaning brush.**

The LCD screens of Fig. 10 show the generated output voltage from the PV panel and branch connection statuses of the real-time system. When a short circuit or disconnection occurs then the problem at the corresponding branch status is displayed on the LCD screens including the output voltages. In the first two figures, one bus has a problem and another one has no problem, but the third image shows that both buses are free from any problems. The generated output voltages are 2.42 V, 2.36 V, and 2.74 V, respectively.



**Fig.10. Generated voltage and branch connection statuses on the LCD screen.**

### 6.3 IoT Implementation

The Blynk IoT interface used in this work is shown in Fig. 11. It is an IoT server that provides free IoT App server facilities.

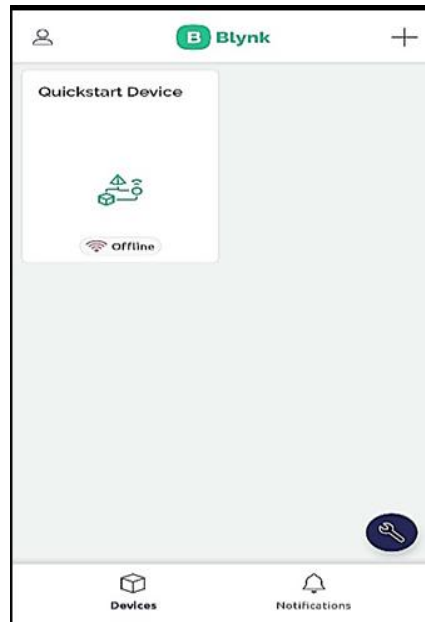

Fig.11.Interface of the Blynk IoT Apps for the monitoring purpose of the system.

Fig.12 shows the IoT server monitoring interface from where the generated voltage status and connection status can be monitored. If the automated cleaning system does not work properly, then it can be handled manually by using the ON/OFF button of the interface displayed on the smartphone's screen. This screen shows the OFF condition as a red color circle and the ON condition as a white color circle. The generated output voltages of the solar panel at various conditions are 2.417 V, 1.772 V, 2.417 V, and 2.256 V, respectively for various signals detected by sensors 1 and 2.

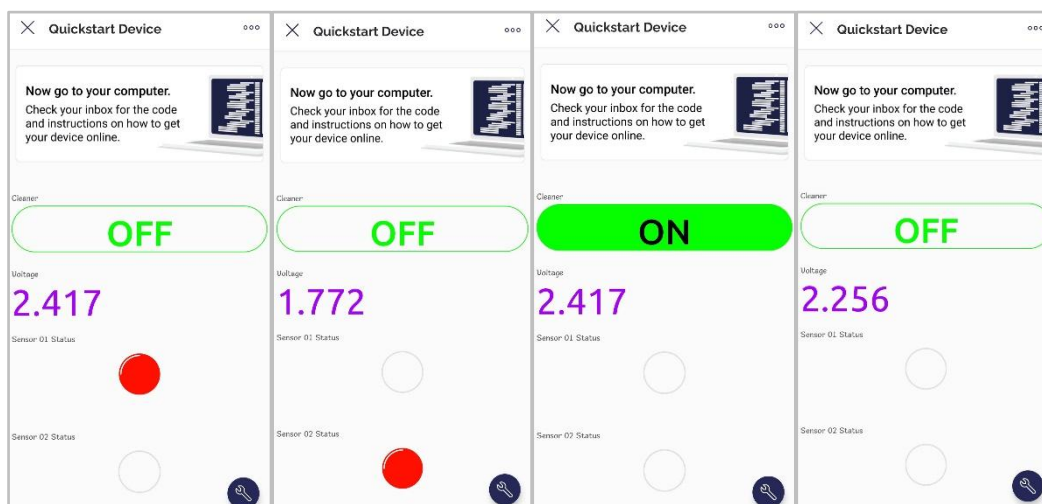

Fig.12. IoT server monitoring interface showing various results.

## 6.4 Cost Analysis and Comparison with the Published Methods

Table 1 shows the breakdown of prices of various components used in this work. The total cost required for this work is BDT3555 (Bangladeshi Taka three thousand five hundred and fifty-five only), which may be approximately equal to US\$33 (US Dollar thirty-three). This system is a very low-cost solution as noted from the cost analysis.

**Table 1. Cost estimation of an IoT-based automated solar panel cleaning and monitoring system.**

Component	Quantity	Cost (BDT)
Node MCU	1	500/-
Solar panel	1	450/-
Relay Module	1	120/-
DC Pump Motor	1	160/-
I2C Driver	1	160/-
LCD	1	280/-
Servo motor	1	160/-
Battery	2	280/-
LED	1	10/-
Diode	2	10/-
Resistor	10	10/-
Capacitor	1	15/-
Switch	1	30/-
PVC Board	-	300/-
LDR Sensor	2	60/-
Transistor etc.	2	10/-
Others	-	1000/-
<b>Total</b>		<b>3555/-</b>

\* Costs are given based on prices of the components in Bangladesh in Bangladeshi Taka (BDT). But it may vary depending on the country of purchase and dollar rate. In general, 1 US\$ = 110 BDT.

Table 2 provides a comparative summary of various literature reviewed in this article. From this comparative analysis, it is found that the proposed system is a low-cost solution.

**Table 2. Comparison among the various automated solar panel cleaning and monitoring systems.**

Parameter of Comparison	Proposed System	Existing System	Reference
Sensor	Voltage and LDR	LDR/WSN	[33]/[15]
Microcontroller	Arduino Uno	Arduino Uno	[33]
Actuator	DC motor and Servo Motor	Gear Motor	[33]
Display	LCD	No	
Use of IoT	Yes	Yes	[33]
Cleaning Method	Water Flow	Air Flow	[33]
Cost	BDT3555/-	BDT6455/-	[33]

## 7. CONCLUSION

The IoT-based automated solar panel cleaning and monitoring system offers an efficient solution for enhancing the solar panel's performance. IoT technology enables the system to automate the cleaning process and monitor voltage and power generation in real-time. This reduces the man-hour, manpower requirement, maintenance cost, and likelihood of any faults or damages to the solar panel during the manual cleaning process. In traditional solar panel systems, manual cleaning methods and continuous monitoring options are limited. However, this automated system can contribute to the advancement of renewable energy technologies by significantly improving the efficiency and longevity of solar panels. Therefore, to get more sustainable and efficient energy systems in the future, we should adopt microcontrollers and IoT-based automation systems to attain some of the Sustainable Development Goals (SDGs) declared by the United Nations (UN). However, this work can be extended further. For example, the system may be integrated with artificial intelligence algorithms to make it more efficient in cleaning and monitoring solar panels. Besides, the system can be integrated with cloud computing to store, process, and manage huge amounts of data produced by the monitoring sensors. Not only that, the integration of robotics in this system can considerably improve the efficiency and speed of the cleaning process, especially for large solar panel installations. The use of more advanced sensor technologies, such as infrared sensors, ultrasonic sensors, and thermal imaging sensors, with the system can help to detect defects or faults in solar panels. Also, the integration of advanced energy storage solutions, such as supercapacitors or high-capacity batteries, can enhance the efficiency of the solar panel system.

## ACKNOWLEDGMENTS

We acknowledge the assistance of the laboratory staff of the Department of Electrical and Electronic Engineering, American International University Bangladesh (AIUB).

## AUTHORS' CONTRIBUTIONS

The first author designed the study with the guidance of the second author as a supervisor of this project work. The first author performed the simulation and hardware implementation of the system. All the authors completed the testing phase of the procedure as well as collecting the data. However, the second author did the analysis and writing of the paper including literature reviews as well as collecting literature. The third author edited the final manuscript.

## REFERENCES

1. Herez A, Ramadan M, Khaled M. (2018). Review on solar cooker systems: Economic and environmental study for different Lebanese scenarios. *Renewable and Sustainable Energy Reviews*, 81, 421–432. <https://doi.org/10.1016/j.rser.2017.08.021>.
2. Hasan A, Dincer I. (2020). A new performance assessment methodology of bifacial photovoltaic solar panels for offshore applications. *Energy Conversion and Management*, 220, 112972. <https://doi.org/10.1016/j.enconman.2020.112972>.
3. Guarav P, Salavi A, Pavane S, Sutar P, Hugar R, Kamble P. (2022). Solar Panel Cleaner Using Vibrator and Air Blower for Desert Location. *International Journal of Advanced Research in Science, Communication and Technology (IJARSCT)*, e-ISSN: 2581-9429. 2(1), 138-145. <https://doi.org/10.48175/IJARSCT-4575>.
4. Bhuyan MH, Sheikh M. (2021). Designing, implementing, and testing of a microcontroller and IoT-based pulse oximeter device. *IOSR Journal of Electrical and*

- Electronics Engineering (IOSR-JEEE), 16(5):series-2, 38-48, e-ISSN: 2278-1676, p-ISSN: 2320-3331. <https://doi.org/10.9734/jerr/2023/v24i2799>.
5. Bhuyan MH, Ali MA, Khan SA, Islam MR, Islam T, Akter J. (2023). Design and implementation of solar power and an IoT-Based pisciculture management system. Journal of Engineering Research and Reports, ISSN: 2582-2926. 24(2),15-27. <https://doi.org/10.9734/jerr/2023/v24i2799>.
  6. Paul NK, Saha D, Biswas K, Akter S, Islam RT, Bhuyan MH. (2023). Smart Trash Collection System – An IoT and Microcontroller-Based Scheme. Journal of Engineering Research and Reports, ISSN: 2582-2926. 24(11), 1-13. <https://doi.org/10.9734/jerr/2023/v24i11849>.
  7. Bhuyan MH, Hasan MT, Iskander H. (2020). Low-cost microcontroller-based ECG machine. International Journal of Biomedical and Biological Engineering (IJBBE),14(7),e-ISSN: 1307-6892.192-199.
  8. Titlee R, Bhuyan MH. (2016). Design, implementation, and testing of ultrasonic high-precision contactless distance measurement system using microcontroller. Southeast University Journal of Science and Engineering (SEUJSE), p-ISSN: 1999-1630. 10(2), 6-11.
  9. Explore trends across various regions and technologies, IRENA (2022), Available online: <https://www.irena.org/Data/View-data-by-topic/Capacity-and-Generation/Regional-Trends>, accessed on 2 August 2023.
  10. 35 Latest Solar Power Statistics, Charts, and Data, <https://theroundup.org/solar-power-statistics/>, retrieved on 6 August 2023.
  11. Lasfar, S. Haidara, F. Mayouf, C. Med Abdellahi, F. Elghorba, M. Wahid, A. Kane, C. S. E. (2021). Study of the influence of dust deposits on photovoltaic solar panels: Case of Nouakchott. Energy for Sustainable Development, ISSN: 0973-0826, 63, 7-15, <https://doi.org/10.1016/j.esd.2021.05.002>.
  12. Zorrilla-Casanova, J. Piliouguine, M. Carretero, J. Bernaola, P. Carpena, P. Mora-López, P. Sidrach-de-Cardona, M. (2011). Analysis of dust losses in photovoltaic modules. World Renewable Energy Congress. Linköping, Sweden. 2985-2992. [https://ep.liu.se/ecp/057/vol11/039/ecp57vol11\\_039.pdf](https://ep.liu.se/ecp/057/vol11/039/ecp57vol11_039.pdf)
  13. Walaman-i, IS. Beem, H. (2022) Design of a Dust Cleaning Machine to Reduce Dust Soiling on Solar PV Panels in Ghana. IEEE Global Humanitarian Technology Conference (GHTC), CA, USA, 481-484, doi: <https://doi.org/10.1109/GHTC55712.2022.9911012>.
  14. Olorunfemi, BO. Ogbolumani, OA. Nwulu, N. (2022) Solar Panels Dirt Monitoring and Cleaning for Performance Improvement: A Systematic Review on Smart Systems. Sustainability. 10920. <https://doi.org/10.3390/su141710920>.
  15. Khalid MR, Uddin MJ. (2018). Real-time monitoring of solar panels using wireless sensor network. Journal of Electrical and Electronics Engineering, 6(2). 63-68.
  16. Inayah I, Hayati N, Nurholis A, Dimiyati A, Prasetya MG. (2022). Realtime Monitoring System of Solar Panel Performance Based on Internet of Things Using Blynk Application, ELINVO (Electronics, Informatics, and Vocational Education), p-ISSN 2580-6424, e-ISSN 2477-2399, 7(2):135-143. DOI: <https://doi.org/10.21831/elinvo.v7i2.53365>.
  17. Kumar D, Singh B, Chandra A. (2017). Wireless sensor network-based system for monitoring and fault detection of solar panels. Proceedings of the International Conference on Inventive Communication and Computational Technologies. 746-752.
  18. Zhou L, Jiang Y, Zhang X, Zhai Y. (2021). An AI-based solar panel cleaning system. Journal of Renewable Energy. 177:275-281.
  19. Tewari A, Sharma A, Bhattacharya S, Singhal M. (2020). IoT-based solar panel monitoring and cleaning system using machine learning algorithms. Proceedings of the International Conference on Computing, Power and Communication Technologies. 1-6.
  20. Bhat MA, Choudhary MA, Ahmad F, Iqbal MA. (2021). Development of drone-based solar panel cleaning and monitoring system. Journal of Renewable Energy, 173:855-864.

21. Kippelen B, Faria LJ, de Oliveira LFC, Lago EC, de Oliveira HL. (2020). Hydrophobic coating for solar panels: A study of water repellency and efficiency. *Journal of Renewable and Sustainable Energy Reviews*. 130:109926.
22. Aqeel A. (2018). Introduction to NodeMCU V3 - The Engineering Projects. *The Engineering Projects*, <https://www.theengineeringprojects.com/2018/10/introduction-to-nodemcu-v3.html>, retrieved on 16 August 2023.
23. Used Lithium-Ion Batteries, US EPA. USA EPA, 16 May 2019. <https://www.epa.gov/recycle/used-lithium-ion-batteries>, accessed on 16 August 2023.
24. What Are Lithium-Ion Batteries? UL Research Institutes. 14 September 2021. <https://ul.org/research/electrochemical-safety/getting-started-electrochemical-safety/what-are-lithium-ion>, retrieved on 16 August 2023.
25. Mini-Sized Solar Panel Module 6V 1W Solar System. [Online]. Available: <https://www.aliexpress.com/item/1005001664159872.html>, retrieved on 10 July 2023.
26. GEP Power Products. What is a Power Relay Module? Relay Modules [Online]. Available: <https://www.geppowerproducts.com/standard-products/power-distribution-fuse-relay-holders-fuse-blocks/relay-modules/>, retrieved on 14 August 2023.
27. Potential Labs. Submersible Pump Mini. India. [Online]. Available: <https://potentiallabs.com/cart/Buy-micro-dc-3-6v-submersible-pump-mini-water-pump-online-hyderabad-india/>, retrieved on 16 August 2023.
28. Mini Submersible DC Motor Pump. ThinkRobotics.com. India. [Online]. Available: <https://thinkrobotics.com/products/mini-submersible-dc-motor-pump>, retrieved on 18 August 2023.
29. TowerPro SG90 Mini Servo Motor. RoboTech Valley. [Online]. Available: <https://store.robotechvalley.com/product/towerpro-sg90-mini-servo-motor/>, retrieved on 16 August 2023.
30. Hackster.io. Interface 16x2 LCD (parallel interface) with Arduino Uno. Hackster.io. [Online]. Available: <https://www.hackster.io/akshayjoseph666/interface-16x2-lcd-parallel-interface-with-arduino-uno-2e87e2/>, retrieved on 17 August 2023.
31. Naba Tech Shop. I2C LCD Display Driver – Naba Tech Shop. [Online]. Available: <https://nabatechshop.com/product/i2c-lcd-display-driver/>, retrieved on 17 August 2023.
32. Robocraze. (2022). What is the LDR Sensor - Working principle, Applications, Advantages. Robocraze, [Online]. Available: <https://robocraze.com/blogs/post/what-is-the-ldr-sensor>, retrieved on 17 August 2023.
33. Habib MR, Tanvir MS, Suhan AY, Vadher A, Alam S, Shawmee TT, Ahmed K, Alrashed A. (2021). Automatic Solar Panel Cleaning System Based on Arduino for Dust Removal. International Conference on Artificial Intelligence and Smart Systems (ICAIS), Coimbatore, India. 1555-1558. doi: <https://doi.org/10.1109/ICAIS50930.2021.9395937>.