

Short Research Article Enhancing Gaming Performance A Recommender System for Selecting Optimal Gaming Headsets Based on SAW Method

ABSTRACT

Aims: The objective of this research is to design and develop a gaming headset recommendation system using the Simple Additive Weighting (SAW) algorithm based on a website. Additionally, the goal is to obtain user satisfaction ratings for the gaming headset recommendation system using the SAW algorithm, based on the End-User Computing Satisfaction (EUCS) model

Study design: This study was designed with Simple Additive Weighting method to build a gaming headsets website

Place and Duration of Study: Department of Informatic Universitas Multimedia Nusantara, between September 2022 to July 2023.

Methodology: In this research, the method designed is the Simple Additive Weighting (SAW) method, which aims to facilitate users in making the right decisions regarding gaming headsets. The SAW method provides a straightforward approach for evaluating and comparing multiple criteria to assist users in their decision-making process.

Results: Based on the conducted test results, there is a user satisfaction rate of 83.35% based on the End User Computing Satisfaction (EUCS) model, indicating that users strongly agree with the system.

Conclusion: The gaming headset recommendation system has been successfully designed and built using the Simple Additive Weighting (SAW) method. This system functions to recommend gaming headsets based on the comparison of six criteria: weight, price, driver size, frequency response, impedance, and sensitivity, according to user preferences. The system is developed on a web platform using the PHP Laravel framework.

Keywords: Gaming Headset Recommendations, Simple Additive Weighting, enduser computing satisfaction, Decision Support System

1. INTRODUCTION

In recent years, there has been a notable surge in the popularity of electronic esports, prompting individuals across various age groups, including children, teenagers, and adults, to actively engage in the realm of gaming. When engaging in gaming activities, it is necessary to utilize supplementary gaming accessories that serve the purpose of enhancing performance and providing assistance during gameplay. In addition to the primary components, supplementary peripherals like as gaming headsets, mouse, and keyboards are also available [1], [2].

While individuals who solely engage in gaming may not consider these supplementary accessories essential, they hold significant importance for dedicated gamers [3]. Each accessory offers additional features that enhance gamers' performance and facilitate the

maintenance of stable gameplay. Headset accessories hold significant importance as supplementary components for individuals engaged in gaming activities [4]. In addition to enhancing gaming performance, gaming headphones provide the capability to automatically generate high-quality sound, thereby facilitating the detection of enemy movements during gameplay and ensuring an optimal listening experience for music enthusiasts [5], [6].

There exists a range of gaming headset models catering to the preferences of gamers. However, within the gaming community, the specific model of a gaming headset holds relatively less significance compared to the functions it offers. These features are considered crucial when evaluating the quality and suitability of a gaming headset. The Active Noise Canceling (ANC) feature is commonly found in the majority of gaming headsets [7]. However, it is important to note that the amount of ANC may vary across different brands and models of gaming headsets. The primary purpose of Active Noise Cancellation (ANC) is to attenuate or eliminate external sounds from penetrating the auditory experience of headset users, hence preventing the perception of sounds or activities occurring outside the headset [8], [9].

According to the findings derived from interviews conducted with many sources, it has been ascertained that Mr. Willy, the proprietor of the Edu Computer shop, offers a diverse range of gaming equipment for sale. According to the source, purchasers frequently experience a state of perplexity and prolonged decision-making when selecting a gaming headset. This is attributed to the extensive array of gaming headset models, accompanied by factors such as weight, price, and specifications, which all contribute to the complexity of the decision-making process. The key specifications of a gaming headset include the size of the driver, the frequency response, the impedance, and the sensitivity. Given the specified requirements, it is imperative for potential purchasers to utilize a recommendation system in order to ascertain the most suitable gaming headset for their needs. The author evaluates the recommendation for the gaming headset by considering many data gathered from the shop owner and potential buyers. These criteria include weight, price, driver size, frequency response, impedance, and sensitivity. The authors conducted research in order to develop a system that may offer consumers information recommendations on the selection of gaming headsets based on their preferences, such as weight, price, driver size, frequency response, impedance, and sensitivity. The primary objective of this recommendation system is to enhance user decision-making processes pertaining to gaming headsets.

A recommendation system is defined as a system that facilitates the provision of information suggestions and suggests an item to aid users in making decisions, based on their specific area of interest. The Simple Additive Weighting (SAW) method is a mathematical approach that involves the summation of weighted values [10]–[12]. Next, it is necessary to choose the alternative with the highest weight value for the performance rating across all attributes. The choice matrix normalization procedure is utilized to compare the ratings of all available alternatives [13], [14]. Hence, there exist various alternatives to gaming headsets, including factors such as weight, price, driver size, frequency response, impedance, and sensitivity. The assessment will exhibit enhanced precision and clarity as it is conducted using predetermined criteria and weight values derived from the disseminated questionnaire [15], [16]. This approach ensures that more accurate and optimal outcomes can be obtained for gaming headsets, which will be taken into consideration by users.

The selection of the Simple Additive Weighting (SAW) technique is motivated by its ability to effectively incorporate all relevant criteria and their respective weights into the decision-making process, hence ensuring the provision of appropriate considerations. [17] The SAW (Simple Additive Weighting) approach offers the benefit of efficiently and accurately evaluating criterion, sub-criteria, and their respective weights, utilizing a straightforward

calculation formula that is easily comprehensible [13], [18]. Furthermore, the saw approach offers additional advantages in terms of optimal alternative selection, hence being highly advantageous in the ranking process of the manufacturing of the gaming headset recommendation system [16], [19]. Hence, the researchers employ the SAW (Simple Additive Weighting) method in this study to offer recommendations for gaming headphones and enhance usability for consumers.

Previous studies have not investigated the utilization of the SAW approach in examining gaming headphones. The objective of this gaming headset recommendation system is to potentially supplant computer stores as a source of recommendations, enabling the general public or users to identify gaming headsets that align with pre-established criteria.

Given the contextual framework of the issue at hand, it is desirable to address this matter through the development and construction of a recommendation system for gaming headsets. This system will be designed using the website-based simple additive weighting (SAW) method, with the objective of ensuring that users receive optimal quality that aligns precisely with their specific requirements, without any excess or deficiency.

2. MATERIAL

The Simple Additive Weighting (SAW) method is a process for finding the weighted sum of performance ratings for each alternative. This method can aid in decision-making in various case studies. However, it only provides the highest value as the selected best alternative during the calculation process. The calculations are based on the method used when the chosen alternative meets the predetermined criteria. The SAW method is considered efficient as it requires less time for calculations, thus providing quicker results [2].

This method requires the process of normalizing the decision matrix (X) to a comparable scale with all available alternative ratings. Each attribute rating should obtain dimensional independence, meaning that it has passed the previous matrix normalization process [13]. The following are the steps to solve the Simple Additive Weighting (SAW) method [4].

1. The identification of the criteria to be employed as a point of reference for decision-making, specifically referred to as C_i , can be ascertained.
2. Determining the weight values, denoted as W , for each criterion used.
3. Creating suitability ratings for each alternative and criterion to be used.
4. Constructing a decision matrix based on the criteria (C_i), then normalizing the matrix using equations adjusted according to the attribute type, whether it is a benefit attribute or a cost attribute, resulting in a normalized matrix R . The following formula represents the normalization step of the SAW method. The formula below utilizes the maximum value when attribute j is a benefit attribute, while the formula utilizing the minimum value is used when attribute j is a cost attribute.

$$r_{ij} = \begin{cases} \frac{X_{ij}}{\text{Max } X_{ij}} \\ \frac{\text{Min } X_{ij}}{X_{ij}} \end{cases} \quad (1)$$

Description:

- a. r_{ij} : Normalized performance rating
- b. X_{ij} : Attribute value for each criterion
- c. $\text{Ma}X_{ij}$: Maximum value of the criterion
- d. $\text{Min}X_{ij}$: Minimum value of the criterion

- e. Cost : If the lowest value is considered the best
 - f. Benefit: If the highest value is considered the best
5. The final result is obtained from the ranking order, which involves summing and multiplying the normalized matrix R with the weight vector to obtain the highest value, which is selected as the best alternative or solution. The following formula represents the ranking step of the SAW method. The formula below depicts the ranking stage of the SAW method.

$$V_i = \sum_{j=1}^n W_j r_{ij} \quad (2)$$

Description:

- a. V_i : Final value of the alternative.
- b. W_j : Weight value for each predetermined criterion.
- c. r_{ij} : Normalized performance rating value.

3. METHODOLOGY

The research methodology process is carried out through nine steps, which are problem identification, literature review, data collection, system design, implementation, evaluation, report writing, revision and improvement, and report writing and consultation.

In this process, data flow diagrams (DFD), flowcharts, table relationships, table structures, and system mockups are created. This step is carried out to facilitate the implementation of the system and ensure that the research is clear and well-structured.

Figure 1 represents the Level 0 Data Flow Diagram (DFD) that provides an overview of how the available entities interact with the system being built. This diagram illustrates the data sent by each entity to the system and the incoming/outgoing data returned by the system. There are two main entities, namely the Admin and User. The roles of these entities can be further explained in the Level 1 DFD.

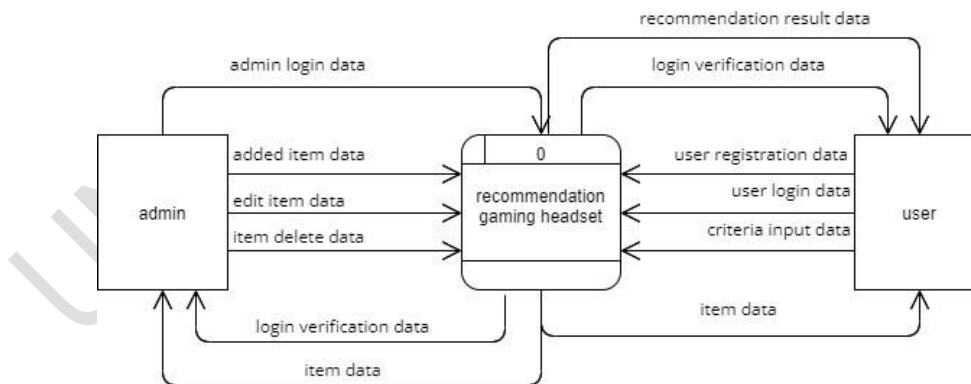

Figure 1 : DFD Level 0

Figure 2 is the Level 1 Data Flow Diagram (DFD) of the Gaming Headset Recommendation System. The Level 1 DFD consists of 8 processes: registration, login, add item, edit item, delete item, view item, input criteria, and recommendation. The flow of item data sends the item data to two entities, namely the admin and user, so that they can view the available item data. The item data is then directed to the final score database to be used in the Simple

Additive Weighting (SAW) calculation. The input criteria process involves users entering criteria based on their specific needs. The flow of criteria data enters the recommendation table and is then forwarded to the final score database for use in the SAW calculation. Users will receive Gaming Headset recommendations based on the calculated data in the final score database. The recommendations will be displayed to the user in descending order based on the highest final score calculated using the SAW method.

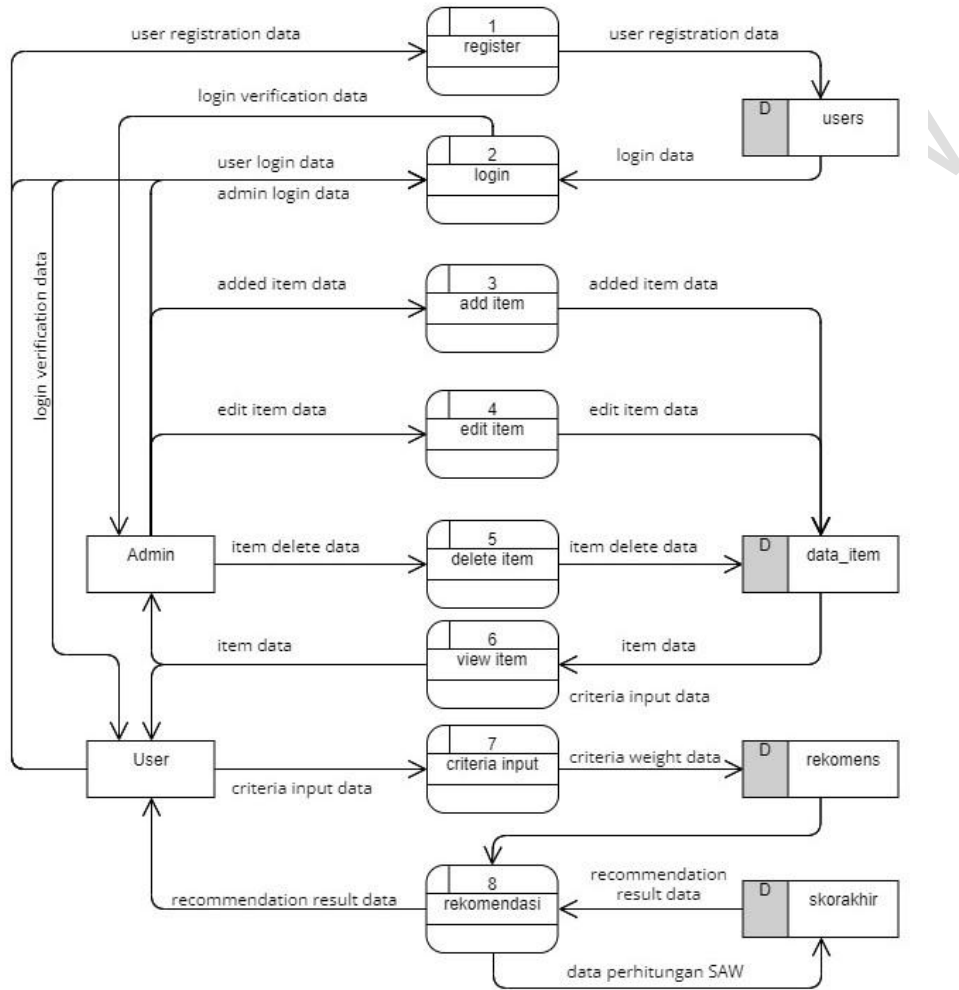

Figure 2 : DFD Level 1

Figure 3 is a flowchart that illustrates the overall flow of the system. It starts with the login page, where users or admins can log in to access their respective main pages. If the user logs in, they will be directed to the user's main page, and if the admin logs in, they will be directed to the admin's main page.

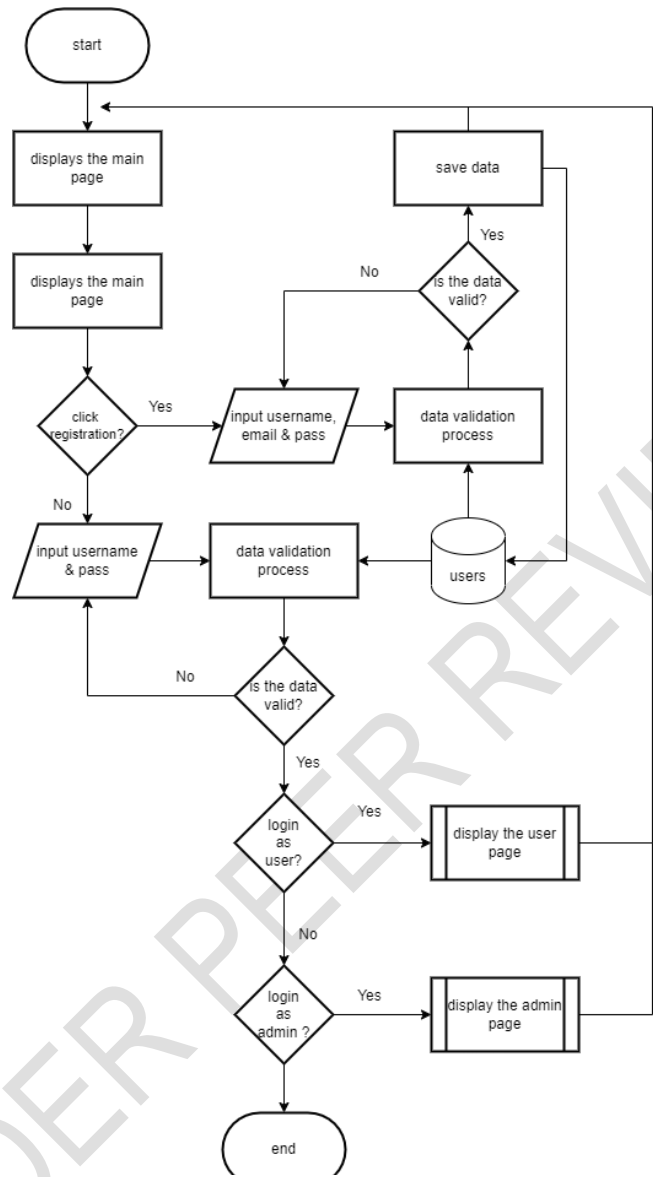

Figure 3 : Main Flowchart

Figure 4 is a flowchart that illustrates the initial user interface flow. It begins with the home page and includes sections such as about page, recommendations page, and items page in the website header.

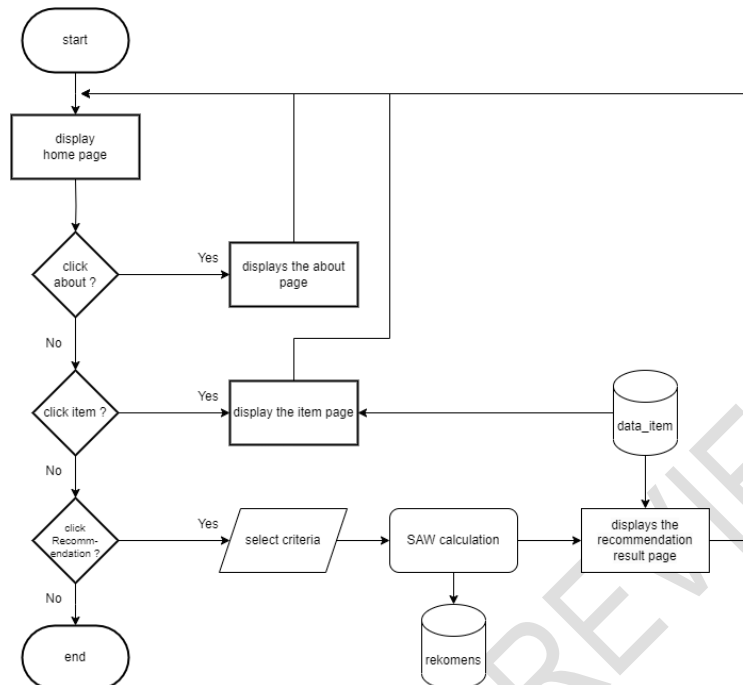

Figure 4 : User Page Flowchart

Figure 5 is a flowchart that illustrates the interface flow from the admin's perspective. It starts with the admin's main page, which includes a dashboard menu and an add item option. On the dashboard page, the admin can edit or delete item data stored in the database. Additionally, the admin can add a new item on the add item page, and it will be automatically saved in the database.

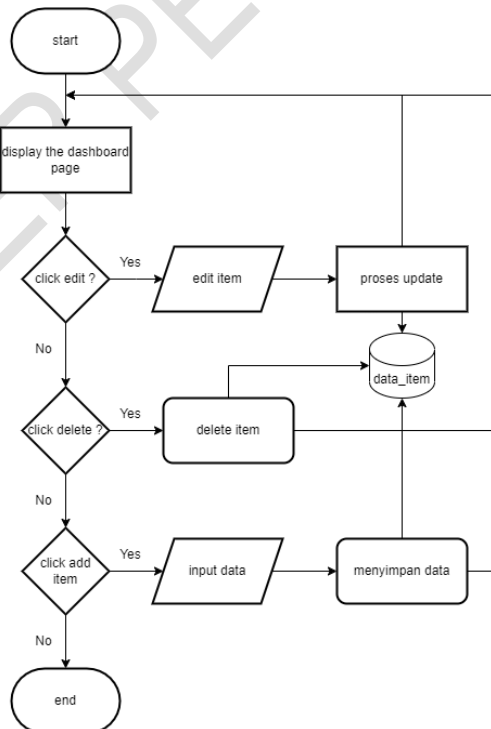

Figure 5 : Admin Page Flowchart

4. RESULT AND DISCUSSION

4.1. System Implementation

In the implementation process of the Gaming Headset Recommendation System, it includes the implementation results of the user interface (UI) that resembles the mockup and the implementation of the Simple Additive Weighting (SAW) method to obtain the best gaming headset.

Figure 6a is the result of the implementation of the register page on the gaming headset recommendation system design, where on this page there is a website name located on the website header, then there is a register form that must be filled in by the user. The function of the register page is to register personal data including username, e-mail, and password. Then there is a register button that functions to save the personal data to the user database, then the user can proceed to the login page.

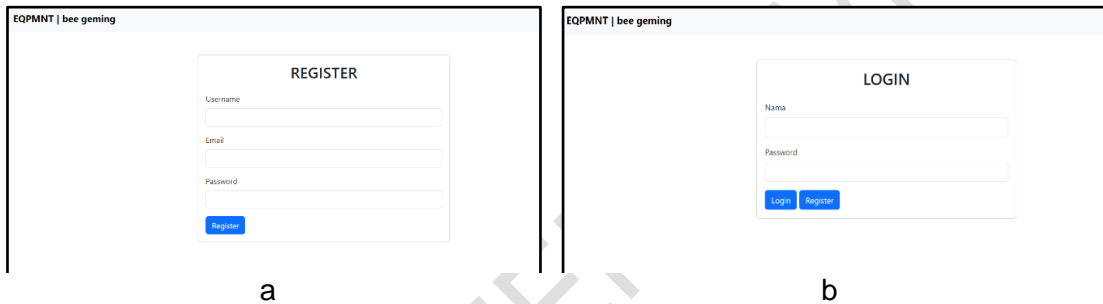

Figure 6 : Register Page and Login Page

Figure 6b is the result of the implementation of the login page on the design gaming headset recommendation system, where on this page there is the name of the website located on the website header, then there are two text boxes that will be filled in by the user/admin, namely username, and password. which will be filled in by the user / administrator, namely username, and password. Then there is login button that serves to enter the main page / dashboard page of the admin. admin.

Figure 7a is the result of the home page implementation. On this page there is a website name, home, about, recommendations, items, and logout located in the website header. Then there is a Hello greeting along with a username that matches the user's username at the time of the previous login, then there is a recommendation button that will directly move to the recommendation page, and a logout button that functions to exit the home page.

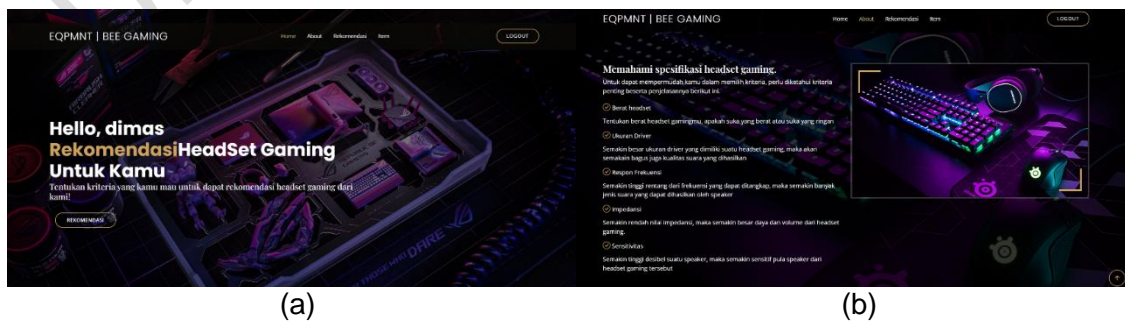

Figure 7 : Home Page and About Page

Figure 7b is the result of the about page implementation. On this page page aims as a guide for users to understand the important criteria contained in a gaming headset. criteria contained in the gaming headset.

Figure 8 is the result of the recommendation page implementation. On the recommendation page recommendation page, there are five text boxes that will be filled in by the user according to the criteria that the user wants. criteria that the user wants, then there is a recommendation button that functions to submit and then the results of the gaming headset recommendation will appear. to submit and then the results of the gaming headset recommendations will appear.



Figure 8 : Reccommendation Page

Figure 9a is the result of the result page implementation. On the result page page will display several items of recommended goods according to the preferences of the user. These items have been sorted according to the highest score to the lowest, then there is a back button that functions to return to the recommendation page. to the lowest, then there is a back button that serves to return to the main page. Figure 9b is the result of the item page implementation. On this item page users can see what items and item details are on the website.

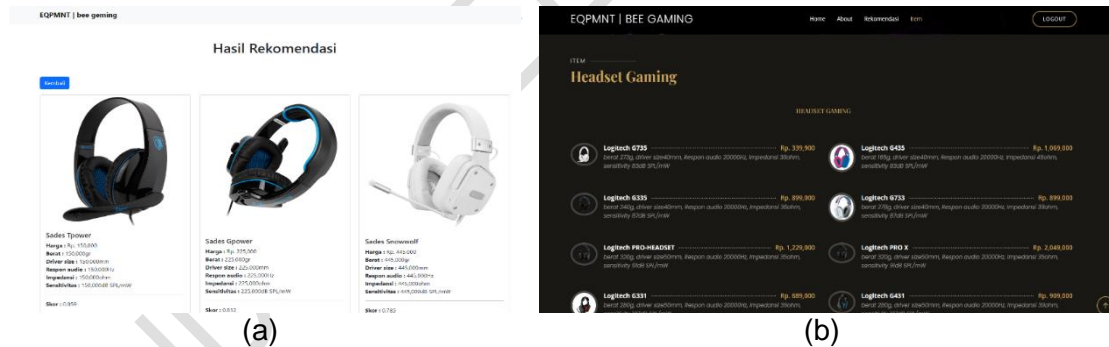

Figure 9 : Result Page and Item Page

Figure 10a is the result of the dashboard page implementation. On this dashboard page the admin can add items to the database, the admin can also edit items and can delete items. Figure 10b is the result of the edit page implementation. On this edit page the admin can change the details of the item selected by the admin, then there is a save button that functions to save the data that has just been changed directly to the database.

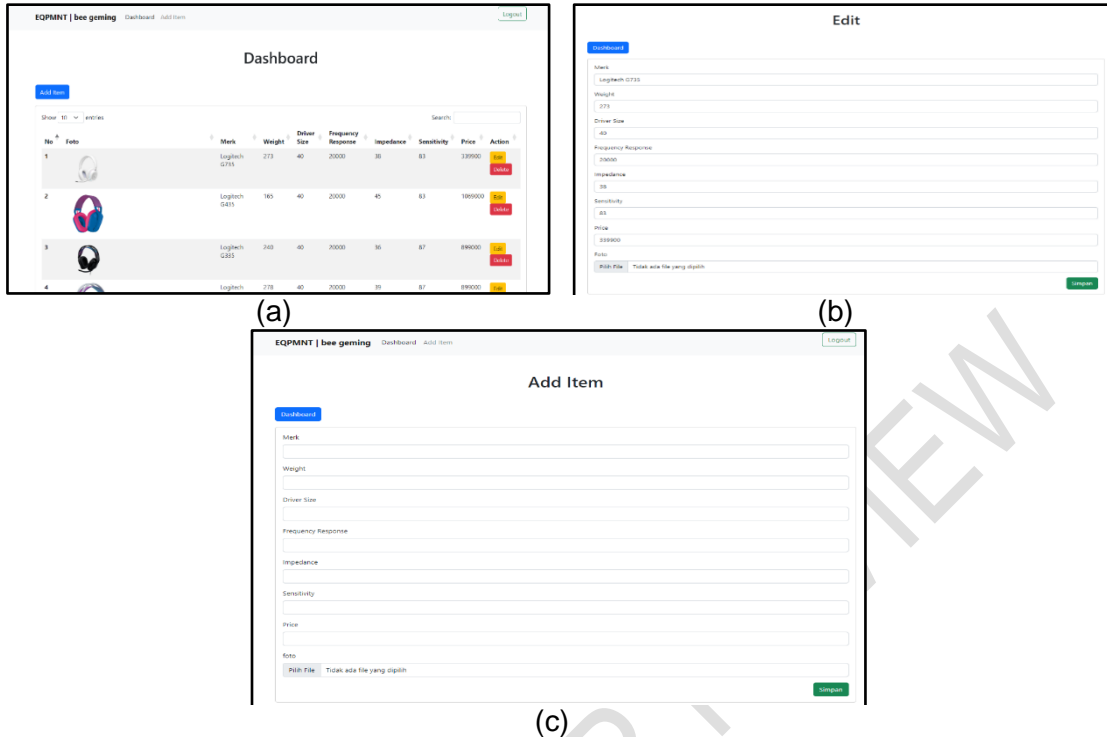

Figure 10 : Admin Dashboard Page, Edit Page and Add Item Page

Figure 10c is the result of the implementation of the add item page. On the page page, the admin can add items according to the list box available, after completing the data available, after completing filling in the data added to the item, there is a save button to save all new data added by the admin and stored in the database.

4.2. System Testing

Testing of this gaming headset recommendation system is divided into three parts parts, namely scenario tests, user satisfaction tests of the gaming headset recommendation system with the end user computing satisfaction (EUCS) method, and evaluation. gaming headset recommendation system with the end user computing satisfaction (EUCS) method, and evaluation.

This scenario test is carried out to validate the calculations produced by the system manually. The alternative gaming headset data used were 10 pieces in the calculation comparison. Table 1 is the selected gaming headset alternative data.

Table 1 : Alternative Data Table

No	Headset Gaming
1	Logitech Pro
2	Logitech G735
3	Arctis Nova 1 White
4	Arctis 5
5	HyperX Cloud II

- 6 Logitech G335
- 7 Arctis 3
- 8 HyperX CloudX
- 9 Razer Kraken V3
- 10 Sades Warden I

Table 2 is a decision matrix containing criteria values for gaming headsets. As in the table below, No means the number of gaming headsets selected for comparison calculation, then there are weight criteria, price criteria, driver size criteria, fr means frequency response criteria, impedance criteria, and sensitivity criteria. impedance, and sensitivity criteria. Criteria values are obtained through questionnaires that have been distributed to 28 respondents. Applying a Likert scale to be able to determine the criteria value of the gaming headset.

Table 2 : Decision Matrix Table

No	Weight	Price	Driver Size	Fr	Impedance	Sensitivity
1	259	1499000	50	20000	32	107
2	273	339900	40	20000	38	83
3	272	750000	40	22000	36	93
4	277	898878	40	22000	32	98
5	320	1496725	53	23000	30	98
6	240	899000	40	20000	36	87
7	295	1198500	40	22000	32	98
8	337	897975	53	25000	30	39
9	325	1496725	50	20000	32	96
10	330	1099000	50	20000	26	105

Next is to determine the weight value of user preferences for each criterion. Then in this calculation trial, user preferences were carried out using dummy data, where the weight of the weight criteria was very not important, the weight of the price criterion is very important, the weight of the driver size criterion is normal, fr criteria weight is not important, impedance criteria weight is normal, and sensitivity criteria weight is important. sensitivity is important.

$$W = \{[1,5,3,2,3,4]\} = 18 \quad (3)$$

In table 3 is the calculation of the weight of user criteria divided by the total criteria specified by the user. Then from the calculation results Then from the calculation results, if it is totaled, the result must be equal to one.

Table 3 : Criteria Weight Table

Criteria	Criteria Weight
K1	0.06
K2	0.28
K3	0.17

K4	0.11
K5	0.17
K6	0.22

Table 4 is a table for determining cost and benefit attributes. If the criterion attribute is cost, the value to be taken is the smallest value of the criterion, while the benefit criterion attribute is the largest value of the criteria in the trial data table.

Table 4 : Criteria Attribute Table

K1	K2	K3	K4	K5	K6
240	339900	40	20000	26	107

The next step is to normalize the decision matrix. This normalization process is carried out according to the type of criteria or formula that depends on the type of criteria in the table above. In this scenario test, the weight, price, driver size, frequency response and impedance criteria use the cost type, which is to find the minimum value of each alternative for each criterion and then divide by the value of the alternative and the criteria. Then for benefit type criteria, sensitivity is by dividing the value of the alternatives and criteria by the greatest or maximum value of the alternatives and criteria. criteria with the largest or maximum value of each alternative for each criterion. each criterion. The following is an example of normalization calculation on the first alternative.

$$weight = \frac{\min(259, 273, 272, 277, 320, 240, 295, 337, 325, 330)}{259} \quad (4)$$

$$= \frac{240}{259} = 0.927$$

$$driver\ size = \frac{\min(50, 40, 40, 40, 53, 40, 40, 53, 50, 50)}{50} = \frac{40}{50} = 0.8 \quad (5)$$

$$impedance = \frac{\min(32, 38, 36, 32, 30, 36, 32, 30, 32, 26)}{32} = \frac{26}{32} = 0.813 \quad (6)$$

$$sensitivity = \frac{107}{\max(107, 83, 93, 98, 98, 87, 98, 39, 96, 105)} = \frac{107}{107} = 1 \quad (7)$$

After doing the normalization calculation on alternative 1, then calculate the normalization until alternative 10, and the calculation results can be seen as a whole through table 5 below.

Table 5 : Decision Matrix Normalization Table

No	Weight	Price	Driver Size	Fr	Impedance	Sensitivity
1	0.927	0.226	0.8	1	0.813	1
2	0.879	1	1	1	0.684	0.776
3	0.882	0.453	1	0.909	0.722	93
4	0.866	0.378	1	0.909	0.813	98
5	0.75	0.227	0.754	0.87	0.867	98
6	1	0.378	1	1	0.722	87
7	0.814	0.283	1	0.9	0.813	98
8	0.712	0.378	0.754	0.8	0.867	39

9	0.738	0.227	0.8	1	0.813	96
10	0.727	0.309	0.8	1	1	105

The next step is the calculation of SAW by multiplying each criterion data with each criterion weight that has been obtained previously, after completing the calculation, to get the final score, it can be calculated by summing up all the criteria of the alternative. can be calculated by summing up all the criteria of the alternative. Table 6 is the SAW calculation and the final value of all alternative scenario tests.

Table 6 : Final Score Result Table

Merk	Calculation	Final Score
Logitech Pro	$(0.927 \times 0.06) + (0.226 \times 0.28) + (0.8 \times 0.17) + (1 \times 0.11) + (0.813 \times 0.17) + (1 \times 0.22)$	0.717
Logitech G735	$(0.879 \times 0.06) + (1 \times 0.28) + (1 \times 0.17) + (1 \times 0.11) + (0.684 \times 0.17) + (0.776 \times 0.22)$	0.891
Arctis Nova 1 White	$(0.882 \times 0.06) + (0.453 \times 0.28) + (1 \times 0.17) + (0.909 \times 0.11) + (0.722 \times 0.17) + (0.869 \times 0.22)$	0.756
Arctis 5	$(0.866 \times 0.06) + (0.378 \times 0.28) + (1 \times 0.17) + (0.909 \times 0.11) + (0.813 \times 0.17) + (0.916 \times 0.22)$	0.760
HyperX Cloud II	$(0.75 \times 0.06) + (0.227 \times 0.28) + (0.754 \times 0.17) + (0.87 \times 0.11) + (0.867 \times 0.17) + (0.916 \times 0.22)$	0.675
Logitech G335	$(1 \times 0.06) + (0.378 \times 0.28) + (1 \times 0.17) + (1 \times 0.11) + (0.722 \times 0.17) + (0.813 \times 0.22)$	0.739
Arctis 3	$(0.814 \times 0.06) + (0.283 \times 0.28) + (1 \times 0.17) + (0.909 \times 0.11) + (0.813 \times 0.17) + (0.916 \times 0.22)$	0.731
HyperX CloudX	$(0.712 \times 0.06) + (0.378 \times 0.28) + (0.754 \times 0.17) + (0.8 \times 0.11) + (0.867 \times 0.17) + (0.364 \times 0.22)$	0.585
Razer Kraken V3	$(0.738 \times 0.06) + (0.227 \times 0.28) + (0.8 \times 0.17) + (1 \times 0.11) + (0.813 \times 0.17) + (0.897 \times 0.22)$	0.683
Sades Warden I	$(0.727 \times 0.06) + (0.309 \times 0.28) + (0.8 \times 0.17) + (1 \times 0.11) + (1 \times 0.17) + (0.981 \times 0.22)$	0.755

The last step after calculating and getting the final value is to sort the final value from largest to smallest to find out what is the best alternative, and will be described in table 7.

Table 7 : RankingTable

Ranking	Headset Gaming	Final Score
1	Logitech G735	0.891
2	Arctis 5	0.760
3	Arctis Nova 1 White	0.756
4	Sades Warden I	0.755
5	Logitech G335	0.739
6	Arctis 3	0.731
7	Logitech Pro	0.717
8	Razer Kraken V3	0.683
9	HyperX Cloud II	0.675

1.1. User Satisfaction Test

The user testing process is carried out using the End User Computing Satisfaction (EUCS) model. The questionnaire that has been made and distributed gets as many as 28 respondents. 28 Respondents were obtained including 8 visitors to the edu computer store, and as many as 20 people from the author's closest friends. The questionnaire that was made filled in several questions that referred to 5 assessment components, namely content quality, accuracy, format, ease of use, and timeliness.

Table 8 : EUCS Question List Table

Question	Measurement	Question
P1	Content	Do you think the content of the information on this website matches your needs?
P2		Do you think the content of this website is clear and easy to understand?
P3	Accuracy	Do you think this website displays specific and accurate information?
P4		Do you think this website has displayed the right and correct page?
P5	Format	Do you think the menu structure of this website easy to understand?
P6		Do you think the appearance of the layout structure of this website makes it easy for users?
P7	Ease of Use	Do you think this website is easy to use to use?
P8		Do you think this website is easy to access from anywhere and anytime?
P9	Timeliness	Does this website save time in searching for the gaming headset needed by users?
P10		Does this website always display the latest information?

The next step is to calculate the percentage score using a Likert scale, which can be seen in table 9.

Table 9 : EUCS Questionnaire Table

Question	Answers				
	STS	TS	N	S	SS
Do you think the content of the information on this website matches your needs?	0	2	4	10	12
Do you think the content of this website is clear and easy to understand?	0	2	1	11	14
Do you think this website displays specific and accurate information?	0	3	7	8	10
Do you think this website has displayed the right and correct page?	0	1	6	6	15
Do you think the menu structure of this website easy to understand?	0	0	4	7	17

Do you think the appearance of the layout structure of this website makes it easy for users?	0	0	7	9	12
Do you think this website is easy to use to use?	0	1	6	8	13
Do you think this website is easy to access from anywhere and anytime?	0	3	6	6	13
Does this website save time in searching for the gaming headset needed by users?	0	0	4	8	16
Does this website always display the latest information?	0	3	10	5	10

The quality of the system can be measured on the content component through questions in P1 and P2. in question P1 there are 12 responses strongly agree, 10 responses agree, 4 neutral responses, and 2 disagree. agree, 10 responses agree, 4 neutral responses, and 2 disagree. Percentage calculation The calculation of the percentage score on the first question is as follows.

$$= \frac{(12 * 5) + (10 * 4) + (4 * 3) + (2 * 2) + (0 * 1)}{5 * 28} * 100\% \quad (8)$$

$$= 82,85\%$$

In question P2, there were 14 strongly agree responses, 11 agree responses, 1 neutral response, and 2 disagree responses. neutral, and 2 responses disagree. Calculation of the percentage score on the second question second question is as follows.

$$= \frac{(14 * 5) + (11 * 4) + (1 * 3) + (2 * 2) + (0 * 1)}{5 * 28} * 100\% \quad (9)$$

$$= 86,42\%$$

The final percentage on the content component can be calculated by averaging the two questions P1 and P2 as follows.

$$= \frac{(82,85 + 86,42)}{2} * 100\% = 84.63\% \quad (10)$$

The quality of the system can be measured on the accuracy component through questions in P3 and P4. in question P3 there were 10 responses strongly agreeing, 8 responses agreeing, 7 neutral responses, and 3 responses disagreeing. The calculation of the percentage score on the third question is as follows.

$$= \frac{(10 * 5) + (8 * 4) + (7 * 3) + (3 * 2) + (0 * 1)}{5 * 28} * 100\% \quad (11)$$

$$= 77,85\%$$

In question P4, there were 15 strongly agree responses, 6 agree responses, 6 neutral responses, and 1 disagree response, neutral, and 1 disagree response. Calculation of the percentage score on the fourth question fourth question is as follows.

$$= \frac{(15 * 5) + (6 * 4) + (6 * 3) + (1 * 2) + (0 * 1)}{5 * 28} * 100\% \quad (12)$$

$$= 85\%$$

The final percentage on the accuracy component can be calculated by calculating the average of the two questions P3 and P4 as follows.

$$= \frac{(77,85 + 85)}{2} = 81,42\% \quad (13)$$

The quality of the system can be measured on the form component (format) through questions in P5 and P6. in question P5 there were 17 responses strongly agree, 7 responses agree, 4 neutral responses. Calculation of the percentage score on the third question is as follows.

$$= \frac{(17 * 5) + (7 * 4) + (4 * 3) + (0 * 2) + (0 * 1)}{5 * 28} * 100\% \quad (14)$$

$$= 89,28\%$$

In question P6 there were 12 responses strongly agreed, 9 responses agreed, 7 responses were neutral. The calculation of the percentage score on the fourth question is as follows.

$$= \frac{(12 * 5) + (9 * 4) + (7 * 3) + (0 * 2) + (0 * 1)}{5 * 28} * 100\% \quad (15)$$

$$= 83,57\%$$

The final percentage on the format component can be calculated by calculating the average of both questions P5 and P6 as follows.

$$= \frac{(89,28 + 83,57)}{2} = 86,42\% \quad (16)$$

System quality can be measured in the ease of use component through questions in P7 and P8. in question P7 there were 13 responses strongly agreeing, 8 responses agreeing, 6 neutral responses, and 1 response disagreeing. The calculation of the percentage score on the third question is as follows.

$$= \frac{(13 * 5) + (8 * 4) + (6 * 3) + (1 * 2) + (0 * 1)}{5 * 28} * 100\% \quad (17)$$

$$= 83,57\%$$

In question P8 there were 13 responses strongly agreed, 6 responses agreed, 6 responses were neutral, and 3 responses disagreed. neutral, and 3 responses disagree. Calculation of the percentage score on the fourth question fourth question is as follows.

$$= \frac{(13 * 5) + (6 * 4) + (6 * 3) + (3 * 2) + (0 * 1)}{5 * 28} * 100\% \quad (18)$$

$$= 80,71\%$$

The final percentage on the ease of use component can be calculated by calculating the average of the two questions P7 and P8. by calculating the average of the two questions P7 and P8 as follows.

$$= \frac{(83,57 + 80,71)}{2} = 82,14\% \quad (19)$$

System quality can be measured in the timeliness component through questions in P9 and P10. through the questions in P9 and P10. in question P9 there were 16 responses strongly agreeing, 8 responses agreeing, and 4 neutral responses. The calculation of the percentage score on the third question is as follows.

$$= \frac{(16 * 5) + (8 * 4) + (4 * 3) + (0 * 2) + (0 * 1)}{5 * 28} * 100\% \quad (20)$$

$$= 88,57\%$$

In question P10 there were 10 responses strongly agreeing, 5 responses agreeing, 10 responses neutral, and 3 responses disagreeing. neutral, and 3 responses disagree. Calculation of the percentage score on the fourth question fourth question is as follows.

$$= \frac{(10 * 5) + (5 * 4) + (10 * 3) + (3 * 2) + (0 * 1)}{5 * 28} * 100\% \quad (21)$$

$$= 75,71\%$$

The final percentage on the timeliness component can be calculated by averaging the two questions P9 and P10 as follows.

$$= \frac{(88,57 + 75,71)}{2} = 82,14\% \quad (22)$$

After calculating each component, the percentage of the final score was calculated. The percentage calculation is done by finding the average value of each component. The calculation is as follows

$$= \frac{(84,63 + 81,42 + 86,42 + 82,14 + 82,14)}{5} = 83,35\% \quad (23)$$

The successful completion of the construction of the gaming headset recommendation system using the simple additive weighting (SAW) approach was based on the results of the previous scenario test. This ensured that the calculation results obtained using any manual methodology were consistent.

The format portion achieved the highest score, obtaining a value of 86.42%. Conversely, the accuracy section had the lowest value, with a score of 81.42%. The user happiness level of the gaming headset suggestion system is determined to be 83.35%. This value indicates a strong agreement between the users and the system, as determined through testing the level of user satisfaction.

4. CONCLUSION

The successful development and implementation of a recommendation system for gaming headsets has been achieved through the utilization of the basic additive weighting method. The system possesses a capability to provide recommendations for gaming headsets by doing comparisons across six distinct factors, namely weight, price, driver size, frequency response, impedance, and sensitivity, in accordance with user preferences. The present system has been developed utilizing the Laravel PHP framework on a web-based platform.

This system has undergone two trials, specifically scenario testing and user satisfaction trials. Experimental trials are conducted to demonstrate the alignment between the

computations performed by the system and those conducted manually. In order to ascertain the effectiveness of system development, a user happiness test is conducted by the distribution of questionnaires and the posing of inquiries that pertain to the End-User Computing happiness (EUCS) testing methodology to a sample of 28 respondents. Based on the findings derived from the administered questionnaire, the ultimate percentage outcome is at 83.35%. Consequently, it can be inferred that the respondents exhibit a significant inclination towards endorsing the gaming headset recommendation system.

REFERENCES

1. J. W. Kelly, L. A. Cherep, A. F. Lim, T. Doty, and S. B. Gilber, "Who are virtual reality headset owners? A survey and comparison of headset owners and non-owners," *Proceedings - 2021 IEEE Conference on Virtual Reality and 3D User Interfaces, VR 2021*, pp. 687–694, 2021, doi: 10.1109/VR50410.2021.00095.
2. A. M. Aizenman, G. A. Koulieris, A. Gibaldi, V. Sehgal, D. M. Levi, and M. S. Banks, "The Statistics of Eye Movements and Binocular Disparities during VR Gaming: Implications for Headset Design," *ACM Transactions on Graphics*, vol. 42, no. 1, 2023, doi: 10.1145/3549529.
3. M. Froehlich and S. Azhar, "Investigating virtual reality headset applications in construction," *52nd Associated Schools of Construction Annual International Conference*, pp. 13–16, 2016, [Online]. Available: <http://ascpro0.ascweb.org/archives/cd/2016/paper/CPRT195002016.pdf>
4. T. A. Garner, "Game Sound from Behind the Sofa: An Exploration into the Fear Potential of Sound & Psychophysiological Approaches to Audio-centric , Adaptive Gameplay," 2013, [Online]. Available: <http://forskningbasen.deff.dk/Share.external?sp=Sa691dc47-edf7-47d1-9f41-841003cbb7ff&sp=Saau>
5. P. E. Ngs *et al.*, "Audio Mostly," in *Proceedings of the Audio Mostly Conference*, 2008, p. 137.
6. T. A. Garner and M. N. Grimshaw, "A psychophysiological assessment of fear experience in response to sound during computer video gameplay," *Proceedings of the IADIS International Conferences - Interfaces and Human Computer Interaction 2013, IHCI 2013 and Game and Entertainment Technologies 2013, GET 2013*, pp. 45–53, 2013.
7. E. Omar, "Active Noise Cancellation: The Unwanted Signal and the Hybrid Solution," *Adaptive Filtering Applications*, 2011, doi: 10.5772/16844.
8. T. R. Bourk, "Noise cancellation headset," *The Journal of the Acoustical Society of America*, vol. 94, no. 1, pp. 617–618, 1993, doi: 10.1121/1.406993.
9. S. Liebich, J. Fabry, P. Jax, and P. Vary, "Signal processing challenges for active noise cancellation headphones," *Speech Communication - 13th ITG-Fachtagung Sprachkommunikation*, pp. 11–15, 2020.
10. A. Y. C. Tang, M. A. Mahmoud, and M. Othman, "The Application of Decision Support System by Using Fuzzy SAW Method in Determining the Feasibility of Electrical Installations in Customer's House Open Normative Multi-agent Communities View project A STREAMING PROFILER FOR MATCHING ENTRY-LEVEL STUDENTS WITH ACADEMIC PROGRAMS View project Andino Maselena," *Article in International Journal of Pure and Applied Mathematics*, vol. 119, no. 16, pp. 4277–4286, 2018, [Online]. Available: <http://www.acadpubl.eu/hub/>
11. C. FANNY and W. ISTIONO, "Analysis Timeline User Content on Instagram Using Simple Additive Weighting Algorithm," *Journal of Applied Computer Science & Mathematics*, vol. 16, no. 1, pp. 14–17, 2022, doi: 10.4316/jacsm.202201002.
12. N. Vafaei, R. A. Ribeiro, and L. M. Camarinha-Matos, "Assessing Normalization

- Techniques for Simple Additive Weighting Method,” *Procedia Computer Science*, vol. 199, pp. 1229–1236, 2021, doi: 10.1016/j.procs.2022.01.156.
13. N. Dobrovolskienė and A. Pozniak, “Simple Additive Weighting versus Technique for Order Preference by Similarity to an Ideal Solution: which method is better suited for assessing the sustainability of a real estate project,” *Entrepreneurship and Sustainability Issues*, vol. 8, no. 4, pp. 180–196, 2021, doi: 10.9770/jesi.2021.8.4(10).
 14. D. Wira Trise Putra and A. Agustian Punggara, “Comparison Analysis of Simple Additive Weighting (SAW) and Weighed Product (WP) in Decision Support Systems,” *MATEC Web of Conferences*, vol. 215, pp. 1–5, 2018, doi: 10.1051/mateconf/201821501003.
 15. A. Afshari, M. Mojahed, and R. Yusuff, “Simple additive weighting approach to personnel selection problem,” *International Journal of Innovation, Management and Technology*, vol. 1, no. 5, pp. 511–515, 2010, [Online]. Available: http://www.researchgate.net/publication/256031272_Simple_Additive_Weighting_Approach_to_Personnel_Selection_Problem/file/e0b49524c34debf7b5.pdf
 16. S. Putra and W. Istiono, “Implementation Simple Additive Weighting in Procedural Content Generation Strategy Game,” *International Journal of Multidisciplinary Research and Publications (IJMRAP)*, vol. 4, no. 12, pp. 9–18, 2022, [Online]. Available: <https://ijmrapp.com/volume-4-issue-12/>
 17. R. Simanaviciene and L. Ustinovichius, “Sensitivity analysis for multiple criteria decision making methods: TOPSIS and SAW,” *Procedia - Social and Behavioral Sciences*, vol. 2, no. 6, pp. 7743–7744, 2010, doi: 10.1016/j.sbspro.2010.05.207.
 18. S. Wijayanto, D. Napitupulu, K. Adiyarta, and A. P. Windarto, “Decision Support System of New Student Admission Using Analytical Hierarchy Process and Simple Additive Weighting Methods,” *Journal of Physics: Conference Series*, vol. 1255, no. 1, 2019, doi: 10.1088/1742-6596/1255/1/012054.
 19. B. S. Sinaga and F. Riandari, “Implementation of Decision Support System for Determination of Employee Contract Extension Method Using SAW,” *Journal Of Computer Networks, Architecture and High Performance Computing*, vol. 2, no. 2, pp. 183–186, 2020, doi: 10.47709/cnacc.v2i2.397.