

Original Research Article

Effects of cyclone dimensions on quality of syngas produced with a wood-fired biomass gasifier

Name of author and affiliation

Formatted: Indent: Left: 1.5", First line: 0.5"

ABSTRACT

Charcoal gasification was widely used during the second World War to deal with petroleum scarcity. When petroleum was again available after the war, gasification was neglected afterwards [1]. However, fossil resources are nowadays known as non-renewable and there are several researches carried out all over the world to develop renewable sources of energy. Under that scope gasifiers are of great interest in the developing countries for developing individual or decentralised sources of energy. Even in developed countries, development of gasification projects is in progress.

In a previous work, we designed and fabricated a downdraft biomass gasifier with a relatively big cyclone and filtration units. Produced syngas was full of moisture and carbon dioxide (CO₂) when the gasifier was fed with wood, but moisture content was lesser with charcoal. However in a Sahelian country as Burkina Faso with limited wood resources, traditional production of charcoal from high density wood exhibits low conversion efficiency. Therefore further work should be done to use low density wood itself from agricultural, furniture makers or sawmill wastes. This paper addresses the design, fabrication and testing of a smaller cyclone separator unit to replace the first one formerly fabricated. We obtained less moisture content, almost no carbon dioxide in the produced syngas and better combustion from wood waste of the same initial humidity content.

Comment [NO11]: Not important information in Abstract

Keywords : Gasifier, Syngas, Wood, Moisture, Cyclone, Design

1. INTRODUCTION

In Burkina Faso, the total consumption of primary energy was estimated equal to nearly 2625 Kilotonnes in 2008 with a strong dependence on biomass which represents more than 80% of consumed energy [2], [3]. On year 2019, total consumption of primary energy raised to 4657 Kilotonnes with 99% from biomass whereas hydropower and solar photovoltaic represents less than 1% [4].

Biomass gasification, very little used in Burkina Faso, is one of the most efficient methods for converting biomass into thermal and electrical energy. Despite the abundance of waste of agricultural, vegetable and household origin, the large-scale exploitation of this conversion process is very little developed in Burkina Faso. In a bibliographic review made in 2014, it was established that gasification of waste may be an interesting alternative for Burkina Faso [5]. Barry et al. [6] stated that: "The syngas production sector by gasification of mobilizable residues can only be competitive with the butane gas market if the technology is manufactured locally." In fact gasification units were installed at Dano, Po and Bama in Burkina Faso. But these projects didn't fully succeed, even if they had gasification units technologies that are in production elsewhere in the world. However gasification still appears as feasible in Burkina Faso, provided some economical and technical considerations be taken in account [7]. Therefore, we have a challenge to locally manufacture gasification units for electrical power generation in Burkina Faso.

Comment [NO12]: Please add more information about the existing research in this field.

With these considerations in mind, we are in the process of designing and thoroughly testing small-scale gasifiers in order to better master the gasification technology with locally manufactured units. We have previously designed and fabricated a laboratory-scale gasifier with the aim of converting biomass, mainly waste from the city of Koudougou, into a gas that can be used as fuel. This paper report worked to improving the first syngas purification stage of that gasifier.

Comment [NO13]: You not doing this research because you thing in your mind. You must put the scientific reason as strong justification.

2. MATERIALS AND PROCESS PREPARATION

2.1 Materials

Components of the gasification unit are essentially grouped into two parts namely the reactor body and the auxiliary equipments. The cyclone separator, part of the auxiliary equipments constitute the subject of this work. [Describe your feedstock use in chamber](#)

Comment [NO14]: Materials should be your feedstock detail description

2.2 Component of gasifier

2.1.1 Syngas generator

2.2.1 Generator

The gasifier used here (or in this case) is a co-current down draft type fuelled with wood. The body of the gas generator (or the reactor) is made up of two parts : an upper part which includes the hopper and the combustion chamber, and a lower part consisting of the gas outlet pipe, the ignition and cleaning ports.

2.2.2 Auxiliary equipments

The auxiliary equipments mainly comprise a cyclone, a gas expansion chamber, a filter and an air blower.

a) The cyclone

At the outlet of the reactor, the synthesis gas contains particles in suspension and water vapour. Several authors have used a cyclone separator as a first syngas purification stage [8], [9] and [10].

The separator used in our gasification process are cyclones constructed with dimensions given in table 1 below. In the first fabrication, the synthesis gas produced in the reaction chamber was input in the cyclone through a 6cm diameter pipe. In the second fabrication, diameter of the admission pipe to the cyclone was reduced to 4cm.

Both two cyclones helped us eliminate of heavy particles (tar) and partial condensation of water vapor contained in the synthesis gases.

Comment [NO15]: Put the drawing and schematic diagram of your system.

b) The burner

Through a tube, the gases are channeled to the generating set for its operation. Before injecting the syngas into the engine's combustion chamber, a pilot burner is built to ensure that the syngas is combustible. The first burner we constructed was simply fabricated with empty camping gas cannes as illustrated in figure 1. below.

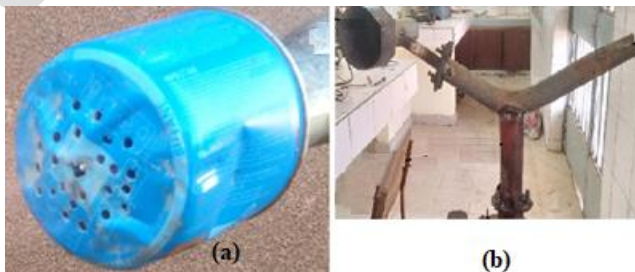

Figure 1 : Test burners used up front the internal combustion engine

Comment [NO16]: Put the complete system with label

Later, we built another burner using the “ventury effect” as illustrated on figure 1.b above.

2.1.3 Expérimental setup 4.0 EXPERIMENTAL SET UP

Parts of the biomassgasifier, namely: the reactor, the cyclone, the gas expansion chamber, the filter and the burner are thenassembled by screws and nuts. This setup allows to separatedifferents parts of the gasifierduring maintenance. Figure 2 belowillustrates the experimental setup wecreatedduringthiswork. This gasification unit, made according to the Imbert model is a “downdraftgasifier ”.



Comment [NO17]: Label on your figure

Figure 2 : Experimental setupwith first and second cyclone

Formatted: Normal, Line spacing: single

2.32-2-Process 3.0 DESIGN MODELLING OF THE GASIFIER

Comment [NO18]: Move as 3.0

Gasificationis a process thatwaswidelyusedduring the Second World War to deal with the shortage of hydrocarbons.Nowadays, in the face of climate change and the lack of oilresources, the urgent need for this process, abandonedafterseveralyears, isresurfacing. From an energy point of view, the termbiomassrefers to all organicmatterthatcan beused as energy sources [11], [12].Thus, the existence of a high variability in the composition of biomasspromotes the development ofvarious technologies for itsenergyrecovery[13].Gasificationis a thermal conversion process of carbonaceous or organicmaterials in the presence of an oxidizing agent (oxygen, carbondioxide, water vapour) into a synthesisgas.In otherwords, gasificationis the process of convertingbiomassinto a mixture of combustible gases by partial oxidation atvery high temperatures [14], [15].

3. METHODS

At the reactoroutlet, syngas contains combustible gases, water vapor, and solidparticles (tar, ashresidue). It isadvised to purifysyngasbeforeusingit in an ICE (Internal Combustion Engine) for electrical power generation. Purification methodsinclude separation, filteringamongmanyothers.

3.1 Assembly of newcyclone

3.1.1 Cyclone

Cyclones have been usedsince the late 1800's to removedustfromindustrialgasstreams. Their simple design, low capital and maintenance costs, and adaptability to a wide range of operating conditions have made cyclones the mostwidelyusedindustrialdust collectors [16].

The first cyclone webuilt [17] haveproved to bepoorly effective, hence the need for itsimprovement.

In a cyclone, the gases arrive tangentially to the body of it. Heavy particles are retained by the cyclone and settle to the bottom while light ones rise and emerge vertically.

Cyclone collection efficiency, η , is defined as the fraction of particles of a given size that is retained by the cyclone. Several theories have been developed to predict collection efficiency. Unfortunately, these greatly differ in complexity. While a general agreement seems to be that operating parameters of the system should be used to predict performance, there is less agreement on the effects of cyclone dimensions and geometry [18].

According to Leith et al. [19] has identified three general approaches to predicting cyclone collection efficiency. We will only consider one of these: the Critical Diameter.

This method assumes that particles enter the cyclone at certain radial distance from the cyclone axis. Particles must travel outward from this position to the wall to be collected; the critical particle is the size that travels exactly this distance during its residence time in the cyclone. Different assumptions about initial radial position and residence time lead to different approximate solutions.

The According to Lapple et al. [20] cut diameter theory is the most widely used example, also called « the time flight approach ». Lapple assumed that dust entering the cyclone was evenly distributed across the inlet opening. The particle size that travels from the inlet halfwidth to the wall during the time in the cyclone is collected with 50% efficiency is called the cut diameter. Lapple calculated this particle size, the cut diameter, as:

$$d_{50} = \sqrt{\frac{9\mu b}{2\pi\rho_p v_i N}}$$

With

- μ : gas viscosity (Pa.s)
- b : cyclone inlet width (m)
- ρ_p : particle density (kg/m^3)
- v_i : gas inlet velocity (m/s)
- N : number of revolutions gas makes in the cyclone (dimensionless)

The "static particle" theory of Barth [19] to predict d_{50} gives:

$$d_{50} = \sqrt{\frac{9\mu Q}{\pi\rho_p Z_c V_{tmax}^2}}$$

Where:

- μ : gas viscosity
- Q : gas flow
- ρ_p : particle density
- Z_c : vortex core length
- V_{tmax} : maximum tangential velocity

Tangential velocity of particles and gas are assumed equal.

Lozia and Leith [21] developed equations to predict these terms from measurements of the gas flow pattern within cyclones of various dimensions and found that maximum tangential velocity is given [22] by expression:

$$V_{tmax} = 6.1 V_i \left(\frac{ab}{D^2}\right)^{0.61} \left(\frac{D}{D_e}\right)^{0.74} \left(\frac{D}{H}\right)^{0.33}$$

Core length was determined [47] with two dimensional assumptions [17]:

$$z_c = H - S \quad \text{when } d_c < B$$

Comment [NO19]: Gaz = gas?

$$z_c = (H - S) - \left(\frac{H-h}{\left(\frac{D}{B}\right)^{-1}} \right) \left(\frac{\frac{D}{B}-1}{\frac{d_c}{B}-1} \right) \quad \text{when } d_c > B$$

Core diameter is given [17] by expression :

$$d_c = 0.47D \left(\frac{ab}{D^2} \right)^{-0.26} \left(\frac{D_e}{D} \right)^{1/4}$$

Geometrical dimensions are depicted in figure 3 from Loza and Leith [21] below :

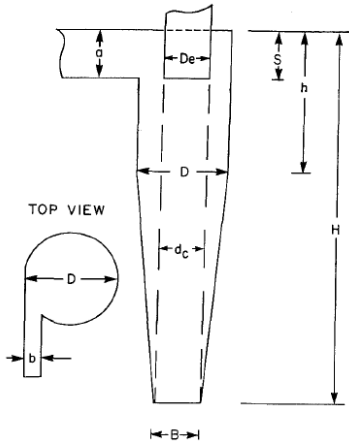

Figure 3 : Cyclone parameter according to Donna Lee Loza & David Leith [21]

For a given syngas reactor, if we let the gas flow Q , particles density and gas viscosity all constants, we could group their values in one constant cte and see that collection efficiency could be expressed as :

$$d_{50} = \frac{cte}{V_{tmax} \sqrt{z_c}}$$

This formula can be compared to that of given by Matsen [23] :

$$d_{50}^0 = 1.16 \sqrt{\frac{\mu W D}{\rho U^2 t}}$$

where

μ = gas viscosity

W = cyclone inlet width

D = cyclone barrel diameter

ρ = particles density

U = gas velocity at inlet

t = average gas residence time

Gas residence time is given by :

$$t = \frac{V}{h W U} \square,$$

where

V = cyclone volume

h = cyclone inlet height

These three formula suggested us that the bigger V_{tmax} , the lesser cut diameter, hopefully better particles removal.

Because for a given partial pressure in the reactor, particles exit from the reactor should be higher when the exit surface, ie the pipe diameter decrease.

Considering the relative cost calculated by Stermand [24] as depicted in figure 4 below, we definitely opted for a smaller cyclone compared to the first one we built.

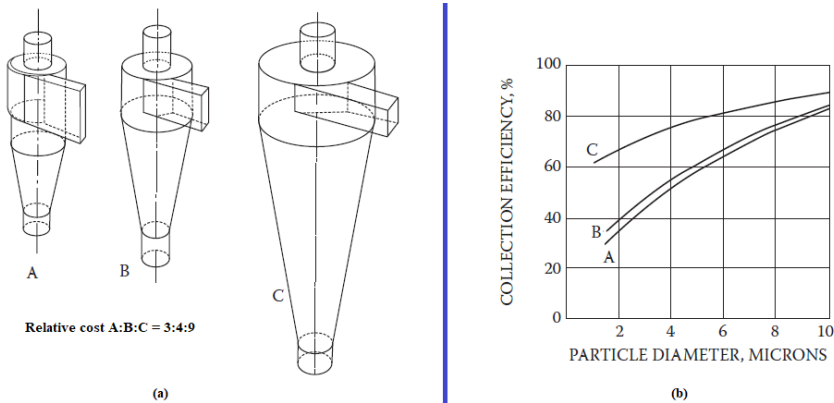

Figure 4 : Geometrical dimensions, relative cost and efficiency. Adapted from Iloza & Leith [21] and Stermand [22]

3.1.2 Manufacturing of the second cyclone

The cyclone we used is constructed using 2mm thick sheet metal. Dimensions are given in table 1 below :

Table 1 : Compared dimensions of the two cyclones

Item	Hauteur (cm)		Radius (cm)		Volume (cm ³)		Volume (L)	
	1 st	2 nd	1 st	2 nd	1 st	2 nd	1 st	2 nd
Higher cylinder	20	19.5	R=12	R = 7	9043.2	3000.07	9.43	3.00
Cone	60	20	R _{sup} = 12 ; R _{inf} = 6	R _{sup} = 7 ; R _{inf} = 5	8860.49	1539.13	9.05	
Lower cylinder	16	10	R = 6	R = 5	1808.64	875	1.81	0.86
Condensate cone	10	13	R _{sup} = 6 R _{inf} = 3	R _{sup} = 5 R _{inf} = 1.5	234.43	263.76	0.234	0.264
Total			Not applicable	Not applicable	19946.8	3621.53	19.95	3.26

The construction steps are as follows:

1. Cut the sheet and then bend it to form a cylinder with a radius of 12cm and a height of 20cm
2. We close the upper part of the cylinder then we perforate it.
3. We introduce and weld tangentially and vertically two tubes of 4cm in diameter in the two holes
4. We build another cylinder with a radius of 3cm and a height of 10cm. This cylinder is terminated by a cone of height 10cm and radius R₁ = 3cm; R₂ = 1.5cm. A condensed water and particle evacuation valve is screwed to the end of this unit.
5. We properly weld the different elements constructed previously.
6. Airtightness is always checked during assembly.

The finished second cyclone is shown at the right of the first one in figure 5 below :



Figure 5 : Comparison of the two cyclones separators

3.2 Power on and testing of the gasifier

3.2.1 Power on procedure

For the very first launch of the gasifier, we added charcoal to the grate located under the combustion port. Then we fill the combustion tube with coal to a height of 4 inches above the grate. Additionally, we need to fill the fuel hopper with air-dried wood and then follow the following instructions:

1. Sensors for measuring parameters such as temperature, humidity and gas analyzers are placed during the assembly of the experimental device to monitor the evolution of these parameters during the operation of the reactor
2. After checking the tightness of the experimental device, we adapt the blower then turn it on full blast for a few minutes to evacuate the gases in the different units.
3. In addition, fire is introduced from the ignition tube to initiate combustion. Diesel fuel can be used to initiate combustion. Using a cap, close the ignition tube by reducing the speed of the blower a little and then let it run. A few minutes later, we increase the speed by following the evolution of the temperatures.
4. As soon as combustion has started, we monitor, using the analyzers, the evolution of the proportions of combustible gases such as CO; CH₄ and H₂. When the CO proportion reaches 1060 ppm (part per million), let's test if the gases are combustible by approaching a flame.
5. We always check the permanence of combustible gases at the outlet of the reactor before using it in the engine. To do this, the speed of the blower must be adjusted so as to have a permanent production of combustible gas.

3.2.2 Power on and running the gasifier

After switching on the gasifier, the blower speeds must be adapted in order to keep the syngas production rate stable. Next, we need to refill the hopper before it is completely empty. Finally, we shake the grid regularly to make the ashes fall. To turn off the gasifier, the hopper must be closed so as to avoid any entry of air which could be used to maintain combustion.

3.2.3 Maintenance procedures

During operation of the gasifier we must regularly check the junctions and tightening to avoid any gas leaks. In addition, we must remove the ashes from the cleaning module every day after shaking the grid for a few minutes. We also open the filter and cyclone evacuation valve to remove the condensed liquid before restarting the gasification. Maintenance carried out every week following the following procedure:

1. Clean the bottom of the gasification unit, the fuel hopper, and the filter.

Comment [NO110]: Merge with experimental setup

2. Rinse the pipes and connections connecting the different components of the gasifier.
3. Replace the wood chips in the filter. Used shavings can be placed in the hopper and used as fuel.
4. Use high temperature silicone gasket to seal all pipes and the relatively to ambient air

Comment [NO111]: Merge experiment setup

4. RESULTS AND DISCUSSION

Cyclones are one of the cheaper and simpler dust collectors available, but they have a relatively low efficiency unless used with coarse dust [23]. By reducing the diameter of the inlet tube in the second cyclone, we hoped to have a greater gas entry speed into the cyclone. By reducing its volume, you have reduced the residence time in the cyclone. The total volume of the cyclone was brought down from 19.9 L to 3.26 L. This work is mainly qualitative due to technical limitations. We wanted to achieve better syngas quality at the exit of the purification units in terms of the combustion flame quality. Due to leak of well working gas analysers, results are only qualitatively appreciated. [Please add your table of experiment testing sampling.](#)

4.1 Testing with the first cyclone

4.1.1 Preliminary testing experiments Initial testing

~~The first test of the gasification unit we built was carried out on June 19, 2022 at the Physics laboratory of Norbert ZONGO University.~~ Paper and cardboard were used to operate the gasifier. During this test, we noticed the release of white smoke and a flow of black liquid at the leaky joints. During the experiment, we find that the gases produced are very poor in fuels (carbon monoxide, methane, dihydrogen, etc.). Produced syngas was flammable, but its combustion was barely steady.

4.1.2 Testing with wood as fuel with first cyclone Initial testing Using Wood

~~After the first preliminary test of the device, we made several adaptations.~~ The reactor which was of the stratified downdraft type was modified to a non-stratified gasifier. Then a cyclone was built to remove dust from the syngas. A blower is also suitable for injecting air directly into the reaction chamber. On Sunday October 16, 2022 in the physics laboratory, we used damp wood for the first time to operate the device after several adaptations of the reactor. During these experiments, we obtained a yellow flame as evidenced in figure 6 below and the formation of a very large quantity of water mixed with condensable liquid in the cyclone and in the filtration unit.



(a): Charcoal with first cyclone

(b) Wood with first cyclone

Figure 6 : Syngas combustion with first cyclone with charcoal and wood as combustible

At the end of the reaction, we observed a deposit of tar in the pipes as shown on figure 7.c. Additionally, the wood chips in the filtration unit became wet (d). Figures 7 illustrate the state of the wood chips after gasification (d), the water vapor condensed in the first (a) and that in the second cyclone (b). We see that there is much more water with the first cyclone than with the second one.

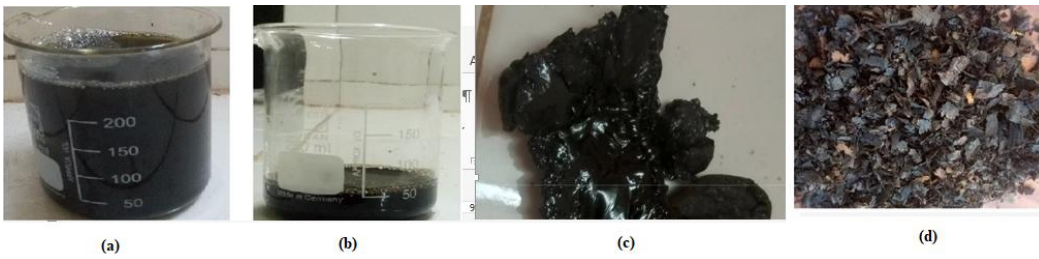

Figure 7 : Byproducts of the gasification process

4.1.3 [Additional Testing Testing with wood as fuel with the second cyclone](#)

After we replaced the cyclone separator, we followed the same experimental protocol as with the first cyclone in order to compare the quality of syngas. Figure 8 below illustrates the color of the flame with the second cyclone, respectively with charcoal and wood.

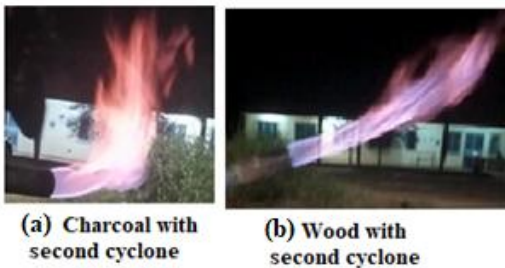

Figure 8 : Combustion flame quality with the second cyclone separator

4.2 Syngas composition evolution over time

During our various tests, we introduced temperature sensors above and at the outlet of the reactor to monitor the evolution of the temperature in the reactor and that of the syngas as they exit the reactor. Humidity sensors were also introduced to monitor the evolution of the humidity of the syngas at the outlet of the different units of the experimental device. Furthermore, gas analyzers, such as the Bacharach "Monoxor III", Bacharach "Fyrite INTECH 110" and a "Testo 325" are used to monitor the evolution of carbon monoxide, methane, dioxygen and temperature.

The results obtained after the various tests show that the syngas at the outlet of the device are made up of carbon monoxide (CO) and other combustible gases such as methane (CH₄) and dihydrogen (H₂).

With wood as fuel, the maximum quantity of CO measured is estimated at 2200 ppm on the other hand, with charcoal, this value can go up to 2300 ppm.

- a) When we used wood chips with the first cyclone :
 - the gases obtained were poorly flammable, nearly non-combustible,
 - syngas obtained was of white color like smoke,
 - gas analyzers showed high moisture and CO₂ content in the produced syngas,
 - only charcoal produced flammable gases with the first cyclone as evidenced in figures 6 above.
- b) When we used wood chips with the second cyclone with wood fuel of nearly initial moisture content:
 - The gases obtained were flammable

- Syngas obtained was almost transparent
- Gas analysis showed low moisture content and almost no CO₂ in the produced syngas
- No more need to use charcoal as fuel with the second cyclone as evidenced in figure 7 above.

On the other hand, we obtain combustible gases with a flame of the same color as that of wood if we make a mixture of wood and wood chips.

5. CONCLUSION

This work is part of a larger project with the main objective of designing and creating a gasifier powered by biomass from the town of Koudougou. This paper addressed the design, fabrication and testing of a second separator cyclone. In the first fabrication, the synthesis gas produced in the reaction chamber was admitted in the cyclone through a 6cm diameter pipe. In the second fabrication, diameter of the admission pipe to the cyclone was reduced to 4cm. This enabled us to divide the volume of the cyclone by 5.5 and resulted in better syngas quality evidenced by the combustion flame color and extent. [Conclusion must answer your objective effect of cyclone can increase/decrease the quality of syngas by reducing the gas emission of ???](#)

REFERENCES

- [1] T. B Reed and A Das, Handbook of Biomass Downdraft Gasifier Engine Systems, Solar Energy Research Institute, pp, 1950. <https://www.nrel.gov/docs/legosti/old/3022.pdf>, accessed 06 January 2023
- [2] Ministry of Energy in Burkina Faso, Energy Strategy 2019-2023; Report, 58 pages, 2018. French
- [3] Dabat M.H, Hanff E, Blin J. Biofuels, an opportunity to reduce poverty in Burkina Faso, 3rd days of research in social sciences. 15 pages, 2009. French
- [4] Energy policies component of the IFDD Access to Sustainable Energy program, Key figures on energy in Burkina Faso and in the UEMOA area, 2019 Report. French.
- [5] Nzihou Jean Fidele, Kouliadiati Jean, Segda B. Gérard. Potential and Feasibility of Solid Municipal Waste Treatment with Gasifiers in a Developing Country: A Review for Burkina Faso British Journal of Applied Science & Technology 4(3): 450-464, 2014 SCIENCE DOMAIN international www.sciencedomain.org
- [6] Fanta BARRY. "Evaluation of the conditions for developing an agricultural biomass gasification sector in Burkina Faso". PhD dissertation (French). International Institute of Water and Environmental Engineering Burkina Faso and University of Liège/Gembloux Agro-Bio Tech, Ouagadougou and Gembloux, Belgium. 200 pages, 2023. French
- [7] Ahmed L. S, Characterization of the performance of a pilot biomass gasification unit, technical, economic and environmental feasibility analysis for use by an artisan in an agri-food sector in Burkina Faso; Memory ; 2iE, P: 65 pages, 2013. French

- [8] RAKOTOMALALA R. M., design and production of a downdraftgasifier for domesticuse: Application to the gasification of eucalyptus chips, Memory, Ecole supérieure polytechnique d'Antananarivo, 104 pages. 2014 English
- [9] H. LaFontaine, G. P. Zimmerman, Construction of a simplifiedwoodgasgenerator for fuelinginternal combustion, Engines in a Petroleum Emergency; Report ; Washington, D.C.20472, Federal Emergency Management Agency, 66 pages, 1989
- [10] P. E. Akhator¹, A. I. Obanor² and E. G. Sadjere, Design and development of a small-scalebiomassdowndraftgasifier, Nigerian Journal of Technology (NIJOTECH) Vol. 38, No. 4, October 2019, pp. 922 – 930 PrintISSN: 0331-8443, Electronic ISSN: 2467-8821 <http://dx.doi.org/10.4314/njt.v38i4.15>
- [11] Georgio B, Gasification of biomass:removal of tars by washing, experimentalstudy and modeling, Doctoral thesis, University of Lyon. 196 pages, 2012. French
- [12] Rabarinjatovo H, Studies to improve the energy performance of a charcoalgasifierusing a fireplace; Memory ; University of Antananarivo, Ecole Supérieure Polytechnique; 65 pages, 2014. French
- [13] Basu P, BiomassGasification and Pyrolysis, Practical Design and Theory, pp. 8-20; 67-78, 2010.
- [14] Ajmal Latif M., A study of the design of fluidizedbedreactors for biomassgasification, PgDthesis, London University. 215 pages, 1999.
- [15] Solomatnikova O. et al, Profile of forestproducts, Bioenergytechnologybased on forestbiomass; Report, 168 pages, 2011. French
- [16] John Dirgo& David Leith (1985) Cyclone Collection Efficiency:Comparison of ExperimentalResultswithTheoreticalPredictions, Aerosol Science and Technology, 4:4, 401-415, DOI: 10.1080/02786828508959066
- [17] Nzihou Jean Fidele, Hamidou Salou, Imbga Kossi, Segda Bila Gerard, Ouattara Frederic, Tiemtore Hamadou. Electrical Power GenerationFrom Heat Recovered at the Throat of a DowndraftBiomassGasifier. American Journal of Science, Engineering and Technology. Flight. 8, No. 3, 2023, pp. 133-140. doi:10.11648/j.ajset.20230803.12
- [18] Leith, D. In Handbook of Environmental Engineering (N. C. Pereira an L. K. Wang, ed.). HumanaPress, Clifton, NJ, Vol I, p. 61, 1979
- [19] Lapple, C. E. Gravity and centrifugalseparation. American IndustrialHygiene Association Quarterly, 11:40, 1950

[20] Barth, W. Brennstoff-Warme-Kraft. 8:1-9. 1956

[21] Iozia, D.L., and Leith, D. AerosolSci. Technol. IO(3): 491-500, 1989

[22] Donna Lee Iozia & David Leith The Logistic Function and Cyclone Fractional Efficiency, Aerosol Science and Technology, 12:3, 598-606, DOI: 10.1080/02786829008959373, 1990

[23] John M. Matsen. Particulate Removal. Encyclopedia of Environmental Science and Engineering CRC Press, 25 Jun 2012, Accessed on: 05 Sep 2023

<https://www.routledgehandbooks.com/doi/10.1081/E-EESE6-120048547>

[24] Stairmand, C.J. The design and performance of cyclone separators, Trans. Inst. Chem. Eng., London, 29, 356, 1951

Comment [NO112]: Please check references format style

UNDER PEER REVIEW