

Implementation of a Real-Time IoT Based Energy Management System

ABSTRACT

Energy Management System has received a lot of attention from both academia and industries due to the rate of energy consumed by electrical appliances. These industries are faced with inflation in the cost of electrical bills. Therefore, this study presents the design and implementation of a real-time IoT based Energy Management System (EMS) to reduce the inflation in the cost of these electrical bills. The system comprises four (4) basic units namely; the sensing unit, control unit, display unit and switching unit. The sensing unit comprises of two sensors namely; Current Transformer (CT) sensor and voltage sensor which senses and measures the parameters (voltage and current) and sends the parameters to the control unit. This control unit comprises two (2) microcontrollers namely; Arduino Nano and ESP32. The Arduino Nano processes the received data from the sensing unit and sends the processed data to the display unit and ESP32 microcontroller for real-time monitoring. In addition, the ESP32 microcontroller sends the processed data to the cloud. Furthermore, the web-based application receives the measured parameters from the cloud and thus, allowing the user to monitor as well as control the rate of energy consumption of electrical appliances. The experimental results obtained showed that the developed system efficiently monitors and control the rate of energy consumption of the three applied loads (Edison 2.7 bulb, standing fan and phone charger). Hence, reduces the cost of electrical bills consumed by these appliances.

Keywords: Arduino Nano, CT Sensor, EMS, ESP32 Microcontroller and Internet of Things (IoT).

1. INTRODUCTION

Due to the rapid development in technology, electrical energy has become an essential part of our day-to-day activities. However, the energy consumed by some of these appliances leads to inflation in the cost of electrical bills[1]. To address this issue, there is need for technologies to be developed in order to monitor as well as control the rate of energy consumption by these appliances. This can be achieved through the utilization of an energy management system [2].

Energy management system (EMS) is a system that optimizes energy consumption through monitoring and measuring electrical energy activities in a particular environment. These systems can be deployed in various areas such as homes, healthcare, logistics as well as industries. Managing electrical appliances can be carried out by collecting and analyzing continuous energy data, identifying optimization in appliances schedules, calculating rate of energy utilized and executing energy optimization solutions [3].

Various techniques exist for the management of electrical energy so as to reduce the amount of energy consumed by electrical appliance. Thus, minimizes the inflation in the cost of electrical bills [2]. In this regard, a load monitoring system was designed and implemented to measure current up to 30A using Current Transformer (CT) Sensor and ESP32 microcontroller as the central controller of the entire system. However, the system only monitors the rate of energy consumed and cannot be remotely controlled by the user.

In this study, the authors seek to improve on the existing techniques by designing an IoT based energy management system. This system monitors and sends a real time data of the measured parameters (Current and Voltage) to the cloud. Hence, enables the user to remotely control the energy consumption via a web application.

The rest of the paper is structured as follows: Section 2 presents the review of related studies, section 3 presents the proposed methodology. The experimental results obtained are presented in section 4, while conclusions are done section 5.

2. RELATED WORKS

This section presents the review of existing studies that have been carried out in the area of Energy Management System (EMS). In this regard, an IoT based real time energy monitoring system using raspberry pi was designed to monitor the consumer's energy usage by Electricity Board (EB) [4]. The system consists of an Electricity Board, which interacts completely through the website and sends the measured data to the consumer using smart phone application. In this system, all communications are carried out via Wi-Fi module of the Raspberry Pi. Furthermore, an LCD was used to display the measured parameter (Voltage and Current). Experimental result shows that the system works efficiently as it displays the electrical parameters measured. However, the system is limited to 5A.

A smart power management system for homes and buildings was presented [5]. The proposed system can monitor and measure electricity usage in real-time. The sensing node used in the project is a hall-effect based AC Current sensor and a transformer-based AC voltage sensor with Arduino Uno microcontroller to calculate the real-time power consumed by electrical appliances. The measured readings are then transmitted wirelessly to the base station using ZigBee. In addition, relay was employed to control the appliances in accordance to the consumer requirements by sending commands wirelessly from the base station to the microcontroller. Experimental result showed the system has the ability to automatically trip off (switch off) whenever the energy consumption exceeds a prescribed/certain limit. Furthermore, the system measures and displays the measured parameter efficiently. However, current sensor is limited to 13 amperes.

An IoT based energy monitoring system was implemented for managing smart homes [6]. The authors employed Arduino Uno, raspberry pi and voltage and current sensors. The system aims at a full power management system and allows the user to see a real time measurement of the power consumption as well as total cost of energy used. Smart meter hardware was used to measure the energy consumption as well as convert the sensed data from analog to digital. Furthermore, an LCD was used to display the output reading. Experimental results show that the proposed system allows the user to monitor the rate of energy consumed in real time. However, current sensor used for measuring the current consumption is limited to 5A only. In addition, the system transmits data to the system on hourly basis.

In [7], an automatic electrical load monitoring, control and alert system was presented. This work sought to design and construct an automatic electrical load monitoring, control and alert system using an Arduino UNO (Atmega328p) microcontroller, which offers real-time alert to users on their energy consumption. The application of this system provided efficient monitoring, control and warning of electrical energy consumption as compared with the traditional energy meters. Experimental result showed that the system is capable of alerting consumers with a beeping signal as soon as consumption exceeds the threshold value. However, the alert system is not enhanced as it does not have wireless technologies such as Wi-Fi, Web, Bluetooth, ZigBee and GSM to improve the alert system through mobile which will enable users to have completed monitoring of their system from a different location.

Furthermore, a smart power monitoring system was designed using IoT to monitor the ratio of electricity consumed and the total amount to be paid [8]. The single-phase electrical power meter was used for monitoring the electrical power consumed in each residence and the PIR sensor sends information to the Arduino. The Arduino then transmits the signal to a relay which will in turn cut off the power when ON. Furthermore, the measured data is being sent to a mobile phone through the GPRS module. Experimental results show that the system enables the user to monitor as well as control the energy consumption of some home appliances remotely. However, this system is limited to only home appliance.

In addition, a load monitoring system was designed and constructed using Arduino Nano as the central controller of the system [9]. The author also utilized a CT sensor to measure the amount of energy consumed by electrical appliances. Furthermore, an LCD was used to display the rate of energy consumption. Experimental results show that the system allows user to monitor the rate of energy consumed by electrical appliances. However, the system can only monitor the amount of energy consumed by the electrical appliance.

In view of these limitations identified from the review of related works, this study seeks to design and implement an IoT based energy management system that monitors and sends a real time data of the measured parameters (Current and Voltage) to the cloud. Hence, enables the user to remotely control the energy consumption via a web application.

3. METHODOLOGY

The overall methodology of the developed system is divided into two phases namely; the hardware implementation phase and the web application phase. The hardware development involved the implementation of the system circuitry modules, whereas the web application phase involved developing a web application for monitoring and controlling the rate of energy consumption remotely. The overall methodology can be summarized in the block diagram presented in Fig 1.

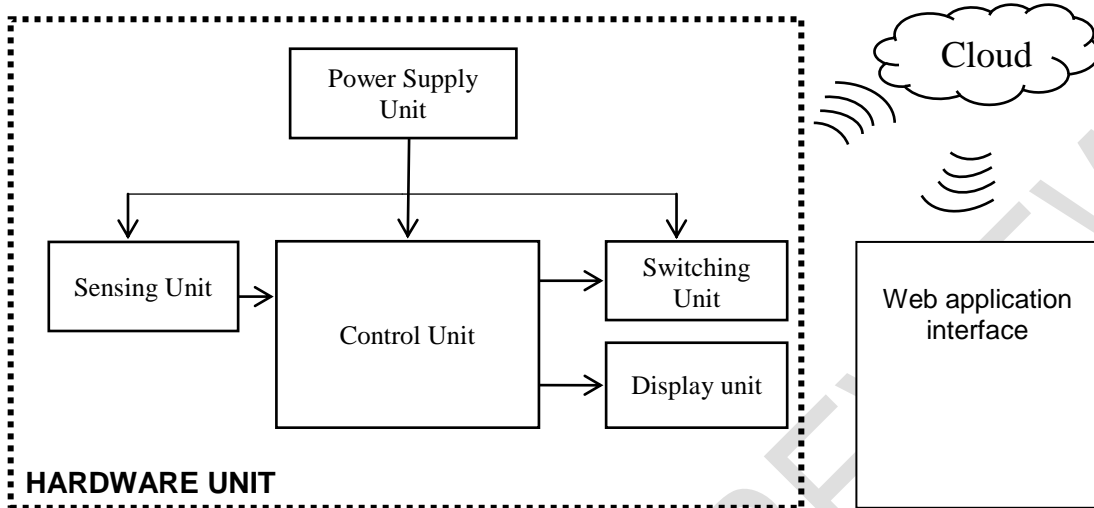

Fig.1. Block Diagram of the Proposed System

3.1 Hardware Implementation

This section presents the step by step procedure followed for the hardware implementation of the proposed system. In the construction of any electronic circuits, some factors have to be considered such as: cost effectiveness, minimum circuit complexity, minimum power dissipation and circuit efficiency. All components selected for the construction were chosen in order to meet the requirement mentioned. Fig 2 presents the block diagram of hardware development. An explanation of the block diagram is presented herewith.

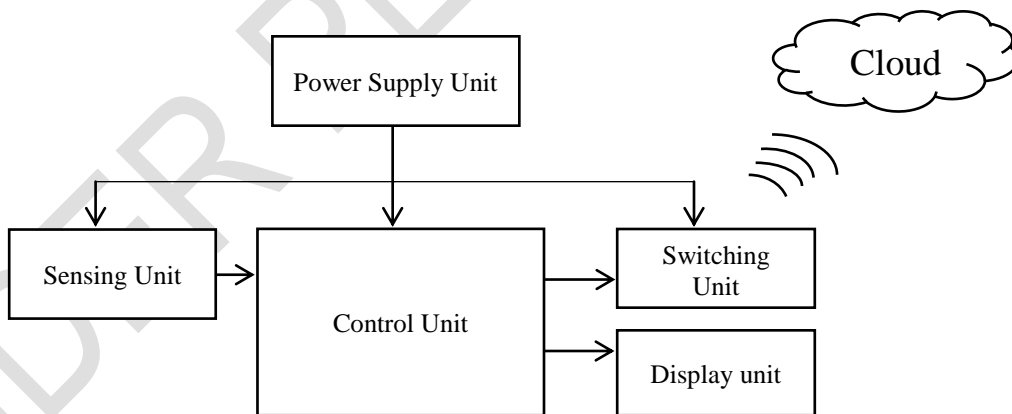

Fig.2. Block Diagram of the Hardware Development Unit

3.1.1 Sensing Unit

This unit measures the amount of energy consumed in real-time. It comprises two basic sub-units namely; the current sensing unit and the voltage sensing unit.

3.1.1.1 Current Sensing Unit

A Current Transformer (CT) sensor was used to measure the amount of current consumed by the applied load. This sensor was employed due to the specifications presented in Table 1.

Table 1. CT Sensor Specifications

Description	Specification
working voltage	5-30V
Input current	5A
Output current	5mA
Operating temperature	40-70 degree Celsius

Table 1 presents the design specifications of the CT Sensor. The current transformer sensor comprises of 4 pins namely; voltage common collector (Vcc), output voltage (Vout), reference voltage (Vref) and Ground (GND). The Vcc is connected to the 5V power supply, while the Vout sends the measured data to the analog pin (A1) of the Arduino Nano. Furthermore, the GND and Vref are connected to the ground. Fig 3 presents the implementation of the current sensor unit.

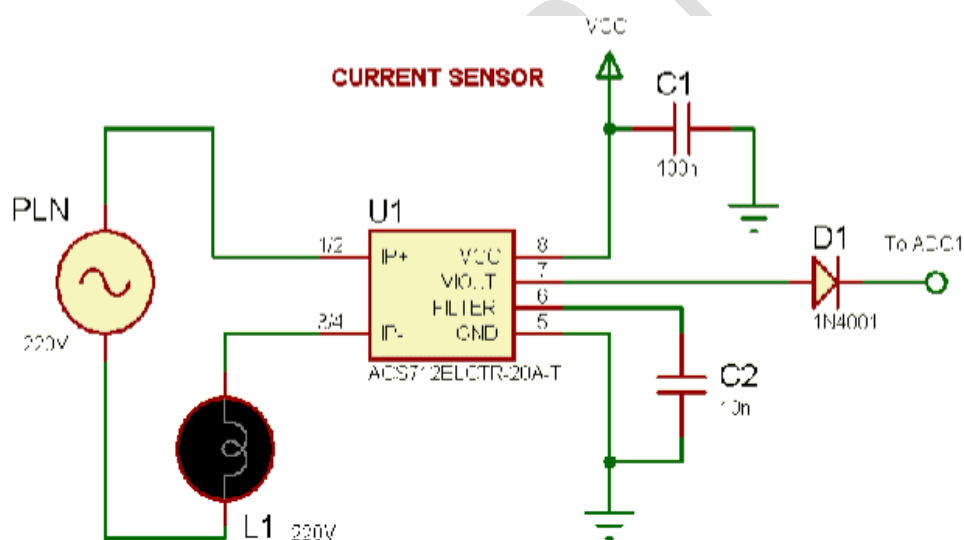

Fig.3. Current Sensing Unit

3.1.1.2 Voltage Sensing Unit

The voltage sensing unit was constructed to measure the amount of voltage sensed from the mains. A 12V step down transformer, three (3) 100kΩ resistors, two (2) 10kΩ resistors and 1μF capacitor were used to construct the voltage sensing unit. Fig 4 presents the voltage sensing unit.

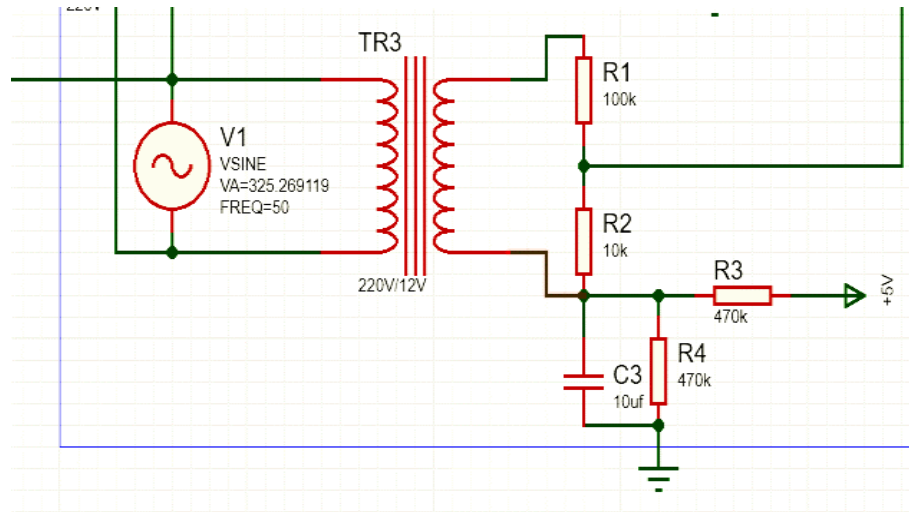

Fig.4. Voltage Sensing Unit

Fig4 presents the construction of the voltage sensing unit. The Vout of the voltage sensor was connected to the analog pin (A0) of the Arduino Nano.

3.1.2 Control Unit

This unit serves as the central controller of the entire system. The unit comprises two microcontrollers namely; the Arduino Nano and ESP 32. The Arduino Nano was interfaced with ESP 32 because the ESP has two (2) analog pins and the developed system requires more than two analog pins. Given this, an Arduino Nano which has 8 analog pins was interfaced with the ESP 32 so as to ensure that the system works efficiently.

This unit works in such a way that the measured parameters (current and voltage) from the sensing unit are first sent to the Arduino Nano through pin A0 and A1 for processing. The Arduino Nano then sends the processed data to the display through pin A4 and A5. Furthermore, it sends the processed data to the ESP 32 through a serial communication. The ESP 32 then sends the received data to the cloud. Fig5 presents the implementation of the control unit

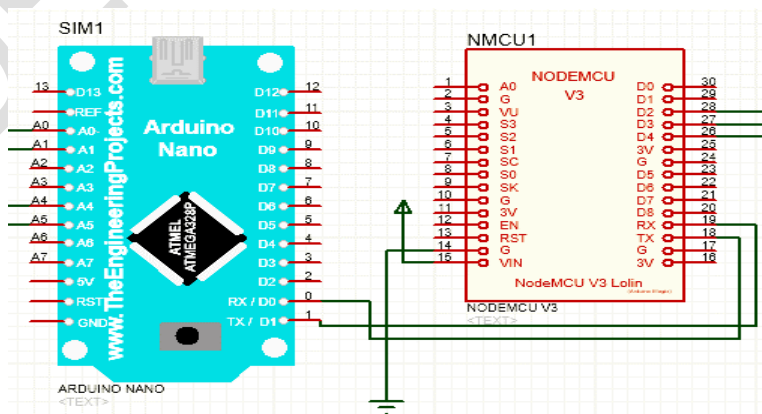

Fig.5. Control Unit

Fig5 presents the interfacing of the Arduino Nano and the ESP 32 in the control unit. These microcontrollers were employed due to the specifications presented in Table 2.

Table 2. ESP 32 and Arduino Nano Specifications

Description	ESP 32 Specifications	Arduino Nano Specifications
Operating voltage	3.0-3.6V	5V
Input voltage	3.3V	7-12V
Analog I/O pins	2	8
Power consumption	80mA	19mA
Bluetooth module	Available	Available
WI-FI module	Available	N/A

3.1.3 Display Unit

In this unit, an LCD 20x4 was used to display the measured parameters in real-time. These readings are sent from the Arduino Nano through pins A4 and A5. Fig6 presents the connection of the LCD and Arduino Nano.

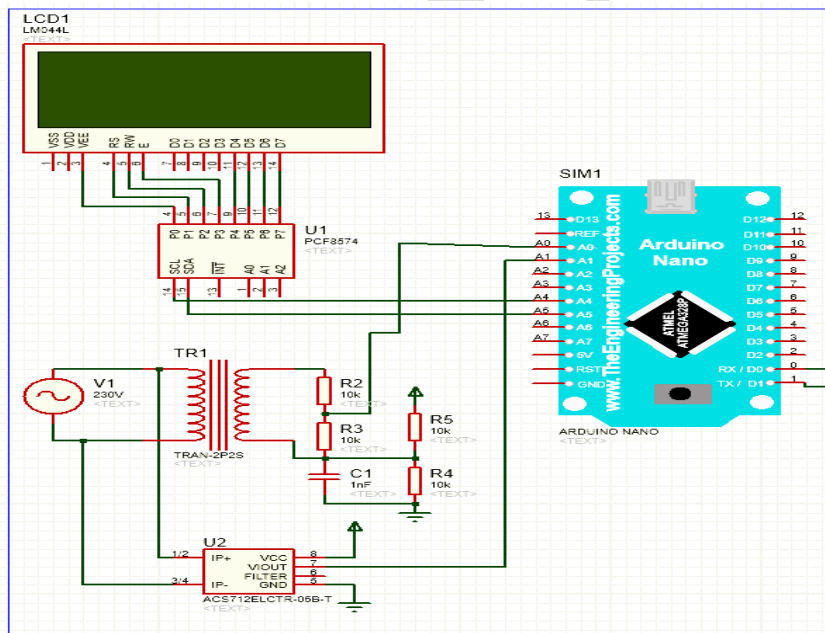

Fig. 6. Display Unit

Fig6 presents the connection between the LCD and Arduino Nano. The connection is in such a way that the GND pin of the LCD is connected to the GND of the Arduino Nano. Furthermore, the Vcc which is the power supply of the LCD was connected to the 5V Vcc pin of the Arduino Nano. Finally, the data bus pins (D0-D7) were connected to the digital output pin of the Arduino. The LCD 20x4 was selected due to the design specifications presented in Table 3.

Table 3. LCD 20x4 Specifications

Parameters	Ratings
Operating voltage	2.7 – 5.5V
Data bus interface	4 – 8 bits
Character display	20 x 4
Module dimension	77.0 x 47.0 mm

3.1.4 Switching Unit

In this unit, a 3-channel relay was used to remotely switch ON/OFF the applied load. This 3-channel relay was used because the developed system comprises 3 major loads (i.e. inductive load, resistive load and capacitive load). In addition, it has a high efficiency of controlling powered devices. This unit is being powered by the ESP 32 microcontroller through its Vcc pin. Fig7 presents the connection between the switching unit and the ESP 32.

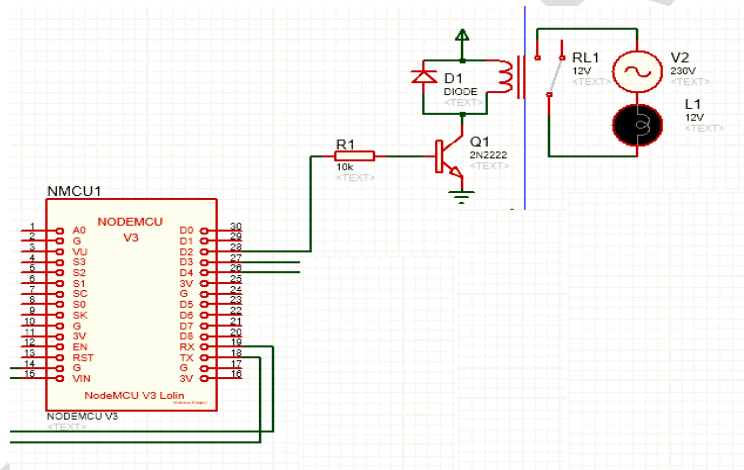

Fig. 7. Switching Unit

Fig7 presents the implementation of the switching unit. The connection is in such a way that the Vcc pin of the relay was connected to the 5V Vcc pin of the ESP 32 microcontroller.

Fig8 presents the overall circuit diagram the hardware development unit. The circuit was designed using the Proteus software to interface the various sub-units of the hardware development unit.

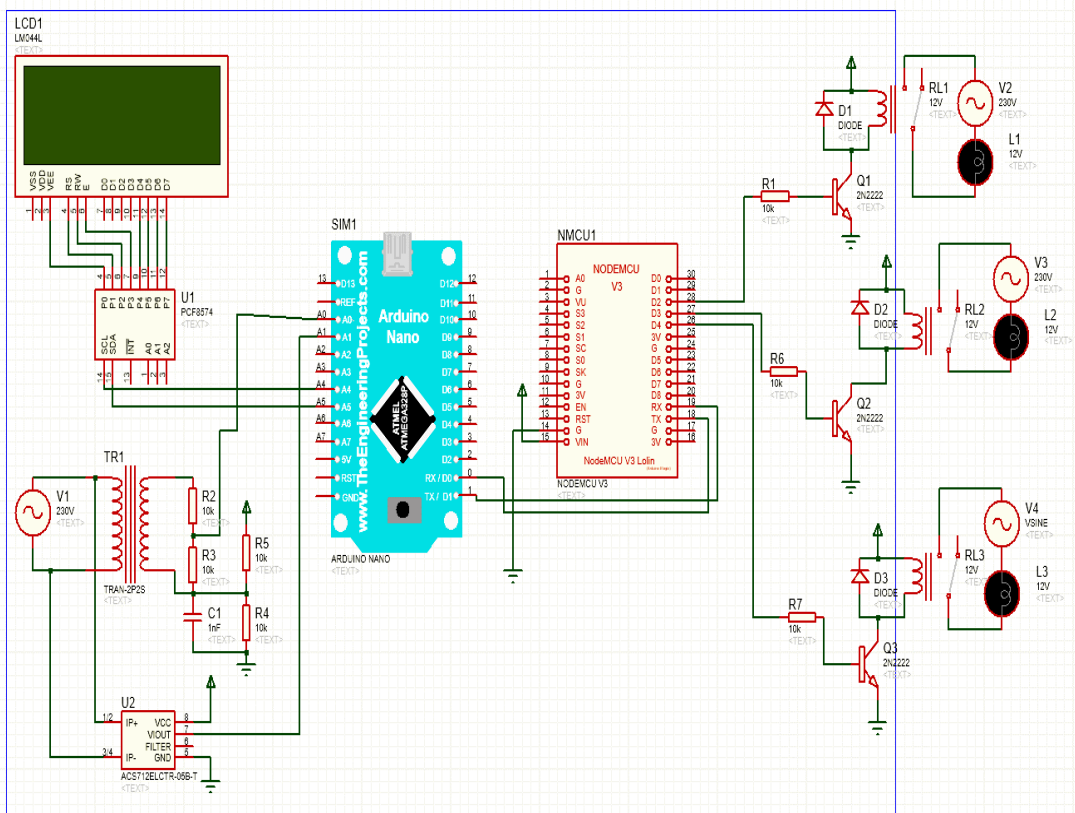

Fig.8. Circuit Diagram of the Hardware Unit

3.2 Web Application Development

In this unit, a client-side interface was designed and developed to enable users, such as homeowners, building occupants, or energy consumers, to remotely monitor as well as control the rate of energy consumption. It provides real-time and historical energy data, insights, and control options. Some key features of the client-side interface include; control options and real-time data display. The control option enables users to manage connected devices or appliances. For example, they can turn off lights, thermostats, or appliances remotely to save energy. Fig9 presents the control option interface, and can be assessed through 192.168.1.101:5000 as the URL.

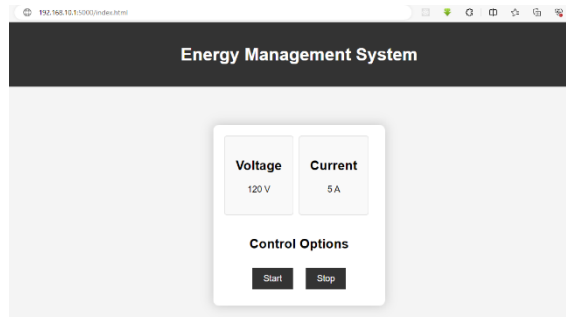

Fig. 9. Control Option Interface

The real-time data display shows real-time data on electricity consumption, including metrics like voltage, current, power, and energy usage. Users can see their current energy consumption and understand how their behavior affects it. Fig10 presents the real-time data interface.



Fig. 10. Real-Time Data Interface

Fig11 presents the flowchart of the developed application

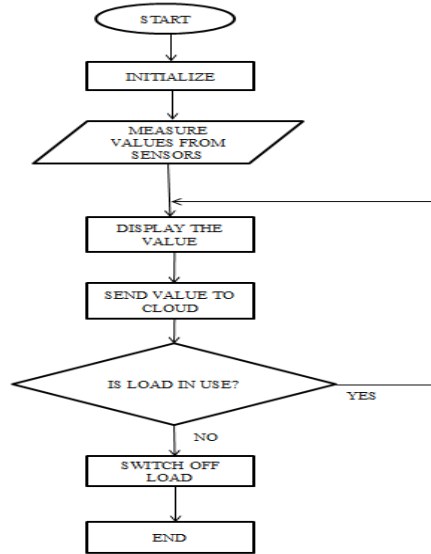

Fig. 11. Flowchart of the Developed Application

4. RESULTS AND DISCUSSION

This section presents the experimental results obtained. Three types of loads were used to test the performance of the developed system namely; resistive load (Edison 2.7 Bulb), inductive Load (Standing fan) and Capacitive Load (Phone charger). Tables 4 to 7 present the energy consumption of these loads at the intervals of 5 minutes.

Table 4. Energy Consumption of Edison Bulb

Time (mins)	Voltage (v)	Current (A)	Energy (W/h)
5	230	0.60	1656.00
10	230	0.67	1924.60
15	230	0.72	2072.40
20	230	1.00	3690.00

Table 4 presents the energy consumption of Edison 2.7 bulb. At constant voltage, the energy consumed by the bulb for 5 minutes is 1656W/h; for 10 minutes, the bulb consumed energy of 1924.6W/h; for 15 minutes, the bulb consumed energy of 2072.4W/h; and for 20 minutes, the bulb consumed energy of 3690W/h respectively.

Table 5. Energy Consumption of Standing Fan

Time (mins)	Voltage (v)	Current (A)	Energy (W/h)
5	230	1.02	2815.20
10	230	1.53	2951.40
15	230	2.31	3125.20
20	230	3.67	3819.30

Table 5 presents the energy consumption of a standing fan. At constant voltage, the energy consumed by the fan for 5 minutes is 2815.2W/h; for 10 minutes, the bulb consumed energy

of 2951.4W/h; for 15 minutes, the bulb consumed energy of 3125.2W/h; and for 20 minutes, the bulb consumed energy of 3819.3W/h respectively.

Table 6. Energy Consumption of Phone Charger

Time (mins)	Voltage (v)	Current (A)	Energy (W/h)
5	230	1.00	1351.40
10	230	1.50	1762.40
15	230	1.77	2051.80
20	230	2.00	2362.40

Table 6. presents the energy consumption of a phone charger. At constant voltage, the energy consumed by the charger for 5 minutes is 1351.4W/h; for 10 minutes, the charger consumed energy of 1762.4W/h; for 15 minutes, the charger consumed energy of 2051.8W/h; and for 20 minutes, the bulb consumed energy of 2362.4W/h respectively.

Table 7. Energy Consumption by the Three Loads Connected Simultaneously

Time (mins)	Voltage (v)	Current (A)	Energy (W/h)
5	230	2.62	2111.40
10	230	3.73	2936.20
15	230	5.24	3246.70
20	230	6.76	3519.10

Table 7 presents the energy consumption of the three (3) appliances. At constant voltage, the energy consumed by the appliances for 5 minutes is 2111.4W/h; for 10 minutes, the three appliances consumed energy of 2936.2W/h; for 15 minutes, the three appliances consumed energy of 3246.7W/h; and for 20 minutes, the bulb consumed energy of 3519.1 respectively.

5. CONCLUSION

In this study, a real-time IoT based energy management system is presented. The system comprises four (4) basic units namely; the sensing unit, control unit, display unit and switching unit. The sensing unit senses and measures the parameter (voltage and current) and sends the parameters to the control unit. This control unit processes the data and sends the processed data to the display units through the LCD for real-time display. In addition, the control unit also sends the processed data to the cloud. Furthermore, the web-based application receives the measured parameters from the cloud thus, allowing user to monitor as well as control the rate of energy consumption of electrical appliances. The results obtained showed that all components and other features have an acceptable level of functionality. Therefore, this study presents an outstanding demonstrator of design, implementation and control capabilities that can be utilized to develop more advanced energy management systems in the future.

REFERENCES

1. Mishra A, Irwin D, Shenoy P, Kurose J, Zhu T. Smartcharge: Cutting the Electricity Bill in Smart Homes with Energy Storage. Proceedings of the 3rd International Conference on Future Energy Systems: Where Energy, Computing and Communication Meet. 2012.
2. Mubarak H, Ardiansyah, A. Prototype Design of IoT (Internet of Things)-based Load Monitoring System. 2020 3rd International Seminar on Research of Information Technology and Intelligent Systems (ISRITI). 2020.
3. Hussien NA, Daleh Al-MagsoosiAA, AIRikabi HT, Abed FT. Monitoring the Consumption of Electrical Energy Based on the Internet of Things Applications. International Journal of Interactive Mobile Technologies. 2021; 15(7).
4. Mudaliar MD, Sivakumar N. IoT based real time energy monitoring system using Raspberry pi. Internet of Things. 2020; 12: 100292.
5. Nayyef IM, Husein A. Design and implementation of IoT based smart power monitoring and management system using WSNS. International Journal of Embedded Systems and Applications (IJESA). 2018; 8(4): 1-16.
6. Agyeman M.O, Guerrero AF, Vien QT. A review of classification techniques for arrhythmia patterns using convolutional neural networks and internet of things (IoT) devices. IEEE access. 2022.
7. Nti IK, Jonas YS, Williams A, Isaac BA, Elvis A. An Automatic Electrical Load Monitoring, Control and Alert System. International Journal of Advanced Research and Publications. 2019;3(7): 6-10.
8. DevadhanishiniAY, Malasri RK, Nandinipriya N, SubashiV, GowriPP. Smart power monitoring system using IoT. In 2019 5th international conference on advanced computing & communication system (ICACCS). 2019; pp. 813-816.
9. Usman IA. Design and Construction of a Load Monitoring System. [Unpublished Manuscript]. 2022.