

EFFICIENT PYROLYSIS OF WOOD CHIPS FEASIBILITY IN UNDERDEVELOPED COUNTRIES: EXPERIMENTATION ON PRODUCT YIELDS

ABSTRACT

This paper is about the feasibility of combustibles gases like methane, ethane and carbon monoxide production from wood pyrolysis. This first laboratory experimental stage objective was to see what products can be obtained from wood pyrolysis in absence of oxygen and presence of nitrogen. The effect of temperature on the product yields was investigated. Products were characterized using gas chromatography. We found that products of wood pyrolysis for temperatures of 700, 800, 900, 1000 and 1100°C were char, CO₂ and combustibles gases like CH₄, C₂H₂, CO and tar. NH₃ was not found in the produced gases.

In our study, condensable gases were not recovered and quantified. A gas condenser would have been necessary inserted for this purpose at the outlet of the pyrolysis reactor before routing the gases to the mass spectrometer.

This study shows that char production decreases from 17.08% at 700°C on the weight basis to 12.95% at 1100°C. Gases and tar production decrease, going from 82.92% at 700 °C on the weight basis to 87.05% at 1100°C.

Carbon dioxide production also increases with temperature. It is the biggest part of produced gases of the wood pyrolysis gases representing an average weight proportion of 6.99% of the initial wood.

Carbon monoxide yield is almost constant, around 1.6% at 800, 900 and 1000°C though its yield at 700°C was found slightly higher accounting for 2.29% weight of the initial wood.

Ethylene (C₂H₄) is only produced in small amount compared to other combustibles gases like methane and carbon monoxide. Its proportion which was observed almost constant, around 0.14% on the weight basis in respect to the initial wood chips weight from 700 to 900°C dropped to 0.02% at 1000°C.

Methane (CH₄) is produced in weight basis proportions of 2.55% which remain almost constant from 700 to 1000°C.

Keywords: Pyrolysis, wood chips, charcoal, combustibles gases, carbon dioxide.

1. INTRODUCTION

Among thermo-chemical treatment (TCT) methods known today, pyrolysis appears as one of the most popular. This is believed to be due to their immense impacts on the environment and their operational output [1]. In their review, Al-Salem et al. mention that the renewed attention that pyrolysis continues to face in recent times is due to the several effective and environmental advantages it offers to today's overall energy demand and fuel scarcity [2].

Pyrolysis is a thermochemical conversion process in the absence of oxygen or other oxidizers at a relatively low temperature as compared to incineration temperatures. This process can be used to recover materials and energy in the form of chemical products and fuels [3].

The total consumption of primary energy in Burkina Faso was estimated to be equal to nearly 2625 Kilotonne in 2008 with a strong dependence on biomass which represents more than 80% of consumed energy [4], [5], [6], [7]. Total consumption of primary energy raised to 4657 Kilotonne in year 2019 with 99% from biomass whereas hydropower and solar photovoltaic represents less than 1% [8], [9], [10].

With more than 90% dependence on biomass energy, only pyrolysis of wood is used in Burkina Faso in the carbonisation process for charcoal production. Unfortunately, this traditional charcoal production process is not energy efficient, because gaseous and liquid products are not recovered. Hence the need for the development of better charcoal production technologies and the development of gasification which is sounder than traditional charcoal production.

Biomass gasification, very little used in Burkina Faso, is one of the most efficient methods for converting biomass into thermal and electrical energy. Despite the abundance of waste of agricultural, vegetable and household origin, the large-scale exploitation of this conversion process is very little developed in Burkina Faso [11], [12]. In a bibliographic review made in 2014, it was established that gasification of waste may be an interesting alternative for Burkina Faso [13]. Other studies on the development of biomass energy in Africa agree with the main conclusions of this review [14], [15], [16].

Taking into account the fact that gasification is preceded by the pyrolysis of biomass, we have conducted this experimental investigation of wood pyrolysis for temperatures of 700 to 1100°C in order to approximately predict product yields of a better charcoal production in Burkina Faso and gasification development.

2. PYROLYSIS OF WOOD

Chen et al. globally represents pyrolysis as a process of thermal degradation of the biomass in the total absence of air that produces recyclable products, including char, oil/wax and combustible gases. This thermal degradation process has been used to produce charcoal from biomass for thousands of years [17]. According to Bridgwater: « Lower process temperature and longer vapour residence times favour the production of charcoal. High temperature and longer residence time increase the biomass conversion to gas and moderate temperature and short vapour residence time are optimum for producing liquids. » [18]

3. EXPERIMENTAL

3.1 Materials

The wood used in these experiments is sawdust dried for at least 24 hours in a steamer and water extractor set at 103°C. Its humidity will therefore be taken equal to zero. The wood grains are approximately cylindrical in shape with lengths of 2 to 3mm and diameters of 0.5 to 2mm.

3.2 Experimental setup

Picture of the experimental setup devices is given on figure 1 below with labels.

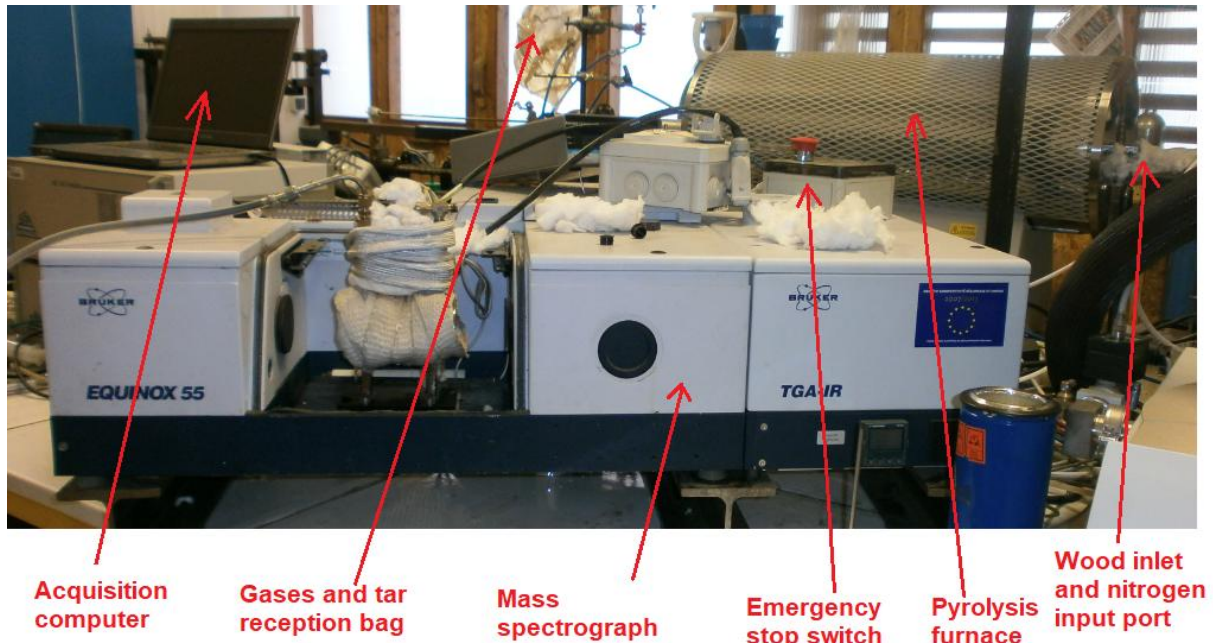

Figure 1: Pyrolysis reactor and measurement apparatuses

This pyrolysis system includes principally three elements as shown in Figure 2 below:

- The pyrolysis oven
- The thermo gravimetric analyzer
- The acquisition computer

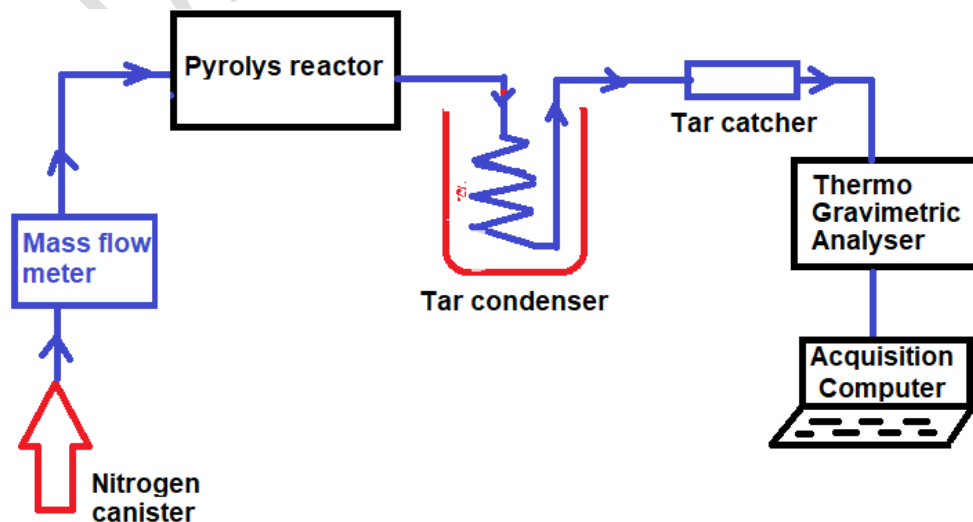

Figure 2: Schematic of the pyrolysis system

3.2.1 The pyrolysis furnace

The pyrolysis reactor is built around a pyrolysis furnace made by Carbolite. This furnace is an electrically heated, cylindrical furnace of which the picture is given on figure 3 below.

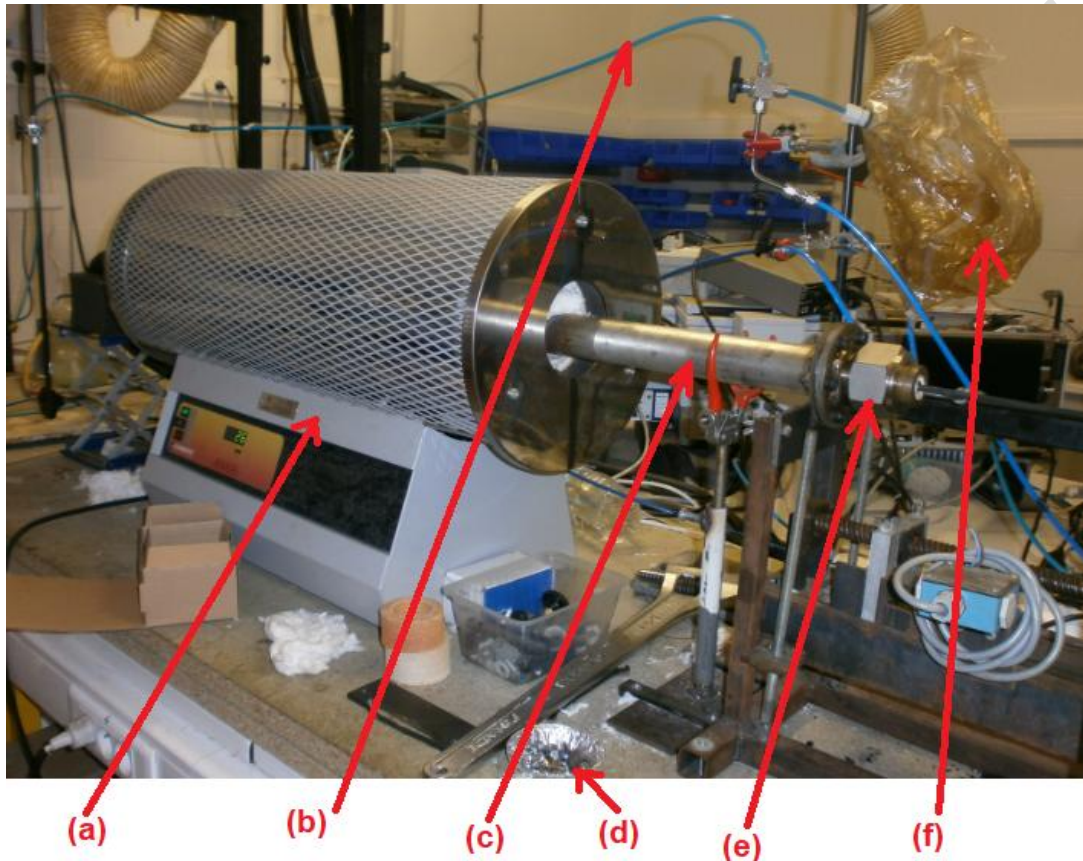
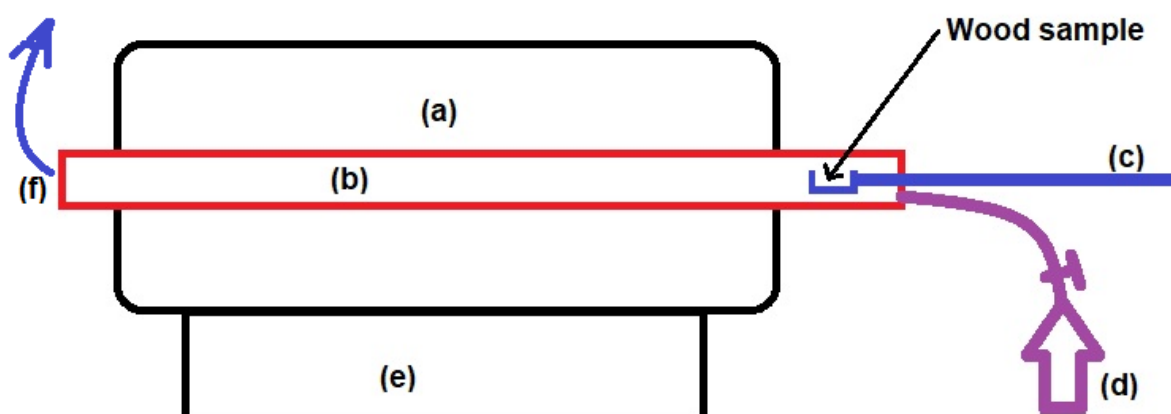

Figure 3: Furnace and support (a), gaseous pyrolysis product exit tube (b), pyrolysis tube (c), sample cup (d), pyrolysis reactor closing cap (e) and gaseous products collection bag (f).

For each experiment, the basket supporting the wood chips is taken out. This basket is cleaned, then the previously weighed dry wood chips are placed on the sample basket. The nacelle is then introduced into the pyrolysis tube using a screw serving as a nacelle guide. Then the cap of the



pyrolysis reactor (e) is closed. We obtain the layout shown schematically in the figure below with the sample guided towards the reactor core:

Figure 4 : Pyrolysis reactor with (a) : Heating envelope, (b) : Pyrolysis cylinder, (c) : Sample holder guide on rack, (d) : Nitrogen canister with flowmeter, (e) : Furnace support, (f) : Pyrolysis products exit

3.2.2 The mass spectrograph

The mass spectrograph made by Bruker is an Equinox 55 thermo-gravimetric analyzer and infrared spectrometer (TGA-IR). This spectrograph is based on infrared absorption spectroscopy. Absorption frequency range goes from 370 to 25000 cm^{-1} . Resolution is better than 0.5 cm^{-1} . It can sample solid, liquids, powders, gas phase. It is driven by OPUS/IR software and is used in this paper to quantify gaseous products from the pyrolysis reactor.

3.2.3 The acquisition computer

On the acquisition computer is installed an Opus 2005 IR software for analyzing different gaseous product from pyrolysis coming from the products collection bag (3.f).

3.3 Experimental protocol:

- 1) Pyrolysis reactor container is cleaned of residual char.
- 2) Mass of wood chips is measured.
- 3) Collection bag is drained of all gases.
- 4) The correct nitrogen flow is controlled.
- 5) Wood chips are introduced in the pyrolysis reactor and the lid is closed.
- 6) Chronometer is started
- 7) The pyrolysis is monitored during 60 seconds.
- 8) Temperature and non-condensable gases yield are monitored until the end of the pyrolysis.
- 9) Pyrolysis reactor is opened to remove produced char
- 10) Masses of charcoal is measured.

4. RESULTS AND DISCUSSION

The mass of the wood chips was measured with a balance with a sensitivity of 0.1 mg. Product yields obtained from pyrolysis for each temperature are summarized in table 1 below.

Table 1 : Used wood mass and products yields

Temperature	700°C			800°C			900°C			1000°C			1100°C		
m_{wood}	1,0030	1,0088	1,0054	1,0042	1,0030	1,0010	1,0015	1,0009	1,0038	1,0033	0,9902	0,9968	0,9932	1,0270	1,0300
m_{char}	0,1750	0,1733	0,1670	0,1578	0,1707	0,1509	0,1462	0,1449	0,1452	0,1376	0,1448	0,1412	0,1331	0,1301	0,1316
m_{gas}	0,8280	0,8355	0,8384	0,8464	0,8323	0,8501	0,8553	0,8560	0,8586	0,8657	0,8453	0,8555	0,8601	0,8969	0,8984
$m_{\text{char}}/m_{\text{wood}}$	0,1745	0,1718	0,1661	0,1571	0,1702	0,1507	0,1460	0,1448	0,1447	0,1371	0,1463	0,1417	0,1340	0,1267	0,1277

$m_{\text{gas}}/m_{\text{wood}}$	0,8255	0,8282	0,8339	0,8429	0,8298	0,8493	0,8540	0,8552	0,8553	0,8629	0,8537	0,8583	0,8660	0,8733	0,8723
Char (Wt %)	17,2%		16,0%			14,5%		14,1%			13,2%				
Gas (Wt %)															

We separated the pyrolysis products into two parts: the solid part consisting of coal and the gaseous part. The gaseous part also includes the tar visible on the gaseous products collection bag. But the tar was not collected separately in this work. Therefore, the gaseous products will be referred to as tar and non-condensable gases in this paper. We note m_{wood} , the mass of the wood sample, m_{char} the mass of the coal, m_{gas} the mass of the gaseous products. For each temperature, three valid measurements are made. By valid measurements we mean the results of a successful test, because if it happened that one of the points of the protocol had been omitted, we repeated the test. The percentage of charcoal is obtained by dividing m_{char} by m_{wood} . Similarly, the percentage of gaseous products is obtained by dividing m_{gas} by m_{wood} .

4.1 Char yield

The figure 5 below gives us the evolution of the percentage of coal in respect to temperature:

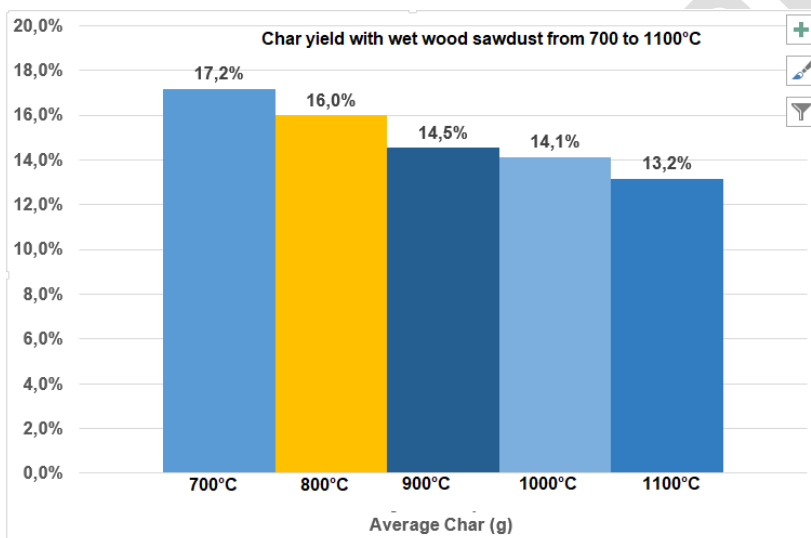

Figure 5: Char yield at different temperatures

Figure 5 above shows that char yield decreases when pyrolysis temperature increases. The decreases seem regular. We can try extrapolating the char yield for lower temperatures to seek for a rough estimation of char yield for temperatures below 700°C.

For that purpose we have plotted the same data as a curve and obtained figure 3 below with an estimation equation. This estimation equation was refined after adjustments and verifications compared to experimental values and temperatures from 700 to 1100°C:

$$\text{Char (wt \%)} = - 0.0099T + 24.1$$

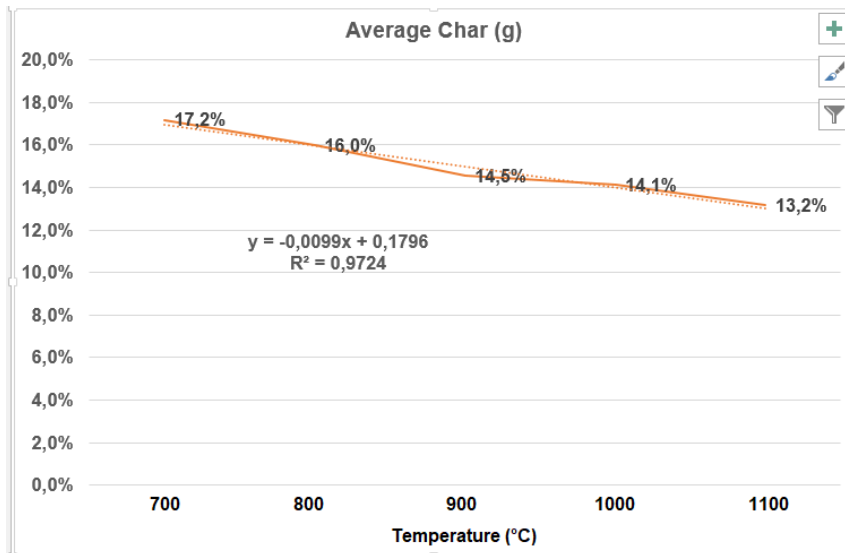

Figure 6: Rough prediction of Charcoal content from wood in fast pyrolysis

Therefore, we would theoretically expect a char yield summarized in table 2 below

Table 2 : Hypothetical char yield from wood pyrolysis at different temperatures

T (°C)	300	400	500	600	700	800	900	1000	1100
Char (%)	21,13	20,14	19,15	18,16	17,17	16,18	15,19	14,2	13,21

This is a purely theoretical assumption and an hypothetical approximation without experimental investigation for temperatures ranging from 300 to 600°C.

Figure 7 below shows that gas products yield account for 82.92% of the pyrolysed wood weight at 700°C to 87.08% of the pyrolysed wood weight at 1100°C.

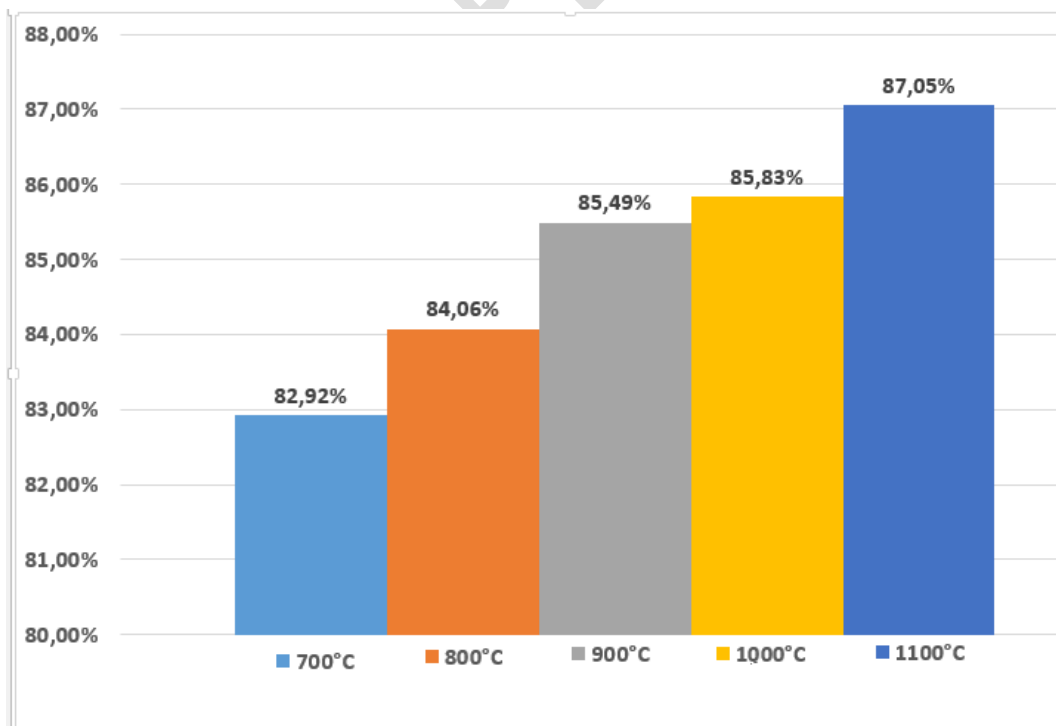

Figure 7: Gases + tar products variation against temperature

It should be noted that at 1000°C, a rapid increase in gas pressure in the reaction chamber due to the rapid devolatilization of the wood chips took us by surprise. Reflux of pyrolysis gases observed on the inlet side of the pyrolysis reactor in the form of smoke. Corrective measures by strengthening the joints of the pyrolysis tube were taken and the nitrogen flow decreased, then the reaction could take place at 1100°C. Despite these experimental precautions, we suspect a slight loss of non-visible pyrolysis products which would explain the apparent stagnation in the quantities of pyrolysis products between 900 and 1000°C.

Figure 7 above shows that gases + tar yield increases when pyrolysis temperature increases. The increases seem regular. We can try extrapolating the char yield for lower temperatures to seek for a rough estimation of char yield for temperatures below 700°C.

For that purpose we have plotted the same data as a curve and obtained Figure 8 below with an estimation equation.

This estimation equation was also refined after adjustments and verifications compared to experimental values and temperatures from 700 to 1100°C:

$$\text{Gases + tar (wt \%)} = 0.00955 T + 76.3000$$

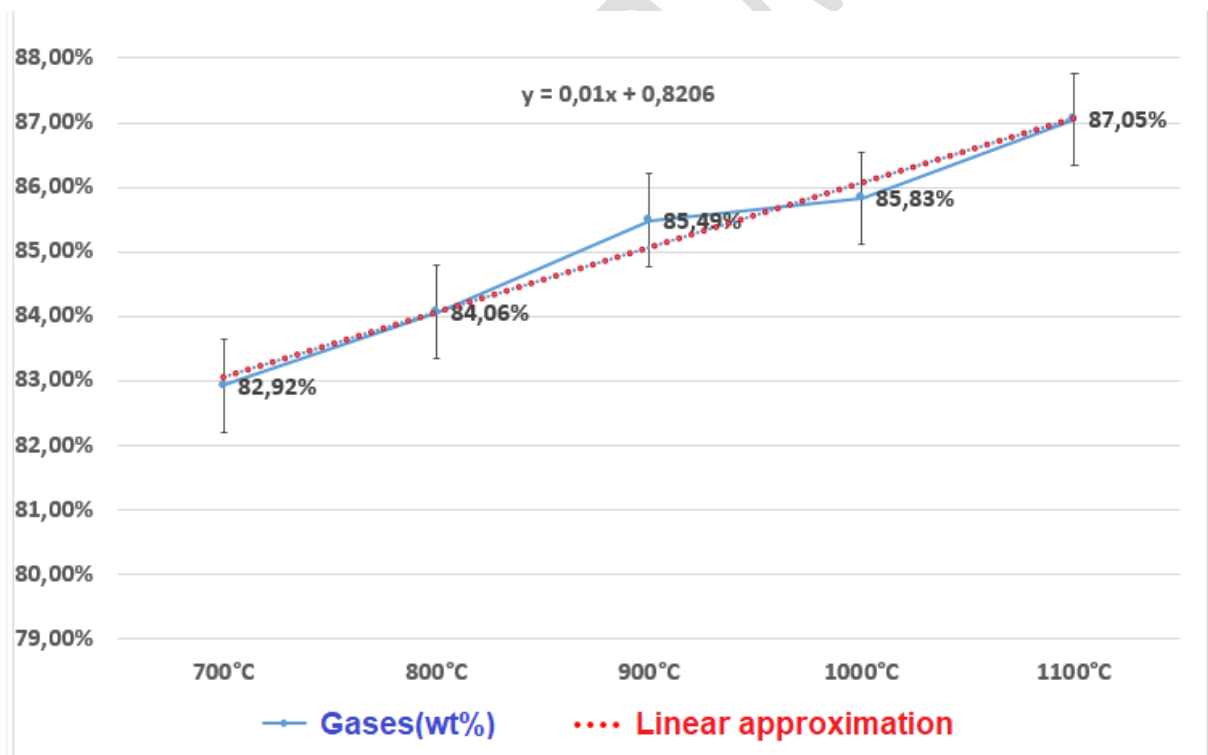

Figure 8: Gaseous products yield

Once again, bearing in mind that this is a purely theoretical and hypothetical approximation, we could theoretically expect a gas and tar yield summarized in Table 3 below.

Table 3: Hypothetical gases + tar yield from wood pyrolysis at different temperatures

T (°C)	300	400	500	600	700	800	900	1000	1100
Gases + tar (%)	79.17	80.12	81.08	82.03	82.96	83.94	84.90	85.85	86.81

If we use the data from Tables 2 and 3, we can roughly estimate gases + tar to be 79.17% of the wood, with charcoal making up 21.13% of the initial mass of the wood at 300°C. These percentages would be 81.08% and 19.15% respectively at 500°C. At these temperatures we would have C₂H₄, CH₄, CO which are combustible and CO₂ which is incombustible.

As quoted by Konstantin Moser et al. [19]: "... One also has to be aware that the yield numbers are only to demonstrate rough differences between technologies and must be seen as approximate values".

4.2 Gaseous products yields

The analysis of gaseous products directly gives their proportions in relation to the mass of the gases.

Dinitrogen (N₂) is introduced into the pyrolysis reactor to ensure pyrolysis in an inert environment and prevent oxidation or gasification of the wood. This nitrogen is indeed present in the gas analysis provided by the TGA-IR, but is not taken into account in the plots of the figures which follow.

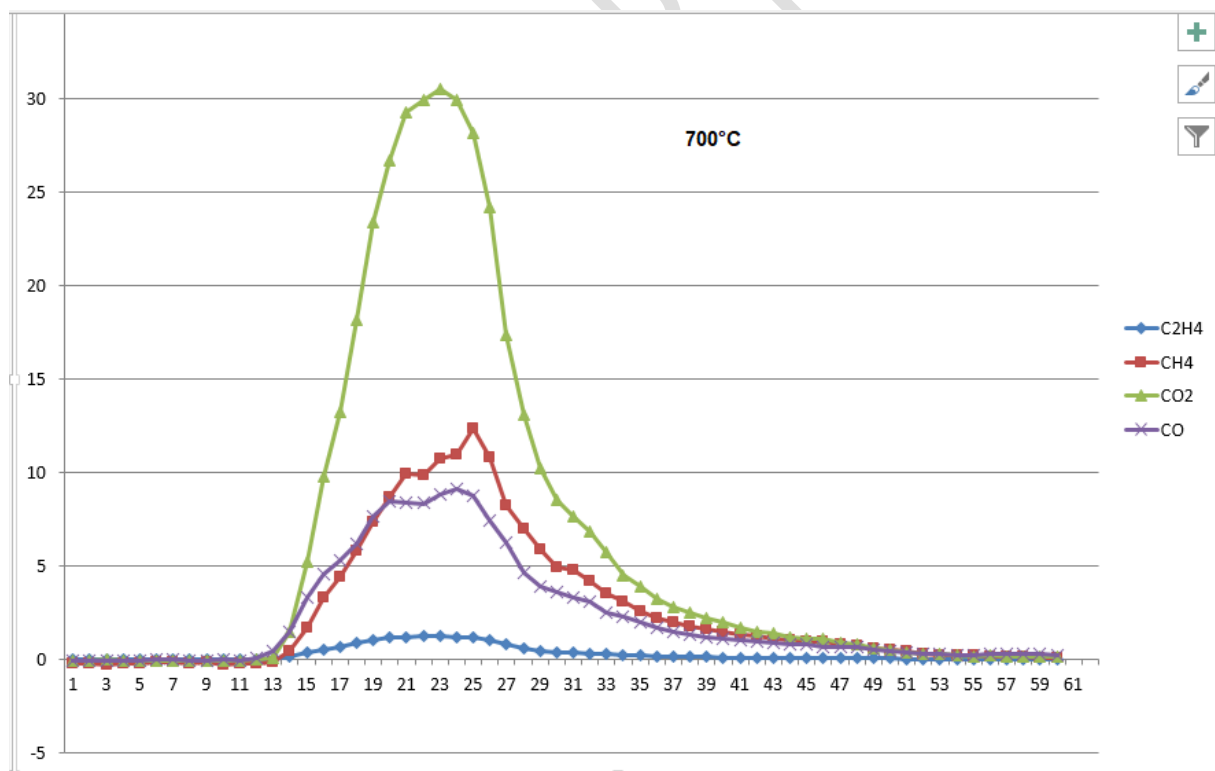

Figure 9 : Dried wood gases yield at 700°C

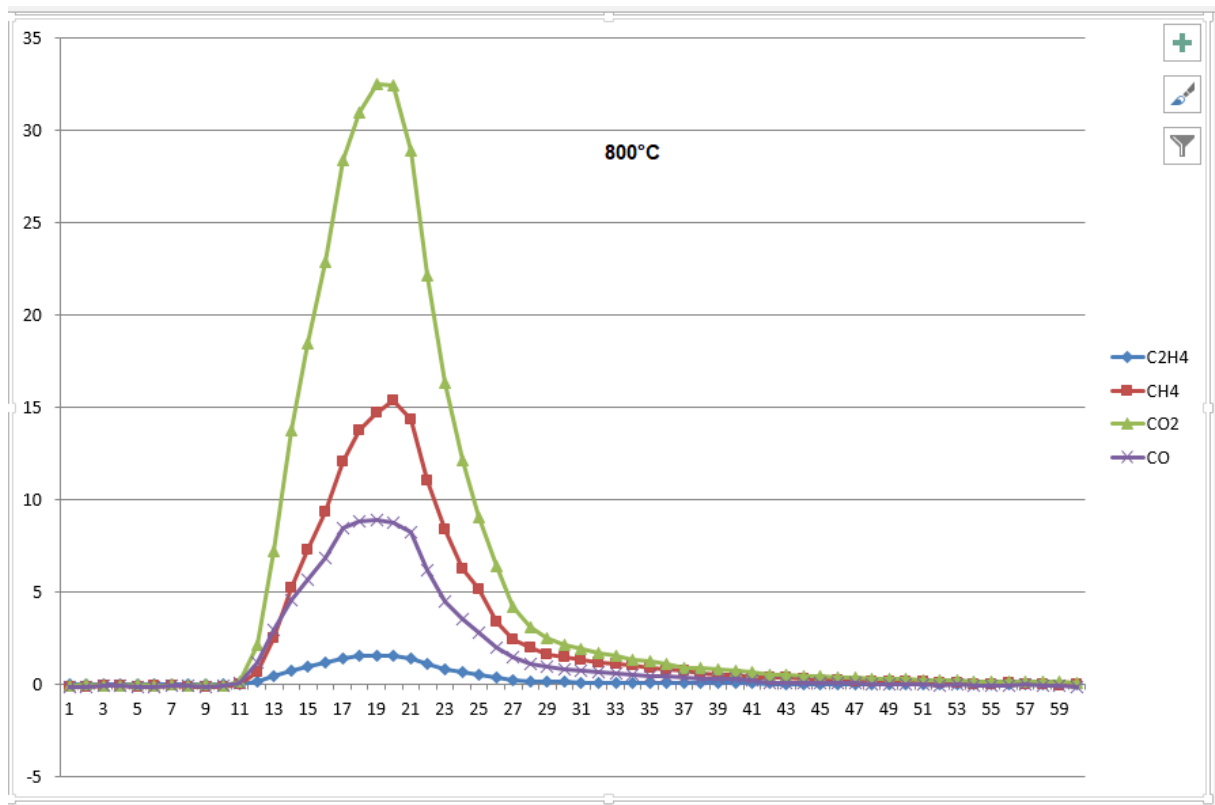

Figure 10: Dried wood gas yield at 800°C

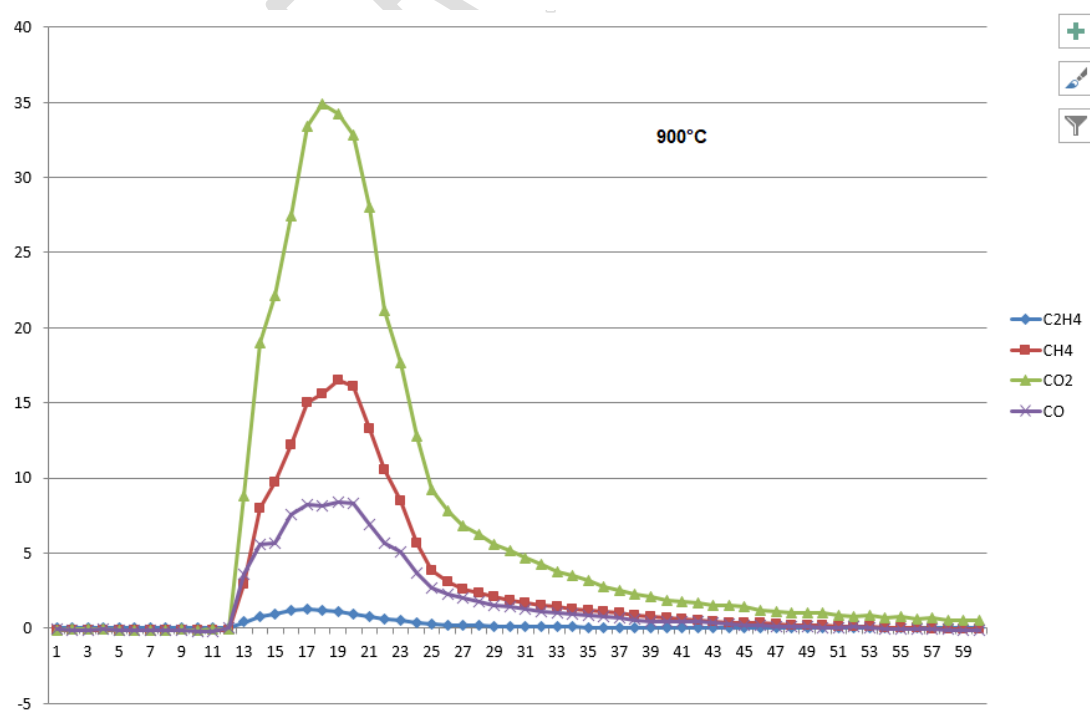

Figure 11 : Dryedwoodgasesyield at 900°C

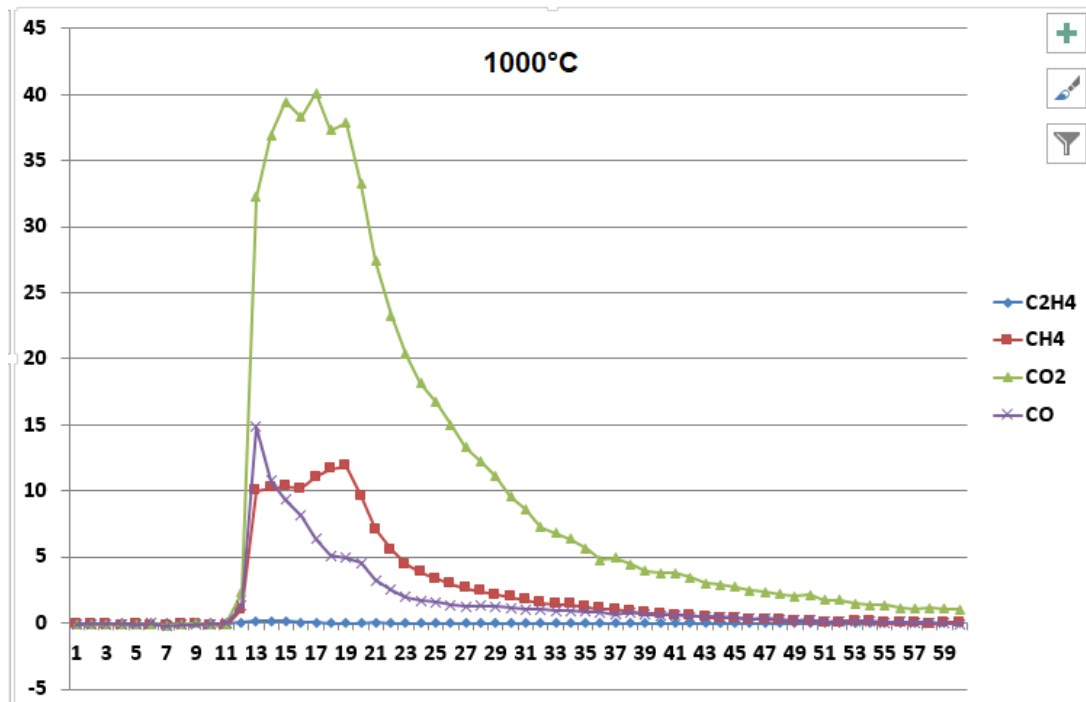

Figure 12 :Dryedwoodgasesyield at 1000°C

We found in this study that while the proportions of other gaseous products vary slightly or remain almost constant, there appears to be a significant shift or exchange between carbon dioxide (CO₂) and ethane (C₂H₄) at 1000 °C. We say this because where C₂H₄ shows a 92% proportional decrease from 900 to 1000°C, the increase in carbon dioxide (CO₂) shows a 46% relative increase from 900 to 1000°C. These significant variations are not observed for the other gases.

Those findings are summarized in figure 13 bellow.

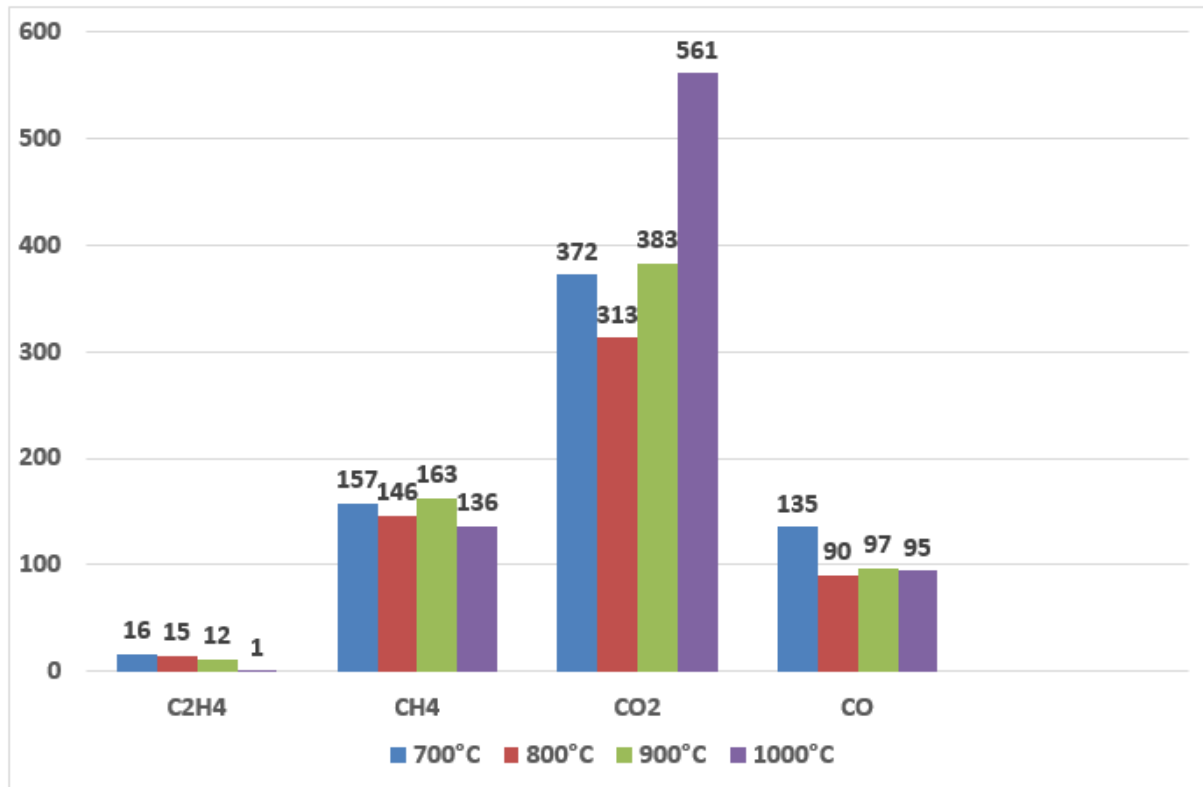

Figure 13 : Cumulative dried wood gas yield by TGA-IR analysis from 700 to 1000°C

The data plotted in Figure 13 above is the sum of the different gas product levels for each experiment, that is, the total gas yield for 60 seconds. We can roughly see that when the temperature increases from 700 to 1000°C: the production of C₂H₄ and CO decreases in relation to their own masses. The CH₄ remains relatively almost constant on the basis of the same criterion. The proportion of CO₂ is in an upward trend always in relation to its own mass.

According to S.W. Banks: fast pyrolysis gases (non-condensable gases) mostly consists of carbon dioxide, carbon monoxide, and methane [20]. Yanik et al. [21] pyrolyzed three agricultural wastes and showed that on the volumes basis, carbon oxides made up 84–90% of the fast pyrolysis product gas, with methane accounting for 6–8 %, hydrogen and hydrocarbon with two to four carbon (C₂H_x and C₄H_y) were found in minor amounts.

Our results are in agreement, though we have not quantified C₄H_y components.

5. CONCLUSION

In this fixed-bed pseudo-batch pyrolysis system reactor, temperatures ranged from 700°C to 1100°C and a maximum non-charcoal production of 85 wt. % was reached. At high temperatures, between 1000°C and 1100°C, devolatilization is strong and brutal. The coal yield obtained was significantly low, less than 12%, meaning that fast pyrolysis of wood could be used as a source of high calorific gas, with coal becoming only a by-product.

Our results are in agreement with those of other authors and we conclude that increasing the pyrolysis temperature of wood favors the production of gaseous products, while it reduces the production of

charcoal. Unfortunately high temperatures also increase the proportion of carbon dioxide in the gases produced.

The challenge we face is the high carbon dioxide content of the gases produced by dry wood pyrolysis. We decide to continue the practical implementation of wood pyrolysis, without injection of nitrogen and at average temperatures, not exceeding 800°C. We have set ourselves a target of a gasification temperature of around 600°C which can be built at affordable costs, with locally available materials in underdeveloped countries like Burkina Faso. We will design and manufacture a rotary kiln pyrolysis reactor without nitrogen supply. This pyrolysis reactor will be designed to operate at moderate temperatures, between 300 and 500°C. We will then test it in several conditions in order to promote the production of liquid and combustible gases. Carbon dioxide must be reduced to the lowest level to comply with environmental protection requirements. Our ultimate project is to combine pyrolysis with gasification in order to obtain an integrated system of energetically self-sufficient pyrolysis and gasification for the conservation of wood into combustible liquids and gases. The encouraging results we have already obtained with wood gasification suggest that the initial heat for the pyrolysis step could be obtained from the gasification unit.

REFERENCES

1Osman Y. Yansaneh and Sharif H. Zein, Recent Advances on Waste Plastic Thermal Pyrolysis: A Critical Overview, *Processes*, 10, 332, 2022. <https://doi.org/10.3390/pr10020332>

2Al-Salem, S.M.; Antelava, A.; Constantinou, A.; Manos, G.; Dutta, A. A review on thermal and catalytic pyrolysis of plastic solidwaste (PSW). *Journal of Environmental Management*, 197, pp. 177–198. 2017

3Stepwise pyrolysis of mixed plastics and paper for separation of oxygenated and hydrocarbon condensates, *Applied Energy*, Elsevier Publisher, Volume 229, 1 November 2018, Pages 314-325, <https://doi.org/10.1016/j.apenergy.2018.08.006>

4Ministry of Energy in Burkina Faso, Energy Strategy 2019-2023; Report, 58 pages, 2018. French

5Dabat M.H, Hanff E, Blin J. Biofuels, an opportunity to reduce poverty in Burkina Faso, 3rd days of research in social sciences. 15 pages, 2009. French

6 Ministry of Mines and Energy of Burkina Faso, Project to harness renewable energies as part of pre-electrification to support rural development, page 5, 1999. French.

[7]Centre for Sustainable & Renewable Energy Studies, Biomass Energy 18 Final.pdf

https://www.crses.sun.ac.za/files/services/schools/biomass_energy/Biomass%20Energy%2018%20Final.pdf, 2018

8K. Stecher A. Brosowski D. Thrän, International Renewable Energy Agency (IRENA), Biomass potential in Africa, https://www.dbfz.de/fileadmin/user_upload/Referenzen/Broschueren/IRENA-DBFZ_Biomass_Potential_in_Africa.pdf, IRENA, 2013

9 Energy policies component of the IFDD Access to Sustainable Energy program, Key figures on energy in Burkina Faso and in the UEMOA area, 2019 Report. French.

10 Ministry of Mines and Energy of Burkina Faso, National Action Plan for Renewable Energy (PANER), https://www.se4all-africa.org/fileadmin/uploads/se4all/Documents/Country_PANER/Burkina_Faso_Plan_d_Actions_National_pour_les_Energies_Renouvelables.pdf, page 6, July 2015. French.

11 Sustainable Energy for All, [Burkina Faso]: Rapid assessment and gap analysis, pp. 1-2, https://www.seforall.org/sites/default/files/Burkina_Faso_RAGA_FR_Released.pdf, Accessed 26 septembre 2023. French.

12 Joan Nyika, Adeolu Adesoji Adediran, Adeniyi Olayanju, Olanrewaju Seun Adesina and Francis Odikpo Edoziuno, The Potential of Biomass in Africa and the Debate on its Carbon Neutrality, Biotechnological Applications of Biomass, DOI: 10.5772/intechopen.93615, 2020

13 Nzihou Jean Fidele, Koulidiati Jean, Segda B. Gérard. Potential and Feasibility of Solid Municipal Waste Treatment with Gasifiers in a Developing Country: A Review for Burkina Faso British Journal of Applied Science & Technology 4(3): 450-464, 2014 SCIENCE DOMAIN international www.sciencedomain.org

14 Wood-Based Biomass Energy Development for Sub-Saharan Africa: Issues and Approaches <https://openknowledge.worldbank.org/entities/publication/9bb75b9a-7102-513b-99be-4895fbff7e2f> ; <http://hdl.handle.net/10986/26149>

15 VENRO, Rethinking Biomass Energy in Sub-Saharan Africa, https://venro.org/fileadmin/user_upload/Dateien/Daten/Publikationen/Factsheets/2009_Afrika_EU_Bioenergiestudie_englisch.pdf 2009

16 Belynda Petrie, Duncan J Macqueen, South African biomass energy: little heeded but much needed, IIED Briefing 4 pages, <https://www.iied.org/sites/default/files/pdfs/migrate/17165IIED.pdf> August 2013

17Dezhen Chen, Lijie Lin, Huan Wang, Pinjin He, Reprint of: pyrolysis technologies for municipal solidwaste: areview, Waste Management, Volume 37, March 2015, Pages 116-136, 2015, <https://doi.org/10.1016/j.wasman.2015.01.022>

18Anthony v. Bridgwater, Biomassfastpyrolysis, Reviewpaper, UDC: 662.73/75, BIBLID: 0354-9836, 8 (2004), 2, 21-49, 2004

19 Konstantin Moser, Elisabeth Wopienka, Christoph Pfeifer, Markus Schwarz, IreneSedlmayer, Walter Haslinger; Screwreactors and rotary kilns in biochar production – A comparative review. Journal of Analytical and AppliedPyrolysis, Volume 174, September 2023, 106112, <https://doi.org/10.1016/j.jaap.2023.106112>

20 S.W. Banks, A.V. Bridgwater, Catalyticfastpyrolysis for improvedliquidquality, Handbook of Biofuels Production (Second Edition), Processes and Technologies, pp. 391-429, <https://doi.org/10.1016/B978-0-08-100455-5.00014-X>, 2016

21Fastpyrolysis of agricultural wastes: Characterization of pyrolysisproducts, Fuel ProcessingTechnology 88(10):942-947, October 2007, DOI:10.1016/j.fuproc.2007.05.002