

Original Research Article

Real-Time Sprinkler Irrigation (RTSI) Scheduling for improving wheat crop water productivity in Vertisols

ABSTRACT

An experiment was conducted at ICAR- Central Institute of Agricultural Engineering (CIAE) Bhopal, Madhya Pradesh, India, during the *rabi* seasons of 2017-18 and 2018-19 with the objectives of to study improved irrigation scheduling for enhancing water productivity of wheat crops in Vertisols. The experiment involved permanent raised bed cultivation in Vertisols and was laid out in Randomized Block Design (RBD) with two planting systems (elevated bed and flatbed) replicated three times. The elevated bed levels were set as 5, 10, 15 and 20 cm. Soil moisture was continuously monitored using a real-time sensor network sprinkler irrigation, during crop growth period. Field data on soil moisture, crop performance, and yield were regularly recorded at different crop growth stages. The results indicated that both conventional sprinkler irrigation and real-time moisture sensor-based sprinkler irrigation led to substantial water savings of 27 and 35%, respectively with corresponding yield increase of 9 and 15% when compared to gravity (flood) irrigation, showing their effectiveness. Soil moisture variability study revealed that average soil moisture levels significantly varied when bed elevation was 10 cm or more, as compared to control (bed with normal field level) in different crop physiological stages. This variation occurred under sprinkler irrigation in Vertisols for recommended irrigation water depth. Under recommended irrigation water application through sprinkler, the wheat crop yield increased for elevation variations up to 10 cm bed elevation and the yield reduced significantly for more than 15 cm bed elevation. For sprinkler irrigation, the developed irrigation water application prescriptions (water depth/irrigation) include 400 mm irrigation depth (ID) for bed of 0 cm elevation, 476 mm ID for bed of 20 cm elevation and 552 mm ID for 30 cm bed elevation to sustain the wheat crop yield under soil moisture variability in Vertisols.

Keywords: Planting systems, Real-time sensor network, Sprinkler irrigation, Water saving, Vertisols

1. INTRODUCTION

“Wheat (*Triticum aestivum L.*) is one of the world's most important staple crops, with over 2.5 billion people consuming it in 89 countries. It is grown on a total of 31.45 million hectares in India, with a production of 107.60 million tonnes and productivity of 3420 kg/ha” (USDA, 2020). “It is farmed on 10 million hectares in Madhya Pradesh, with a total production of 17 million tonnes and productivity of 3298 kg/ha” (Anonymous, 2020). “Water productivity plays an important role in modern agriculture which aims to increase the crop yield per unit of water supplied for irrigation. Among the natural resources, water is the main limiting factor for crop yield in humid sub-tropical or water-limited areas. Thus, irrigation is necessary to maintain high yield in such areas. India's water resources, particularly in the context of agriculture, are facing extreme water stress at different critical stages of crop during its growth. As a result, excessive exploitation of groundwater and surface water is threatening the sustainability of agricultural production in these regions” (Liu *et al.*, 2001; Scanlon *et al.*, 2012). “Adding with heat stress or high temperature stress at this stage of the wheat has detrimental effect on wheat productivity and about 40% wheat area was affected in Indo-Gangetic plains” (Das *et al.* 2014). “Under such environments, irrigation efficiency alongside other potential resource conservation techniques can play a major role to save the scarce natural resources like water” (Rajanna, *et al.*, 2017). “Deficit or limited irrigation (Geerts and Raes, 2009; Du *et al.*, 2015) has been evaluated for wheat crops” (Zhang *et al.*, 2004; Tari, 2016). “Irrigation scheduling is highly location specific and several criteria have been used by researchers for scheduling irrigation in wheat to improve the water productivity.

At the field level water productivity can be improved by minimizing the losses (15–40%) during water application, its distribution and proper irrigation scheduling” (El-Shafei *et al.*, 2022). A specific irrigation scheduling based production technology should be developed to enhance water productivity for sustainable water resource management.

“Irrigation scheduling is crucial for the efficient management of water resources and for optimizing the yield of irrigated areas. The timely identification of crop water stress is crucial for an effective precision irrigation and the reduction of yield losses. Irrigation systems typically result in yields at least twice that of rainfed crops” (Wani *et al.*, 2009). “Besides high-quality seed and the right amount of fertilizer input, irrigation water management plays an all-important role in enhancing crop productivity. Keeping in view, the scarcity and gradual decrease in the share of water for agriculture, the only option available is to produce more food per unit of available water. Conventional surface irrigation practices are employed for more than 80% of India's irrigated area, yet at present their obtainable application efficiency at the field is only about 35-50%” (Shah, 2011). “Sprinkler irrigation, which is the pressurized irrigation system, is recognized as an efficient irrigation technology to get more crop yield per drop” (Krishnamurthi *et al.*, 2003). “It is one of the main irrigation methods in the world because of its water saving and enhanced food productivity potential” (Jiang *et al.*, 2020; Issaka *et al.*, 2018; Uygan *et al.*, 2021). The advantages of adopting sprinkler irrigation over other traditional surface irrigation methods have been reported by several authors (Basso *et al.*, 2003; Kumar and Palanisami, 2010; Pramanik *et al.*, 2016). Effective irrigation scheduling helps in optimizing profit while minimizing inputs such as water and energy cost. Real-time, on-the-go irrigation scheduling can be very effective in improving water management when based on distributed networks of farm-level microclimate and soil water sensor stations that feed into a microprocessor control system to manage irrigations according to rule set established by the producer.

Therefore, this study aims on emphasizing and describing the engineering interventions and to evaluate alternative irrigation system, its techniques and effect on wheat grown in clay soils (Vertisols) in part of central India.

2. MATERIALS AND METHODS

2.1 Study Area

The study was carried out at research farm of Central Institute of Agricultural Engineering (CIAE), Bhopal (23^o 18' to 23^o 20' N and 77^o 24' to 77^o 25' E) with 495 m above mean sea level (AMSL). Winter temperature varies from 10 to 25^o C and summer temperature varies from 25 to 42^o C. Average annual rainfall is 1090 mm confined mainly from mid-June to mid-September. Bhopal district falls under the 5th Agro-climatic region (Vindhya Plateau) of Madhya Pradesh having medium black to deep black soils (Vertisols) and wheat crop zone. Soybean followed by wheat (*Triticum aestivum*) is the main cropping sequence of the state especially in Vertisols. The field experiment consisted of four treatments *viz.*, soil moisture-Decision Support System (DSS) based automated sprinkler irrigation system; timer based automated sprinkler irrigation system, conventional sprinkler irrigation system and border (flood) irrigation system. The experiment was laid out in Randomized Block Design (RBD) with 4 replications of each treatment. The area under each treatment was 0.3 ha. The sprinkler irrigation system (Make: Jain Irrigation Ltd.) with water meters was installed as per the experimental layout for performance evaluation under field conditions. The bulk density of soil (0-30 cm depth) was recorded through standard procedure. Soil compaction/settlement of the soil was measured with the help of cone penetrometer. The method consists of pushing

an instrumented cone, with the tip facing down, into the ground at a controlled rate (controlled between 1.5 -2.5 cm/s).

The soil moisture sensor was calibrated by comparing measured field soil moisture and recorded soil moisture through sensor. Regression equation *i.e.*, $Y = mx + b$ was used for the calibration purpose

Where,

Y = Dependent variable (soil water content)

m = Slope of the regression equation

x = independent variable and

b = Constant

2.2 Telemetry based Real Time Irrigation Scheduling using Soil Moisture Sensor

Telemetry based real time sprinkler irrigation scheduling system using soil moisture sensors was installed in the field. The network starts with a soil moisture sensor (MP406), an air temperature sensor grouped together in a data logger (Smart logger, Model SL5-1L, 200 channels, ICT International, Australia). Each zone had one standing wave soil moisture probes (SMP) (MP406 soil moisture sensor, ICT International, Australia) to measure volumetric soil water content. These sensors were connected to radios which were programmed to send data back at designated intervals to a radio base station (Instrumentation Cell) to receive signals from the outlying radio field stations. The network was designed in such a way that any future expansion of new sensors could be accommodated. The cable leads of all four sensors were connected to an SMD4-P smart interface, which in turn was connected to the data logger at the field edge. The soil temperature (Model TM4, ICT International) was used to correct the SMP calibrations. The data logger was programmed to monitor the soil moisture and controlled the irrigations for each zone individually. The Smart data logger was programmed to make irrigation decisions every 12 hours. Zones were irrigated for 8 hours if the SMP threshold was exceeded. The data logger controlled the irrigations using an SMD4-P controller to which the solenoid valves at each zone were connected. The data logger was powered by a solar panel and the controller was powered by 24 V AC. It not only stores all the information coming in, but controls how often the readings are made and transmit data to desktop computer (Instrumentation Cell) through telemetry system. Data logger is connected to a modem which downloads the information using the mobile phone network onto a **File Transfer Protocol (FTP)** server. DSS and telemetry system for field irrigation developed by ICT International, Australia is shown in Fig 1. Specialist software developed for data downloading through telemetry archives and manipulates the data and presents it for irrigation scheduling. The installed DSS and soil moisture based real time sprinkler irrigation system was tested and evaluated and was found to be working properly during *rabi* 2017-18 to *rabi* 2018-19.

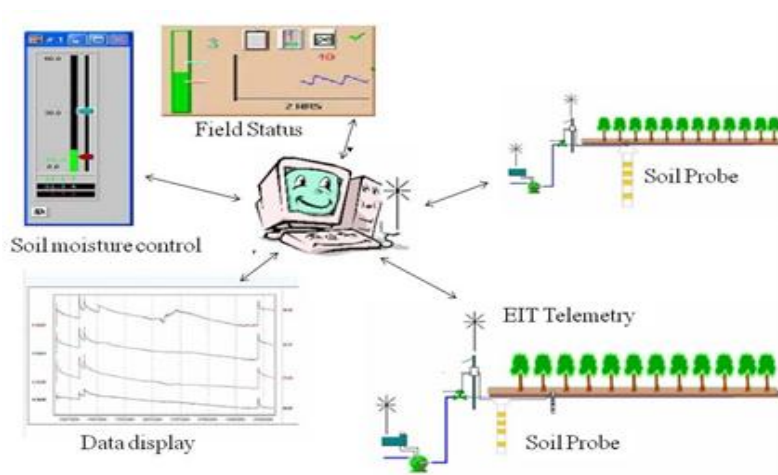

Fig. 1. DSS and telemetry system for field irrigation (ICT International, Australia)

2.3 Calibration of Soil Moisture Probes/Sensors and Irrigation Scheduling

The soil moisture sensors (MP406) (20 Nos.) were installed at 15 and 30 cm depths in irrigated wheat crop field. The real time soil moisture data was recorded at 6-hour interval by the sensors during *rabi* 2017-18 and 2018-19 season was transmitted effectively to a PC through transmitter and receiver using the mobile phone network. The actual soil moisture of collected soil sample was determined using gravimetric method for calibration of soil moisture sensors (Fig. 2a and 2b). The soil moisture sensor was calibrated by comparing measured field soil moisture and recorded soil moisture through sensor. Irrigation scheduling for different crops requires planning and knowledge of water requirement. Water balance study using non-weighing type lysimeters was carried out during *rabi* 2017-18 and 2018-19 for wheat crop (*Variety –HI 1544*). The soil physical properties (bulk density, field capacity and permanent wilting point) were measured. Threshold values of volumetric soil moisture content for automated SI system at varying maximum allowable deficit (MAD) levels were determined.

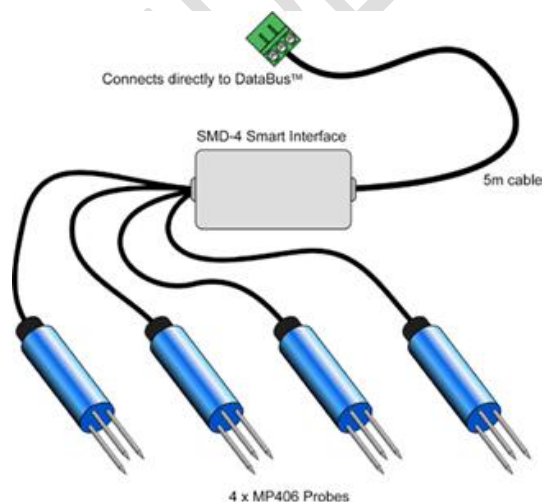

Fig. 2 (a). 4 x MP406 Probes with Smart Interface



Fig. 2 (b). DSS based Real Time Sprinkler Irrigation System

The field experiment on water saving and water productivity as per treatment details were carried out during *rabi* 2017-18 to *rabi* 2018-19 for wheat crop (variety – *HI-1544*) by adopting recommended cultivation practices of mechanized farming. Three irrigations including pre-sowing irrigation were applied at 30 days interval considering scarcity of irrigation water under flood irrigation method. The depth of irrigation applied was 7.5 cm for sprinkler irrigation and 10 cm for flood method. Crop performance parameters (plant growth attributes, yield and yield attributes) were recorded at regular interval. Irrigation to wheat crop under real time soil moisture-based sprinkler system was provided at 50% MAD level.

The field experiment was also conducted to evaluate the effect of varying topography using treatments having six bed elevation level (D_0 - 0 cm D_1 - 50cm, D_2 - 100cm, D_3 - 150cm, D_4 - 200cm, and D_5 - 300 cm) on growth and yield of wheat under recommended irrigation using sprinkler system during *rabi* seasons of the years 2017-18 to 2018-19. The experiment was carried out for permanent raised bed cultivation of soybean-wheat cropping systems in Vertisols and was laid out in randomized block design with two planting systems (elevated bed and flatbed) and replicated three times. The soil moisture was monitored continuously using sensor network. During crop growth period field data on soil moisture, crop performance and yield were recorded at regular interval for different crop growth stages.

3. RESULTS AND DISCUSSIONS

In order to ascertain proper compaction of formed beds of different elevations/ heights during *rabi* 2016-17 resembling with natural condition, two soil properties *i.e.*, soil bulk density and cone penetration index (CPI) were measured/determined during *rabi* 2017-18 and 2018-19. Soil bulk density was measured for two soil depth ranges: 0-15 cm and 15 – 30 cm (Fig 3) and cone index (Fig 4) in depth of soil 0-30 cm.

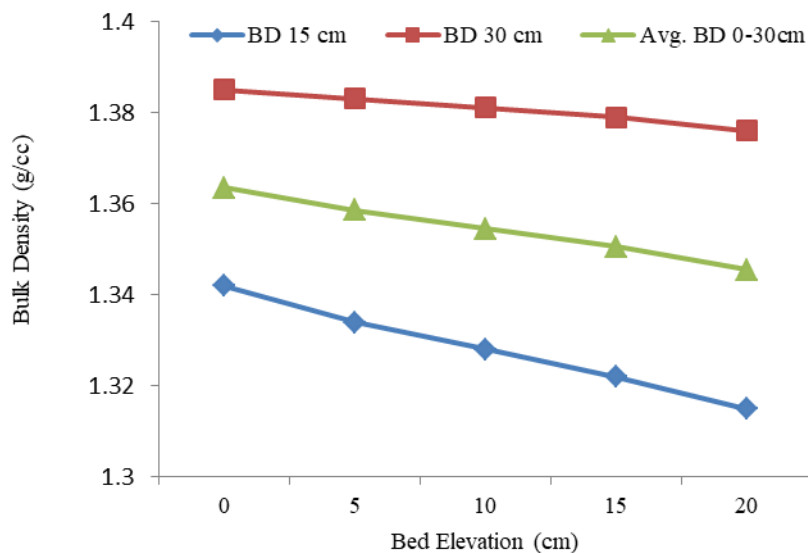

Fig. 3. Variation of bulk density at 24.85% moisture content in *rabi* 2018-19

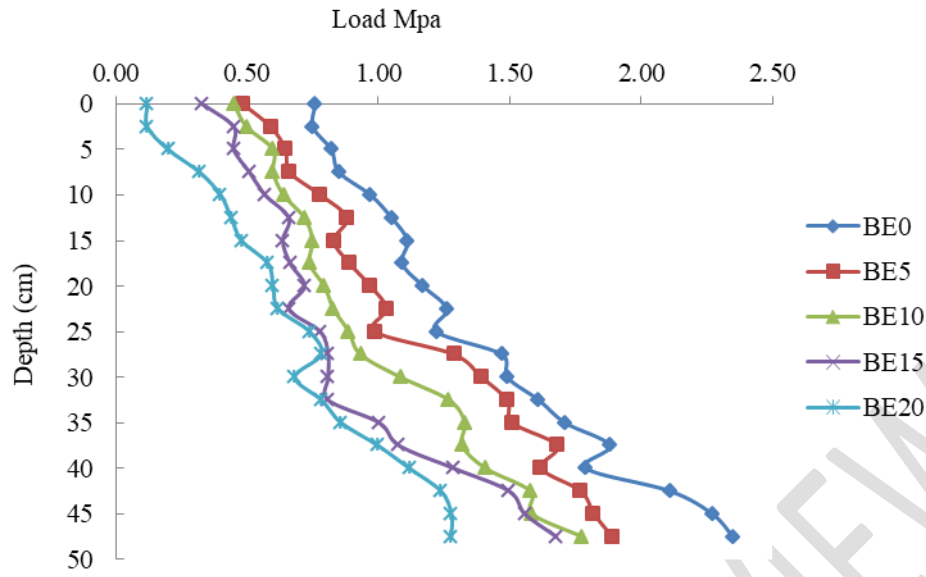

Fig. 4. Variation of Cone Penetration Index (CPI) values

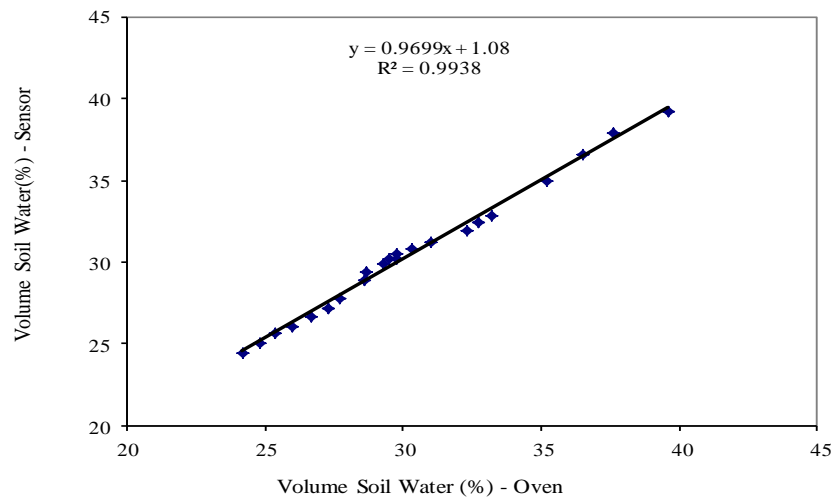

Fig. 5. Soil moisture sensor calibration curve

After two years of bed formation, elevated beds attained the compaction/consolidation comparable with natural soil compaction depth. There was no significant difference noticed in bulk density of formed beds of varying elevations as compared to control (Bed representing actual field elevation/depth.)

3.1 Calibration of Soil Moisture Probes/Sensors

The soil moisture sensor was calibrated by comparing measured field soil moisture and recorded soil moisture through sensor. The measured values of field soil moisture through oven method and soil moisture recorded through sensor were found to be in close agreement (Fig. 5), which indicates the suitability of soil moisture MP406 sensor for precise field soil moisture measurement for Vertisols.

3.2 Field Soil Moisture Variability and Irrigation Scheduling

Soil moisture data for two soil depths (i.e., 0-15 cm and 15 -30 cm) under different treatments were recorded through sensors as well as through gravimetric method at regular interval of 3 days during crop growth period. The average soil moisture variation for different crop growth stages under different treatment during two seasons (*rabi-2017-18* and *rabi-2018-19*) are presented in Figure 6. The soil moisture reduced significantly at 5% depth during different crop growth stages for bed elevation of 10 cm or more as compared to control (bed with zero elevation). The relationships/equations between average soil moisture and bed elevations for predicting average soil moisture at different crop physiological stages were developed to ascertain irrigation need (Table 1 and Figure 6). In the developed equations the value of dependent variable i.e., Y is the soil moisture on dry weight basis (SM_{dwb}) in percentage and the values of independent variable (X) are the bed elevation in cm with increment of 5 cm starting from zero (i.e., 0, 5, 10, 15, 20 cm and so on). The R^2 value of developed equations varies from 0.975 to 0.981.

Table 1. Soil Moisture Equations for different physiological stages of crop

Crop Stages	Soil Moisture Equation, Y=SM% (dwb) & X= Bed height in cm	R ² Values
GS-DAS 13	$Y = -0.002X^2 - 0.009X + 27.93$	0.974
TS- DAS 33	$Y = -0.001X^2 - 0.044X + 27.03$	0.979
BS-DAS 52	$Y = -0.001X^2 - 0.046X + 27.80$	0.983
EHBS- DAS 70	$Y = -0.0008X^2 - 0.033X + 27.60$	0.973
MGS- DAS 91	$Y = -0.002X^2 - 0.048X + 27.86$	0.968
MS- DAS 106	$Y = -0.001X^2 - 0.040X + 25.75$	0.984

* GS=Germination stage, TS=Tillering stage, BS=Booting stage, EHBS=Ear Head Bearing stage, MGS=Milky Grain Formation stage, MS=Maturity stage and DAS=Days after sowing.

Figure 6 shows soil moisture variability with varying bed elevations for different crop growth stages under recommended irrigation. In general, average soil moisture is showing decreasing trend with increasing bed elevation. Pictorial representation of soil moisture variability and soil moisture movement pattern under beds of varying elevations is shown in Fig 7 for different crop growth stages.

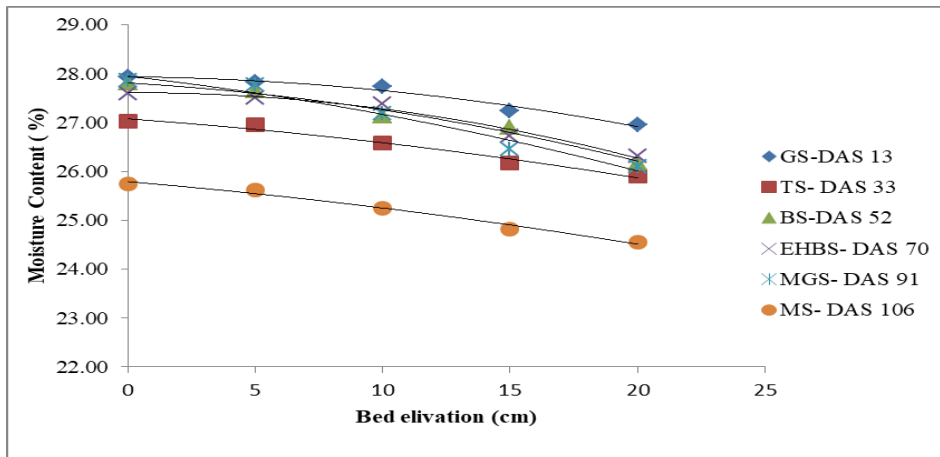

Fig. 6. Avg. soil moisture variability in ID-Recommended (*Rabi* 2017-18 and 2018-19)

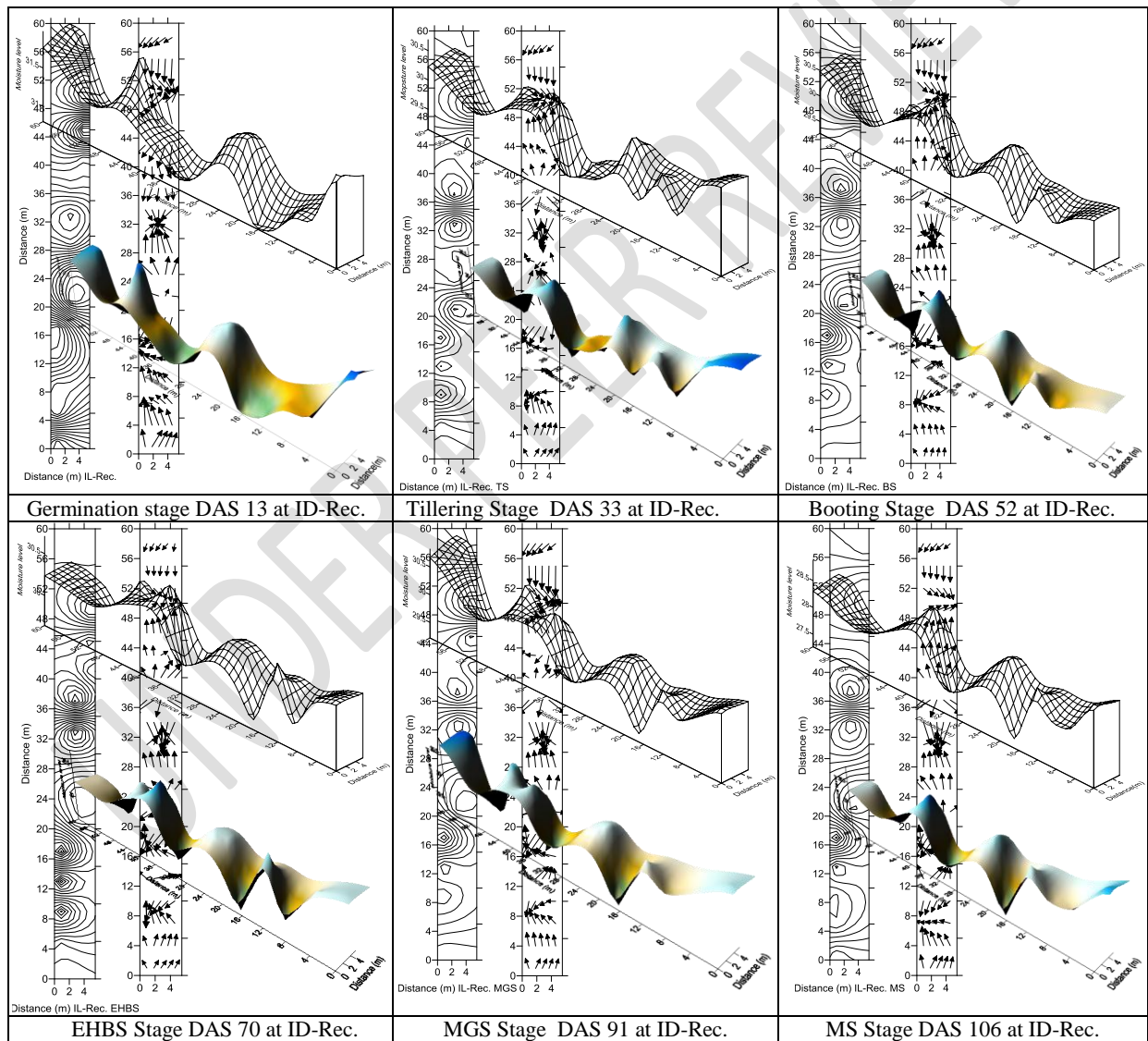

Fig. 7. Soil moisture content variation for different crop physiological stages in recommended irrigation depth

Water balance study using non-weighing type lysimeters was carried out for wheat crop. The average values of various components of water balance equation ($P + I = RO + S + DL + CWU$) for crop growth period were observed to be 318 mm applied irrigation water (I), 57.6 mm rainfall, 0.0 mm surface runoff (RO), 23.1 mm change in soil moisture storage (S), 0.0 mm deep percolation losses (DL) and 352.5 mm crop water use (CWU). The average value of actual water requirement of wheat from field experimentation was found to be 352.5 mm. The average values of soil bulk density, field capacity and permanent wilting point for top soil (0-30 cm depth) of experimental field were found to be 1.43 g/cc, 31.94% and 18.10% respectively on dry weight basis. Threshold values of volumetric soil moisture content for automated SI system in Vertisols at varying MAD levels were determined and were observed to be 37.7 and 35.8% for 40 and 50% MAD levels respectively. The soil moisture content based on volumetric basis varied from 16.5 to 44.8%. Irrigation was applied under at 50% MAD level. The soil moisture data recorded through sensors were also compared with actual soil moisture measurement using gravimetric method and were found to be in close agreement.

3.3 Water Saving and Efficiencies in Irrigation Systems

The quantity of irrigation water applied, water application efficiency, crop yield and water productivity obtained under sprinkler and flood irrigation methods are presented in Table 2. Under flood method of irrigation, average water application efficiency and water productivity were found to be 65.65% and 16.23 kg/ha/mm of water in Vertisols. Conventional sprinkler irrigation and RTSM based Sprinkler irrigation resulted in average 25.45 and 53.94% water saving respectively as compared to flood irrigation for wheat crop in Vertisols. For sprinkler irrigation average water application efficiency and water productivity were found to be 74.25% and 23.55 kg/ha/mm of water. For RTSM based sprinkler irrigation average water application efficiency and water productivity were found to be 77.95% and 27.37 kg/ha/mm of water. Conventional sprinkler irrigation and real time soil moisture-based sprinkler irrigation for wheat crop (*variety: HI-1544*) in Vertisols resulted in 12.83 and 20.24 % yield increase over the control (flood irrigation system), respectively. In case of real time sprinkler irrigation scheduling significant water, saving was observed in comparison to flood and sprinkler irrigation scheduling.

Table 2. Water saving and productivity for wheat under different irrigation methods

Sl. No.	Particular	Conventional Sprinkler irrigation	Flood irrigation (Control)	%Change w.r.t. control (average)	Real time soil moisture (RTSM)based sprinkler irrigation	%Change w.r.t. control
1.	Water quantity applied (m ³)	2230-2280	2910-3140	27.6	1920- 2010	34.7
2.	Water application efficiency (%)	73.20 - 75.30	64.40 -66.90	17.00	76.30 -79.60	20.21
3.	Crop yield (t/ha)	4.81 - 5.39	4.17 -4.87	9.30	5.26-5.61	15.27
4.	Water productivity (kg/ha/mm)	23.50-23.60	15.95-16.50	40.00	26.83 -27.91	66.80

3.4 Effect of Spatial Soil Moisture Variability on Wheat Crop Yield

The variation in grain yield of wheat crop under varying bed elevations is presented in Table 3. The grain yield values indicated decreasing trend with respect to increasing bed elevation as compared to the control *i.e.*, flatbed (Fig 8). The grain yield of wheat decreased significantly in bed elevations more than 15 cm to the control.

Table 3. Yield (t/ha) variation for different bed elevation w.r.t. irrigation depths

Bed Elevation	Recommended Irrigation depth (ID1.0)			
	Yield (t/ha)		Yield variation w.r.t. Control (%)	
	Rabi 2017-18	Rabi 2018-19	Rabi 2017-18	Rabi 2018-19
BE0	4.47	5.14	0.00	0.00
BE5	4.62	5.30	3.35	3.11
BE10	4.82	5.49	7.82	6.80
BE15	4.33	4.93	-3.13	-4.09
BE20	4.09	4.66	-8.50	-9.33
SEm ±		0.143		
CD %		0.330		
BE25		3.90*	* Predicted yield value	
BE30		2.98*		

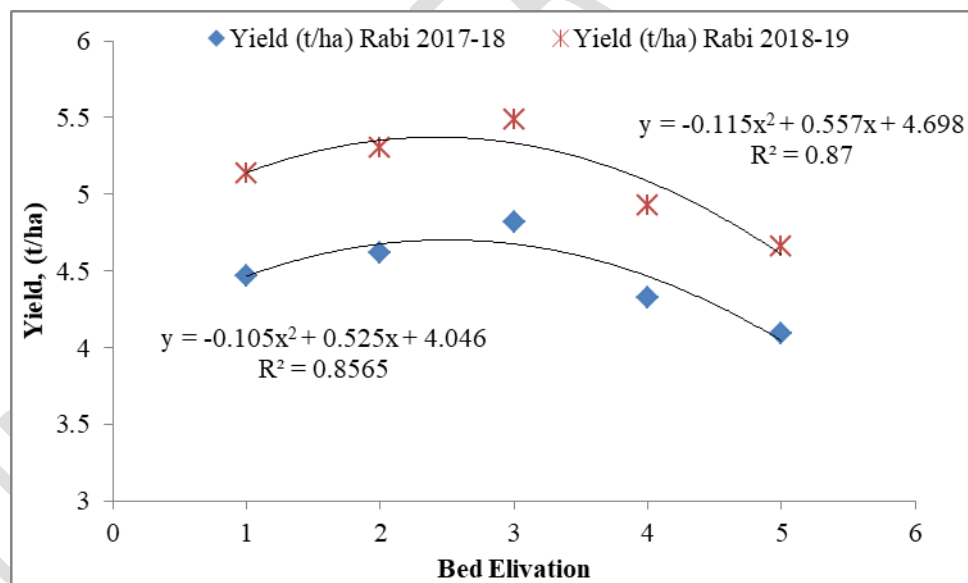

Fig. 8. Yield variation of recommended irrigation depth w.r.t. bed elevation

For sprinkler irrigation, the developed irrigation water application prescriptions (water depth/irrigation) include 400 mm ID for bed of 0 mm elevation, 476 mm ID for bed of 20 cm elevation and 552 mm ID for 30 mm bed elevation to sustain the wheat crop yield under soil moisture variability in Vertisols. Developed sprinkler irrigation application prescriptions (irrigation schedule) for wheat crop in Vertisols are given in Table 4.

Table 4. Sprinkler irrigation water application prescriptions for wheat crop in Vertisols, (ID-recommended irrigation depth)

Water Requirement of Wheat of 140 days = 345 mm								
Sprinkler Irrigation Efficiency = 85% No. of Irrigation: 5								
FC= 32% dwb PWP=18% dwb AW=14% dwb MAD=50%								
Applied water depth/irrigation = 80 mm at recommended irrigation depth								
Physiological Stages	Irrigation Water Prescriptions (Depth in mm) at ID- 1 RID							
Bed elevation (cm)	0	5	10	15	20	30	40	50
GS- DAS 15	80.0	80.8	82.6	88.5	91.8	106.5	125.8	150.3
T S- DAS 35	80.0	81.1	86.4	93.0	97.1	113.8	133.1	157.0
BS- DAS 58	80.0	81.1	86.5	93.4	97.4	113.7	133.2	156.9
EHBS - DAS 80	80.0	82.0	83.9	88.7	90.9	99.7	109.8	121.8
MGS - DAS 105	80.0	81.2	86.4	95.6	99.3	118.6	142.4	171.5
Total	400	406	425	459	476	552	644	757

CONCLUSIONS

Field studies on water saving and water productivity in different irrigation systems at CIAE, Bhopal revealed that conventional sprinkler irrigation and real time moisture sensor-based sprinkler irrigation resulted in average water saving of 25.45 and 53.94%, respectively with corresponding yield increase of 9.30 and 15.27 % as compared to gravity (flood) irrigation. The average soil moisture values varied significantly for the bed elevation (10 cm or more) as compared to control (bed with normal field level) treatment for different crop physiological stages under sprinkler irrigation in Vertisols for recommended irrigation water depth. Under recommended irrigation depth application through sprinkler, the wheat crop yield increased for elevation variations up to 10 cm bed elevation and more than 15 cm bed elevation variation, grain yield reduced significantly at 5% significance level. For sprinkler irrigation, the developed irrigation water application prescriptions (water depth/irrigation) include 400 mm ID for bed of 0 cm elevation, 476 mm ID for bed of 20 cm elevation and 552 mm ID for 30 cm bed elevation to sustain the wheat crop yield under soil moisture variability in Vertisols. Soil moisture based real time sprinkler irrigation scheduling resulted in significant water saving and higher water productivity in comparison to flood and sprinkler irrigation scheduling. Developed sprinkler irrigation water application prescriptions to address spatial soil moisture variability may be used by the beneficiary for achieving precision irrigation goal.

REFERENCES

- [1] Anonymous. Annual Report. Department of Agriculture and Cooperation, Ministry of Agriculture, Government of Madhya Pradesh, 2020.
- [2] Bassoi L H, Hopmans JW, Jorge L A D C. and Alencar C M D. Grapevine root distribution in drip and microsprinkler irrigation. *Scientia Agricola*. 2003; 60: 377-387.
- [3] Das T K, Bhattacharya R, Sudhishri S, Sharma A R, Saharawat Y S, Bandyopadhyay K K, and Jat M L. Conservation agriculture in an irrigated cotton-wheat system of the western Indo-Gangetic Plains: Crop and water productivity and economic profitability. *Field Crops Research*. 2014; 158: 24-33.

[4] Du, T., Kang, S., Zhang, J., & Davies, W. J. Deficit irrigation and sustainable water-resource strategies in agriculture for China's food security. *J. Exp. Botany*, 2015; 66(8), 2253-2269. <https://doi.org/10.1093/jxb/erv034>.

[5] El-Shafei A A and Mattar M A. Irrigation scheduling and production of wheat with different water quantities in surface and drip irrigation: Field experiments and modelling using CROPWAT and SALTMED. *Agronomy*. 2022; 12(7): p.1488.

[6] Geerts, S., & Raes, D. Deficit irrigation as an on-farm strategy to maximize crop water productivity in dry areas. *Agric. Water Mgmt.*, 2009; 96 (9), 1275-1284. <https://doi.org/10.1016/j.agwat.2009.04.009>.

[7] Issaka, Z.; Li, H.; Yue, J.; Tang, P.; Darko, R.O. Water-smart sprinkler irrigation, prerequisite to climate change adaptation: A review. *J. Water Clim. Chang.* 2018, 9, 383–398.

[8] Jiang, X.; Hua, M.; Yang, X.; Hu, N.; Qiu, R.; Yang, S. Impacts of mist spray on rice field micrometeorology and rice yield under heat stress condition. *Sci. Rep.* 2020, 10, 1579.

[9] Krishnamurthi, V. V., P. Manickasundaram, K. Vaiyapuri and P. Gnanamurthy . Microsprinkler: A Boon for Groundnut Crop, *Madras Agric. J.*, 2003.90 (1-3): 57- 59.

[10] Kumar D S and Palanisami K. Impact of drip irrigation on farming system: Evidence from Southern India. *Agricultural Economics Research Review*. 2010; 23:265–272.

[11] Liu, C., Jingjie, Y., & Kendy, E. Groundwater exploitation and its impact on the environment in the North China Plain. *Water Intl.*, 2001; 26(2), 265-272. <https://doi.org/10.1080/02508060108686913>.

[12] Pramanik S, Lai S, Ray R and PatraSK. Effect of drip fertigation on yield, water use efficiency and nutrients availability in Banana in West Bengal, India. *Communications in Soil Science and Plant Analysis*. 2016; 47(13–14):1691–1700. <https://doi.org/10.1080/00103624.2016.1206560>

[13] Rajanna G A, Dhindwal A S and Nanwal R K. Irrigation scheduling and crop establishment techniques in cluster bean-wheat sequence under semi-arid conditions of India- A review. *Ann. Agric. Res. New Series*. 2017; 37 (4): 335-346.

[14] Scanlon, B. R., Faunt, C. C., Longuevergne, L., Reedy, R. C., Alley, W. M., McGuire, V. L., & McMahon, P. B. Groundwater depletion and sustainability of irrigation in the U.S. High Plains and Central Valley. *Proc. Natl. Acad. Sci.*, 2012; 109(24), 9320-9325. <https://doi.org/10.1073/pnas.1200311109>.

[15] Shah T. Past, present and the future of canal irrigation in India. *India Infrastructure Report* 2011;69–89. www.rimisp.org/wp-content/uploads/2010/05/Paper_Tushaar_Shah.pdf.

[16] Sharma V, Singh PK, Bhakar S R, Yadav K K and Lakhawat S. Integration of soil moisture sensor based automated drip irrigation system for Okra crop. *International Journal of Pure & Applied Bioscience*. 2019;7(4):277–282. <https://doi.org/10.18782/2320-7051.7642>.

[17] Tari, A. F. The effects of different deficit irrigation strategies on yield, quality, and water-use efficiencies of wheat under semi-arid conditions. *Agric. Water Mgmt.*, 2016; 167, 1-10. <https://doi.org/10.1016/j.agwat.2015.12.023>.

[18] USDA. World Agricultural Production, United States. Department of Agriculture Foreign Agricultural Service Circular Series WAP 2020;9-20 September.

[19] Uygan, D.; Cetin, O.; Alveroglu, V.; Sofuoglu, A. Improvement of water saving and economic productivity based on quotation with sugar content of sugar beet using linear move sprinkler irrigation. *Agric. Water Manag.* 2021, 255, 106989.

[20] Wani S P, Rockstorm J and Oweis T. Rainfed agriculture: unlocking the potential. Wallingford, United Kingdom: 2009; CAB International 10.1079/9781845933890.0000.

[21] Zhang, Y., Kendy, E., Qiang, Y., Changming, L., Yanjun, S., & Hongyong, S. Effect of soil water deficit on evapotranspiration, crop yield, and water use efficiency in the North China Plain. *Agric. Water Mgmt.*, 2004; 64(2),107-122.[https://doi.org/10.1016/S0378-3774\(03\)00201-4](https://doi.org/10.1016/S0378-3774(03)00201-4).

UNDER PEER REVIEW